

Pharmaceutical X-ray Inspection System

KXE7510DGEKE



World-leading quality assurance

Opaque aluminum foil packaging materials are increasingly being used to maintain the quality of pharmaceutical products.

This makes it difficult to detect, whether by visual or camera inspection, product defects such as missing or chipped tablets and products caught in sealed parts.

Anritsu developed an x-ray inspection system designed specifically for pharmaceutical products. Its unique x-ray control technology enables pharmaceutical manufacturers to inspect transdermal patches caught in sealed areas and broken or missing pieces of orally-disintegrating tablets that were previously undetectable.





High sensitivity and high stability

The Anritsu Pharmaceutical X-ray Inspection System is equipped with a new X-ray unit most suitable for the inspection of thin products, which easily transmit x-rays. With significantly improved X-ray image quality and reduced variation in quality, which occurs in visual and tactile inspections, the system contributes to quality stabilization.

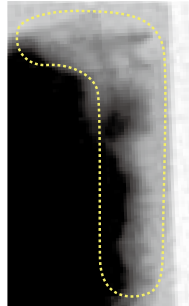

Conventional models



New model

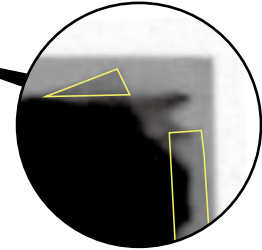

Our unique technology minimizes x-ray leakage so that a product with a height of 10mm or less can be conveyed without touching the leakage prevention curtain, which reduces the problem with false rejects caused by product jam or the disturbance of product orientation during conveyance. It also ensures that defective products are properly rejected at the correct timing.

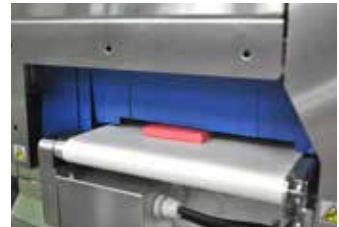

The system performs a variety of product integrity checks

The Anritsu Pharmaceutical X-ray Inspection System provides not only contaminant detection but also product verification simultaneously. Products in various types of retail packaging can be inspected for shape, count, and package check.

● Shape Inspection / Missing Product Detection

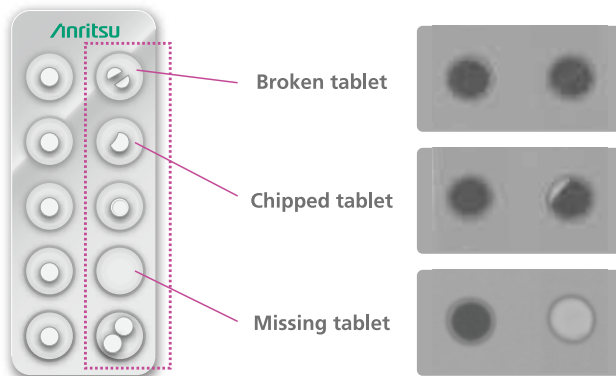

● Package Check

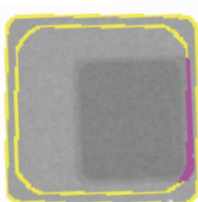

Transdermal patches



Facial treatment mask



Liniments



Setting the system with ease

Anyone can easily set the system to achieve high sensitivity.

Product Registration Navigation simplifies parameter setting procedures with step-by-step illustrated instructions. No fine adjustment is required, making it easier for anyone to set the system with the optimum use.

A simple product setup minimizes the time needed to register a new product, reducing the operator's workload.

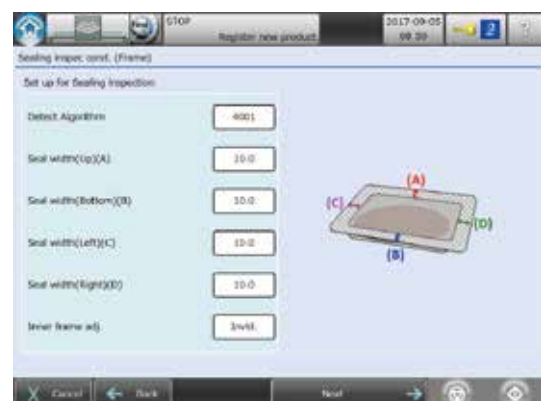

Supporting FDA 21 CFR Part 11

The KXE7510DGEKE model corresponds FDA 21 CFR Part 11 regulation with Eligibility authentication, Audit trail, Data encryption and decryption which all deliver a piece of mind to processors in the pharmaceutical industries.

Eligibility authentication (User management)

Access level can be individually set for each user to prevent unauthorized operations and potential operator mistakes.



Audit trail

The history of operations and actions related to production, results of operation check are internally recorded. The data can be used to monitor fraudulent activity and analyze the cause of such activity.



Data encryption and decryption

Various data including statistical and parameter data from Audit trail can be easily transmitted.



No blind spot design prevents contamination.

The conveyor belts and rollers including the front cover and x-ray leakage prevention curtains can be easily removed or attached without tools for easy cleaning and maintenance.

The design with no blind spot prevents statistical discrepancies and contamination due to improper conveyance and products falling off the line.





Anritsu safety mechanism

Safety in design

Anritsu believes customer safety is of utmost importance. The Anritsu x-ray system incorporates seven safety design features to ensure safe operation.

Emergency stop switch

Cuts power to x-ray and drive circuits, stops the conveyor and x-ray radiation

X-ray ON/OFF key

Turning the key to OFF stops x-ray radiation completely

X-ray shield cover open/close sensor

Opening the cover stops x-ray radiation completely

X-ray shield cover

Opened/Closed using x-ray irradiation ON/OFF key. Opening the cover stops x-ray radiation due to the x-ray shield cover open/close sensor



X-ray irradiation display

The lamp is lit during x-ray radiation

Leakage prevention curtain

Prevents x-ray leakage

Hand insertion sensor

Interrupting the sensor for a certain period of time stops x-ray radiation

Safety management

X-ray Inspection System has been designed to fully satisfy the safe operation. However, to ensure even higher safety, use the safety procedures outlined below.

1 Periodic measurement and recording of x-ray leakage data

3 Additional safety measures

Covers may need to be mounted on upstream and downstream conveyors instead of the shield curtains, depending on the shape, weight, and package of products.

2 Management of operator working hours

4 No disassembly or modification

NEVER modify or disassemble the main unit, covers, x-ray leakage prevention curtains, safety covers, safety interlocks, etc., otherwise the x-ray leak-proof design may no longer be functional.

Safety of inspected products

It is your responsibility to check and ensure that you comply with all applicable laws and regulations of your country or region regarding the effect of x-ray exposure on pharmaceutical products. Anritsu conducted a research with the Nagoya City University about the effect of x-rays on the pharmaceutical quality of drug tablets and found that exposure to x-rays did not affect pharmaceutical quality of the drug content.

We exposed commercially available non-steroidal anti-inflammatory drugs (acetaminophen, loxoprofen and mefenamic acid) to x-rays of various doses from 0.34 mGy to 300 Gy, and evaluated the quality of the tablets using pharmaceutical tests. We found the samples exposed to x-rays exhibited almost the same profile in the tests as control samples (0 Gy). We also investigated the influences of heat and humidity on drug tablets after x-ray exposure, and confirmed that the combination of x-ray exposure with accelerated temperature and humidity tests (40°C, relative humidity 75%) also did not affect the pharmaceutical quality. For more details, refer to the full report at <http://informahealthcare.com/ddi>

Anritsu Industrial Solutions Co., Ltd. (former company name) and Drug Delivery and Nano Pharmaceutics, Graduate School of Pharmaceutical Sciences, Nagoya City University (Drug Development and Industrial Pharmacy, 2015; 41(6): 953-958).

External Dimensions

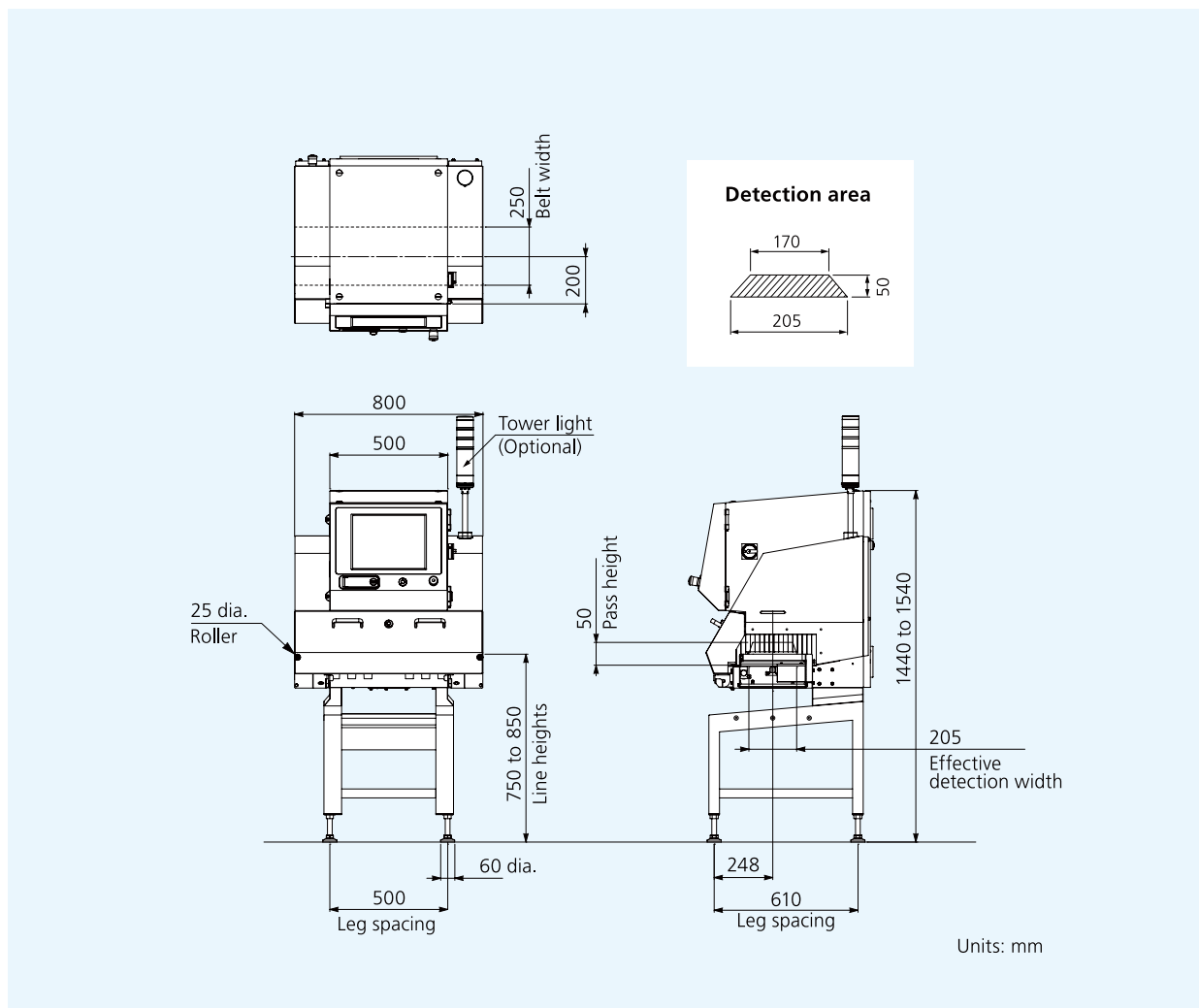

Specifications



Model	KXE7510DGEKE
Safety	X-ray leakage maximum 1.0 μ Sv/h or less, prevention of x-ray leakage by safety devices, lead-free shield curtains with a 10 mm clearance from the conveyor surface as standard
Display	15-inch color TFT LCD
Operation method	Touch panel (with touch buzzer)
Detection area ^{1,2}	Maximum width 205 mm, Maximum height 50 mm
Belt width	250 mm
Preset memory	200
Belt speed ³ / Maximum product weight ⁴	10 to 90 m/min, maximum 2 kg
Power requirements ⁵	100 Vac to 240 Vac, single phase, 50/60 Hz, 1.0 kVA or less
Mass ⁶	230 kg
Environmental conditions	Temperature: 0°C to 30°C, Relative humidity: 30% to 85%, non-condensing
Protection class	IP40
Exterior	Stainless steel (SUS304)

1 : The product size should fall below the detection area.

2 : The entrance and exit may require covers depending on the length of a product.

3 : Variable depending on Product No.

4 : Sum total of product weight on the conveyor.

5 : Allowable power fluctuation range is $\pm 10\%$.

6 : Mass without option.

Pharmaceutical Quality Assurance based on GMP

We offer a wide range of inspection solutions including weight check, contaminant and shape detection for the pharmaceutical manufacturing and packaging process.

Filling control/Weight check

Seal/Missing tablet check



Tablets



Capsules



Sachets / Sticks



Tube



Bottles / Cans

Tablets or Capsules
Checkweigher



Capsule
Checkweigher

Built-In Multi-Lane
Weighing System



Multi-Lane
Checkweigher



Aerosol Inhaler
Checkweigher



Small Bottle
Checkweigher



Pharmaceutical
X-ray Inspection
System



Missing blister pack check



Missing insert check (magnetic ink)



Missing pack check



Missing carton check



Supporting FDA 21 CFR Part 11,
SSV-h Series Checkweigher

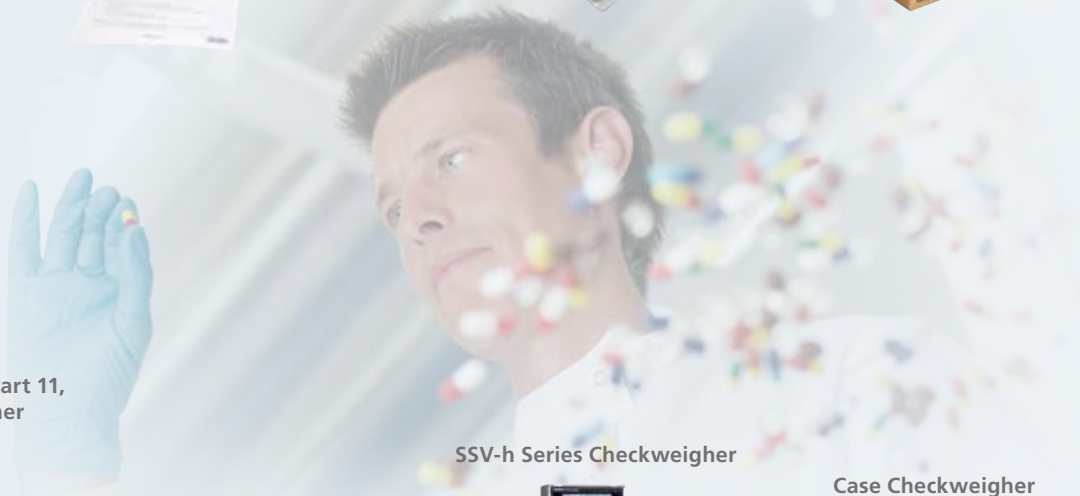

SSV-h Series Checkweigher



M Series Metal Detector



Case Checkweigher





ANRITSU INFIVIS CO., LTD.

International Sales Department

5-1-1 Onna, Atsugi-shi, Kanagawa-Prf., 243-0032, JAPAN
TEL: +81-46-296-6699 FAX: +81-46-296-6786
<https://www.anritsu.com/infivis>

Anritsu Industrial Solutions (Shanghai) Co., Ltd.

3F, No.55, Lane 1505, Zuchongzhi Road, Zhangjiang Hi-tech Park, Pudong New Area, Shanghai 201203, P.R.China
TEL: +86-21-5046-3066 FAX: +86-21-5046-3068

ANRITSU INFIVIS (THAILAND) CO., LTD.

700/678 Moo 1, Amata Nakorn Industrial Estate, T. Pangthong A. Pangthong Chonburi Province Thailand 20160
TEL: +66 38-447180 FAX: +66 38-447182

ANRITSU INFIVIS LTD.

200 Capability Green Luton LU1 3LU, United Kingdom
TEL: +44(0)1582-433227 FAX: +44(0)1582-731303

ANRITSU INFIVIS INC.

1001 Cambridge Drive, Elk Grove Village, IL 60007-2453, U.S.A.
TEL: +1-847-419-9729 FAX: +1-847-537-8266

© ANRITSU INFIVIS CO., LTD. 2017

ISO14001 CERTIFICATE No.JQA-EM0210
ISO 9001 CERTIFICATE No.JQA-0316

- Some products shown in this catalog may not be available in your country or region. Contact our sales representatives for details.
- To ensure proper operation, read the Operation Manual before using the machine.
- In addition to daily inspection, a full maintenance inspection should be completed annually.

Specifications are subject to change without notice.
No part of this catalog may be reproduced without our permission.

Printed on Recycled Paper