

High-Coherence Wavelength Swept Light Source

Kenichi Nakamura, Masaru Koshihara, Takanori Saitoh, Koji Kawakita

[Summary]

Optical technologies that have so far been restricted to the field of optical communications are now starting to be applied in new fields, especially medicine. Optical Frequency Domain Reflectometry (OFDR) offering fast and accurate target position measurements is one focus of attention. The Wavelength Swept Light Source (WSLS) is said to be one of the key devices of OFDR, whose sweep speed is being increased to support more accurate position tracking of dynamic targets. However, there have been little improvements in coherence length, which has a large impact on OFDR measurement distance and accuracy. Consequently, Anritsu has released high coherence (long coherence length) WSLS. This article evaluates measurable distance ranges used by OFDR with a focus on the coherence length of Anritsu WSLS. We examined the impact of wavelength sweep speed on coherence length. The results show this light source is suitable for OFDR measurements of distances on the order of 10 m to 100 m, demonstrating both high speed and high accuracy measurements over short to long distances. Additionally, since coherence length and wavelength sweep speed change in inverse proportion to each other, it is necessary to select wavelength sweep speed that is optimal for the measurement target.

1 Introduction

Optical Frequency Domain Reflectometry (OFDR), which is an optical measurement method using laser coherence, is starting to see applications in various fields. A main factor is the progress in improving the Wavelength Swept Light Source (WSLS)—the key device supporting faster and more accurate measurement of the target point. High-accuracy measurement OFDR systems for precision shapes, thin membranes, ultra-fine machining, are being commercialized and progress is especially remarkable in the field of ophthalmology diagnostics.

WSLS used in OFDR must be chosen appropriately to match the measurement target. Obtaining high position resolution requires a wide wavelength sweep range. For real-time measurement of a fast-moving target, a WSLS with a high wavelength sweep speed is required. The former is mainly limited by the gain band of the gain medium used in the main WSLS, and the latter depends on the mechanical response of the wavelength sweep mechanism.

Coherence length is an important characteristic of the WSLS for OFDR. The longer coherence length achieves longer measurable distance range and measurement of OFDR interference signal at high signal to noise ratio (SNR). Consequently, both the position resolution and accuracy can be improved. However, the SNR of the interfer-

ence signal continues to decrease as the measurement distance approaches the coherence length. As a result, it is important to select a WSLS with a sufficiently long coherence length for the measurement distance range. There is also a method to compensate for insufficient coherence length and extend the measurement distance by varying the position of the reference mirror of the interferometer. However, this interferometer is large and expensive because the reference mirror requires a movable mechanism, so there are concerns over the reduced vibration resistance of the interferometer.

There are many commercially available tunable light sources with claimed high coherence. These light sources have either a Littman or Littrow type resonator with a heavy solid optical system constructed to be rotated by a motor in order to vary the wavelength. The motor must rotate forwards and backwards to sweep the wavelength repeatedly, so the wavelength sweep frequency is very low at about 1 Hz.

On the other hand, a multi-mode-type, high-speed sweep light source with short coherence length is used in fields where real-time measurement is important, such as ophthalmology Optical Coherence Tomography (OCT). In this field, the measurement target is submillimeter-thick retina, and a coherence length on the order of 10 mm is sufficient.

Fabry-Perot type WSLs with high wavelength sweep speed and a relatively long coherence length have been fabricated¹⁾ using a Micro Electro Mechanical Systems (MEMS) technology-based tunable etalon filter. However, the gain band of the Vertical Cavity Surface Emitting Laser (VCSEL) used as the gain medium is as narrow as 50 nm, resulting in limit of the wavelength sweep range. In addition, an expensive optical amplifier must be added for applications requiring high optical output.

Consequently, we have developed and commercialized a high coherence WSLs with a kHz-order high wavelength sweep speed and a wide wavelength sweep range using a MEMS scanning mirror. This article demonstrates coherence length measurement with our WSLs and the applicable measurement distance.

2 Principle of High-Coherence Wavelength Swept Light Source

Figure 1 shows a diagram of the developed high coherence WSLs.

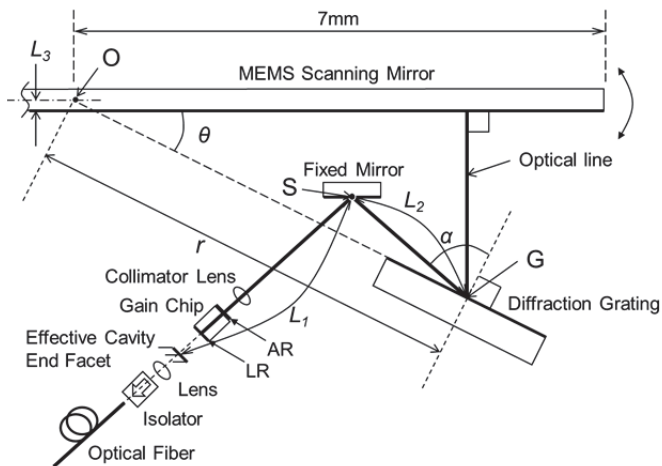

Figure 1 Diagram of High Coherence Wavelength Swept Light Source

To use a MEMS scanning mirror offering high-speed wavelength sweeping, the common Littman arrangement was upgraded to a unique optical arrangement^{2), 3)}. In this optical system, an external cavity is formed between the effective cavity end facet and reflective surface of the MEMS scanning mirror. One oscillation mode is selected among longitudinal modes determined by the cavity length, using the wavelength selectivity of the diffraction grating. Moreover, as shown in Figure 1, in this WSLs, the rotation center O of the MEMS scanning mirror is on a line extended

from the diffractive surface of the diffraction grating and the optical components are arranged to satisfy the following equation⁴⁾

$$L1 + L2 + L3 = r \cdot \sin \alpha \dots\dots\dots (1)$$

where, L1 is the effective optical distance from the effective cavity end facet considering the refractive index of the gain chip to the reflection point S on the fixed mirror, L2 is the optical length from point S to incident point G on the diffraction grating, L3 is the distance between the rotation center O and the reflective surface of the MEMS scanning mirror, r is the distance from point G to point O, and alpha is the incident angle of the optical beam from the fixed mirror to the diffraction grating.

When the equation (1) holds true, the following equation is satisfied

$$d\lambda_{mode}/d\theta = d\lambda_{filter}/d\theta \dots\dots\dots (2)$$

Where, lambda_mode is the longitudinal mode wavelength determined by the external cavity length, theta is the rotational angle of MEMS scanning mirror relative to the diffractive surface of the diffraction grating, and lambda_filter is the peak wavelength determined by the wavelength selectivity of the diffraction grating. Therefore, as shown in Figure 2, simply rotating the MEMS scanning mirror changes the wavelength of the single narrow-line longitudinal mode continuously without mode hopping.

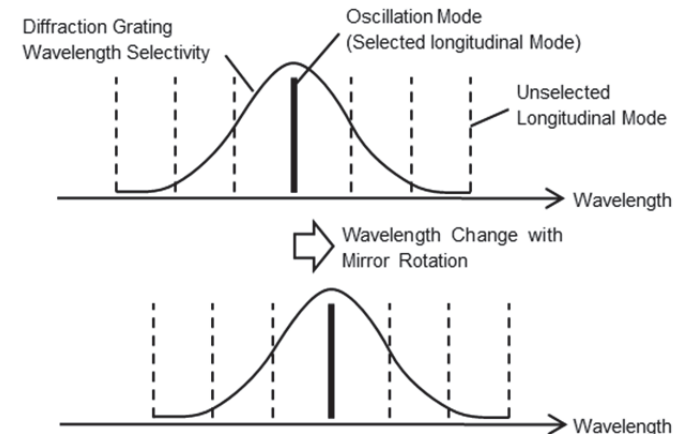

Figure 2 Changes in Diffraction Grating Wavelength Selectivity and Oscillation Mode due to Mirror Rotation

Wavelength sweeping while suppressing mode hopping requires sub-micron stability for the position of the rotation center of the rotation mechanism. This light source uses a MEMS scanning mirror to perform high-speed wavelength sweeping while keeping the rotation center position stable. The MEMS scanning mirror consists of the mirror part and

the pair of torsion bars on a straight line, which are fabricated as an integrated part by etching from one Si wafer. The simple and lightweight structure rotates the mirror part by twisting the torsion bars, providing fast rotational operation without rotation center displacement. Additionally, a large rotation angle, or wide wavelength sweep range, is realized by rotating the MEMS scanning mirror at the mechanical resonant frequency.

The rotation angle changes sinusoidally as shown in Figure 3. θ_0 is the angle θ without rotation operation of MEMS scanning mirror, f_{res} is the mechanical resonant frequency, and $\Delta\theta \times 2$ is the rotation angle range. Since the change in the oscillation mode wavelength versus the rotation angle is mostly linear at the rotation angle range used by this light source, the output wavelengths from this WLSL are also swept sinusoidally. For this reason, the maximum wavelength sweep speed is found close to the rotation angle θ_0 where the change rate of rotation angle $d\theta/dt$ is maximum, and this speed becomes larger in proportion to the rotation angle range, namely wavelength sweep range.

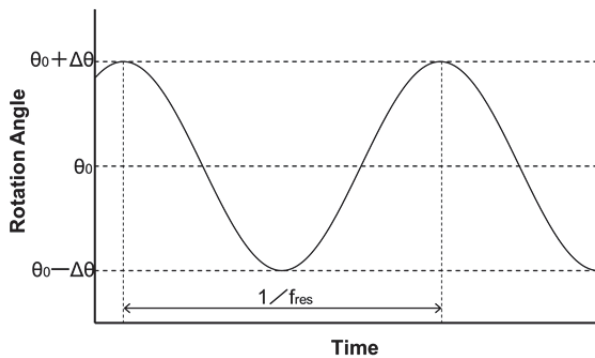

Figure 3 Change in MEMS Scanning Mirror Rotation Angle vs Time

3 Coherence Length Evaluation

3.1 Measurement Method

Figure 4 shows a system for evaluating the coherence length of the optical output from the WLSL.

The WLSL temperature is fixed at 25°C by the LD driver (ILX Lightwave, LDC-3724B) and a constant current is supplied to the gain chip. The sine-wave signal of 146.14-Hz equivalent to the MEMS scanning mirror resonant frequency is output by the Keysight 33210A signal generator (SG) for use as the MEMS scanning mirror drive signal after amplification.

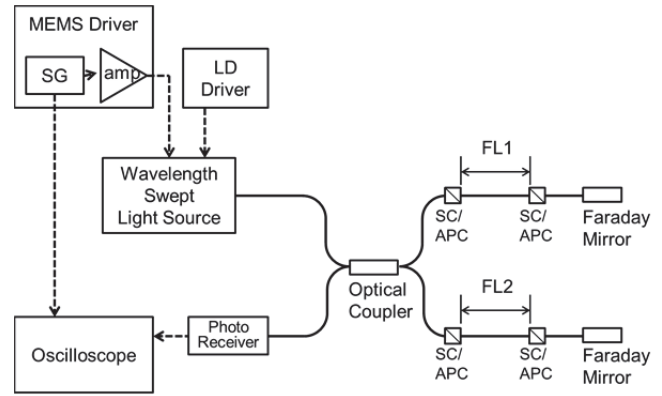

Figure 4 Coherence Length Evaluation System

The optical output from the WLSL passes via a single-mode optical fiber and is split at 50:50 optical coupler. The split lights are passed to fibers FL1 and FL2 and reflected by the Faraday mirrors, respectively. These reflected signals pass through the fibers again and are coupled at the optical coupler to generate optical interference. This optical interference is opto-electronically converted by a photoreceiver (New Focus, Model 1611) and monitored at the oscilloscope (Keysight DSOX4154A) as an interference signal corresponding to the optical path length differences.

Here, the length of FL1 was fixed to 520 mm and length of FL2 was changed so that the difference in the fiber lengths ($|FL1 - FL2| \times 2$) varied between 0.2 m and 100 m to measure the interference signal corresponding to each difference in fiber length. The optical pass length difference $|FL1 - FL2| \times 2 \times 1.47$ considering the optical fiber group refractive index 1.47 was from 0.29 m to 147 m.

The signal spectrum intensities were measured using the oscilloscope Fast Fourier Transform (FFT) function. Based on the peak power of the spectrum obtained when the optical pass length difference was 0.29 m, the difference in the optical path lengths when the peak power was attenuated by 6 dB was defined as the coherence length L_{CH} . The measurement wavelength range was around the rotation angle θ_0 where the MEMS scanning mirror wavelength sweep speed becomes maximum. As the window function for FFT, Hamming window was used.

Next, we examined how the wavelength sweep speed affects coherence length. As described in section 2, the maximum wavelength sweep speed is proportional to the wavelength sweep range. Then, we changed the wavelength sweep range to 25, 50, and 75 nm and measured the coherence length when the wavelength sweep speed was doubled and tripled.

The wavelength sweep speed decreases further from the rotation center angle, that is rotation angle θ_0 . Then, we performed evaluation of coherence lengths around wavelengths at a timing shifted by 1/12 and 1/6 cycle from the rotation angle θ_0 . Since the MEMS scanning mirror angle changes sinusoidally as shown in Figure 3, the ratios of the sweep speed at a timing shifted by 1/12 and 1/6 cycle to those at the rotation angle θ_0 are given as below:

$$1/12\text{-cycle shifted time: } \cos(2\pi/12)/\cos(0) = 0.87 \dots\dots(3)$$

$$1/6\text{-cycle shifted time: } \cos(2\pi/6)/\cos(0) = 0.5 \dots\dots\dots(4)$$

Since the rotation angle and the light source oscillation mode wavelength have a broadly linear relationship, the wavelength sweep speeds at each time were also $\times 0.87$ and $\times 0.5$.

3.2 Measurement Results and Considerations

Figure 5 shows an example of the interference signal FFT spectrum in the case of using a WSLs with wavelength sweep frequency of 146.14 Hz and wavelength sweep range of 50 nm, and interferometer with optical path length difference of 19.2 m. The FFT spectrum was measured around the rotation angle θ_0 where the wavelength sweep speed became maximum. Then, we examined how peak power of the FFT spectrum changed with the optical path length difference based on the peak power for the optical path length difference of 0.29 m.

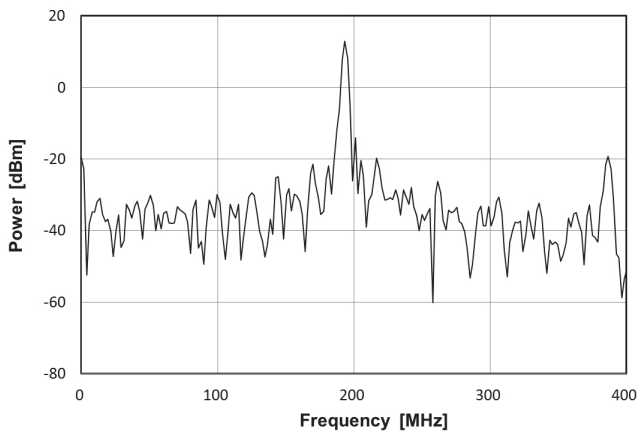
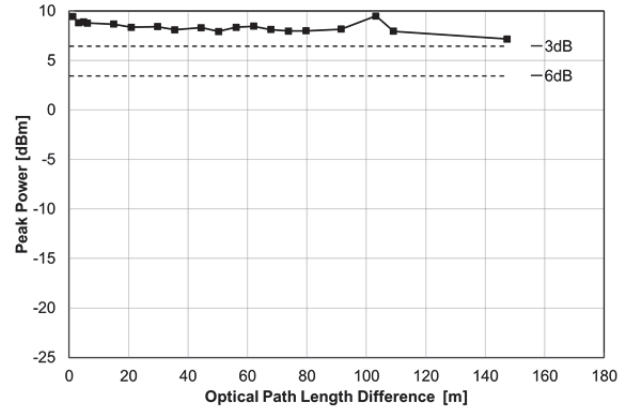
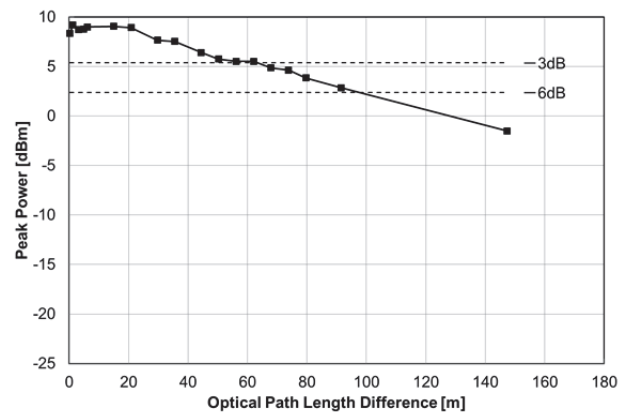

Figure 5 Example of Interference Signal FFT Spectrum

Figures 6 (a), (b), and (c) show the spectrum peak power measurement results for the optical path length differences of 25, 50, and 75 nm, respectively. The dashed lines in the figures indicate the -3 and -6 dB levels for the peak power at the optical path length difference of 0.29 m.



(a) 25 nm Wavelength Sweep Range



(b) 50 nm Wavelength Sweep Range

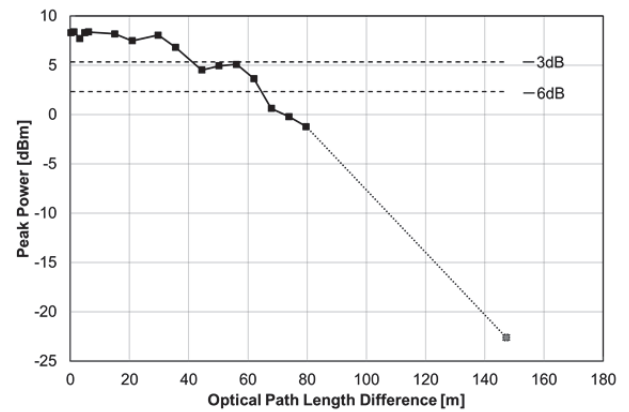

(c) 75 nm Wavelength Sweep Range

Figure 6 Spectrum Peak Power vs Optical Path Length Difference

From these results, the peak power for the wavelength sweep range of 25 nm attenuates only up to 3 dB even when the optical path length difference is 147 m. The coherence lengths L_{CH} for the wavelength sweep range of 50 and 75 nm are 100 m and 64.7 m, respectively. Based on these results, our WSLs is suitable for OFDR measurements from

10 m to about 100 m, offering both high speed and high accuracy measurement over short to long distances.

Next, Figures 7 (a) and (b) show the measurement results at wavelength sweep range of 50 nm and at a timing shifted by 1/12 and 1/6 cycle from the rotation angle θ_0 , respectively. At a timing shifted by 1/6 cycle, as shown in Eq. (3), the wavelength sweep speed is $\times 0.5$ and the peak power attenuates only up to -3 dB even when the optical path length difference is 147 m.

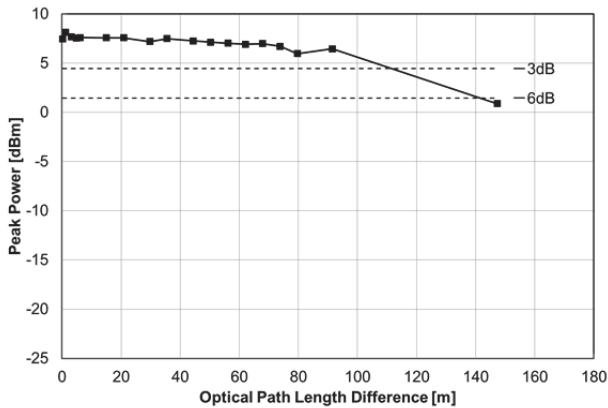

(a) 1/12 Cycle

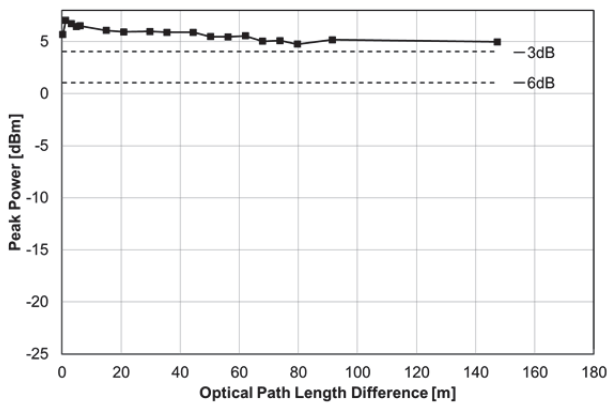

(b) 1/6 Cycle

Figure 7 Spectrum Peak Power vs Optical Path Length Difference

Comparing Figure 6 (a) and Figure 7 (b) with Figure 6 (b), even when changing the wavelength sweep range from 50 nm to 25 nm and halving the sweep speed, the peak power attenuation remains broadly the same when shifting the measured wavelength range by 1/6 cycle from the rotation angle θ_0 and halving the sweep speed (Eq. 4). This suggests that the coherence length is mainly dependent on the wavelength sweep speed.

Looking next at the relationship between coherence

length and wavelength sweep speed found from Figures 6 (c) and (b) and Figure 7 (a), we used the reciprocal of the relative wavelength sweep speed standardized at the wavelength sweep speed at the rotation angle θ_0 for wavelength sweep range of 50 nm. The reciprocals of the relative swept wavelength speeds 0.67, 1, and 1.15 in Figure 6 (c), and (b), and Figure 7 (a) were plotted against the coherence lengths 64.7, 100, and 144 m, respectively as shown in Figure 8. From this figure, at this measured wavelength sweep speed range, coherence length is roughly inversely proportional to wavelength sweep speed.

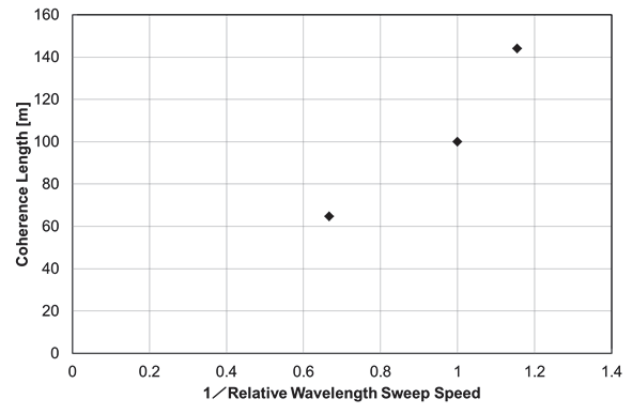

Figure 8 Relationship between Relative Wavelength Sweep Speed and Coherence Length

We believe this is due to the dependence of the line width on the wavelength sweep speed. The line width of the oscillation mode of the external cavity shown in Figure 1 becomes narrower as the number of interference times among lights reflected repeatedly at the end facet of the cavity increases. However, wavelength changes with time in the case of WSLs, so there is a limit to the interference times for lights at the same phase in the external cavity. Since the interference times decrease in inverse proportion to the sweep speed, the line width reduction is correspondingly limited. As a result, we believe the coherence length with an inverse proportional relationship to line width shortens as the wavelength sweep speed increases. Consequently, there is a tradeoff between wavelength sweep speed and coherence length, making it necessary to select a wavelength sweep speed that is optimal for the measurement target.

4 Conclusions

We evaluated the coherence length of our WSLs with a MEMS scanning mirror. We used a 1.55- μm band WSLs

with a wavelength sweep frequency of 146.14 Hz. The evaluation results showed the coherence lengths were 100 m and 64.7 m at wavelength sweep ranges of 50 and 75 nm, respectively, and exceeded 147 m at 25 nm. Our WSLS is suitable for OFDR measurements on the order of 10 m to 100 m, offering both high speed and high accuracy measurements from short to long distances without addition of a movable reference mirror mechanism.

In addition, the evaluation results of the relationship between coherence length and wavelength sweep speed demonstrated an approximate inverse proportional relationship. Due to the tradeoff between wavelength sweep speed and coherence length, it is important to select a sweep speed that is optimal for the measurement target.

References

- 1) N. Kanbara, S. Tezuka, and T. Watanabe, "MEMS VCSEL with concave mirror using the selective polishing method," in Proc. Optical MEMS Conf., 2006, pp.9-10
- 2) M. G. Littman and H. J. Metcalf, "Spectrally narrow pulsed dye laser without beam expander," Appl. Opt., vol.17, pp.2224-2227, Jul. 1978.
- 3) K. Nakamura, S. Morimoto, and T. Nakayama, "Single-Mode and Mode-Hop-Free Wavelength Sweep Light Source with Range of Over 160 nm and High Swept Frequency," IEEE Photonics Technology Letters, Vol. 22, No. 19, Oct. 2010.
- 4) T. Tanimoto, S. Mattori, H. Kameyama, F. Otagaki, and H. Otateme, "Wavelength tunable laser," Japanese Patent No. 3069643

Authors



Kenichi Nakamura
Business Originating Center



Masaru Koshihara
Business Originating Center



Takanori Saitoh
Business Originating Center



Koji Kawakita
Business Originating Center

Publicly available