

**MP2110A
BERTWave
Operation Manual**

27th Edition



**For safety and warning information, please read this manual before attempting to use the equipment.
Keep this manual with the equipment.**

ANRITSU CORPORATION

Safety Symbols

To prevent the risk of personal injury or loss related to equipment malfunction, ANRITSU CORPORATION uses the following safety symbols to indicate safety-related information. Ensure that you clearly understand the meanings of the symbols BEFORE using the equipment. Some or all of the following symbols may be used on all Anritsu equipment. In addition, there may be other labels attached to products that are not shown in the diagrams in this manual.

Symbols used in manual

-  **DANGER** This indicates a very dangerous procedure that could result in serious injury or death if not performed properly.
-  **WARNING** This indicates a hazardous procedure that could result in serious injury or death if not performed properly.
-  **CAUTION** This indicates a hazardous procedure or danger that could result in minor to moderate injury, or loss related to equipment malfunction, if proper precautions are not taken.

Safety Symbols Used on Equipment and in Manual

The following safety symbols are used inside or on the equipment near operation locations to provide information about safety items and operation precautions. Ensure that you clearly understand the meanings of the symbols and take the necessary precautions BEFORE using the equipment.



This indicates a prohibited operation. The prohibited operation is indicated symbolically in or near the barred circle.



This indicates an obligatory safety precaution. The obligatory operation is indicated symbolically in or near the circle.



This indicates a warning or caution. The contents are indicated symbolically in or near the triangle.



This indicates a note. The contents are described in the box.



These indicate that the marked part should be recycled.

MP2110A
BERTWave
Operation Manual

13 January 2017 (First Edition)
16 August 2024 (27th Edition)

Copyright © 2017-2024, ANRITSU CORPORATION.

All rights reserved. No part of this manual may be reproduced without the prior written permission of the publisher.

The operational instructions of this manual may be changed without prior notice.

Printed in Japan

For Safety

WARNING



- ALWAYS refer to the operation manual when working near locations at which the alert mark shown on the left is attached. If the advice in the operation manual is not followed, there is a risk of personal injury or reduced equipment performance. The alert mark shown on the left may also be used with other marks and descriptions to indicate other dangers.

- Overvoltage Category

This equipment complies with overvoltage category II defined in IEC 61010. DO NOT connect this equipment to the power supply of overvoltage category III or IV.

Electric Shock

- To ensure that the equipment is grounded, always use the supplied 3-pin power cord, and insert the plug into an outlet with a ground terminal. If power is supplied without grounding the equipment, there is a risk of receiving a severe or fatal electric shock or causing damage to the internal components.

Repair



- Only qualified service personnel with a knowledge of electrical fire and shock hazards should service this equipment. This equipment cannot be repaired by the operator. DO NOT attempt to remove the equipment covers or unit covers or to disassemble internal components. There are high-voltage parts in this equipment presenting a risk of severe injury or fatal electric shock to untrained personnel. In addition, there is a risk of damage to precision components.

Calibration



- The performance-guarantee seal verifies the integrity of the equipment. To ensure the continued integrity of the equipment, only Anritsu service personnel, or service personnel of an Anritsu sales representative, should break this seal to repair or calibrate the equipment. Be careful not to break the seal by opening the equipment or unit covers. If the performance-guarantee seal is broken by you or a third party, the performance of the equipment cannot be guaranteed.

For Safety

WARNING

Falling Over

- This equipment should always be positioned in the correct manner. If the cabinet is turned on its side, etc., it will be unstable and may be damaged if it falls over as a result of receiving a slight mechanical shock.

Always set up the equipment in a position where the power switch can be reached without difficulty.

For Safety

CAUTION

Cleaning

- Always remove the main power cable from the power outlet before cleaning dust around the power supply and fan.
 - Clean the power inlet regularly. If dust accumulates around the power pins, there is a risk of fire.
 - Keep the cooling fan clean so that the ventilation holes are not obstructed. If the ventilation is obstructed, the cabinet may overheat and catch fire.

Check Terminal



- Never input a signal of more than the indicated value between the measured terminal and ground. Input of an excessive signal may damage the equipment.

Static Sensitive



- Always take the following anti-static measures to prevent the internal circuit from being damaged when using a connector indicated by the symbol shown on the left.
 - Wear a wrist strap connected to the ground terminal of this equipment.
 - Connect the ground wires of this equipment, external measuring instruments and DUT before connecting a coaxial cable.
 - Eliminate static electricity charged between the cores and outer conductors of an external device and the coaxial cable, before connecting this equipment and the external device.

Replacing Memory Back-up Battery

This equipment uses a Poly-carbon monofluoride lithium battery to backup the memory. This battery must be replaced by service personnel when it has reached the end of its useful life; contact the Anritsu sales section or your nearest representative.

Note: The battery used in this equipment has a maximum useful life of 2 years. It should be replaced before this period has elapsed.

The life of the battery will vary depending on the length of equipment usage and the operating environment.

The following conditions may be observed if the battery has expired.

- When power to the equipment is supplied, the time display may no longer match the actual time.

For Safety

CAUTION

External Storage Media

This equipment uses USB flash drive as external storage media for storing data and programs.

If this media is mishandled or becomes faulty, important data may be lost. It is recommended to periodically back up all important data and programs to protect them from being lost accidentally.

Anritsu will not be held responsible for lost data.

Pay careful attention to the following points.

- Never remove the USB flash drive from the equipment while it is being accessed.
 - The USB flash drive may be damaged by static electric charges.
 - Anritsu has thoroughly tested all external storage media such as USB flash drive, Hard disk drive and DVD drive. Users should note that external storage media may not have been tested by Anritsu, thus Anritsu cannot guarantee the performance or suitability of such media.
-

For Safety

CAUTION

SSD

The equipment is equipped with a SSD (Solid State Drive) from which, as with any flash memory, data may be lost because of limitation of writing times. It is recommended to periodically back up all important data and programs to protect them from being lost accidentally. Anritsu will not be held responsible for lost data.

To reduce the possibility of data loss, particular attention should be given to the following points.

- The equipment should only be used within the recommend temperature range, and should not be used in locations where the temperature may fluctuate suddenly.
- Always follow the guidelines to ensure that the equipment is set up in the specified manner.
- Always ensure that the fans at the rear and side of the equipment are not blocked or obstructed in any way.
- Exercise care not to bang or shake the equipment whilst the power is on.
- Never disconnect the mains power at the plug or cut the power at the breaker with the equipment turned on.

Lifetime of Parts

The life span of certain parts used in this equipment is determined by the operating time or the power-on time. Due consideration should be given to the life spans of these parts when performing continuous operation over an extended period. The safety of the equipment cannot be guaranteed if component parts are used beyond their life spans. These parts must be replaced at the customer's expense even if within the guaranteed period described in Warranty at the beginning of this manual.

For details on life-span, refer to the corresponding section in this manual.

Coaxial switch: One million times (Switching scope optical input connector)

Coaxial switch: Five million times (Switching BERT clock output channel)

For Safety

CAUTION

Use in a Residential Environment

This equipment is designed for an industrial environment. In a residential environment, this equipment may cause radio interference in which case the user may be required to take adequate measures.

Use in Corrosive Atmospheres

Exposure to corrosive gases such as hydrogen sulfide, sulfurous acid, and hydrogen chloride will cause faults and failures. Note that some organic solvents release corrosive gases.

Equipment Certificate

ANRITSU CORPORATION certifies that this equipment was tested before shipment using calibrated measuring instruments with direct traceability to public testing organizations recognized by national research laboratories, including the National Institute of Advanced Industrial Science and Technology, and the National Institute of Information and Communications Technology, and was found to meet the published specifications.

Anritsu Warranty

ANRITSU CORPORATION will repair this equipment free-of-charge if a malfunction occurs within one year after shipment due to a manufacturing fault, and software bug fixes will be performed in accordance with the separate Software End-User License Agreement, provide, however, that ANRITSU CORPORATION will deem this warranty void when:

- The fault is outside the scope of the warranty conditions separately described in the operation manual.
- The fault is due to mishandling, misuse, or unauthorized modification or repair of the equipment by the customer.
- The fault is due to severe usage clearly exceeding normal usage.
- The fault is due to improper or insufficient maintenance by the customer.
- The fault is due to natural disaster, including fire, wind or flood, earthquake, lightning strike, or volcanic ash, etc.
- The fault is due to damage caused by acts of destruction, including civil disturbance, riot, or war, etc.
- The fault is due to explosion, accident, or breakdown of any other machinery, facility, or plant, etc.
- The fault is due to use of non-specified peripheral or applied equipment or parts, or consumables, etc.
- The fault is due to use of a non-specified power supply or in a non-specified installation location.
- The fault is due to use in unusual environments^(Note).
- The fault is due to activities or ingress of living organisms, such as insects, spiders, fungus, pollen, or seeds.

In addition, this warranty is valid only for the original equipment purchaser. It is not transferable if the equipment is resold.

ANRITSU CORPORATION shall assume no liability for damage or financial loss of the customer due to the use of or a failure to use this equipment, unless the damage or loss is caused due to ANRITSU CORPORATION's intentional or gross negligence.

Note:

For the purpose of this Warranty, "unusual environments" means use:

- In places of direct sunlight
- In dusty places
- Outdoors
- In liquids, such as water, oil, or organic solvents, and medical fluids, or places where these liquids may adhere
- In salty air or in place chemically active gases (sulfur dioxide, hydrogen sulfide, chlorine, ammonia, nitrogen dioxide, or hydrogen chloride etc.) are present
- In places where high-intensity static electric charges or electromagnetic fields are present
- In places where abnormal power voltages (high or low) or instantaneous power failures occur
- In places where condensation occurs
- In the presence of lubricating oil mists
- In places at an altitude of more than 2,000 m
- In the presence of frequent vibration or mechanical shock, such as in cars, ships, or airplanes

ANRITSU CORPORATION Contact

In the event of this equipment malfunctions, please contact an Anritsu Service and Sales office. Contact information can be found on the Anritsu website.

Notes On Export Management

- We assume no responsibility if this product and the attached power cord are re-exported and used without our approval since they may not comply with the safety standards, etc., of specific countries.
- This product and its manuals may require an Export License/Approval by the Government of the product's country of origin for re-export from your country.

Before re-exporting the product or manuals, please contact us to confirm whether they are export-controlled items or not.

For more details, visit

<https://www.anritsu.com/support/export-procedures>.

When you dispose of the products or manuals subject to export control, they must be physically destroyed or shredded so as not to be unlawfully used for military purpose.

Crossed-out Wheeled Bin Symbol

Equipment marked with the Crossed-out Wheeled Bin Symbol complies with council directive 2012/19/EU (the “WEEE Directive”) in European Union.



For Products placed on the EU market after August 13, 2005, please contact your local Anritsu representative at the end of the product's useful life to arrange disposal in accordance with your initial contract and the local law.

Software End-User License Agreement (EULA)

Please carefully read and accept this Software End-User License Agreement (hereafter this EULA) before using (includes executing, copying, installing, registering, etc.) this Software (includes programs, databases, scenarios, etc., used to operate, set, etc., Anritsu electronic equipment, etc.). By using this Software, you shall be deemed to have agreed to be bound by the terms of this EULA, and ANRITSU CORPORATION (hereafter Anritsu) hereby grants you the right to use this Software with the Anritsu specified equipment (hereafter Equipment) for the purposes set out in this EULA.

Article 1. Grant of License and Limitations

1. You may not sell, transfer, rent, lease, lend, disclose, sublicense, or otherwise distribute this Software to third parties, whether or not paid therefor.
2. You may make one copy of this Software for backup purposes only.
3. You are not permitted to reverse engineer, disassemble, decompile, modify or create derivative works of this Software.
4. This EULA allows you to install one copy of this Software on one piece of Equipment.

Article 2. Disclaimers

To the extent not prohibited by law, in no event shall Anritsu be liable for direct, or any incidental, special, indirect or consequential damages whatsoever, including, without limitation, damages for loss of profits, loss of data, business interruption or any other commercial damages or losses, and damages claimed by third parties, arising out of or related to your use or inability to use this Software, unless the damages are caused due to Anritsu's intentional or gross negligence.

Article 3. Limitation of Liability

1. If a fault (bug) is discovered in this Software, making this Software unable to operate as described in the operation manual or specifications even though you have used this Software as described in the manual, Anritsu shall at its own discretion, fix the bug, or replace the software, or suggest a workaround, free-of-charge, provided, however, that the faults caused by the

following items and any of your lost or damaged data whatsoever shall be excluded from repair and the warranty.

- i) If this Software is deemed to be used for purposes not described in the operation manual or specifications.
 - ii) If this Software has been used in conjunction with other non-Anritsu-approved software.
 - iii) If this Software or the Equipment has been modified, repaired, or otherwise altered without Anritsu's prior approval.
 - iv) For any other reasons out of Anritsu's direct control and responsibility, such as but not limited to, natural disasters, software virus infections, or any devices other than this Equipment, etc.
2. Expenses incurred for transport, hotel, daily allowance, etc., for on-site repairs or replacement by Anritsu engineers necessitated by the above faults shall be borne by you.
 3. The warranty period for faults listed in Section 1 of this Article shall be either 6 months from the date of purchase of this Software or 30 days after the date of repair or replacement, whichever is longer.

Article 4. Export Restrictions

You shall not use or otherwise export or re-export directly or indirectly this Software except as authorized by the laws and regulations of Japan and the United States, etc. In particular, this Software shall not be exported or re-exported (a) into any Japan or US embargoed countries or (b) to anyone restricted by the Japanese export control regulations, or the US Treasury Department's list of Specially Designated Nationals or the US Department of Commerce Denied Persons List or Entity List. In using this Software, you warrant that you are not located in any such embargoed countries or on any such lists. You also agree that you will not use or otherwise export or re-export this Software for any purposes prohibited by the Japanese and US laws and regulations, including, without limitation, the development, design and manufacture or production of missiles or nuclear, chemical or biological weapons of mass destruction, and conventional weapons.

Article 5. Change of Terms

Anritsu may change without your approval the terms of this EULA if the changes are for the benefit of general customers, or are reasonable in light of the purpose of this EULA and circumstances of the changes. At the time of change, Anritsu will inform you of those changes and its effective date, as a general rule 45 days, in advance on its website, or in writing or by e-mail.

Article 6. Termination

1. Anritsu may terminate this EULA immediately if you violate any conditions described herein. This EULA shall also be terminated immediately by Anritsu if there is any good reason that it is deemed difficult to continue this EULA, such as your violation of Anritsu copyrights, patents, etc. or any laws and ordinances, or if it turns out that you belong to an antisocial organization

or has a socially inappropriate relationship with members of such organization.

2. You and Anritsu may terminate this EULA by a written notice to the other party 30 days in advance.

Article 7. Damages

If Anritsu suffers any damages or loss, financial or otherwise, due to your violation of the terms of this EULA, Anritsu shall have the right to seek proportional damages from you.

Article 8. Responsibility after Termination

Upon termination of this EULA in accordance with Article 6, you shall cease all uses of this Software immediately and shall as directed by Anritsu either destroy or return this Software and any backup copies, full or partial, to Anritsu.

Article 9. Negotiation for Dispute Resolution

If matters of interpretational dispute or items not covered under this EULA arise, they shall be resolved by negotiations in good faith between you and Anritsu.

Article 10. Governing Law and Court of Jurisdiction

This EULA shall be governed by and interpreted in accordance with the laws of Japan without regard to the principles of the conflict of laws thereof, and any disputes arising from or in relation to this EULA that cannot be resolved by negotiation described in Article 9 shall be subject to and be settled by the exclusive agreed jurisdiction of the Tokyo District Court of Japan.

Revision History:

- February 29th, 2020
- December 17th, 2021
- March 11th, 2024

Cautions Against Computer Virus Infection

- Copying files and data
Only files that have been provided directly from Anritsu or generated using Anritsu equipment should be copied to the instrument.
All other required files should be transferred by means of USB flash drive or CompactFlash media after undergoing a thorough virus check.
- Adding software
Do not download or install software that has not been specifically recommended or licensed by Anritsu.
- Network connections
Ensure that the network has sufficient anti-virus security protection in place.
- Protection against malware (malicious software such as viruses).
This equipment runs on Windows Operating System.
To connect this equipment to network, the following is advised.
 - Activate Firewall.
 - Install important updates of Windows.
 - Use antivirus software.

CE Conformity Marking

Anritsu affixes the CE conformity marking on the following product in accordance with the Decision 768/2008/EC to indicate that it conforms to the EMC, LVD, and RoHS directive of the European Union (EU).

CE marking



1. Product Model

Model: MP2110A BERTWave

2. Applied Directive

EMC: Directive 2014/30/EU

LVD: Directive 2014/35/EU

RoHS: Directive 2011/65/EU, (EU) 2015/863

3. Applied Standards

- EMC:Emission: EN 61326-1: 2013 (Class A)
Immunity: EN 61326-1: 2013 (Table 2)

	Performance Criteria*
IEC 61000-4-2 (ESD)	B
IEC 61000-4-3 (EMF)	A
IEC 61000-4-4 (Burst)	B
IEC 61000-4-5 (Surge)	B
IEC 61000-4-6 (CRF)	A
IEC 61000-4-11 (V dip/short)	B, C

*: Performance Criteria

A: The equipment shall continue to operate as intended during and after the test. No degradation of performance or loss of function is allowed below a performance level specified by the manufacturer, when the equipment is used as intended. The performance level may be replaced by a permissible loss of performance. If the minimum performance level or the permissible performance loss is not specified by the manufacturer, either of these may be derived from the product description and documentation and what the user may reasonably expect from the equipment if used as intended.

- B: The equipment shall continue to operate as intended after the test. No degradation of performance or loss of function is allowed below a performance level specified by the manufacturer, when the equipment is used as intended. The performance level may be replaced by a permissible loss of performance. During the test, degradation of performance is however allowed. No change of actual operating state or stored data is allowed. If the minimum performance level or the permissible performance loss is not specified by the manufacturer, either of these may be derived from the product description and documentation and what the user may reasonably expect from the equipment if used as intended.
- C: Temporary loss of function is allowed, provided the function is self-recoverable or can be restored by the operation of the controls.

Harmonic current emissions:

EN 61000-3-2: 2014 (Class A equipment)

: No limits apply for this equipment with an active input power under 75 W.

- LVD: EN 61010-1: 2010 +A1:2019 (Pollution Degree 2)
- RoHS: EN IEC 63000:2018 (Category 9)

If the third digit of the serial number is "7", the product complies with Directive 2011/65/EU as amended by (EU) 2015/863.

(Pb,Cd,Cr6+,Hg,PBB,PBDE,DEHP,BBP,DBP,DIBP)

If the third digit of the serial number is "6", the product complies with Directive 2011/65/EU.

(Pb,Cd,Cr6+,Hg,PBB,PBDE)

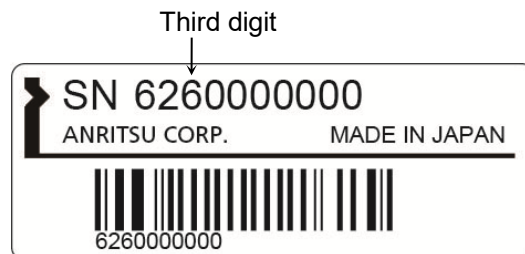

Serial number example

4. Contact

Name: Anritsu GmbH
 Address, city: Nemetschek Haus, Konrad-Zuse-Platz 1
 81829 München,
 Country: Germany

UKCA Marking

Anritsu affixes the UKCA marking on the following product in accordance with the guidance to indicate that it conforms to the EMC, LVD, and RoHS regulations in the United Kingdom.

UKCA marking



1. Product Model

Model: MP2110A BERTWave

2. Applied Regulations

EMC: S.I. 2016 No. 1091

LVD: S.I. 2016 No. 1101

RoHS: S.I. 2012 No. 3032

3. Applied Standards

- EMC: Emission: EN 61326-1: 2013 (Class A)
Immunity: EN 61326-1: 2013 (Table 2)
- LVD: EN 61010-1: 2010 +A1:2019 (Pollution Degree 2)
- RoHS: EN IEC 63000: 2018 (Category 9)

4. Contact

Name: ANRITSU EMEA Ltd.
Address, city: 200 Capability Green, Luton
Bedfordshire, LU1 3LU
Country: United Kingdom

RCM Conformity Marking

Anritsu affixes the RCM mark on the following product in accordance with the regulation to indicate that it conforms to the EMC framework of Australia/New Zealand.

RCM marking



1. Product Model

Model: MP2110A BERTWave

2. Applied Standards

EMC: Emission: EN 61326-1: 2013 (Class A equipment)

About Eco label



The label shown on the left is attached to Anritsu products meeting our environmental standards.

Details about this label and the environmental standards are available on the Anritsu website at <https://www.anritsu.com>

About This Manual

The manual set for the BERTWave Series consists of the following five operation manuals:

MP2110A BERTWave Operation Manual
(M-W3831AE) (This Manual)

This manual is intended for those who use the MP2110A BERTWave, and explains the installation procedure, handling precautions, connector connection procedures, panel operations, maintenance procedures, specifications and various functions.

MP2100B BERTWave Operation Manual
(M-W3772AE)

This manual is intended for those who use the MP2100B BERTWave, and explains the installation procedure, handling precautions, connector connection procedures, panel operations, maintenance procedures, specifications and various functions.

MX210001A Jitter Analysis Software
Operation Manual (M-W3569AE)

This manual explains the operation method and remote control commands for the MX210001A Jitter Analysis Software.

MX210002A Transmission Analysis Software
Operation Manual (M-W3571AE)

This manual explains the operation method and remote control commands for the MX210002A Transmission Analysis Software.

BERTWave series Remote Control
Operation Manual (M-W3773AE)

This manual explains the commands to control the BERTWave, status register structure, and sample programs.

This operation manual assumes the reader has the following basic knowledge:

- Optical communications, handling optical parts
- Bit error measurement method
- Oscilloscope operation
- Windows file operations and the Windows Control Panel

Manual Notation System

The MP2110A BERTWave is referred to as the MP2110A in this manual.

The user interface such as button and tab names are in bold.

Example: **PPG**, **System Menu**

The connector names on the panel are in **Arial – Bold**.

Example: **Data Out**, **Ch A In**

x in the option number represents 0, 1, or 3. The range of x depends on the option number. Refer to “Table A.1-5 Options” or the product brochure.

Example: **MP2110A-x11 represents MP2110A-011 or MP2110A-111.
MP2110A-311 does not exist.**

Table of Contents

For Safety	iii
About This Manual	I
Chapter 1 Outline	1-1
1.1 Introduction of BERTWave	1-2
1.2 Configuration	1-10
1.3 Features	1-17
1.4 Intended Use	1-18
1.5 Technical Terms	1-21
1.6 Abbreviations	1-48
Chapter 2 Before Use	2-1
2.1 Unpacking and Installation	2-2
2.2 Part Names	2-5
2.3 Power Connection	2-13
2.4 Connecting Peripheral Devices	2-15
2.5 Connecting Remote Control Devices	2-16
2.6 Cautions on Handling Optical Fiber Cables	2-18
2.7 Connecting Coaxial Cable	2-20
2.8 Turning Power On/Off	2-22
2.9 Setting Control Panel	2-24
2.10 Precautions for Preventing Damage	2-30
2.11 Windows Security Measures	2-38
Chapter 3 Measurement Examples	3-1
3.1 Measuring Bit Error Rate	3-2
3.2 Measuring Waveform	3-4
3.3 Measuring Multichannel Optical Module Bit Error Rate	3-10

1
2
3
4
5
6
7
8
Appendix
Index

Chapter 4 Screen Operation..... 4-1

4.1	Window Configuration	4-2
4.2	Data Input Method	4-5
4.3	Setting System Menu	4-8
4.4	Multi-channel Signal Output	4-19
4.5	Simultaneous Measurement Start and Stop at Multi-channels.....	4-20
4.6	Linking Measurement Settings for Multiple Channels.	4-21
4.7	Displaying BER Measurement Results for Multiple Channels	4-22
4.8	Displaying Date/Time and Status	4-23

Chapter 5 How to Operate BERT 5-1

5.1	Procedure for Generating Pulse Signal.....	5-2
5.2	PPG/ED Panel.....	5-3
5.3	Setting Restrictions	5-28

Chapter 6 How to

Operate Sampling Oscilloscope... 6-1

6.1	Measurement Procedure.....	6-2
6.2	Explanation of Windows.....	6-3
6.3	Calibration and Adjustment	6-62
6.4	Setting CRU.....	6-67
6.5	Setting Rate.....	6-71
6.6	Setting Pattern Length	6-74
6.7	Collecting Data	6-76
6.8	Adjusting Scales	6-82
6.9	Measuring Waveform.....	6-88

Chapter 7 Performance Test 7-1

7.1	Performance Test for Pulse Pattern Generator	7-2
7.2	Performance Test for Error Detector.....	7-12
7.3	Performance Test for Sampling Oscilloscope	7-23

Chapter 8 Maintenance 8-1

- 8.1 Daily Maintenance8-2
- 8.2 Replacement of Optical Connector.....8-3
- 8.3 Optical Connector/Optical Adapter Cleaning.....8-5
- 8.4 Displaying Software Version.....8-8
- 8.5 Updating Software8-9
- 8.6 Adding an Option License8-10
- 8.7 Initializing Corrected Data8-14
- 8.8 System Recovery Function8-15
- 8.9 Calibration8-31
- 8.10 Storage.....8-32
- 8.11 Transporting and Disposal8-33

Appendix A Specifications A-1

Appendix B Initial Values B-1

Appendix C File Specifications..... C-1

Appendix D Performance Test Record Form . D-1

Appendix E Bibliography.....E-1

IndexIndex-1

1
2
3
4
5
6
7
8
Appendix
Index

Chapter 1 Outline

This chapter explains the MP2110A BERTWave configuration, features, and technical terms used in this manual.

1.1	Introduction of BERTWave.....	1-2
1.1.1	MP2110A BERTWave.....	1-3
1.1.2	MP2100B BERTWave.....	1-9
1.2	Configuration	1-10
1.2.1	Standard Configuration	1-10
1.2.2	Options	1-13
1.2.3	Optional Accessories.....	1-15
1.3	Features	1-17
1.4	Intended Use	1-18
1.5	Technical Terms	1-21
1.6	Abbreviations	1-48

1.1 Introduction of BERTWave

The BERTWave is a measuring instrument that combines the functions of a pulse pattern generator (PPG), bit error detector (ED) and sampling oscilloscope all-in-one instrument.

The PPG is a digital signal generator that can edit the data rate, the voltage level of the pulse, and the pattern of data to be transmitted. The ED compares the received data bit string with the expected data a bit string and calculates the number of different bits (bit error count). It calculates the bit error rate from the number of received bits and the bit error account. The voltage level for recognizing “0” and “1” of the digital signal, and the data bit string (pattern) can be edited.

The sampling oscilloscope displays the periodic signal waveform. An Eye diagram can be displayed by summing the signal waveforms and signal waveforms can be analyzed and mask tested.

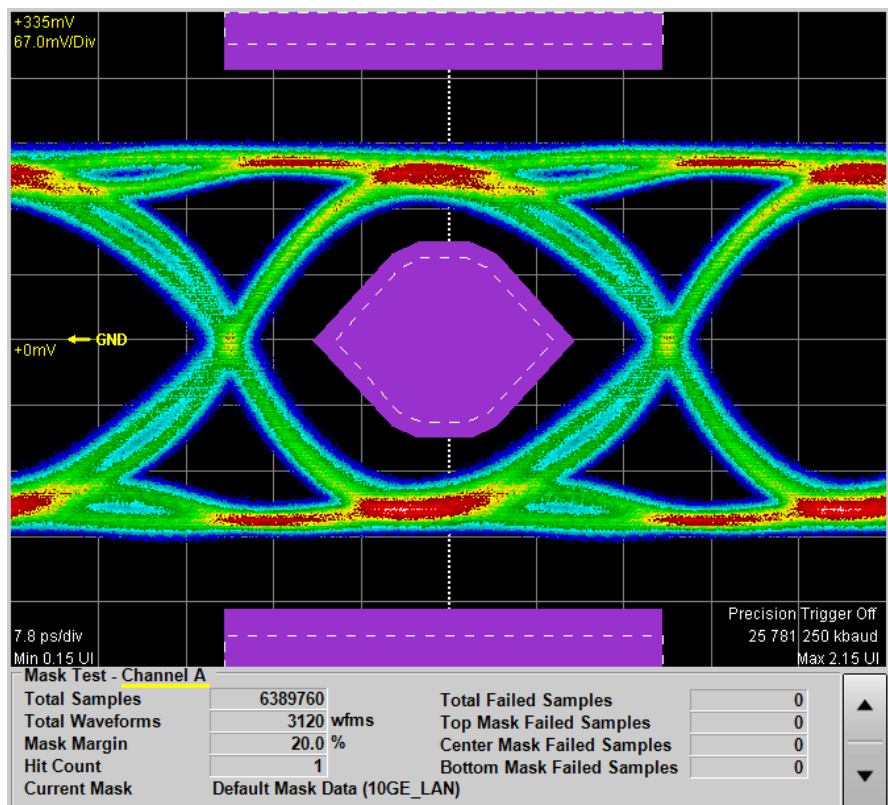

Figure 1.1-1 Mask Test Waveform

1.1.1 MP2110A BERTWave

MP2110A BERTWave (MP2110A) is a measuring instrument combining the BERT (Bit Error Rate Tester) and the sampling oscilloscope. It is used by connecting with the monitor, key board, and mouse as the same as PC. It is controlled remotely using Ethernet or GPIB (General Purpose Interface Bus).



Figure 1.1.1-1 MP2110A External View

MP2110A is a measuring instrument that evaluates the electronic devices such as 100G bit Ethernet (100GbE), OTU4, 32G Fiber Channel (32GFC). It performs the bit error rate test and waveform observation for the signals of bit rate “24.3 to 28.2 Gbit/s” used in the communication standards.

The bit error rate test and wave form observation for the signals of bit rate “10 Gbit/s” can be performed by installing the MP2110A-x93 PPG/ED Bit Rate expansion.

By installing the MP2110A-x95 PAM4 Analysis Software, MP2110A can monitor waveforms of PAM4 signals used by electronic devices, for example, 200GbE, 400GbE and 64GFC.

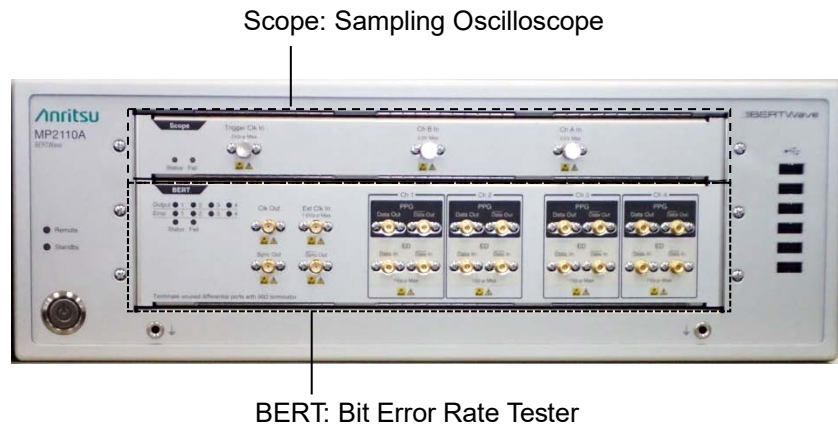

Figure 1.1.1-2 Front Panel of MP2110A

The input connectors of the sampling oscilloscope can be selected by specifying the option.

Table 1.1.1-1 Sampling Oscilloscope Input Connectors

Options Number	Channel A			Channel B			Channel C		Channel D	
	Electrical	Optical	Optical	Electrical	Optical	Optical	Optical	Optical	Optical	Optical
	K	MMF*1	SMF*2	K	MMF*1	SMF*2	MMF*1	SMF*2	MMF*1	SMF*2
MP2110A-x21	✓			✓						
MP2110A-x22, MP2110A-x32, MP2110A-x42		✓	✓		✓	✓				
MP2110A-x23, MP2110A-x33, MP2110A-x43	✓				✓	✓				
MP2110A-x25, MP2110A-x35, MP2110A-x45						✓				
MP2110A-x26, MP2110A-x36, MP2110A-x46					✓					
MP2110A-x30, MP2110A-x40			✓			✓		✓		✓
MP2110A-x39, MP2110A-x49		✓			✓		✓		✓	

*1: For a multi-mode fiber

*2: For a single-mode fiber

Note:

MP2110A-x22, x23, x25, x26, x40, x42, x43, x45, x46, x49 and MP2110A-x30, x32, x33, x35, x36, x39 have different reference receiver properties (Bessel filter approximation property) of optical channel. MP2110A-x30, x32, x33, x35, x36, and x39 are adjusted to have flat baseband properties.

BERT (Bit Error Rate Tester) uses PPG (Pulse Pattern Generator) and ED (Error Detector) together.

The number of BERT channels can be selected by specifying the option.

Table 1.1.1-2 Number of BERT Channels

Option Number	Number of Channels
MP2110A-x11	1
MP2110A-x12	2
MP2110A-x14	4

In this document, multiple option names are collectively called as follows.

BERT option: MP2110A-x11, MP2110A-x12, and MP2110A-x14

Scope option: MP2110A-x21, MP2110A-x22, MP2110A-x23,
MP2110A-x25, MP2110A-x26, MP2110A-x30,
MP2110A-x32, MP2110A-x33, MP2110A-x35,
MP2110A-x36, MP2110A-x39, MP2110A-x40,
MP2110A-x42, MP2110A-x43, MP2110A-x45,
MP2110A-x46, and MP2110A-x49

When one of the following options is installed, MP2110A can generate a trigger clock for the sampling oscilloscope from the input signal.

MP2110A-x54 Clock Recovery (Electrical/Optical)

MP2110A-x55 26G/53Gbaud Clock Recovery (SM Optical)

By installing MP2110A-x95 PAM4 Analysis Software, PAM4 waveform can be analyzed.

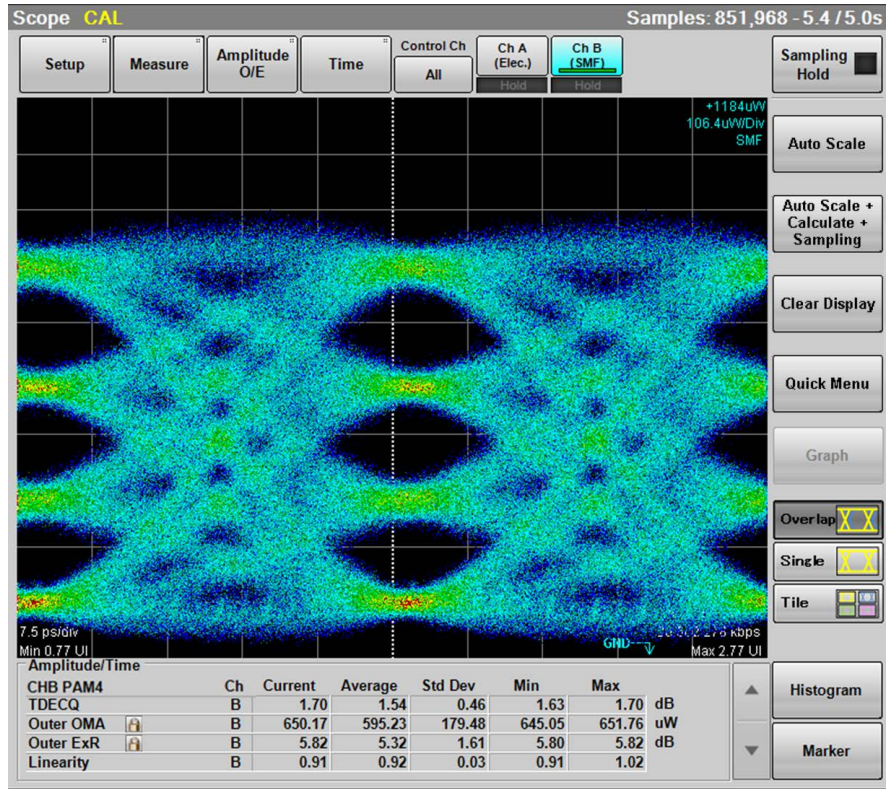

Figure 1.1.1-3 Example of PAM4 Waveform Analysis

By installing MP2110A-x96 Jitter Analysis Software, jitter analysis result can be displayed.

1

Outline



Figure 1.1.1-4 Example of Jitter Analysis

By installing MP2110A-x98 Signal Processing Software, the MP2110A can perform analysis using CTLE and De-embedding.

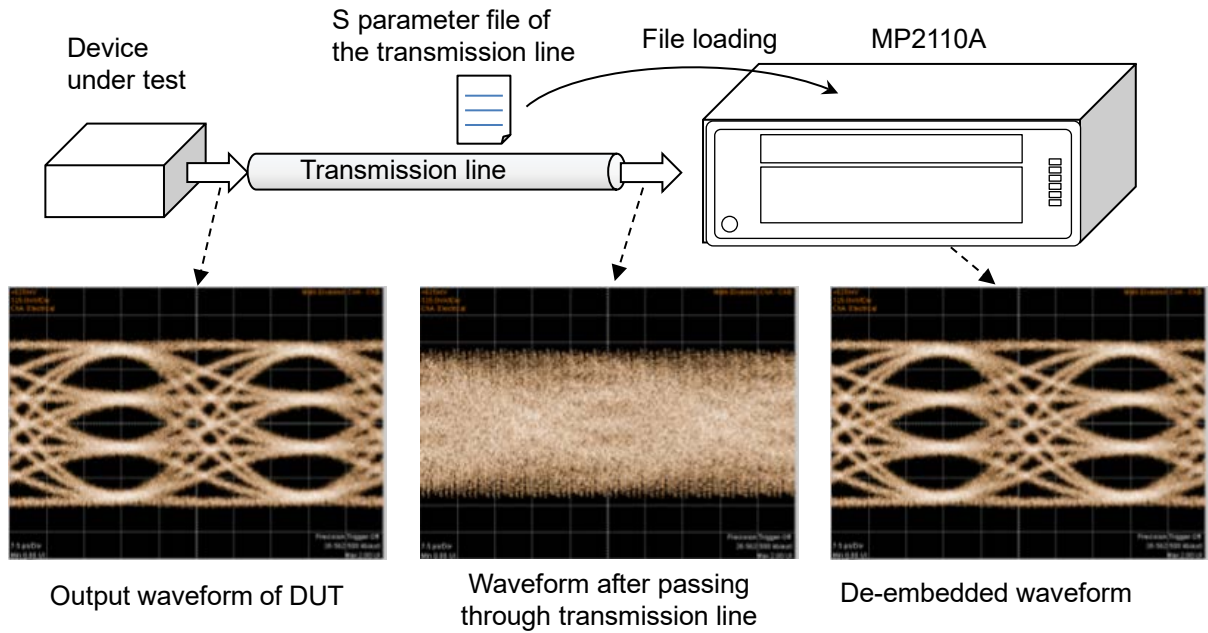

Figure 1.1.1-5 Example of De-Embedding

1.1.2 MP2100B BERTWave

MP2100B BERTWave supports the bit rate from STM-1 to 10GbE. It evaluates the 40 Gbps communication devices such as 40GbE using PPG and ED for 4 channels.

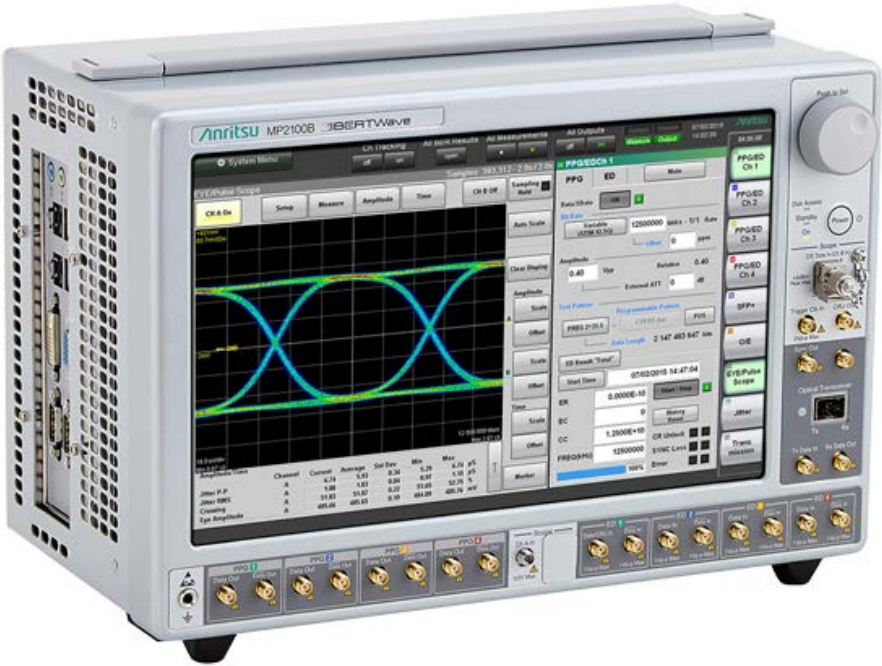

Figure 1.1.2-1 MP2100B External View

MP2100B BERTWave is a space-saving measuring instrument that can operate using the 12.1-inch touch panel. The SFP slot and O/E converter can be added as the option.

Refer to the following website for the MP2100B BERTWave information.
<https://www.anritsu.com/en-us/test-measurement/products/mp2100b>

1.2 Configuration

1.2.1 Standard Configuration

The following table lists the standard configuration of the MP2110A.

Table 1.2.1-1 Standard Configurations

Item	Model/ Ordering No.	Product Name	Q'ty	Remarks
Main unit	MP2110A	BERTWave	1	
Accessories		POWER CORD	1	Contained in accessory box.
	J1627A	GND connection cable	1	
	Z1364A	MX210000A BERTWave Control Software CD-ROM	1	
	J0617B	Replaceable optical connector (FC-PC)	*1	
	J1632A	TERMINATOR	*1	
	J1341A	OPEN	*1	Coaxial connector cover
	J1763A	U Link Coaxial Cable (K)	1*2	
	J1764A	U Link Coaxial Cable (SMA)	1*2	
	Z0397A	FC Adaptor Cap	*1	

*1: Quantity depends on the options. Refer to Table 1.2.1-2 to Table 1.2.1-4.

*2: Only when MP2100A-x54 is installed.

Table 1.2.1-2 Connection Destination and Quantity of J0617B and Z0397A

Option Number	Connection Destination	Q'ty
MP2110A-x30, MP2110A-x40	Optical In SMF A, B, C, D	4
MP2110A-x39, MP2110A-x49	Optical In MMF A, B, C, D	4
MP2110A-x22, MP2110A-x32, MP2110A-x42	Ch A In SMF, Ch A In MMF, Ch B In SMF, Ch B In MMF	4
MP2110A-x23, MP2110A-x33, MP2110A-x43	Ch B In SMF, Ch B In MMF	2
MP2110A-x25, MP2110A-x35, MP2110A-x45	Ch B In SMF	1
MP2110A-x26, MP2110A-x36, MP2110A-x46	Ch B In MMF	1
MP2110A-x55	Optical SMF Data In, Data Out	2

Table 1.2.1-3 Connection Destination and Quantity of J1632A

Option Number	Connection Destination	Q'ty
MP2110A-x11	Data Out×1, $\overline{\text{Data}}$ Out×1, $\overline{\text{Sync}}$ Out×1	3
MP2110A-x12	Data Out×2, $\overline{\text{Data}}$ Out×2, $\overline{\text{Sync}}$ Out×1	5
MP2110A-x14	Data Out×4, $\overline{\text{Data}}$ Out×4, $\overline{\text{Sync}}$ Out×1	9
MP2110A-x54	O/E Monitor Out ×1	1*

*: When MP2110A-x22, MP2110A-x23, MP2110A-x25, MP2110A-x26, MP2110A-x30, MP2110A-x32, MP2110A-x33, MP2110A-x35, MP2110A-x36, MP2110A-x39, MP2110A-x40, MP2110A-x42, MP2110A-x43, MP2110A-x45, MP2110A-x46, or MP2110A-x49 is installed.

Table 1.2.1-4 Connection Destination and Quantity of J1341A

Option Number	Connection Destination	Q'ty
MP2110A-x11	Ext Clk In, Clk Out, Sync Out×1, Data In×1, Data In×1	5
MP2110A-x12	Ext Clk In, Clk Out, Sync Out×1, Data In×2, Data In×2	7
MP2110A-x14	Ext Clk In, Clk Out, Sync Out×1, Data In×4, Data In×4	11
MP2110A-x30, MP2110A-x39, MP2110A-x40, MP2110A-x49	Trigger Clk In	1
MP2110A-x21	Trigger Clk In, Ch A In, Ch B In	3
MP2110A-x22, MP2110A-x32, MP2110A-x42	Trigger Clk In	1
MP2110A-x23, MP2110A-x33, MP2110A-x43	Trigger Clk In, Ch A In	2
MP2110A-x25, MP2110A-x35, MP2110A-x45	Trigger Clk In	1
MP2110A-x26, MP2110A-x36, MP2110A-x46	Trigger Clk In	1
MP2110A-x54	CRU In×1, CRU Out×1	2
MP2110A-x55	Recovered Clock Out×1	1

Table 1.2.2-1 MP2110A Option List

Option Number	Name
MP2110A-x11	1CH BERT ^{*1,*2}
MP2110A-x12	2CH BERT ^{*1,*2}
MP2110A-x14	4CH BERT ^{*1,*2}
MP2110A-x21	Dual Electrical Scope ^{*1,*3}
MP2110A-x22	Dual Optical Scope ^{*1,*3}
MP2110A-x23	Optical and Single-ended Electrical Scope ^{*1,*3}
MP2110A-x24	Precision Trigger ^{*4}
MP2110A-x25	Optical Scope for Singlemode ^{*1,*3}
MP2110A-x26	Optical Scope for Multimode ^{*1,*3}
MP2110A-x30	Quad Optical Scope for Singlemode Baseband Flat ^{*1,*3}
MP2110A-x32	Dual Optical Scope Baseband Flat ^{*1,*3}
MP2110A-x33	Optical and Single-ended Electrical Scope Baseband Flat ^{*1,*3}
MP2110A-x35	Optical Scope for Singlemode Baseband Flat ^{*1,*3}
MP2110A-x36	Optical Scope for Multimode Baseband Flat ^{*1,*3}
MP2110A-x39	Quad Optical Scope for Multimode Baseband Flat ^{*1,*3}
MP2110A-x40	Quad Optical Scope for Singlemode ^{*1,*3}
MP2110A-x42	Dual Optical Scope ^{*1,*3}
MP2110A-x43	Optical and Single-ended Electrical Scope ^{*1,*3}
MP2110A-x45	Optical Scope for Singlemode ^{*1,*3}
MP2110A-x46	Optical Scope for Multimode ^{*1,*3}
MP2110A-x49	Quad Optical Scope for Multimode ^{*1,*3}
MP2110A-x54	Clock Recovery (Electrical/Optical) ^{*5}
MP2110A-x55	26G/53Gbaud Clock Recovery (SM Optical) ^{*6}
MP2110A-x59	25G Clock Recovery Range Extension ^{*5,*7}
MP2110A-x60	Optical Scope Custom Gain Adjustment ^{*5}
MP2110A-x61	Low Noise and Multimode Support for Opt.040 ^{*8}
MP2110A-x93	PPG/ED Bit Rate Extension ^{*9}
MP2110A-x95	PAM4 Analysis Software ^{*5}
MP2110A-x96	Jitter Analysis Software ^{*5}
MP2110A-x98	Signal Processing Software ^{*5}

- *1: At least one of these options are required.
- *2: Select one of the BERT options.
- *3: Select one of the Scope options.
- *4: One of the Scope options is required, except the following:
MP2110A-x30, MP2110A-x39, MP2110A-x40, MP2110A-x49
- *5: One of the Scope options is required.
- *6: Cannot be installed with BERT options.
- *7: MP2110A-x54 is required.
- *8: MP2110A-x40 is required.
- *9: One of the BERT options is required.

1.2.3 Optional Accessories

Table 1.2.3-1 shows the optional accessories for MP2110A.

Table 1.2.3-1 Optional Accessories

Model/Order No.	Name
B0734A	Carrying Case
B0735A	Rack Mount Kit
G0307A	Clock Recovery Module (<2.667G)
G0342A	ESD Discharger
G0364A	100G LR4 1310 nm QSFP28
G0366A	100G SR4 850 nm QSFP28
J0617B	Replaceable optical connector (FC-PC)
J0618D	Replaceable Optical Connector (ST)
J0618E	Replaceable Optical Connector (DIN)
J0619B	Replaceable Optical Connector (SC)
J0635A	FC•PC-FC•PC-1M-SM
J0660A	SC•PC-SC•PC-1M-SM
J0839A	SC•PC-SC•PC-1M-GI
J0893A	FC•PC-FC•PC-1M-GI
J1139A	FC•PC-LC•PC-1M-SM
J1341A	Open (Coaxial connector cover)
J1342A	Coaxial Cable 0.8 m
J1343A	Coaxial Cable 1 m
J1344A	LC•PC-LC•PC-1M-SM
J1345A	SC•PC-LC•PC-1M-SM
J1346A	LC•PC-LC•PC-1M-GI (62.5/125)
J1347A	FC•PC-LC•PC-1M-GI (62.5/125)
J1348A	SC•PC-LC•PC-1M-GI (62.5/125)
J1349A	Coaxial Cable 0.3 m
J1359A	Coaxial Adaptor (K-P.K-J,SMA)
J1439A	Coaxial cable (0.8 m, K connector)
J1510A	Pick OFF Tee
J1519A	Optical Fiber Cord (MM, 12FIBER, MPO, 3M)
J1551A	Coaxial skew match cable (0.8 m, K connector)
J1632A	Terminator

Table 1.2.3-1 Optional Accessories (Cont'd)

Model/Order No.	Name
J1681A	MPO Loopback Cable
J1682A	MPO to FC convert cable
J1763A	U Link Coaxial Cable (K)
J1764A	U Link Coaxial Cable (SMA)
J1819A	U Link Coaxial Cable (SMA)
J1824A	Fixed Optical Attenuator (1dB)
J1825A	Fixed Optical Attenuator (2dB)
J1826A	Fixed Optical Attenuator (3dB)
J1827A	Fixed Optical Attenuator (5dB)
W3831AE	MP2110A BERTWave Operation Manual* ¹
W3773AE	BERTWave Series Remote Control Operation Manual* ¹
Z0306A	Wrist Strap
Z0541A	USB Mouse
Z0914A	Ferrule Cleaner
Z0915A	Replacement Reel for Ferrule Cleaner* ²
Z1944A	LCD Monitor
Z1952A	HDMI to VGA Adapter

*1: Printed version

*2: 6 rolls

1.3 Features

The MP2110A has the following features:

- Bit error rate measurement and waveform monitoring up to 28.2 Gbit/s
- Bit error rate measurement and waveform monitoring in one instrument
- 4-channel simultaneous BER measurement, handy for CFP4 module and QSFP module testing (MP2110A-x14)
- Accurate waveform monitoring using low residual jitter of 200 fs and rms (typical value) (MP2110A-x24)
- For sampling oscilloscope:
 - EYE analysis in short time using high-speed sampling
- Compatibility of remote commands with previous Anritsu measuring instruments
- One or both of the following clock recovery units can be installed to the sampling oscilloscope:
 - MP2110A-x54: 25.5 to 28.2 Gbaud
 - MP2110A-x55: 25.5 to 28.9 and 51.0 to 58.0 Gbaud
- MP2110A-x95 for PAM4 (Pulse Amplitude Modulation) waveform analysis
- MP2110A-x96 for jitter analysis from the waveform obtained by Sampling Oscilloscope
- Capable of waveform analysis using CTLE and De-embedding. (MP2110A-x98)

1.4 Intended Use

The MP2110A can be used for the following applications:

- Evaluating optical transceivers used in optical fiber communications
- Evaluating parts for digital communications

Evaluating optical transceivers used in optical fiber communications

Computer-based and public communications systems transmit and receive digitalized signals. These signals are converted to electrical or optical signals optimized for passage through the transmission path, which may be either coaxial cable or optical fiber. In the communication where the bit rate is around 100 Gbit/s, the optical transceiver based on the multisource agreement such as CFP4 and QSFP28 is used.

The optical transceiver includes the transmitters and receivers of which the bit rate is 25 Gbit/s for 4 circuits. The following figure shows a CFP4 block diagram for 100 Gbit/s.

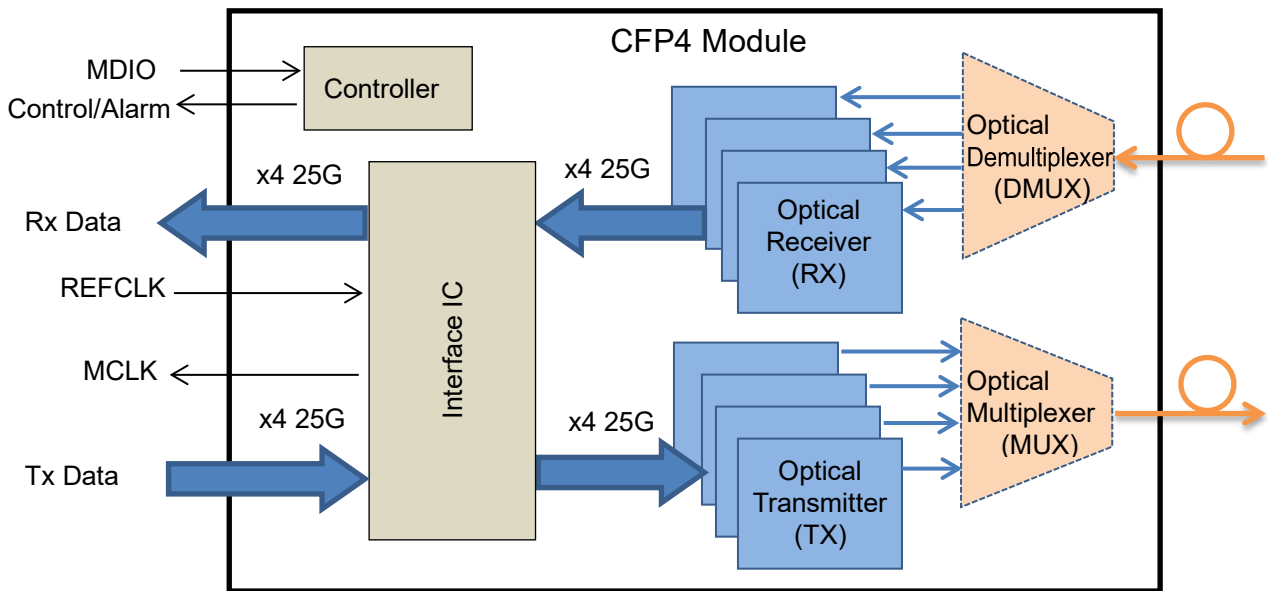

Figure 1.4-1 Functional Block Diagram of 100 Gbit/s CFP4

The receiver sensitivity which is one of the performances in the optical transceiver is calculated by measuring the bit error rate and optical power.

The following figure shows a connection example between the DUT and the measuring instruments when the DUT is the CFP4 module.

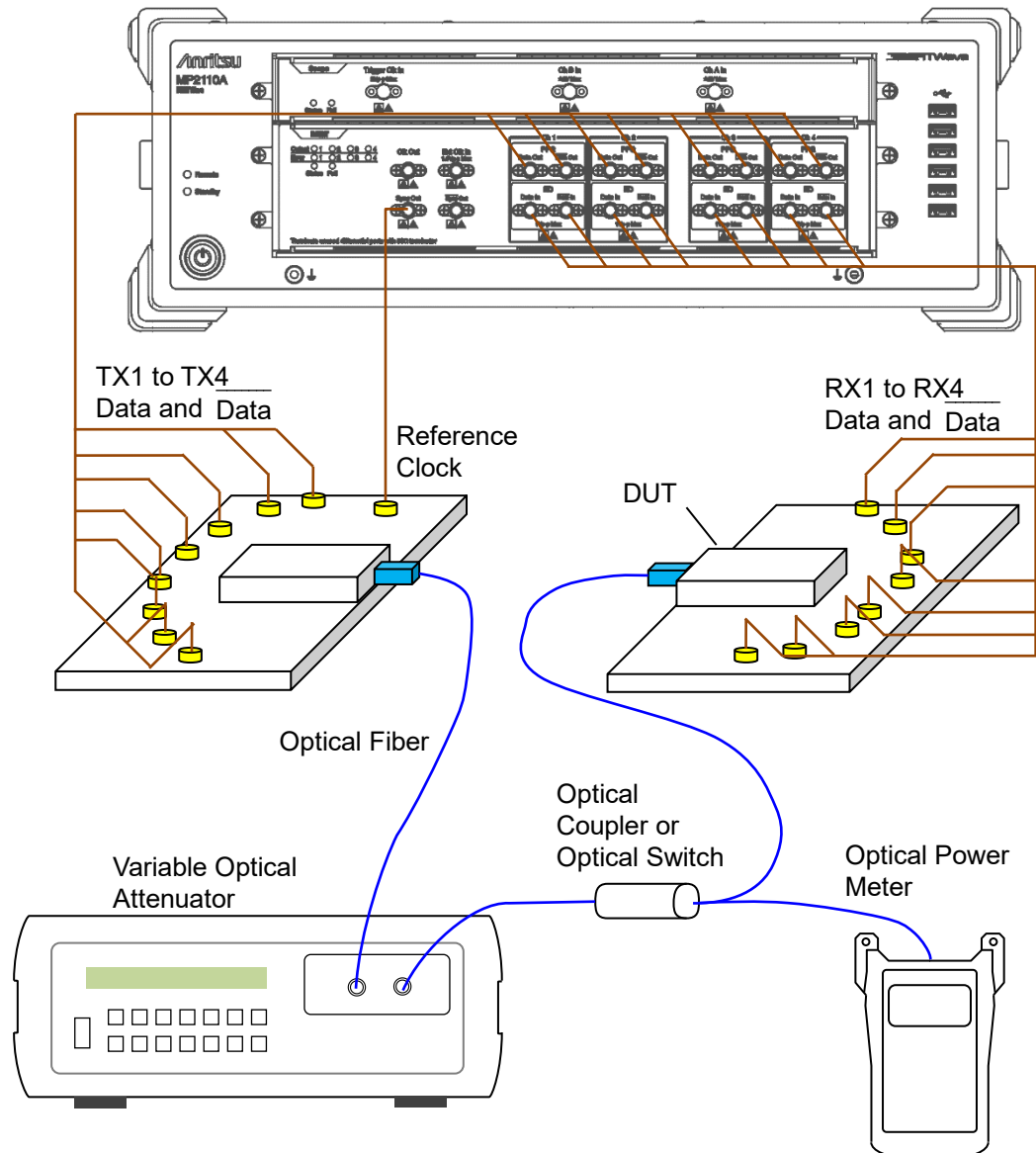

Figure 1.4-2 Connection Example of Receiver Sensitivity Measurement

The output waveform of the optical transceiver is evaluated using the pulse pattern generator and sampling oscilloscope. The output of optical transceiver is the wavelength multiplexed optic. Therefore, input only the optic of the wavelength to be measured using the optical demultiplexer or optical filter to MP2110A.

The following figure shows a connection example between the DUT and the measuring instruments when the DUT is the CFP4 module.

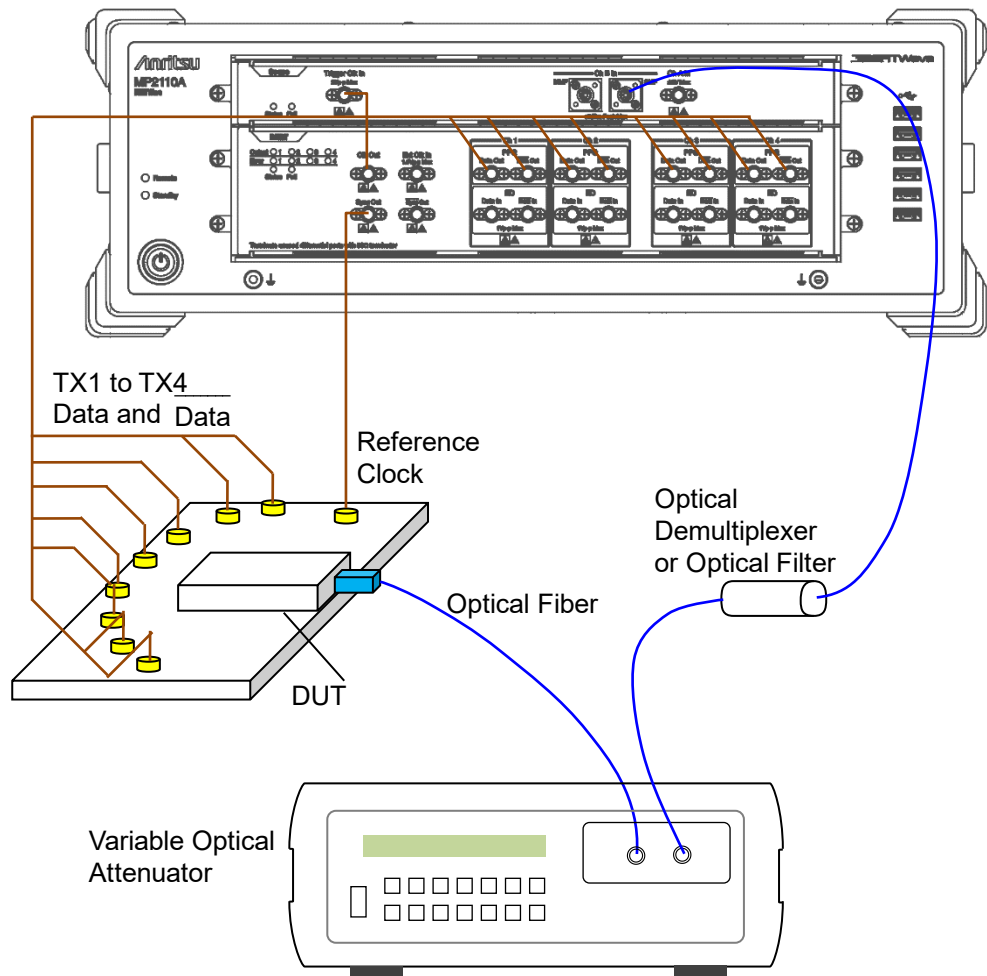

Figure 1.4-3 Connection Example of Waveform Measurement

1.5 Technical Terms

This section explains the technical terms used in this manual.

BER: Bit Error Rate

The Bite Error Rate is the ratio of the total received bits and error bits. It depends on the SNR (signal to noise ratio).

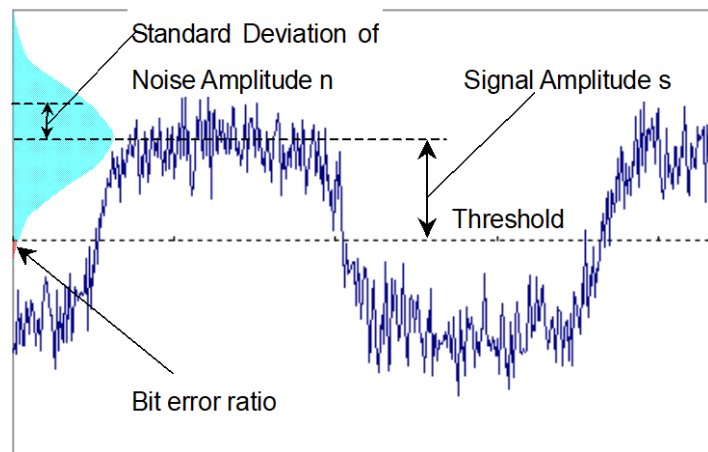

Figure 1.5-1 Bit Error Rate

When the distribution of the noise voltage amplitude is assumed to follow a normal distribution, the standard deviation is assumed to be n and the signal amplitude is s . Bit errors occur when the noise amplitude is larger than the signal amplitude. Consequently, the probability of amplitude occurring is the bit error ratio.

The bit error ratio, BER, is calculated by the following formula.

$$\text{BER} = \frac{1}{\sqrt{2\pi}} \int_{s/n}^{\infty} \exp\left(-\frac{x^2}{2}\right) dx$$

When the SNR is large (greater than 4), the relationship between SNR and BER becomes linear when plotted on a semi-logarithmic graph.

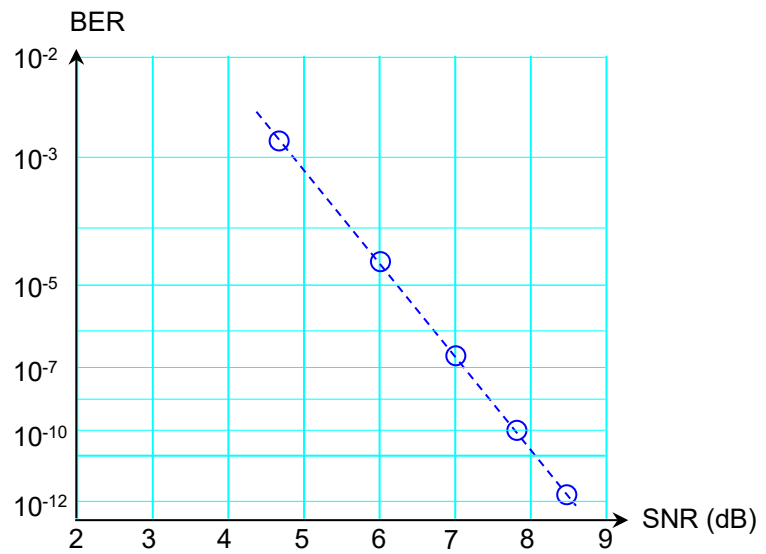

Figure 1.5-2 Relationship between SNR and BER

Bit Rate

The Bit Rate is the speed at which the communications interface transmits and receives data. It is expressed by the number of bits transmitted per second (bit/s or bps).

Bathtub

As an evaluation method of eye pattern waveform, there is a graph that displays the measurement result with time as the horizontal axis and bit error rate as the vertical axis. The left and right edges of the graph are the positions of the cross points of the eye pattern waveform, and have large bit error rates. The center part of the graph is the center part of the eye pattern waveform, and has small bit error rate. This graph is called a Bathtub graph or Bathtub curve line from the form of the graph.

The Jitter analysis software displays the bathtub graph estimated from the histogram of total jitter. The software displays the time with 99% jitter (J2) BER, 10^{-4} jitter (J4), 10^{-9} jitter (J9) specified in the communication standards, and the specified bit error rate such as 10^{-12} or less.

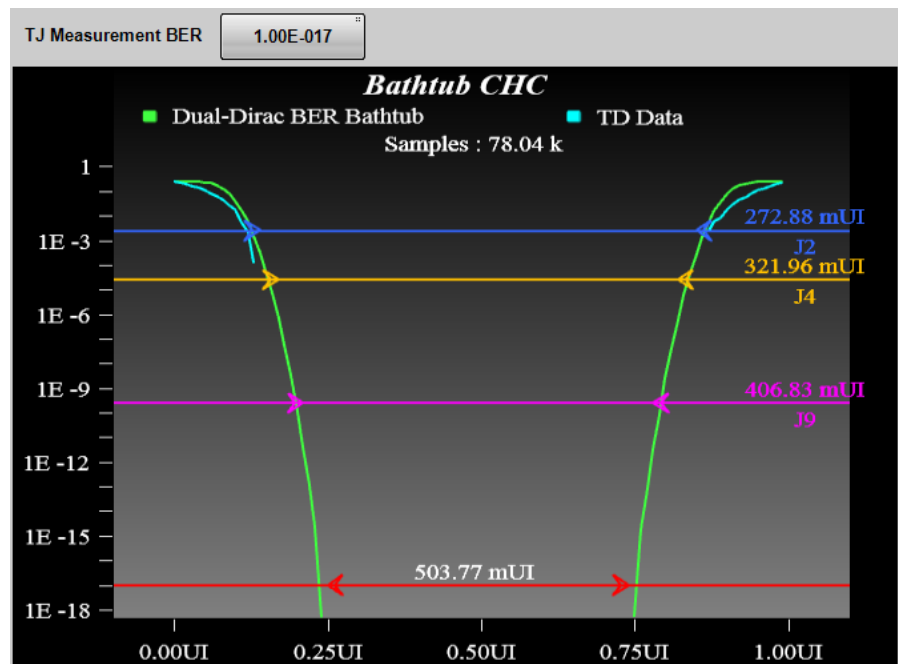

Figure 1.5-3 Example of Bathtub Curve

CTLE (Continues Time Linear Equalizer)

This is a kind of equalizer mainly used on the receiver side, and used for the purpose of compensating the insertion loss of the transmission line. The MP2110A can perform a waveform equalizer processing with the software.

DCD: Duty Cycle Distortion

The duty cycle distortion (DCD) is found from the following equation:

$$\text{DCD} = (t_2 - t_1) / B_p \times 100 \quad (\%)$$

Where,

t_1 : Time at crossing point between 50% level of Eye Amplitude and rising waveform

t_2 : Time at crossing point between 50% level of Eye Amplitude and falling waveform

B_p : Bit cycle

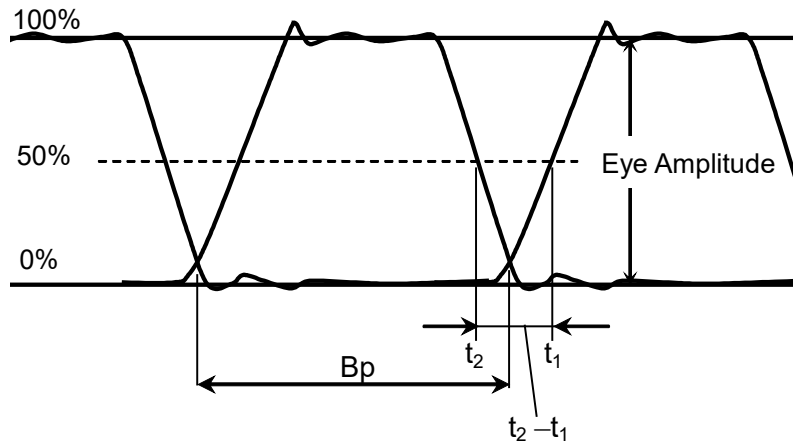

Figure 1.5-4 Duty Cycle Distortion

DDJ vs Bit

The amount of jitter, which is measured for each bit whose pattern changes, is displayed as a graph.

The time difference between the clock and the waveform at the cross point level is measured and the result is plotted on the pattern location.

When the waveform time is slower than the clock, the value is positive, and when the waveform is faster than the clock, the value is negative.

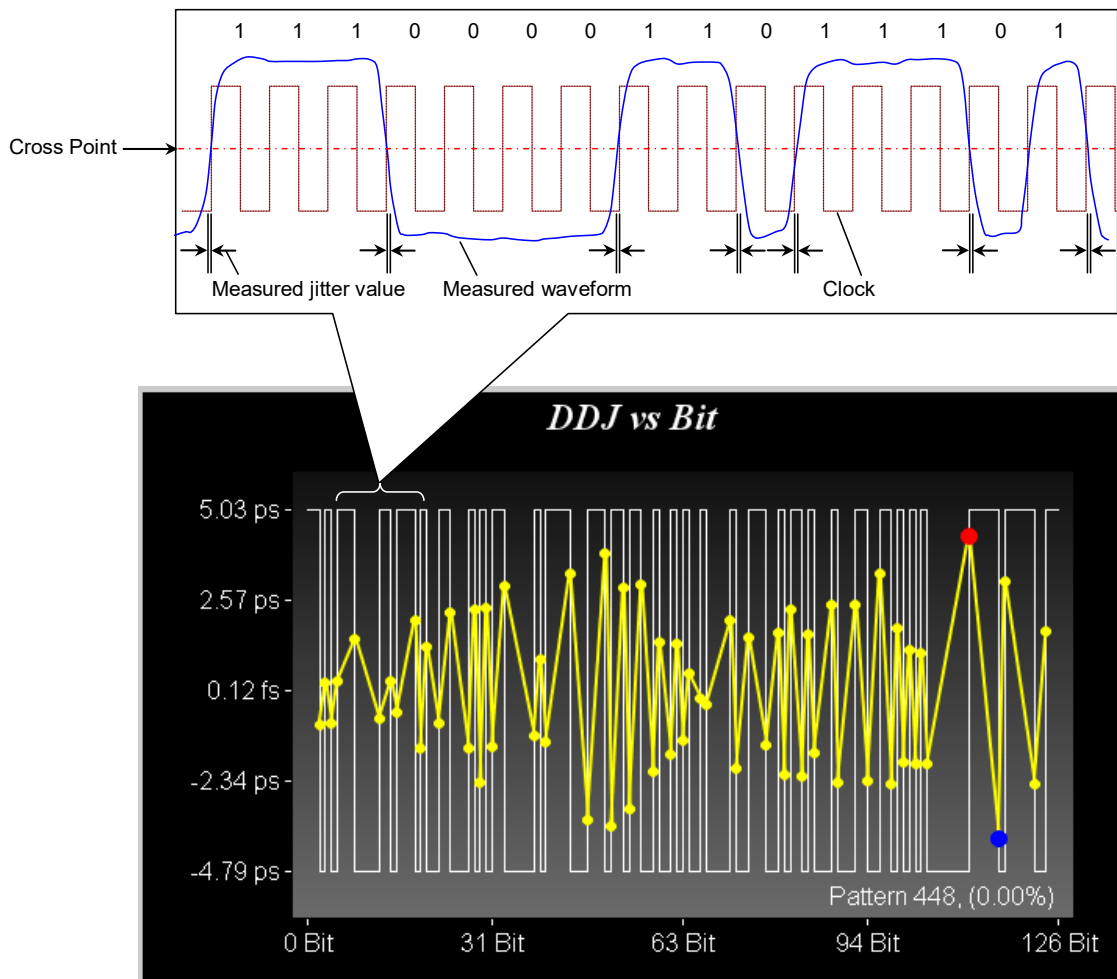

Figure 1.5-5 DDJ vs Bit Measurement Method

DDPWS (Data Dependent Pulse Width Shrinkage)

DDPWS is the amount of pulse width shrinkage by data dependent jitter.

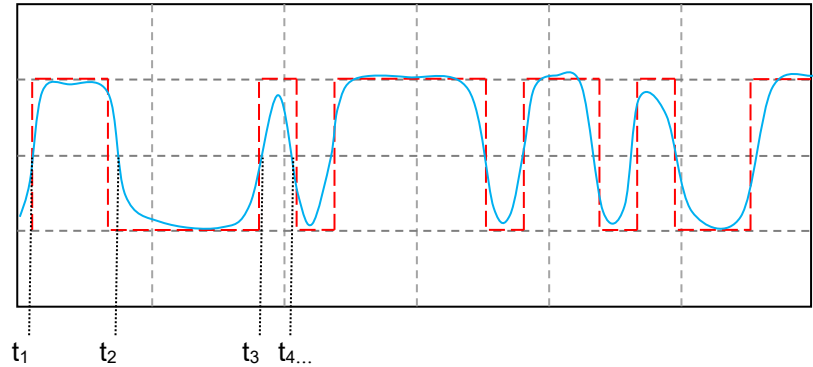

Figure 1.5-6 DDJ Measurement Method

In Figure 1.5-6, the red line is the ideal symbol waveform and the blue line is the measured waveform with jitter. Let $t_1, t_2, t_3 \dots$ be the time of the blue line at the cross point, and let the time differences between the red line and the blue line be $\Delta t_1, \Delta t_2, \Delta t_3 \dots$

DDJ and DDPWS are defined by the following formulas.

$$DDJ = \max(\Delta t_1, \Delta t_2, \Delta t_3, \dots, \Delta t_n) - \min(\Delta t_1, \Delta t_2, \Delta t_3, \dots, \Delta t_n)$$

$$DDPWS = T - \min(t_2 - t_1, t_3 - t_2, t_4 - t_3, \dots, t_n - t_{n-1})$$

T: Symbol cycle

Dual Dirac Estimation

If the jitter elements include DJ, the histogram has multiple peaks at the waveform cross point. Dual Dirac Estimation is a method to estimate RJ and DJ using Dual Dirac function as the fitting curve of this histogram.

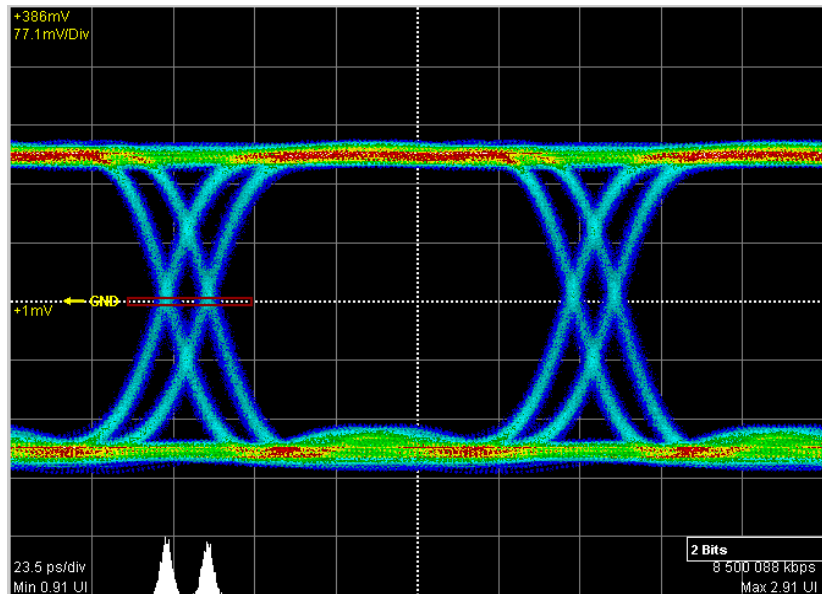

Figure 1.5-7 Histogram of Jitter with DJ

The Dual Dirac distribution is expressed as the combined formula of two normal distributions.

$$PDF(x) = \frac{1}{\sqrt{2\pi}\sigma} \left[\exp\left(-\frac{(x-\mu_L)^2}{2\sigma^2}\right) + \exp\left(-\frac{(x-\mu_R)^2}{2\sigma^2}\right) \right]$$

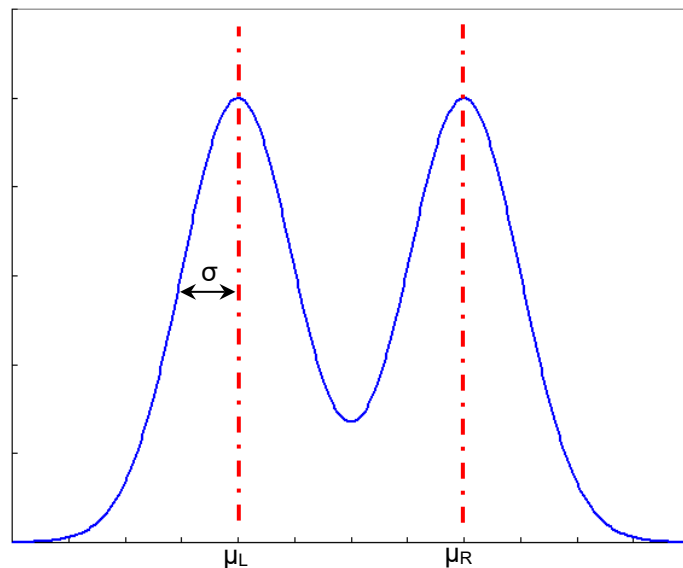

Figure 1.5-8 Dual Dirac Distribution

The Dual Dirac distribution assumes that RJ is the normal distribution and DJ is a constant value. The Jitter Analysis software displays σ and $\mu_R - \mu_L$ of the Dual Dirac distribution approximated from the measured histogram to RJ (d-d) and DJ (d-d) respectively.

Extinction Ratio

The extinction ratio is the ratio of 1 Level and 0 Level; it is used for evaluating optical signal waveforms.

The extinction ratio is calculated by the following formula.

$$\text{Extinction Ratio} = 10 \log_{10} \{ (L_1 - L_D) / (L_0 - L_D) \} \text{ (dB)}$$

L_1 : 1 Level (mW)

L_0 : 0 Level (mW)

L_D : Level without optical input (mW)

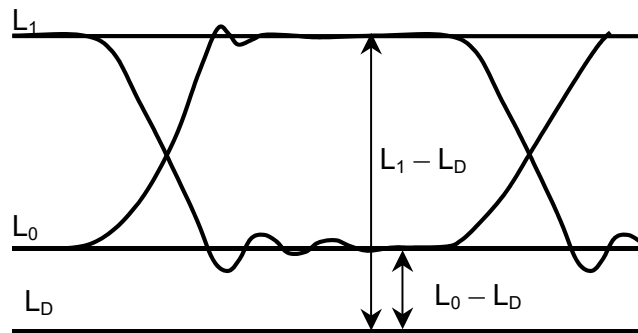

Figure 1.5-9 Extinction Ratio Measurement Level

For the extinction ratio of PAM4, refer to “Outer ExR (Outer Extinction Ratio)”.

Eye Amplitude

For NRZ, eye amplitude is the difference between 1 Level and 0 Level.

Refer to Figure 1.5-21.

In PAM4, eye amplitude is the difference between the levels. There are three of Upper, Middle, Lower. Refer to Figure 1.5-10.

Eye Crossing Time

The Eye Crossing Time is the time between the left end of the window and the point where the Eye amplitude rising and falling waveforms cross.

See Figure 1.5-21.

Eye Crossing Percentage

Eye Crossing Percentage is the ratio of the Eye amplitude rising and falling waveforms. The calculation formula is as follows. Refer to Figure 1.5-21.

$$\text{Crossing} = (\text{crossing point level} - 0 \text{ Level}) / (1 \text{ Level} - 0 \text{ Level})$$

Eye Height

For NRZ, eye height can be calculated by the following formula. Refer to Figure 1.5-21.

$$\text{Eye Height} = (1 \text{ Level} - 3 \sigma_1) - (0 \text{ Level} + 3 \sigma_0)$$

σ_1 : 1 Level Standard Deviation

σ_0 : 0 Level Standard Deviation

For PAM4, eye height varies depending on eye definition method and sample method.

When Sample Timing is **Independent**, the maximum eye height is measured for each eye.

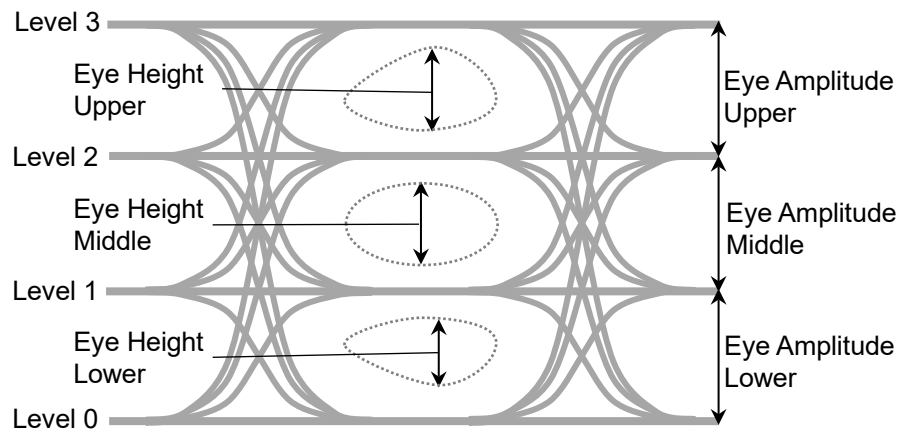

Figure 1.5-10 Eye Amplitudes and Eye Heights of PAM4 Waveform (When Sample Timing is Independent)

When Sample Timing is **Track to Middle Eye Timing**, eye amplitude Upper and eye amplitude Lower are measured at the center position of Middle Eye.

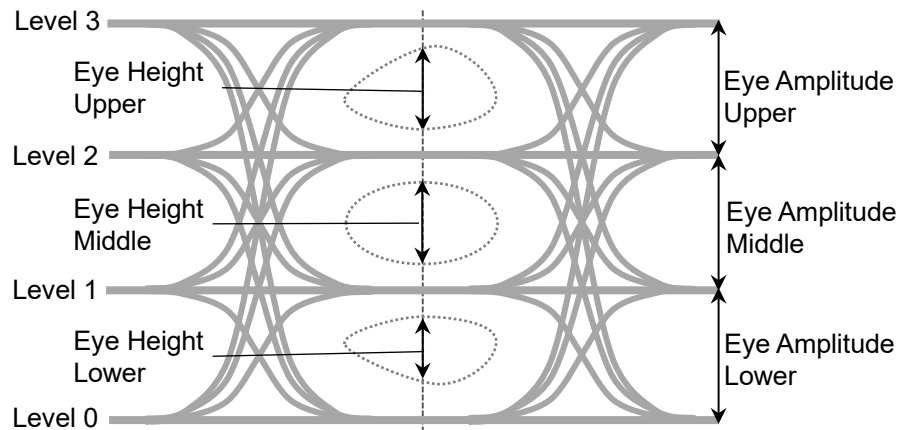

Figure 1.5-11 Eye Amplitudes and Eye Heights of PAM4 Waveform (When Sample Timing is Track to Middle Eye Timing)

Eye Levels, Eye Widths

Eye Widths are the eye widths of the PAM4 waveform. They depend on how the eyes are defined. Eye Levels are the levels to measure eye widths.

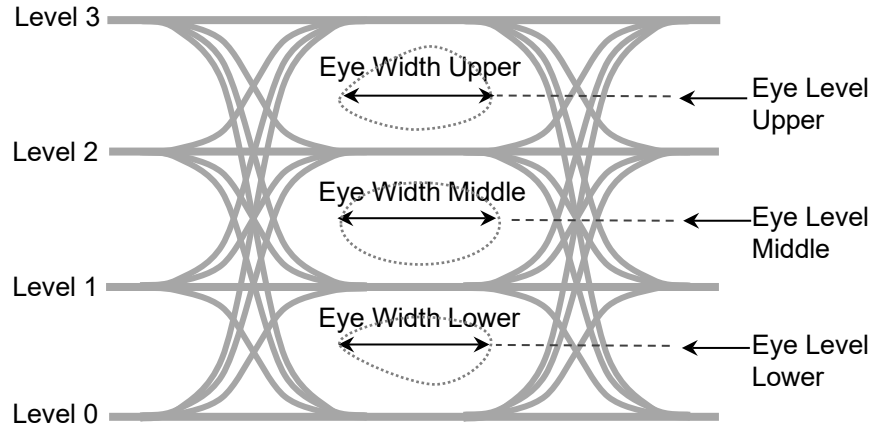

Figure 1.5-12 Eye Level and Eye Width of PAM4 Waveform

Eye Mask

The Eye Mask is the boundary of the eye pattern waveform time and amplitude. The value and waveform are specified by the communications standards.

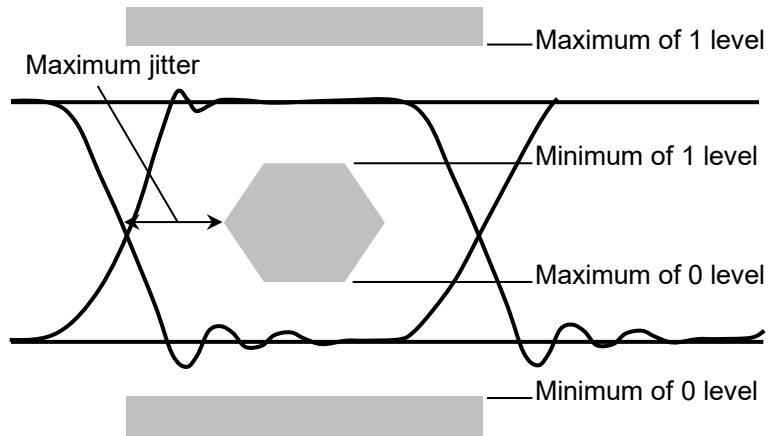

Figure 1.5-13 Example of Eye Mask

Eye Pattern

The Eye Pattern is the pattern created by superimposing the digital waveforms sampled at the same timing.

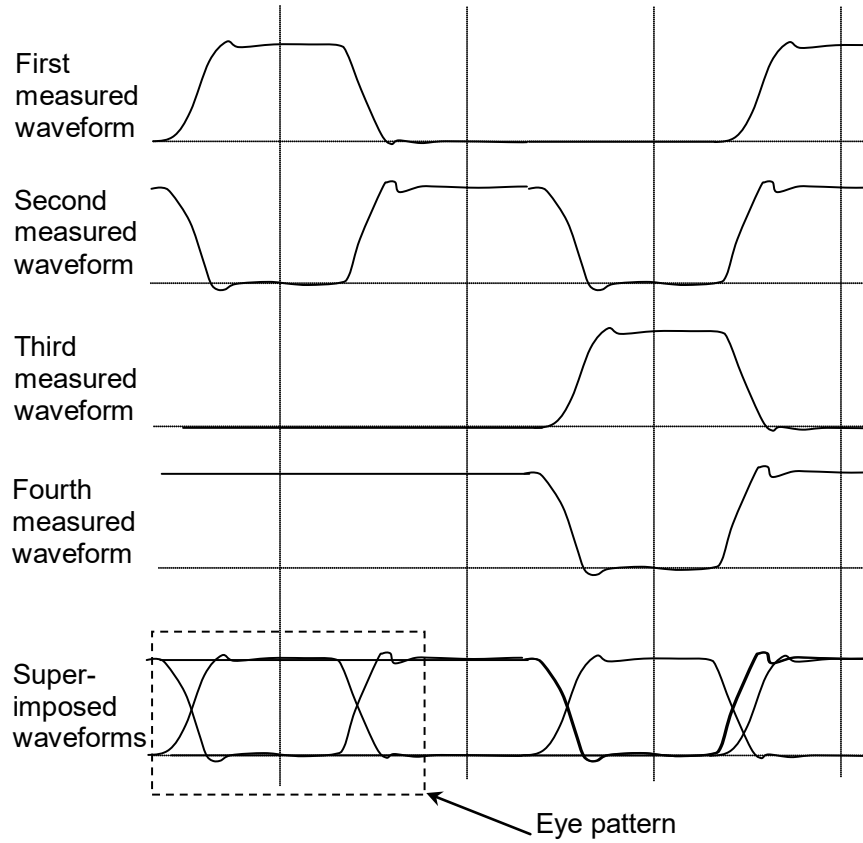

Figure 1.5-14 Eye Pattern Drawing Method

Eye Skews

When PAM4 waveform and Sample Timing is **Independent**, Eye Skews are phase differences between the average value of the center of each eye (Eye Center) and the centers of Upper Eye, Middle Eye and Lower Eye.

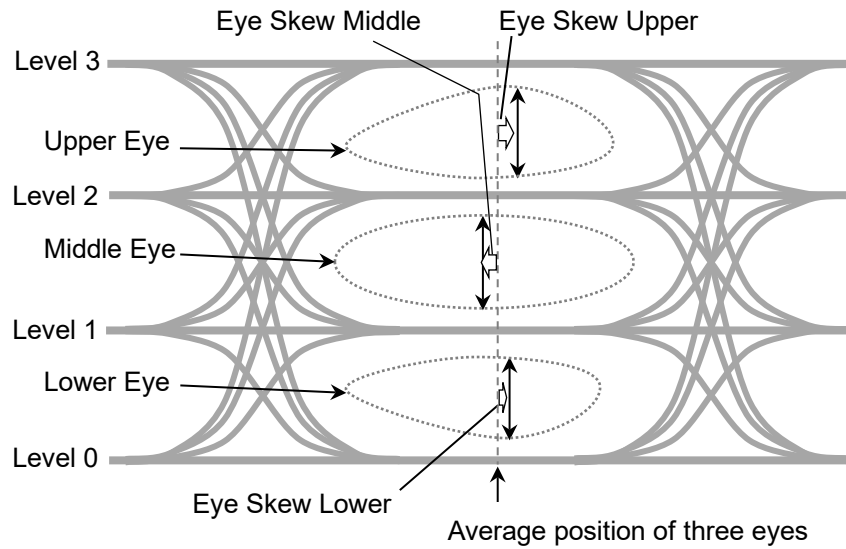

Figure 1.5-15 PAM4 Eye Skews (When Sample Timing is Independent)

When Sample Timing is **Track to Middle Eye Timing**, the eye skew is 0.

Eye Width

Eye Width is equivalent to Eye Height in the horizontal direction. For NRZ, it is calculated from a histogram of the two eye pattern crossing points in the time direction.

$$\text{Eye Width} = (t_2 - 3\sigma_2) - (t_1 + 3\sigma_1)$$

t_1 : Average time of first crossing point

t_2 : Average time of second crossing point

σ_1 : Standard deviation of first crossing point

σ_2 : Standard deviation of second crossing point

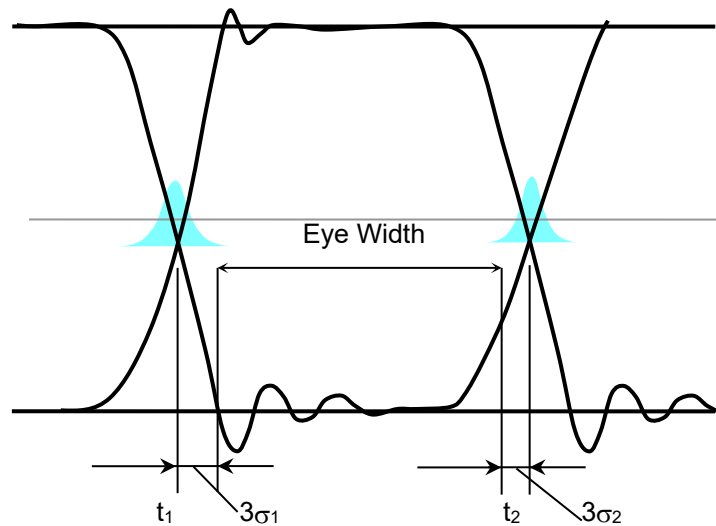

Figure 1.5-16 Eye Width

For PAM4, Eye Width is the width in time axis direction to be the defined bitrate or less. Refer to Figure 1.5-12.

Jitter

Jitter is the variation in the time of the crossover point between the Eye Diagram rising and falling parts of the waveform.

Jitter p-p (Jitter p-p): Full width of histogram in time direction

Jitter RMS (Jitter RMS): Standard deviation of histogram in time direction

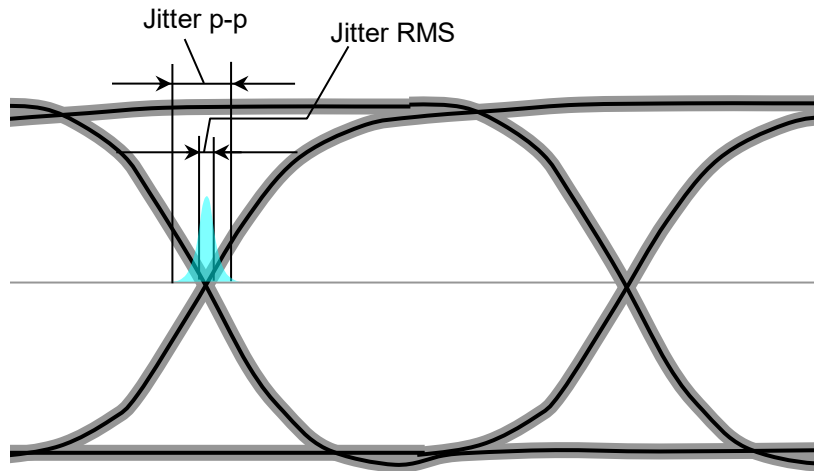

Figure 1.5-17 Jitter p-p and Jitter RMS

The jitter measured with the sampling oscilloscope is the combined values of jitters with various occurrence factors. Actually occurred jitters consist of various jitter elements.

The types of jitter elements which compose actual signals are explained below.

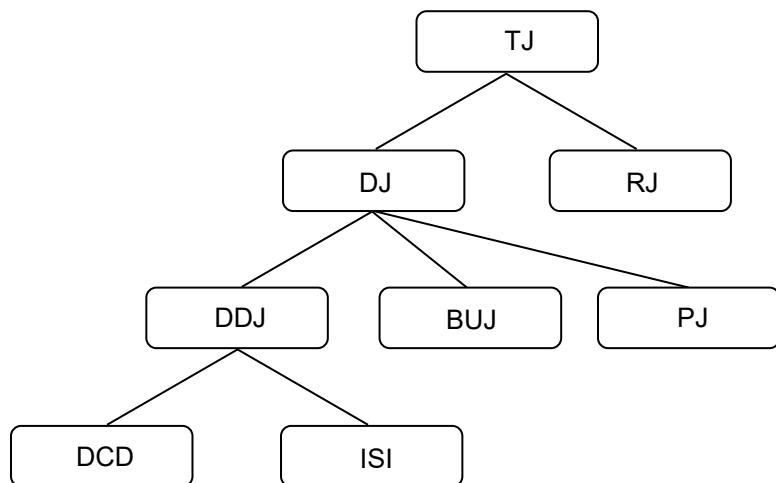

Figure 1.5-18 Jitter Classification

Table 1.5-1 Jitter Type

Abbrev.	Name	Description
TJ	Total Jitter	Jitter of combined RJ and DJ Not a simple sum of RJ and DJ
RJ	Random Jitter	Jitter which occurs with external factors such as thermal noise. It has a characteristic to spread unlimitedly which approaches Gaussian distribution. It is indicated with rms (root mean square) because it spreads unlimitedly.
DJ	Deterministic Jitter	Jitter with upper limit of amount relative to the Random Jitter
BUJ	Bounded Uncorrelated Jitter	Jitter which occurs with external factors such as cross talk effects from adjacent signal lines. It has a random nature like the Random Jitter; however, it is indicated with p-p (peak to peak) because its spreading is limited.
DDJ	Data Dependant Jitter	Jitter which is DJ and the occurrence amount depends on data.
DCD	Duty Cycle Distortion	Occurs with transmission/reception circuit offset distortion difference of High pulse width and Low pulse width.
ISI	Inter Symbol Interference	Occurs due to inadequate bandwidth and reflections caused by impedance mismatching, etc., in the transmission path. When components with no correlation to data are removed, it is defined either as the difference between the fastest and slowest rising edges, or as the difference between the fastest and slowest falling edges.
PJ	Period Jitter	Jitter which is DJ and occurs periodically.

With the communications standards such as IEEE 802.3-2015*, specifications for DDPWS (Data Dependent Pulse Width Shrinkage) have been decided as well as the jitters above.

*: For the formal name, refer to Appendix E “Bibliography”.

Levels p-p, Levels RMS, Level Skews

When measuring the histogram of each level with PAM4 waveform, the peak value of its width is Levels p-p and the standard deviation is Levels RMS.

If Sample Timing is **Independent**, Levels p-p, Levels and RMS are measured at the following positions.

- Level 3 The center of Upper Eye
- Level 2 Halfway between the center of Upper Eye and the center of Middle Eye.
- Level 1 Halfway of the center of Middle Eye and the center of Lower Eye
- Level 0 The center of Lower Eye

Level Skews are differences between the positions measured at each level and their averages.

When Sample Timing is **Track to Middle Eye Timing**, Levels p-p and Levels RMS are measured at the center of Center Eye. And Level Skews are 0.

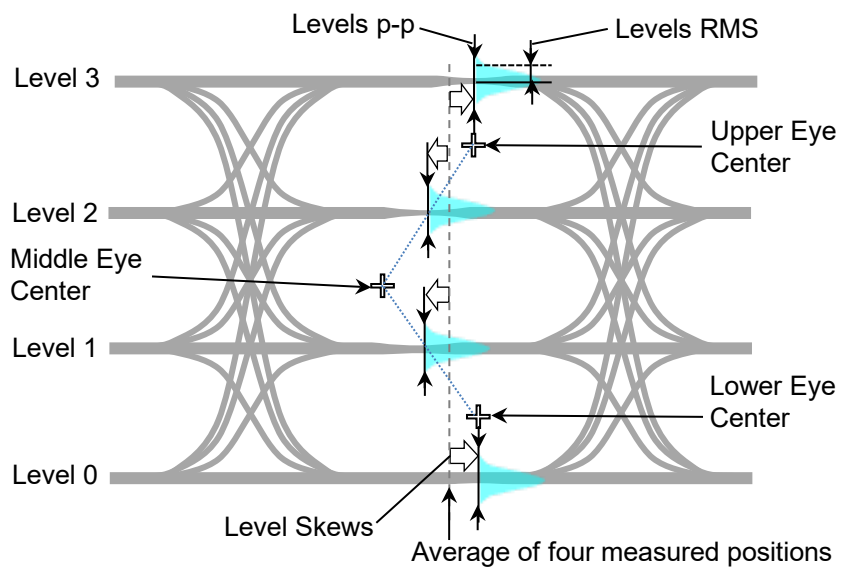

**Figure 1.5-19 PAM4 Levels p-p and Levels RMS
(When Sample Timing is Independent)**

Linearity

It indicates the degree that the three Eye Amplitudes of the PAM4 waveform deviate from one third of the difference between Level 0 and Level 3. If the three Eye Amplitudes are equal, the linearity is 1.

When Linearity Definition is IEEE Clause 94:

It is calculated with the smallest eye amplitude out of the three eye amplitudes.

Example:

Eye Amplitude Upper: 33%

Eye Amplitude Middle: 36%

Eye Amplitude Lower: 31%

The Linearity in this case is $\frac{31}{33.33} = 0.93$

When Linearity Definition is IEEE Annex 120D:

Calculate the following values from four levels of PAM4 waveform.

$$V_{mid} = \frac{Level3 + Level0}{2}$$

$$ES1 = \frac{Level1 - V_{mid}}{Level0 - V_{mid}}$$

$$ES2 = \frac{Level2 - V_{mid}}{Level3 - V_{mid}}$$

The minimum of the following values is the Linearity.

$3 * ES1$, $3 * ES2$, $2 - 3 * ES1$, $2 - 3 * ES2$

Example:

Level3: 1.00

Level2: 0.67

Level1: 0.31

Level0: 0.00

$$V_{mid} = (1.00 + 0.00) / 2 = 0.50$$

$$ES1 = (0.31 - 0.50) / (0.00 - 0.50) = 0.38$$

$$ES2 = (0.67 - 0.50) / (1.00 - 0.50) = 0.34$$

$$3 * ES1 = 1.14, 3 * ES2 = 1.02$$

$$2 - 3 * ES1 = 0.86, 2 - 3 * ES2 = 0.98$$

The Linearity in this case is 0.86.

Mask Margin

This is the margin between the waveform and the eye mask in mask test of eye pattern. The margin in the amplitude direction is the ratio to the interval from the edge of the eye mask to the 1 Level or the 0 Level. The margin in the time direction is the ratio to the time from the edge of the eye mask to the cross point.

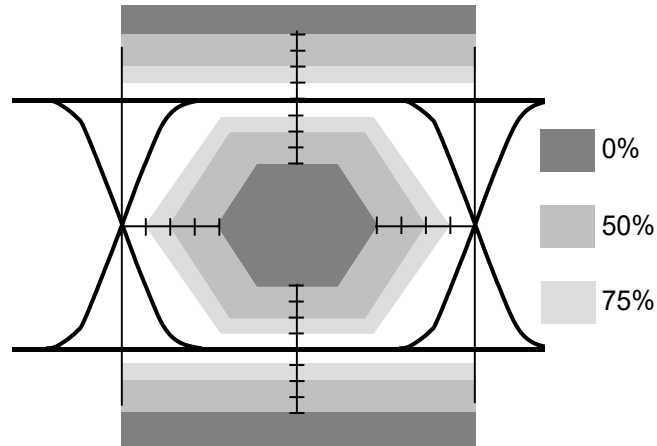

Figure 1.5-20 Mask Margin

Noise Margin

This indicates the noise that can be added until the measured value of the eye opening of the PAM4 signal reaches $SER = 4.8 \times 10^{-4}$.

This is equivalent to R of TDECQ and measured at the same position as TDECQ (Transmitter and Dispersion Eye Closure for PAM4).

Optical Modulation Amplitude (OMA)

This indicates a difference at 1 level and 0 levels of the NRZ waveform.

It is the same as Eye Amplitude.

For PAM4 waveform, refer to “Outer OMA” .

One Level

At Eye pattern measurement, the maximum level at the center 20% of the bit interval is the average value of the high histogram.

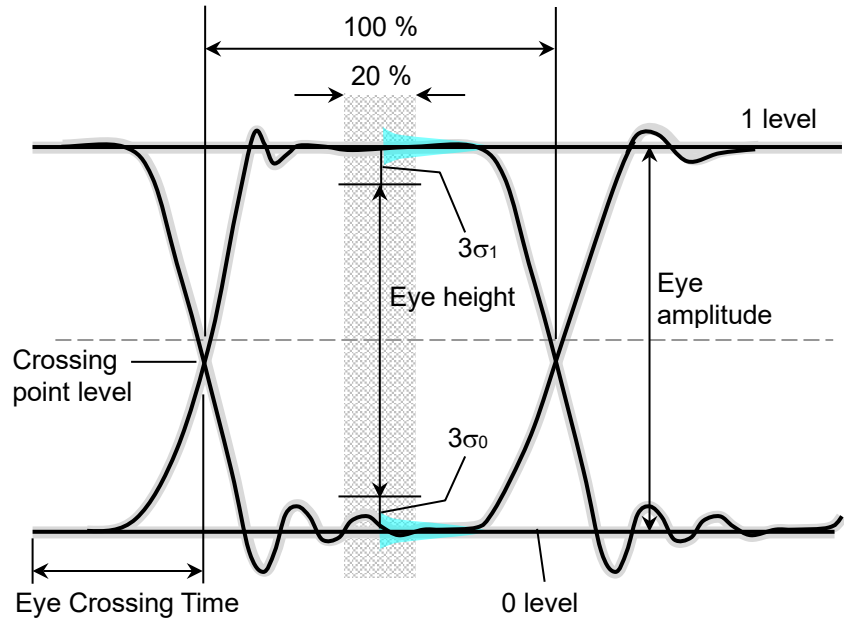

Figure 1.5-21 0 Level, 1 Level, Eye Crossing Time, Eye Amplitude and Eye Height

Outer ExR (Outer Extinction Ratio)

Outer Extinction Ratio is the ratio of Level 3 and Level 0 of the PAM4 waveform, and the calculation formula is as follows.

$$\text{Outer Extinction Ratio} = 10\log_{10}\{(L_3 - L_D) / (L_0 - L_D)\} \quad (\text{dB})$$

L_3 : Level 3 (mW)

L_0 : Level 0 (mW)

L_D : Level when no light input (mW)

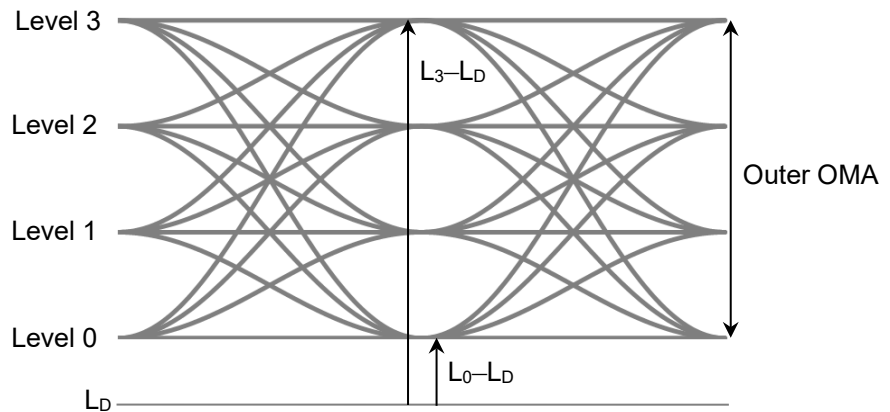

Figure 1.5-22 The Level to Measure Outer Extinction Ratio

Outer OMA

It is the optical modulation amplitude of PAM 4 waveform, and it is the difference between Level 3 and Level 0.

Overshoot

It is the ratio of the maximum power to Level 3 in the PAM4 waveform and is calculated by the following formula:

$$\text{Overshoot} = \frac{P_{\text{max}} - \text{Level 3}}{\text{Outer OMA}} \times 100$$

Pmax: Maximum power measured in the waveform

p-p (peak to peak)

Indicates difference between maximum and minimum values for signal amplitude and data distribution width

For example, Vp-p means the difference between the maximum and minimum values of the AC voltage.

Jitter p-p means the difference between the maximum and minimum values of the jitter time distribution.

Partial Noise Margin

This indicates the noise that can be added until the measured value of the eye opening of the PAM4 signal reaches $\text{SER} = 4.8 \times 10^{-4}$.

This is calculated at the 0.45 UI position and 0.55 UI position for each of three eye openings. Measurement is performed at 6 histograms in the following figure.

Upper/Left, Upper/Right, Middle/Left, Middle/Right,
Lower/Left, Lower/Right

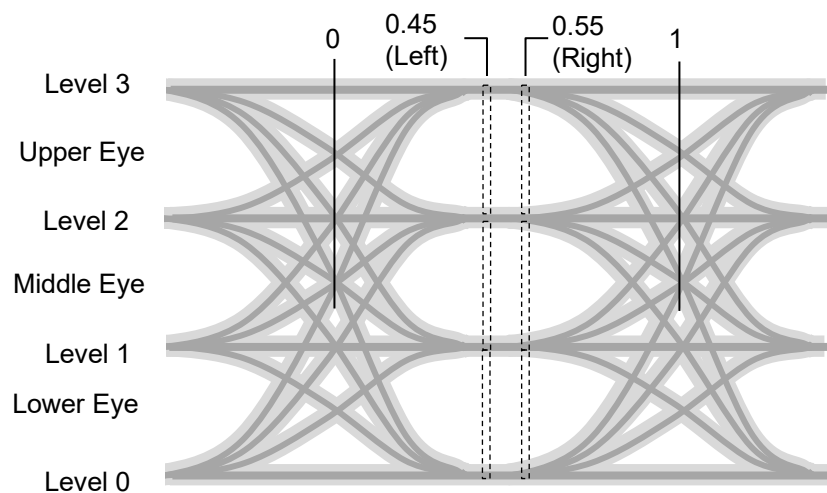

Figure 1.5-23 Partial Noise Margin Measurement Positions

Partial TDECQ

This indicates the measured value of the eye opening of the PAM4 signal and is calculated by the same formula as TDECQ (Transmitter and Dispersion Eye Closure for PAM4).

This is calculated by obtaining the additive noise R at the 0.45 UI position and 0.55 UI position for each of three eye openings. Measurement is performed at 6 points shown in Figure 1.5-23.

Power Excursion

This indicates the larger one of the following two values of the PAM4 waveform.

- Difference between P_{max} and P_{avg}
- Difference between P_{avg} and P_{min}

P_{max} (Maximum power)

Power at the level where the proportion of samples from the highest level becomes 10^{-2}

P_{min} (Minimum power)

Power at the level where the proportion of samples from the lowest level becomes 10^{-2}

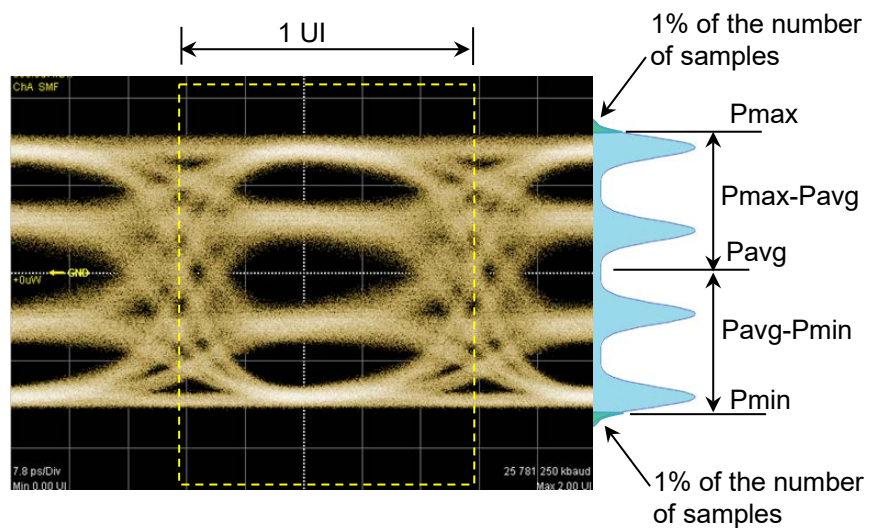

Figure 1.5-24 Power Excursion Measurement Level

PRBS (Pseudo-Random Bit Sequence)

PRBS is the abbreviation for pseudorandom bit sequence. It is a bit string approximating actual communications data with a random distribution of “1” and “0”. In a bit length of 2^n-1 , n is called the number of the PRBS. Using the BERTWave, n can be set to 7, 9, 15, 23, and 31.

Table 1.5-2 PRBS Bit Length

n	2^n-1
7	127
9	511
15	32767
23	8388607
31	2147483647

The number of the PRBS used for measuring the Rx sensitivity is determined by the communications standard.

RIN OMA

RIN OMA is a measurement of the ratio of the light source's noise power to signal power (dB/Hz) based on OMA and is calculated by the following formula.

$$\text{RIN OMA} = 10\log_{10}\left\{\frac{(\text{RN}_{\text{one}}+\text{RN}_{\text{zero}})^2}{\text{OMA}^2 \times \text{BW}}\right\} \text{ (dB/Hz)}$$

- RNone: Electrical random noise power measured at the top level
Use Level 1 for NRZ signals and Level 3 for PAM4 signals.
- RNzero: Electrical random noise power measured at Level 0
- OMA: For NRZ signal, OMA, and for PAM4 signal, Outer OMA.
- BW: Bandwidth of the filter used

Rise/Fall Time

The Rise Time is time taken for the signal level to change to the next level.

- From 20% level of amplitude to 80%
- From 10% level of amplitude to 90%

The Fall Time is the time taken for the signal level to change to the next level.

- From 80% level of amplitude to 20%
- From 90% level of amplitude to 10%

For the MP2110A, the rise and fall time measurement level can be selected from either 10/90% or 20/80%.

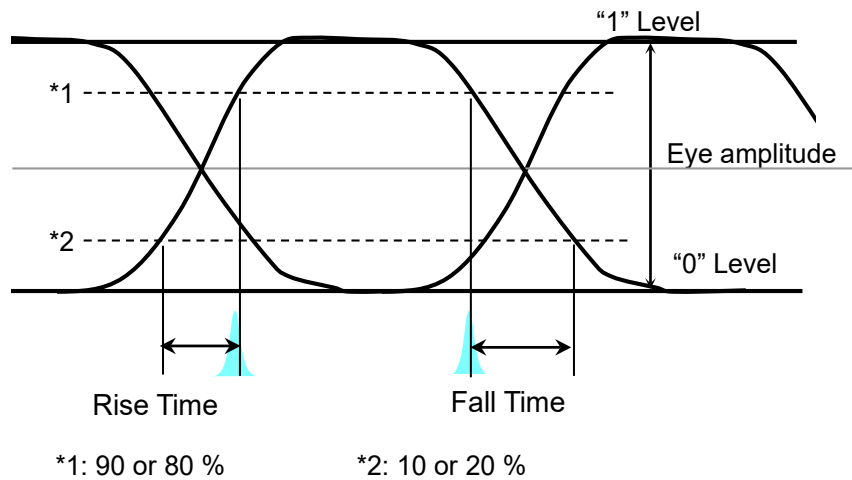

Figure 1.5-25 Rise and Fall Time

RMS (root mean square)

This is the DC voltage consuming the equal power the same as the consumed power when impressing AC voltage on a resistance.

In Voltage, RMS is DC voltage consuming the equal power when AC voltage is impressing on a resistance.

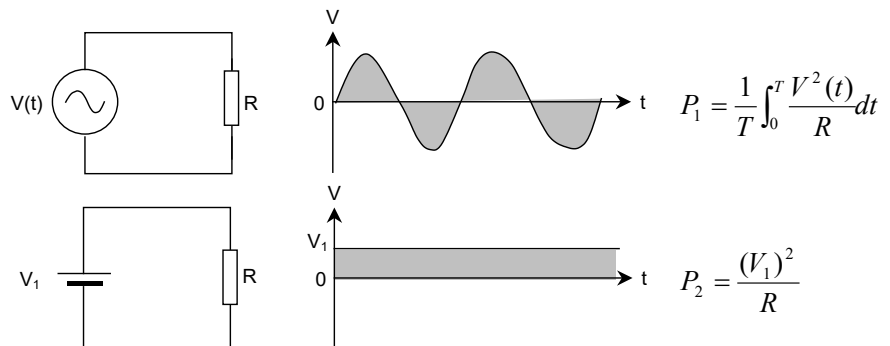

Figure 1.5-26 AC and DC Voltage Power Consumption

In the circuit in Figure 1.5-26, the voltage V_1 when the power P_1 and P_2 consumed by resistance R is equal is the effective AC voltage $V(t)$. V_1 is the root mean square found using the following equation.

$$V_1 = \sqrt{\frac{1}{T} \int_0^T V^2(t) dt}$$

For a sine wave, the ratio of RMS and p-p is $2\sqrt{2}$.

Vrms means the effective voltage value.

Jitter rms is expressed as the standard deviation of the jitter time domain histogram.

Sampling Oscilloscope

The sampling oscilloscope is a function for monitoring the waveform of the input signal. It requires a clock input sampling and the waveform is drawn out of the clock timing. For a periodic signal like PRBS, the waveform data is obtained by slightly varying the sampling timing. This waveform data is drawn by superimposing the waveforms.

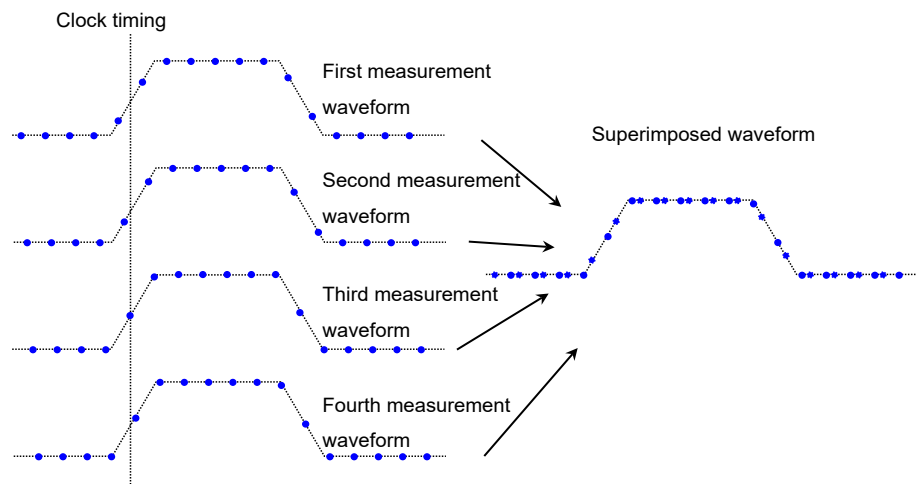

Figure 1.5-27 Drawing Method of Sampling Oscilloscope

SNR (Signal to Noise Ratio)

This is the ratio of the signal amplitude to the noise amplitude. The sampling oscilloscope can be calculated by the following formula.

$$\text{SNR} = (1 \text{ Level} - 0 \text{ Level}) / (\sigma_1 + \sigma_0)$$

σ_1 : 1 Level Standard Deviation

σ_0 : 0 Level Standard Deviation

Symbol Rate

Symbol rate is the modulation speed of the signal and the unit is baud. As one NRZ modulated signal (symbol) carries 1 bit of data, the Symbol Rate value is the same as Bit Rate. As one PAM4 modulated signal carries 2 bits of data, the Bit Rate value is the twice of Symbol Rate.

TDEC (Transmitter and Dispersion Eye Closure)

TDEC is the measured value of the eye opening of the NRZ signal and is calculated by the following formula.

For details, refer to 95.8.5.2 “TDEC measurement method” of the IEEE 802.3.

$$\text{TDEC} = 10\log_{10}\left(\frac{\text{OMA}}{2} \times \frac{1}{3.8906R}\right) \text{ (dB)}$$

R: Noise added at the receiver

It is obtained from the measured results indicated by square-dot histogram in the figure below.

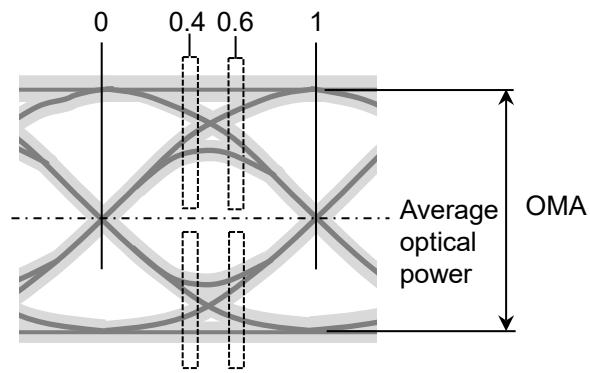

Figure 1.5-28 The Position for TDEC Measurement

TDECQ (Transmitter and Dispersion Eye Closure for PAM4)

TDECQ is the measured value of the eye opening of the PAM4 signal and is calculated by the following formula.

$$\text{TDECQ} = 10 \log_{10} \left(\frac{\text{Outer OMA}}{6} \times \frac{1}{Q_t R} \right) \text{ (dB)}$$

Q_t : 3.414 where SER (Symbol Error Rate) = 4.8×10^{-4} (as specified in the IEEE 802.3cd)

R : Additional noise necessary to make SER = 4.8×10^{-4}

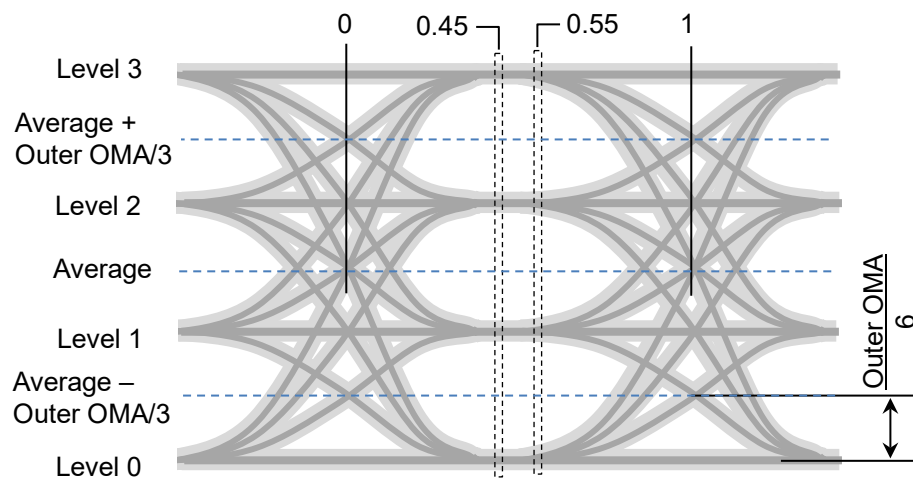

Figure 1.5-29 The Position for TDECQ Measurement

Total Error

There are two methods as follows for generating bit errors.

The following bit error count corresponding to the sum of Insertion Error and Omission Error is referred to as the Total Error.

- Signal “1” bits evaluated as “0” bits (Omission Error)
- Signal “0” bits evaluated as “1” bits (Insertion Error)

Transition Time

It is the time required to transit from 20% to 80% between Level 0 and Level 3 in the PAM4 waveform, and is measured at the position where Level 0 and Level 3 continue for 5 symbols or more. Rise (rise time), Fall (fall time), and Slowest (Rise or Fall, whichever is slower) can be measured.

Undershoot

It is the ratio of the minimum power to Level 0 in the PAM4 waveform and is calculated by the following formula:

$$\text{Undershoot} = \frac{\text{Level 0} - P_{\min}}{\text{Outer OMA}} \times 100$$

P_{\min} : Minimum power measured in the waveform

VECP (Vertical Eye Closure Penalty)

VECP is the ratio of eye amplitude to eye opening and is calculated by the following formula.

$$\text{VECP} = 10 \log\left(\frac{\text{OMA}}{A_0}\right) \text{ (dB)}$$

OMA: Optical Modulation Amplitude

A_0 : Vertical Eye Opening

The histogram is measured at the center point between the cross points on the time axis. (OMA)

The upper and lower limits of the vertical eye opening are measured. (A_0)

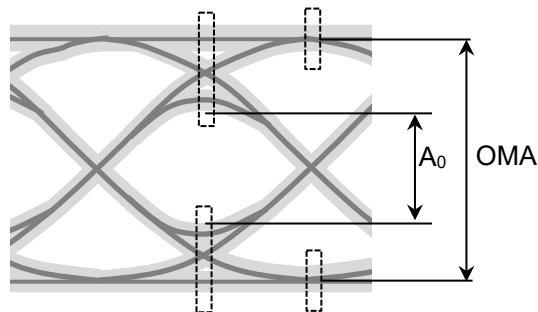

Figure 1.5-30 VECP Measurement

VMA (Voltage Modulation Amplitude)

This is the difference between Level 1 and Level 0 of NRZ waveform in electrical measurement.

This is the same as eye amplitude.

For PAM4 waveform, the difference between Level 3 and Level 0 of modulation amplitude.

Zero Level

At Eye pattern measurement, the maximum level at the center 20% of the bit interval is the average value of the low histogram.

1.6 Abbreviations

The abbreviations used in this manual are listed in Table 1.6-1.

Table 1.6-1 Abbreviation

Abbreviation	Description
100GbE	100 Giga bit Ethernet
400GbE	400 Giga bit Ethernet
App	Application
ATT	Attenuator
Avg	Average
BER	Bit Error Rate
BERT	Bit Error Rate Tester
BERTS	Bit Error Rate Test Set
BIN	Binary
bps	bit per second
BW	Bandwidth
Cal	Calibration
CC	Clock Count
CFP	C Form factor Pluggable
Ch	Channel
CH	Channel
Clk	Clock
CPRI	Common Public Radio Interface
CRU	Clock Recovery Unit
DCD	Duty Cycle Distortion
DDJ	Data Dependent Jitter
DDPWS	Data Dependant Pulse Width Shrinkage
DJ	Deterministic Jitter
DM	Degrade Minutes
DMUX	De-multiplexer
DUT	Device Under Test
EC	Error Count
ED	Error Detector
EDR	Enhanced Data Rate
EI	Error Interval
ER	Error Rate
ER	Extinction Ratio
ES	Error Seconds
ESD	Electrostatic Discharge
ExR	Extinction Ratio
Ext	External
FC	Fibre Channel
FDR	Fourteen Data Rate
FEC	Forward Error Correction
Freq.	Frequency

Table 1.6-1 Abbreviation (Cont'd)

Abbreviation	Description
GND	Ground
GPIB	General Purpose Interface Bus
IEC	International Electrotechnical Commission
In	Input
INS	Insertion
INT	Internal
ISI	Inter Symbol Interference
ITU	International Telecommunication Union
LAN	Local Area Network
Max	Maximum
MDIO	Management Data Input/Output
MMF	Multi-mode fiber
MUX	Multiplexer
NA	Not Applied
NECL	Negative Emitter Coupled Logic
NEG	Negative
NRZ	Non Return Zero
O/E	Optical to Electrical converter
OMA	Optical Modulation Amplitude
OMI	Omission
OTU	Optical Transport Unit
Out	Output
PAM	Pulse Amplitude Modulation
PCML	Positive Current Mode Logic
PDF	Probability Density Function
PDJ	Pattern Dependant Jitter
PHY	Physical layer
PJ	Periodic Jitter
POS	Positive
p-p	Peak to peak
PPG	Pulse Pattern Generator
PRBS	Pseudorandom Bit Sequence
Pwr	Power
QSFP	Quad Small Form factor Pluggable
RJ	Random Jitter
RMS	Root Mean Square
rms	Root Mean Square
RX	Receiver
SCFL	Source-Coupled FET Logic
SER	Symbol Error Rate
SES	Severely Error Second
SJ	Sinusoidal Jitter
SMF	Single-mode fiber

Table 1.6-1 Abbreviation (Cont'd)

Abbreviation	Description
SNR	Signal to Noise Ratio
SSPRQ	Short Stress Pattern Random Quaternary
STM	Synchronous Transfer Mode
SYNC	Synchronize, Synchronization
TDEC	Transmitter and Dispersion Eye Closure
TDECQ	Transmitter and Dispersion Eye Closure for PAM4
TJ	Total Jitter
Trig.	Trigger
TX	Transmitter
UI	Unit Interval
VECP	Vertical Eye Closure Penalty
VMA	Voltage Modulation Amplitude
WAN	Wide Area Network
XData	<u>Data</u>

Chapter 2 Before Use

This chapter explains the following items:

- Procedures from unpacking through turning power-on
- Panel name and operation
- Control panel and peripheral devices settings
- Damage prevention measures

2.1	Unpacking and Installation.....	2-2
2.1.1	Unpacking.....	2-2
2.1.2	Installation	2-2
2.2	Part Names	2-5
2.2.1	Front Panel	2-5
2.2.2	Rear Panel.....	2-12
2.3	Power Connection	2-13
2.3.1	Power Requirements.....	2-13
2.3.2	Connecting Power Cord	2-14
2.4	Connecting Peripheral Devices	2-15
2.5	Connecting Remote Control Devices	2-16
2.6	Cautions on Handling Optical Fiber Cables.....	2-18
2.7	Connecting Coaxial Cable	2-20
2.7.1	Notes on Coaxial Cable Connection	2-20
2.7.2	How to Discharge the Electrostatic Charges of the Coaxial Cable	2-21
2.8	Turning Power On/Off.....	2-22
2.8.1	Power-on	2-22
2.8.2	Power-off	2-23
2.9	Setting Control Panel.....	2-24
2.9.1	Displaying Windows Desktop	2-24
2.9.2	Setting Control Panel.....	2-25
2.9.3	Setting External Monitor	2-26
2.10	Precautions for Preventing Damage.....	2-30
2.10.1	Precautions on Electrostatic Discharge and Electrical Overstress	2-32
2.10.2	Precautions When Using Bias-T	2-36
2.11	Windows Security Measures	2-38
2.11.1	Activating Firewall.....	2-39
2.11.2	Installing Windows Important Update Programs (Windows Update).....	2-50
2.11.3	Using Antivirus Software	2-54

2.1 Unpacking and Installation

2.1.1 Unpacking

At unpacking, check that all items are included. Contact an Anritsu Service and Sales office if any parts are missing or damaged. Keep the original packaging materials. They are required when transporting the BERTWave in future.

For repacking the MP2110A, refer to 8.9, “Transporting and Disposal”.

The options listed in Table 1.2.2-1 are provided for the MP2110A. Verify that the options purchased are installed.

To install some options, the MP2110A might be returned to Anritsu factory. For the specifications, refer to Appendix A “Specifications”.

2.1.2 Installation

Install the BERTWave horizontally as shown in Figure 2.1.2-1.

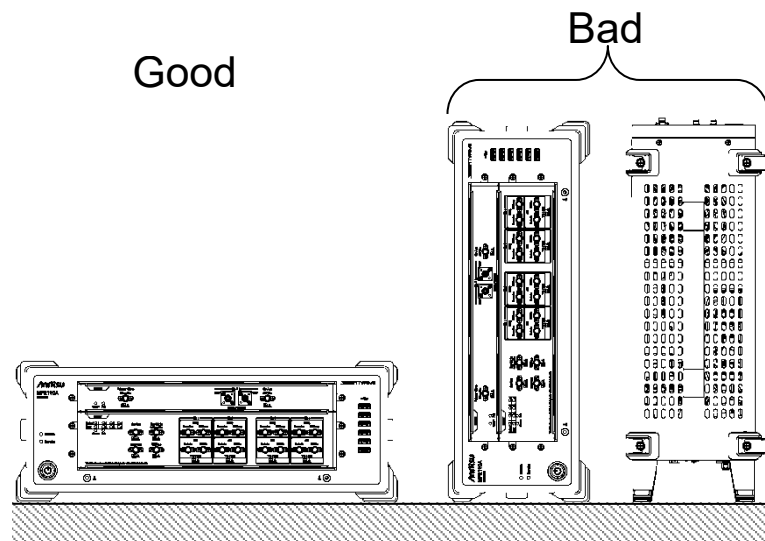

Figure 2.1.2-1 Installation Orientation

⚠ CAUTION

- If the MP2110A is not installed in a “good” direction as above, a small shock may turn it over and harm the user.
- Do not stack three or more MP2110As on top of each other when using them. There is a risk of injury, because stacked MP2110As are unstable and can fall due to vibration or shock.

2

Before Use

The withstand load of the MP2110A top panel is 10 kg. When placing a monitor and other equipment on the MP2110A, the total weight of the placed equipment should not exceed 10 kg. Fix the monitor, etc. on MP2110A to avoid falling it down from the top panel due to vibration or shock.

A fan is installed in the MP2110A to prevent the internal temperature from rising. Install the MP2110A in a location with the vents at least 10 cm away from walls, peripherals or other obstructions so as not to block the fan perimeter.

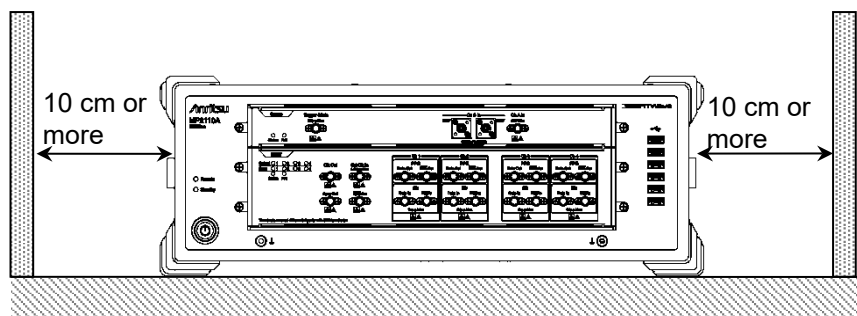

Figure 2.1.2-2 Distance from Surrounding Objects

The MP2110A takes in cooling air from the left side panel and exhausts it from the right side panel. When using two or more the MP2110A units side-by-side, make sure that hot air exhausted from one unit is not taken into the adjacent unit, otherwise overheating may occur.

⚠ WARNING

Do not insert any metal object like, such as tweezers or a screwdriver, into vents on the side panels. Failure to do so can cause electric shock.

 **CAUTION**

Although the MP2110A operates at an ambient temperature of 5 to 40°C, avoid using it in locations, such as the following, since it may cause failure.

- In direct sunlight for extended periods
 - Outdoors
 - In excessively dusty locations
 - In liquids, such as water, oil, organic solvents, and medical fluids, or places where these liquids may adhere
 - In salty air or where chemically active gases (sulfur dioxide, hydrogen sulfide, chlorine, ammonia, nitrogen oxide, or hydrogen chloride etc.) are present
 - Where toppling over may occur
 - Where static electric charges or high electromagnetic fields are present
 - Where abnormal power voltages (high or low) occur
 - In the presence of lubricating oil mists
 - Where condensation occurs
 - In places at an altitude of more than 2,000 m
 - In the presence of frequent vibration and mechanical shock, such as in cars, ships, and airplanes
-

2.2 Part Names

2.2.1 Front Panel

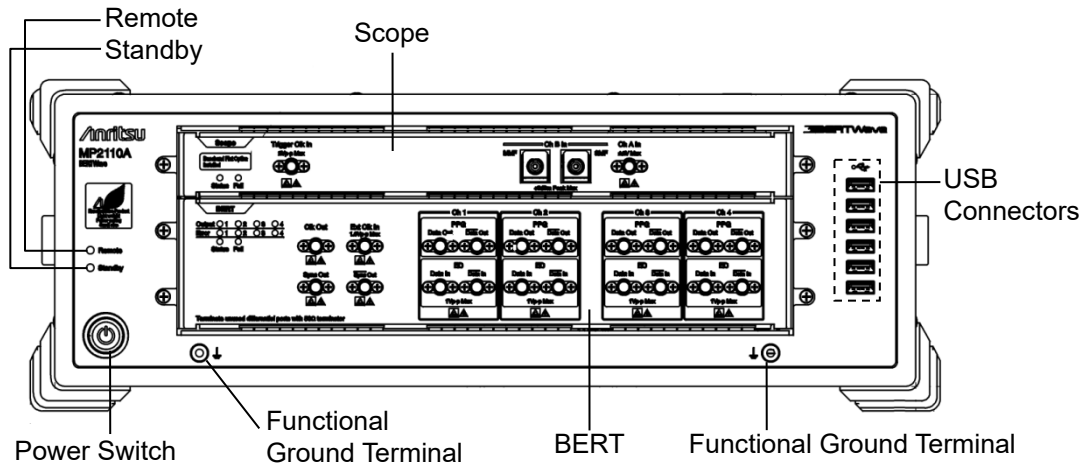

Figure 2.2.1-1 Front Panel (Scope+BERT)

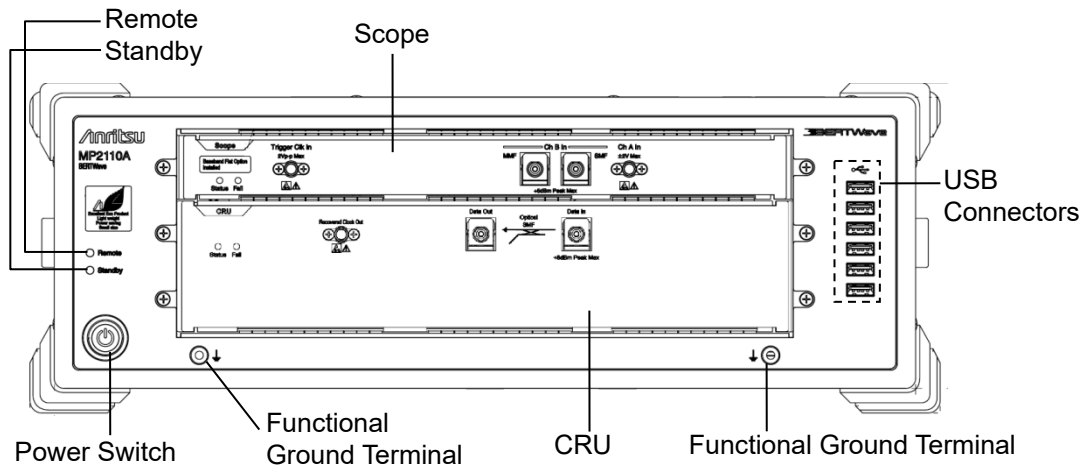
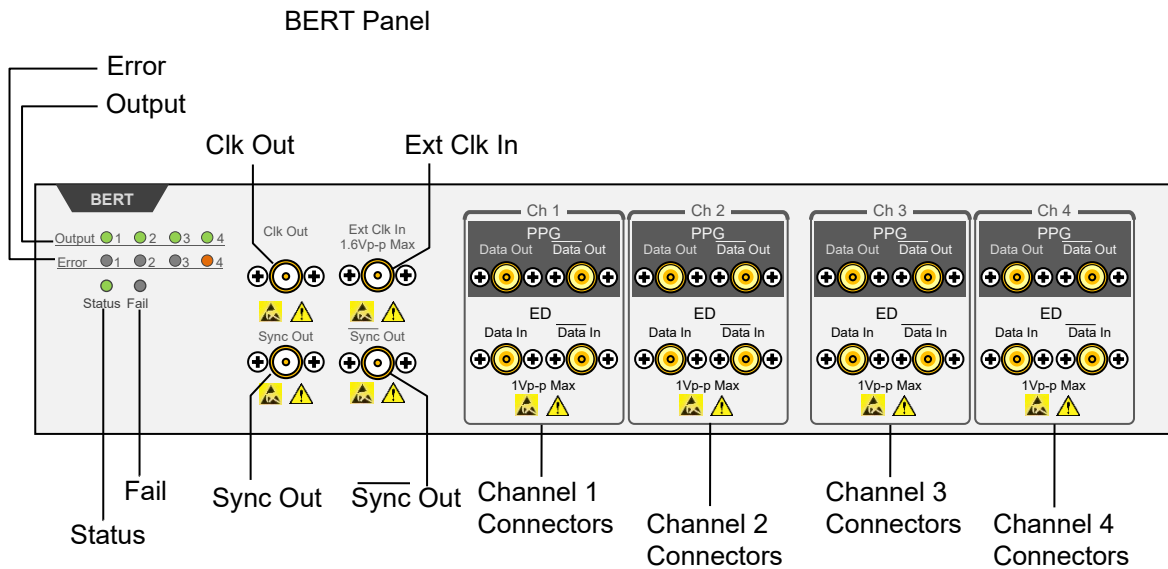

Figure 2.2.1-2 Front Panel (Scope+CRU)

Table 2.2.1-1 Front Panel Description

Name	Description
Scope	Panel of the sampling oscilloscope If no scope option is installed, this slot is filled with a blank panel.
BERT	Panel of the bit error rate tester If neither BERT option nor MP2110A-x55 is installed, this slot is filled with a blank panel.
CRU	Panel of the clock recovery unit If neither BERT option nor MP2110A-x55 is installed, this slot is filled with a blank panel.
Remote	Lights in green when MP2110A is under remote control.
Standby	Lights in orange when power is supplied to MP2110A.
Power Switch	Lights in green when MP2110A is powered-on. Flashes while shutting down MP2110A.
Functional Ground Terminal	Ground terminal For connecting wrist strap, ESD Discharger, or DUT.
USB Connector	USB 2.0 connectors for connecting peripheral accessories including mouse and keyboard.



2

Before Use

Figure 2.2.1-3 BERT Panel Names (MP2110A-x14)

The following tables describe the panel.

Table 2.2.1-2 Lamp List

Name	Description
Output	Lit green during signal output from PPG connector.
Error	Lit orange at following condition at ED: - Unable to synchronize pattern (Sync Loss). - Bit error detected.
Status	Lit green during normal operation while able to receive remote commands.
Fail	Lit red when hardware fault detected. This may light briefly at power-on, but there is no abnormality.

Table 2.2.1-3 Connector List

Connector Name	Description	Level Range
Clk Out	Outputs divided clock.	0.3 to 0.5 Vp-p
Ext Clk In	For input of external clock.	0.2 to 1.6 Vp-p
Sync Out	Outputs the clock synchronized to PPG pattern.	V_{OH} : -0.2 to 0.05 V
$\overline{\text{Sync}}$ Out	Outputs the inverted clock synchronized to PPG pattern.	V_{OL} : -1.2 to -0.7 V
$\overline{\text{Data}}$ Out	Outputs the PPG data.	0.1 to 0.8 Vp-p (Variable)*
$\overline{\text{Data}}$ Out	Outputs the PPG inverted data.	
$\overline{\text{Data}}$ In	ED data input.	0.05 to 0.8 Vp-p*
$\overline{\text{Data}}$ In	ED inverted data input.	

*: Same for Ch1 to Ch4.

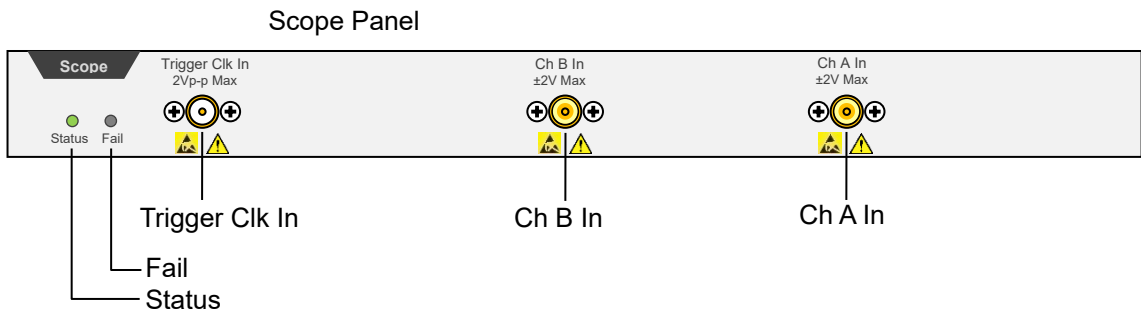

Figure 2.2.1-4 Scope Panel Names (MP2110A-x21)

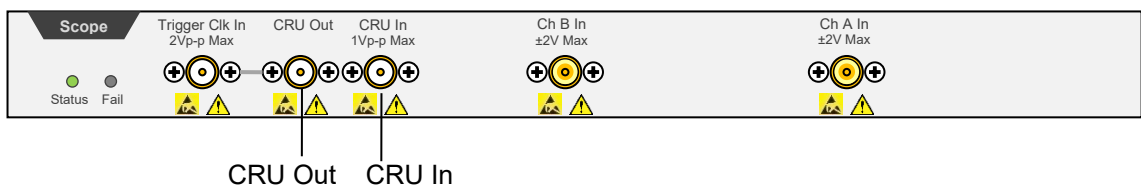

Figure 2.2.1-5 Scope Panel Names (with MP2110A-x21 and MP2110A-x54)

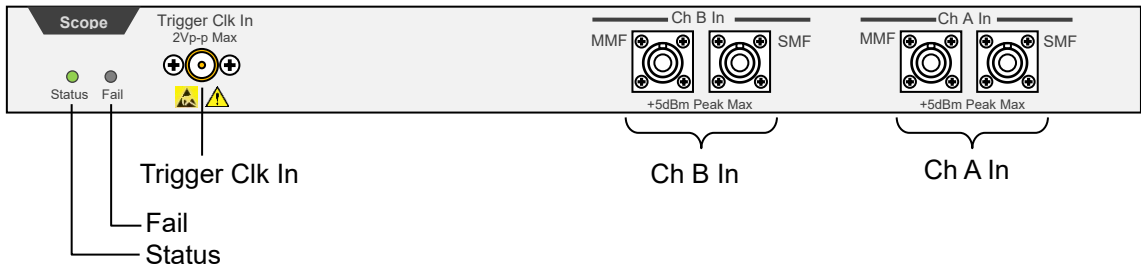

Figure 2.2.1-6 Scope Panel Names (MP2110A-x22)

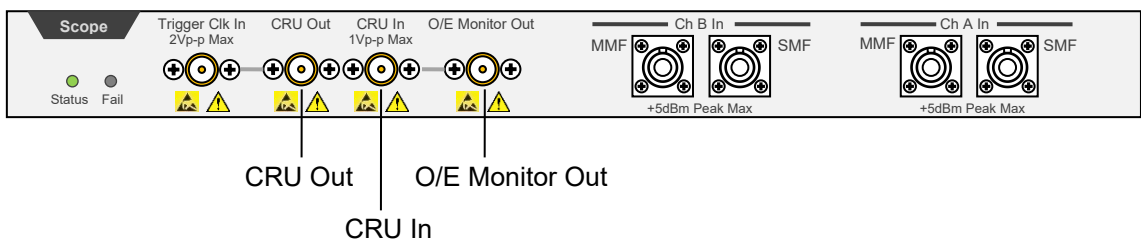

Figure 2.2.1-7 Scope Panel Names (with MP2110A-x22 and MP2110A-x54)

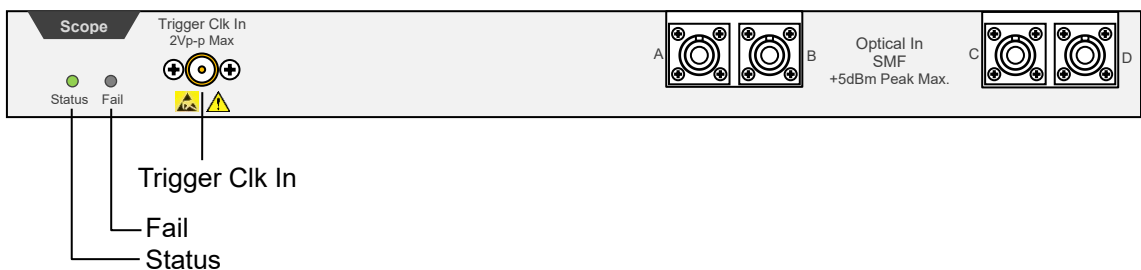

Figure 2.2.1-8 Scope Panel Names (MP2110A-x40)

The following label is on the panel of MP2110A-x30, MP2110A-x32, MP2110A-x33, MP2110A-x35, MP2110A-x36, and MP2110A-x39.

Baseband Flat Option
Installed

The following tables describe the panel.

Table 2.2.1-4 Lamp List

Name	Description
Status	<p>Lights when MP2110A can receive remote commands upon successful start. The color indicates the trigger clock input status.</p> <p>Green: The trigger clock is detected.</p> <p>Red: The trigger clock is not detected. Check that the signal is input to the trigger clock input connector.</p> <p>Orange: The trigger clock signal input is detected but is out of the frequency range.*</p>
Fail	<p>Lights in red when a hardware fault is detected at startup. The lamp may light in short time when turning on and off the power, but this is not an error.</p>

- *: Check the following items when the Status lamp is lit in orange. Refer to Section 6.2.6, “Time CRU Dialog Box”, for the operation method.
- Specify the input trigger clock in the range from 0.1 to 15.0 GHz. (When **ON** is specified at Precision Trigger, specify 2.4 GHz or more.)
 - When **Off** is specified at Tracking in Time dialog box, match the Clock Rate setting value and the actual trigger clock frequency by one of the following methods.
 - Change the Clock Rate setting value to the actual trigger clock frequency.
 - Execute Acquire Clock Rate.
 - When **PPG** is specified at Tracking in Time dialog box, specify the trigger clock frequency within the range defined by PPG's Bit Rate and Divide Ratio.
 - When **CRU** is specified at Tracking in Time dialog box, check CRU In input signal and CRU setting in Time dialog box to turn Lock Status green.

Table 2.2.1-5 Connector List

Connector Name	Description	Maximum Input Level
Trigger Clk In	For trigger clock input to the sampling oscilloscope.	2 Vp-p
Ch A In*1	Data input SMF: 860 to 1650 nm MMF: 800 to 860 nm	Coaxial connector: ±2 V SMF optical connector: +8 dBm peak MMF optical connector: +10 dBm peak
A*2	SMF: 1260 to 1650 nm MMF: 800 to 860 nm	SMF optical connector: +8 dBm peak MMF optical connector: +10 dBm peak
Ch B In*1	Data input SMF: 860 to 1650 nm MMF: 800 to 860 nm	Coaxial connector: ±2 V SMF optical connector: +8 dBm peak MMF optical connector: +10 dBm peak
B*2	SMF: 1260 to 1650 nm MMF: 800 to 860 nm	SMF optical connector: +8 dBm peak MMF optical connector: +10 dBm peak
C*2	SMF: 1260 to 1650 nm MMF: 800 to 860 nm	SMF optical connector: +8 dBm peak MMF optical connector: +10 dBm peak
D*2	SMF: 1260 to 1650 nm MMF: 800 to 860 nm	SMF optical connector: +8 dBm peak MMF optical connector: +10 dBm peak
O/E Monitor Out*3,*4	O/E monitor output	
CRU In*3	Clock recovery unit input	1 Vp-p
CRU Out*3	Clock recovery unit output	

*1: When MP2110A-x21, x22, x23, x25, x26, x32, x33, x35, x36, x42, x43, x45, or x46 is installed.

*2: When MP2110A-x30, x39, x40, or x49 is installed.

*3: When MP2110A-x54 is installed.

*4: When MP2110A-x22, x23, x25, x26, x30, x32, x33, x35, x36, x39, x40, x42, x43, x45, x46, or x49 is installed.

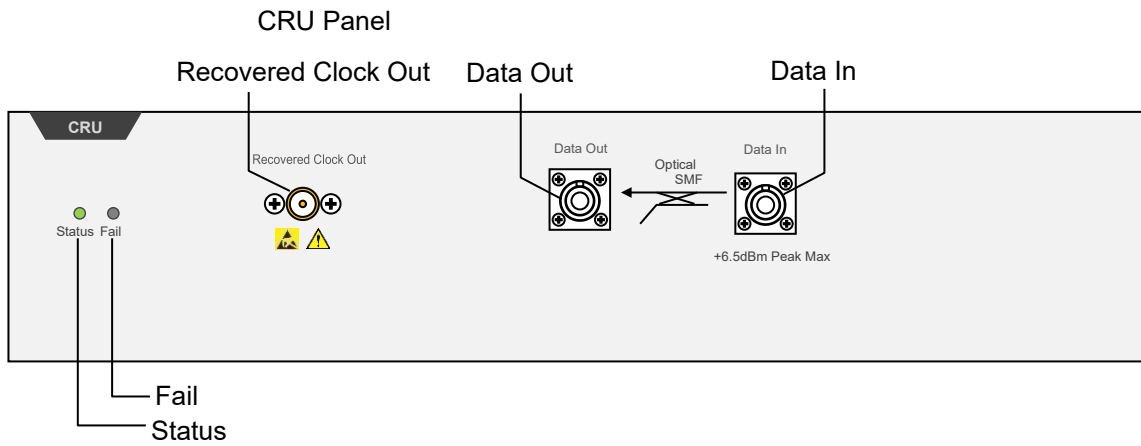

Figure 2.2.1-9 CRU Panel Names (MP2110A-x55)

The following tables describe the panel.

Table 2.2.1-6 Lamp List

Name	Description
Status	Lights when MP2110A can receive remote commands upon successful start. The color indicates the clock recovery status. Green: The clock is recovered normally. Red: The input signal is not detected. Check that the signal is input to the Data In connector. Orange: The input signal is detected but is out of the frequency range.*
Fail	Lights in red when a hardware error is detected at startup. The lamp may light in short time when turning on and off the power, but this is not an error.

*: Check the following item when the Status lamp is lit in orange. Refer to Section 6.2.6, “Time CRU Dialog Box”, for the operation method.

- Set the operation rate according to the signal input to the **Optical SMF Data In** connector.

Table 2.2.1-7 Connector List

Connector Name	Description	Maximum Input Level
Optical SMF Data In	Clock recovery unit optical input Range: 1260 to 1620 nm	+12 dBm peak
Optical SMF Data Out	Clock recovery unit optical output	
Recovered Clock Out	Clock recovery unit output	

2.2.2 Rear Panel

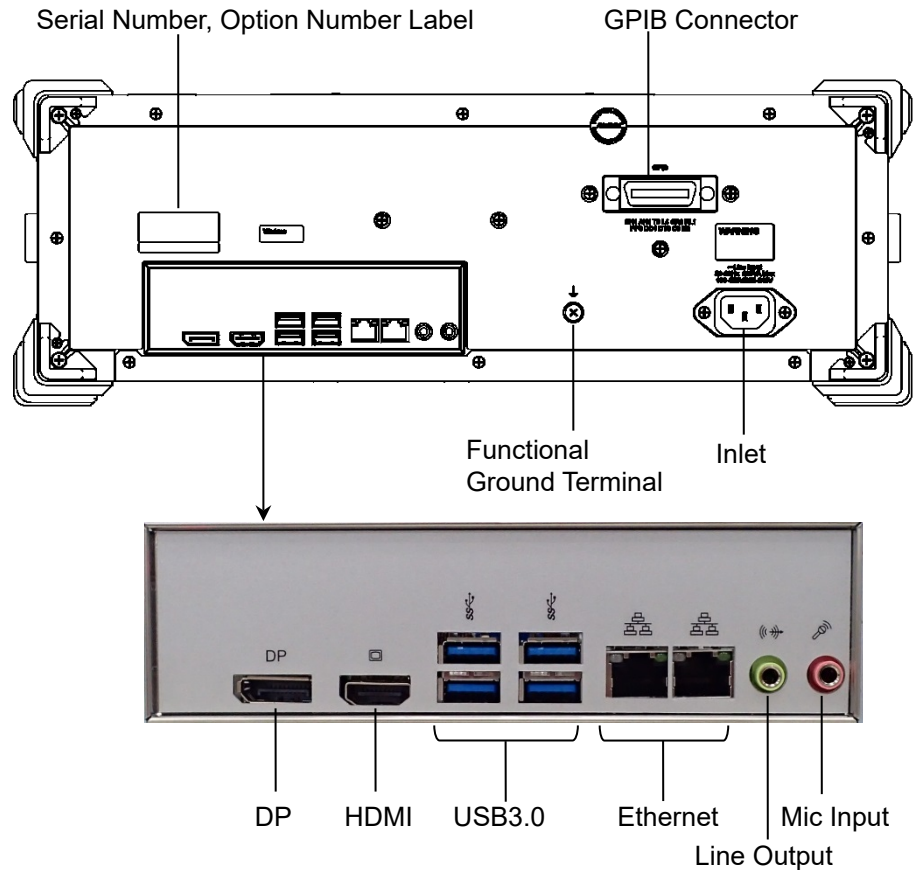

Figure 2.2.2-1 Rear Panel

The following table describes the connectors.

Table 2.2.2-1 Connector List

Name	Description
GPIB	For connecting to a PC to control MP2110A remotely.
DP	For connecting a DisplayPort-compatible external monitor.
HDMI	For connecting an HDMI-compatible external monitor. Refer to 2.4 “Connecting Peripheral Devices”.
USB3.0	For connecting accessories including keyboard and mouse.
Ethernet	For connecting to a PC or network to control MP2110A remotely.
Line Output	This connector is not used.
Mic Input	This connector is not used.
Functional Ground Terminal	Ground terminal For connecting wrist strap or DUT.
Inlet	For connecting the accessory power cord.

2.3 Power Connection

2.3.1 Power Requirements

For normal operation of the MP2110A, use the power voltage range described below.

Table 2.3.1-1 Power Requirements

Power source	Voltage range	Frequency
100 Vac system	100 to 120 V	50 to 60 Hz
200 Vac system	200 to 240 V	50 to 60 Hz

Operating voltage: within the range of +10% to -15% from the rated voltage (Max. AC 250 V).

Switching between 100 and 200 V systems is automatic.



CAUTION

Supplying power exceeding the above range may result in electrical shock, fire, failure, or malfunction.

2.3.2 Connecting Power Cord

Insert the power plug into an outlet, and connect the other end to the power inlet on the rear panel. To ensure that the MP2110A is properly grounded, always use the supplied 3-pin power cord.

WARNING

Always connect the MP2110A to a properly grounded outlet. Do not use the instrument with an extension cord or transformer that does not have a ground wire.

If the MP2110A is connected to an ungrounded outlet, there is a risk of receiving a fatal electric shock. In addition, the peripheral devices connected to the MP2110A may be damaged.

Unless otherwise specified, the signal-connector ground terminal, like an external conductor of the coaxial connector, of the MP2110A is properly grounded when connecting the power cord to a grounded outlet. Connect the ground terminal of DUT to a ground having the same potential before connecting with the MP2110A. Failure to do so may result in an electric shock, fire, failure, or malfunction.

CAUTION

If an emergency arises causing the MP2110A to fail or malfunction, disconnect the MP2110A from the power supply by disconnecting either end of the power cord.

2.4 Connecting Peripheral Devices

USB devices

Connect a mouse, keyboard, storage and other USB devices to the USB connectors on the front or rear panel.

External Monitor

Connect an external monitor to the DP or HDMI connector on the rear-side panel.

Available monitor is:

- Connection via either HDMI or Display Port

When connecting to an external monitor with the VGA connector, use the HDMI to VGA conversion adapter.

- Resolution 1280 × 800 or greater

If the resolution of the display is less than 1280 × 800, the entire application window will not be displayed. If the resolution is 1280 × 800, you can prevent the application window from disappearing by fixing the operation screen to the upper left with **Dock/Undock** on the System Menu. (Refer to 2.9.3 “Setting External Monitor”).

2.5 Connecting Remote Control Devices

Refer to 4.3.10, “Remote Control” for details of how to set the remote control interface.

Ethernet

Connect an Ethernet cable that is CAT 5 cable or newer to the Ethernet connector on the rear panel.

GPIB

Connect the cable to the rear-panel GPIB connector.

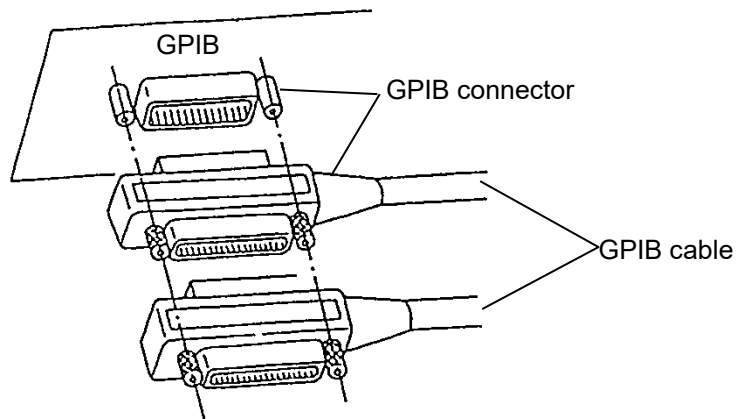

Total cable length:	Up to 20 m
Cable length between devices:	Up to 4 m
Number of devices that can be connected:	Up to 15

Figure 2.5-1 GPIB Cable Connection 1

Connect cables without forming loops.

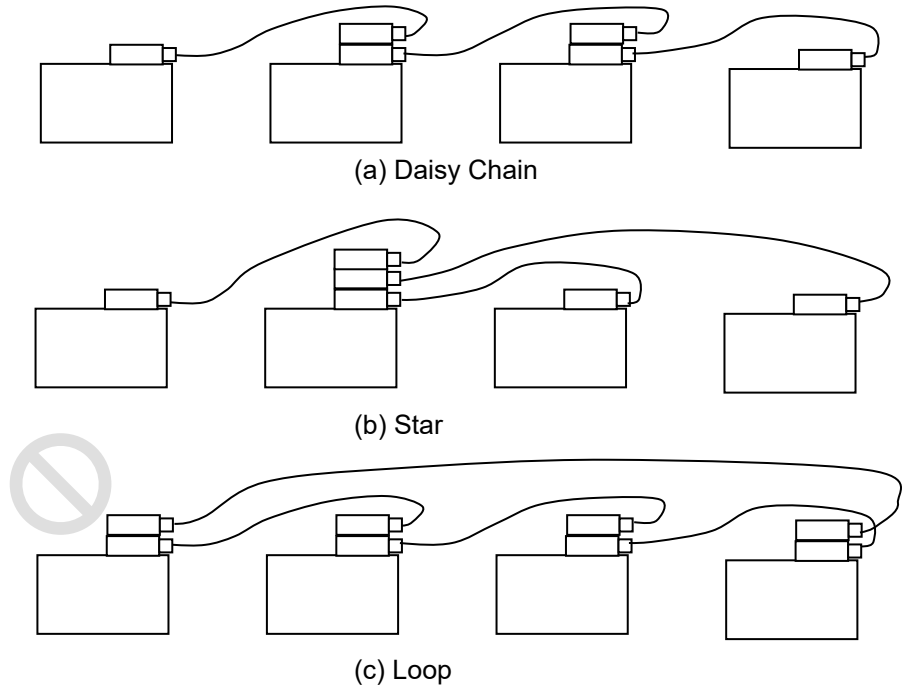

Figure 2.5-2 GPIB Cable Connection 2

2

Before Use

2.6 Cautions on Handling Optical Fiber Cables

Optical fiber cables may degrade in performance or be damaged if handled improperly.

Note the following points when handling them.

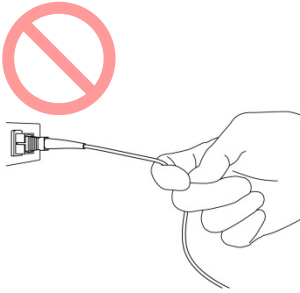

 **CAUTION**

Do not pull the cable when removing the connector.

Doing so may break the optical fiber inside the cable, or remove the cable sheath from the optical connector.

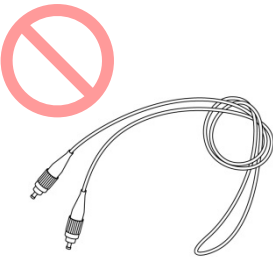

 **CAUTION**

Do not excessively bend, fold, or pinch an optical fiber cable.

Doing so may break the optical fiber inside the cable. Keep the bend radius of an optical fiber cable at 30 mm or more. If the radius is less, optical fiber cable loss will increase.

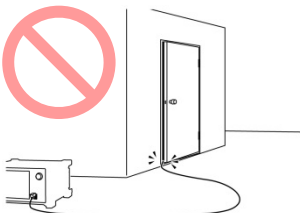
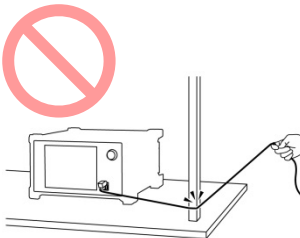



⚠ CAUTION

Do not excessively pull on or twist an optical fiber cable.

Also, do not hang anything by using a cable. Doing so may break the optical fiber inside the cable.

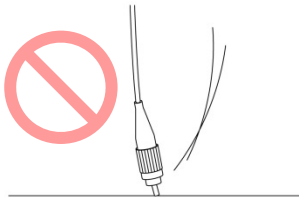

⚠ CAUTION

Be careful not to hit the end of an optical connector against anything hard such as the floor or a desk by dropping the optical fiber cable.

Doing so may damage the connector end and increase connection loss.

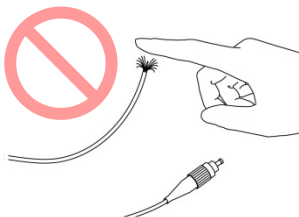

⚠ WARNING

Do not Click the end of a broken optical fiber cable.

The broken optical fiber may pierce the skin, causing injury.

⚠ CAUTION

Do not disassemble optical connectors.

Doing so may cause part to break or the performance to degrade.

2.7 Connecting Coaxial Cable

Connect the coaxial cable to the MP2110A coaxial connector. Refer to 2.10 “Precautions for Preventing Damage”.

2.7.1 Notes on Coaxial Cable Connection

WARNING

When signals are input to the MP2110A, avoid excessive voltage beyond the rating. Otherwise, the circuit may be damaged.

- When output is used at the 50 Ω /GND terminator, never feed any current or input signals to the output.
- Use the correct coaxial cable for connecting to the coaxial connectors of the MP2110A, which are either SMA or K connectors. If the wrong coaxial cable for the connector is used, there is a risk of damage to the connector.
- Tighten coaxial connectors to the correct torque (0.9 Nm). If the coaxial connector is over tightened, there is a risk of damage to the connector, which may prevent disconnection. If the connector is not sufficiently tightened, correct measurement may be impossible.
- When operating the MP2110A with other equipment, arrange so that the co-axial cables are not accidentally pulled; if they are pulled accidentally, the MP2110A may be dragged off the bench top and damaged.
- Always use a coaxial cable with sufficiently low loss matching the signal to be measured. Correct measurement may be impossible if the cable loss is too large.
- Use a coaxial cable with an impedance of 50 Ω . Correct measurement may be impossible if the impedance is incorrect.
- Keep the protective caps fitted to unused coaxial connector.

2.7.2 How to Discharge the Electrostatic Charges of the Coaxial Cable

There is a risk of damaging MP2110A if the coaxial cable you connect to MP2110A is charged electrostatically.

To prevent MP2110A from being damaged by ESD, discharge the electrostatic charges of the coaxial cable by using the ESD Discharger, which is an optional accessory of MP2110A, before cabling the connectors. The ESD Discharger can be used with one of SMA connector, K connector, and V connector (and its compatible connector).

2

Before Use

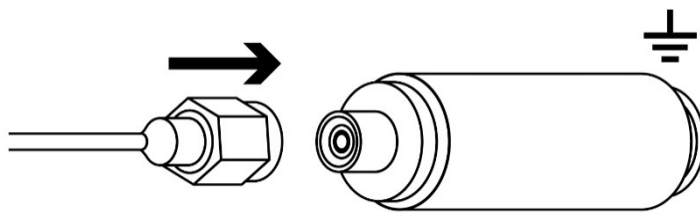

Figure 2.7.2-1 How to Use the ESD Discharger

2.8 Turning Power On/Off

2.8.1 Power-on

1. Before turning power on, connect an external monitor, a keyboard and a mouse to MP2110A. Refer to 2.4 “Connecting Peripheral Devices”.
2. Turn on the external monitor.
3. Connect the power cord plug, referring to 2.3 “Power Connection”. The MP2110A enters the standby state and the Standby lights orange.
4. Press the power switch. The power lamp lights green and the Windows start-up begins.
5. In 30 seconds, the application window is displayed. If the application window is not displayed, refer to 2.9.3 “Setting External Monitor”.

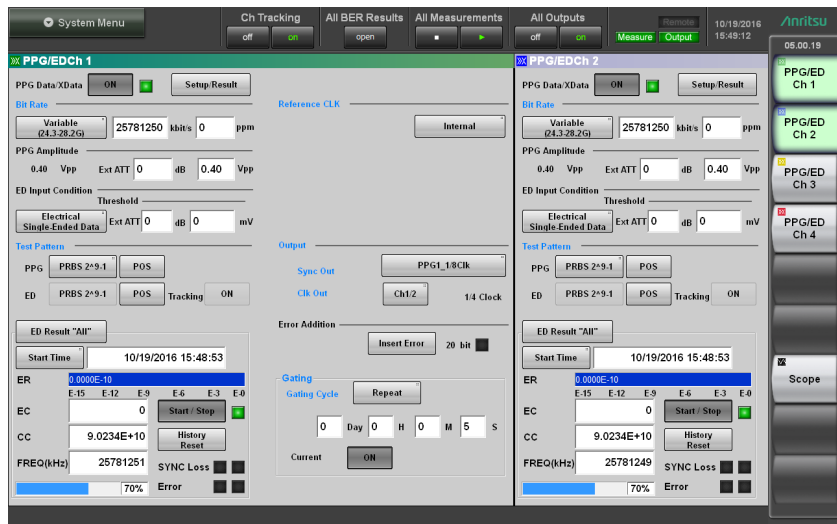

Figure 2.8.1-1 Application Window

Note:

The power of MP2110A can also be turned on by supplying the AC power even if the power button on the panel is not pressed. To perform this operation, select the **On follows AC power** check box in the dialog box displayed by clicking Start Menu - Program - MX210000A - Power Configuration.

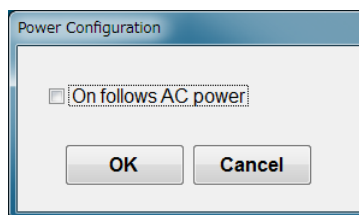

Figure 2.8.1-2 Power Configuration Dialog Box

2.8.2 Power-off

1. Click **System Menu** in the application window.
2. Click **Exit**.
3. Click **Yes**.
4. Press the Power switch.

The Power switch blinks in green. After the power-off process has completed, the power switch lamp goes off, and the Standby lights orange.

Notes:

- If the power plug is removed while the panel access lamp is lit, the data may not be saved correctly. Depending on the type of data that was not saved correctly, sometimes the equipment may not start correctly at the next power-on. Remove the power plug after cutting the power.
- The power may not turn on correctly if the power is turned off and then turned on again immediately after the Standby illuminates orange.
Wait at least 5 seconds after turning off the power before turning on again.

2.9 Setting Control Panel

The MP2110A is set to the factory defaults for optimal measurement. Changing the Windows settings is outside the scope of operation warranty. In addition, the performance may drop or functions may not operate correctly if the Windows settings are changed. Read the general notes in this section carefully when changes to the Windows settings are required.

 **CAUTION**

Anritsu guarantees the MP2110A to work properly only when the factory settings for Windows have not been changed.

MP2110A operations are not guaranteed if program installation or update, including Windows Update, is performed.

Changing registries may cause abnormal operations.

2.9.1 Displaying Windows Desktop

The Windows desktop can be displayed as described below. To display the MP2110A application again, click **MX210000A** on the Windows taskbar.

When using Click panel and mouse:

1. Click **System Menu** on the left upper side of the application window.
2. Click **Minimize**.



When using keyboard:

Press the Windows + **D**. All windows will be minimized to display the Windows desktop.

2.9.2 Setting Control Panel

The system time, external display settings and Click panel settings are set at the Windows Control Panel. Do not change any settings other than those listed in Table 2.9.2-1.

Table 2.9.2-1 Description of Control Panel

Icon	Description
	<p><u>Date and Time</u></p> <ul style="list-style-type: none"> • Change the date, time and time zone as necessary. • Internet Time is set to off at factory shipment. Operation may be affected if this setting is changed.
	<p><u>Display</u> <u>Intel® HD Graphics</u></p> <ul style="list-style-type: none"> • Change this setting when connecting an external monitor to Display Port or HDMI connector. For details, refer to 2.9.3 “Setting External Monitor” for details. • Changing the screen resolution, refresh rate or power management, or enabling the screen saver may cause abnormal BERTWave operation.

2.9.3 Setting External Monitor

The external monitor resolution is changed using the following methods. MP2110A uses Windows Embedded Standard 7 (WES7) 64 bit version or Windows 10 IoT Enterprise 2019 LTSC (Win10). The setting method differs depending on the operating system.

For WES7:

1. Connect the external monitor to the monitor connector on the rear panel of the MP2110A.
2. Set the MP2110A and monitor power to On.
3. Click **System Menu**.
4. Click **Minimize**.
5. Right click on desk top.
6. Click **Screen resolution**.

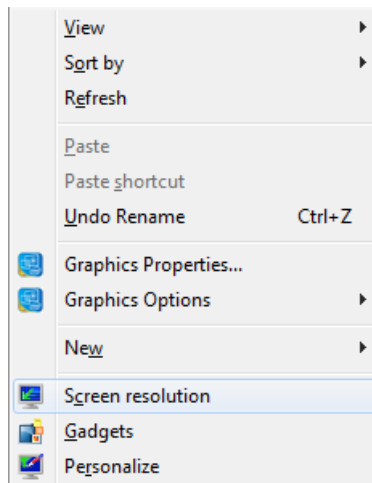

7. Change the external monitor resolution.
Specify **1280 × 800** or greater at Resolution to display the application window in full screen.

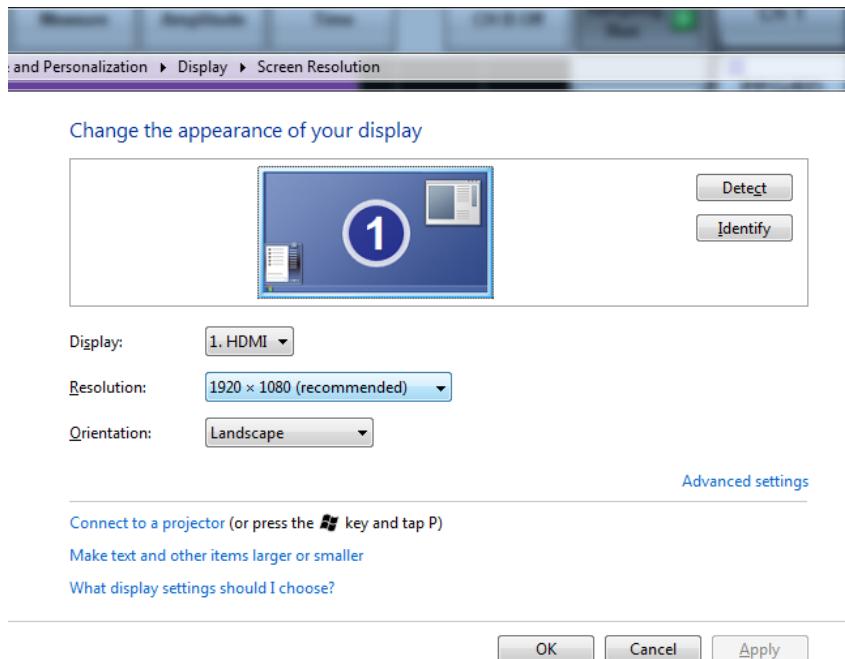

8. Click **OK**.
9. The dialog box confirming changes of the desktop appears. Click **Keep changes**.

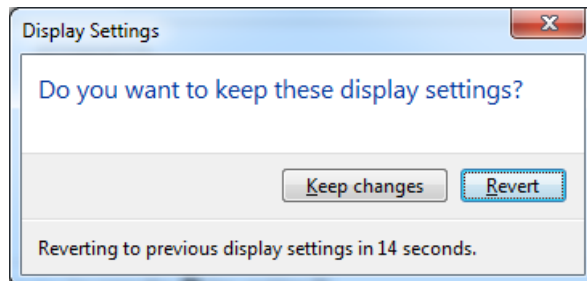

10. Click  on the task bar.
11. When the external monitor resolution is set to **1280 × 800**, click **System Menu - Dock/Undock** to fix the application window at top left of the screen (refer to 4.3.9 “Dock/Undock”).

Note:

Do not set the Control Panel - Display setting to anything other than **Smaller - 100% (default)**.

For Win10:

1. Connect the external monitor to the monitor connector on the rear panel of the MP2110A.
2. Set the MP2110A and monitor power to On.
3. Click **System Menu**.
4. Click **Minimize**.
5. Right click on desk top.
6. Click **Display Settings**.

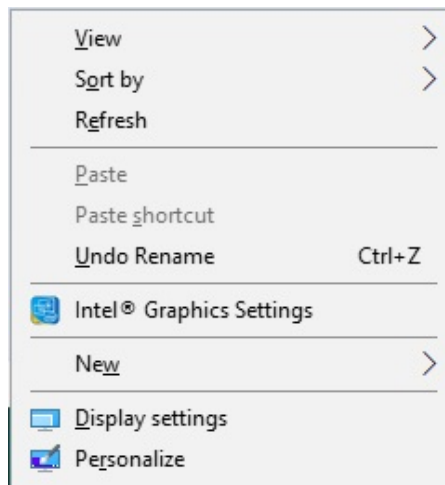

7. Change the external monitor resolution. Specify **1280 × 800** or greater at Resolution to display the application window in full screen.

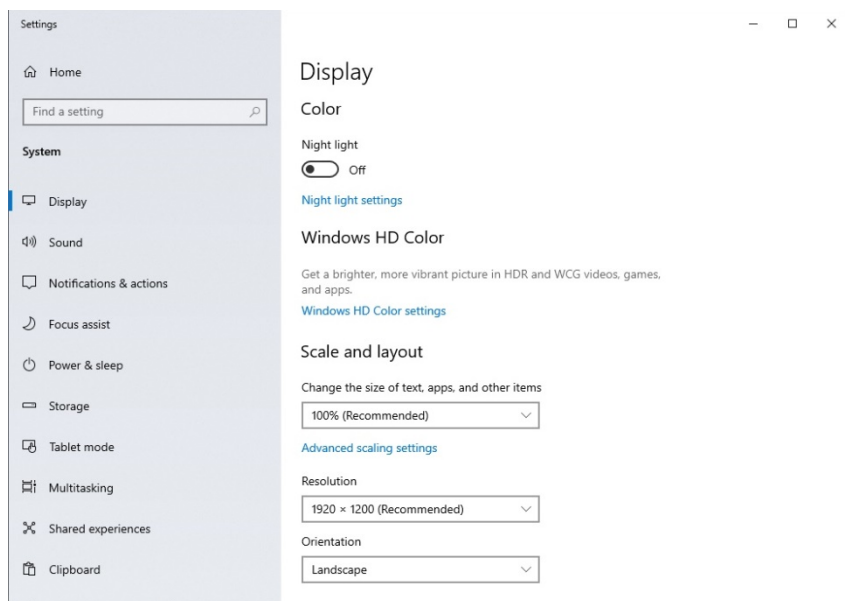

- The dialog box confirming changes of the desktop appears. Click **Keep changes**.

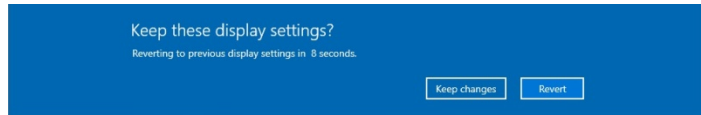

- Click  on the task bar.
- When the external monitor resolution is set to **1280 × 800**, click **System Menu - Dock/Undock** to fix the application window at top left of the screen (refer to 4.3.9 “Dock/Undock”).

Note:

Do not set the Control Panel - Display setting to anything other than **100% (Recommended)**.

2.10 Precautions for Preventing Damage

CAUTION

- Always use the supplied 3-pin power cord to ground both the MP2110A and DUT (included in test circuit). After confirming that both the MP2110A and DUT are grounded, use coaxial cables to connect them. NEVER connect the MP2110A and DUT without grounding, otherwise electrostatic discharge may damage the MP2110A.
 - Do not touch the core conductor of the connector or bring it into contact with metal. Doing so may damage the input circuit of the MP2110A.
-

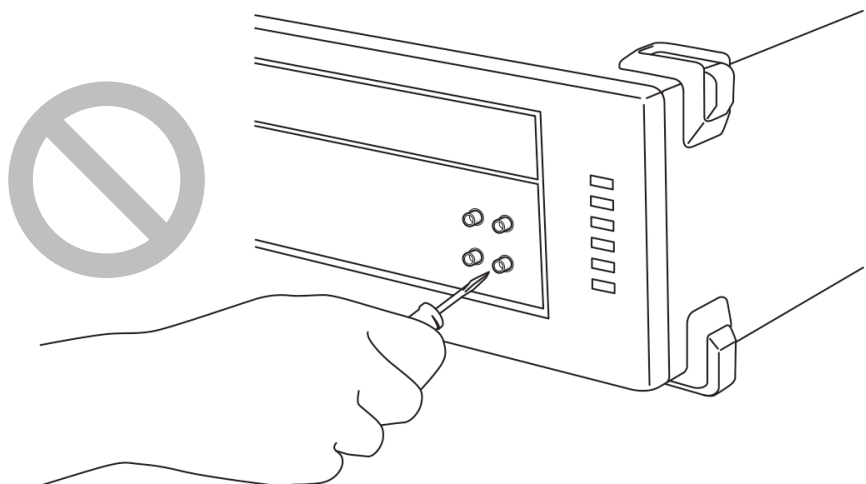
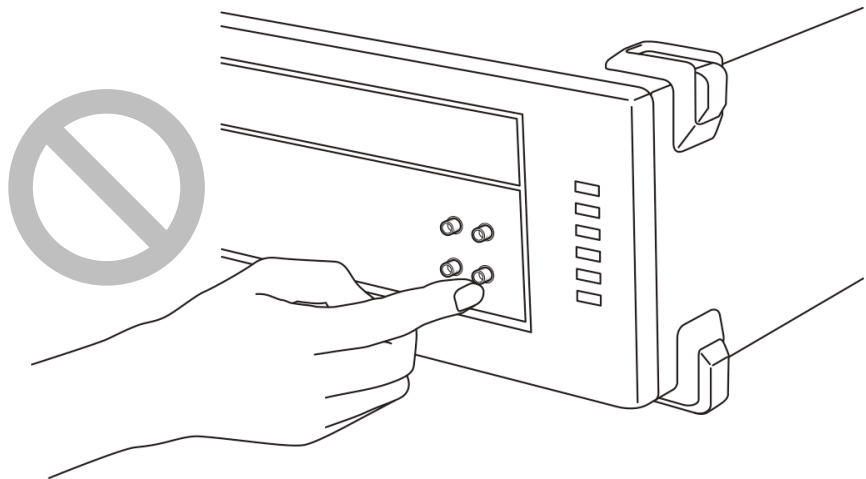

 **CAUTION**

Do not touch the core conductor of the coaxial cable connected to the input connector or bring it into contact with metal.

Doing so may damage the input circuit of the MP2110A.

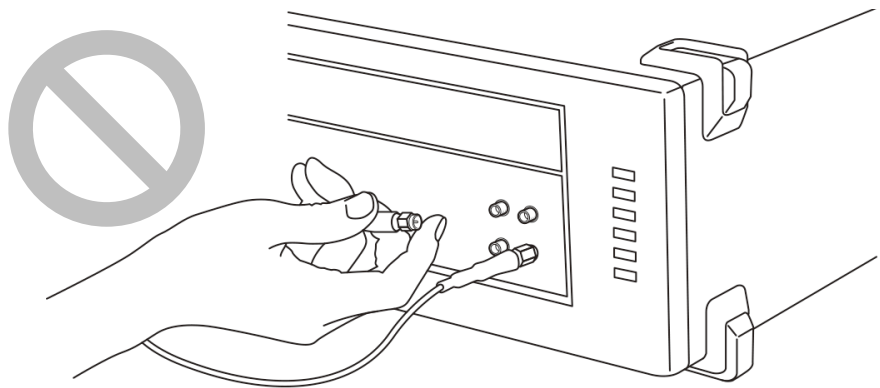

2

Before Use

 **CAUTION**

Do not touch the core conductor to the metal when connecting the coaxial cable to the connector.

Doing so may damage the input circuit of the MP2110A.

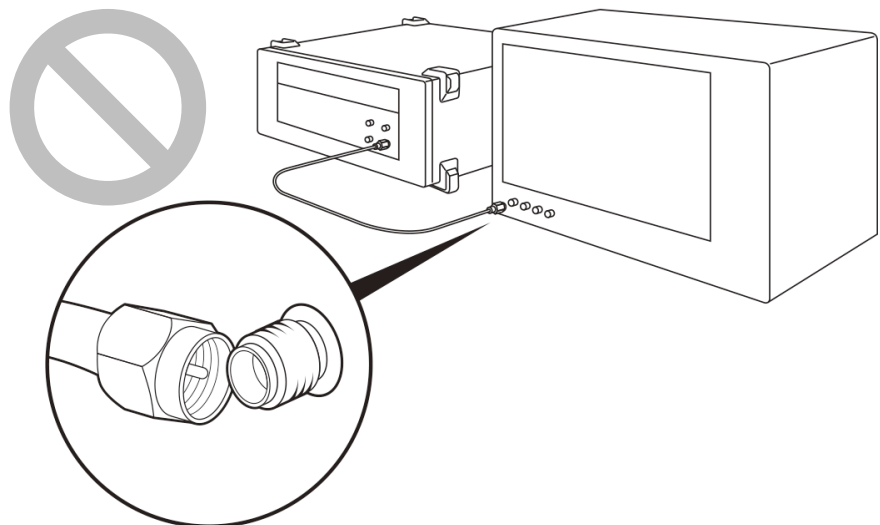

2.10.1 Precautions on Electrostatic Discharge and Electrical Overstress

CAUTION

- When signals are input to the MP2110A, avoid excessive voltage beyond the rating. Otherwise, the circuit may be damaged.
 - Never feed any current or input signals to the output connector.
 - As a countermeasure against static electricity, connect the ground structures (for example, frame ground) of external devices, including experimental circuits, to the ground terminal of the MP2110A by using ground wires before connecting the IO connector.
Shorten ground wires as much as possible.
 - To the input connector of the MP2110A, connect an attenuator that can protect the MP2110A without affecting measurement results. An attenuator with a bandwidth of 40 GHz or more is recommended.
 - The outer conductor and core of the coaxial cable may become charged as a capacitor. Use any metal to discharge the outer conductor and core before use.
 - The MP2110A has many important circuits and parts including hybrid ICs.
These parts are extremely sensitive to static electric charges, so never open the case of the MP2110A.
 - To prevent the risk of damage to the MP2110A from static electric charges, always use an antistatic mat on the workbench and ensure that the operator wears a grounded wrist strap.
Always ground the wrist strap to the workbench antistatic mat or the frame ground of the MP2110A.
-

CAUTION

- Always use 3-pin power cords when connecting external devices, including experimental circuits, to AC outlets. Connect the ground wires of external devices and MP2110A to a common ground.
- Turn on the external devices, including experimental circuits, before connecting them to the MP2110A. Use coaxial cables when connecting. On the contrary, disconnect the coaxial cables between external devices and the MP2110A before turning off the external devices.

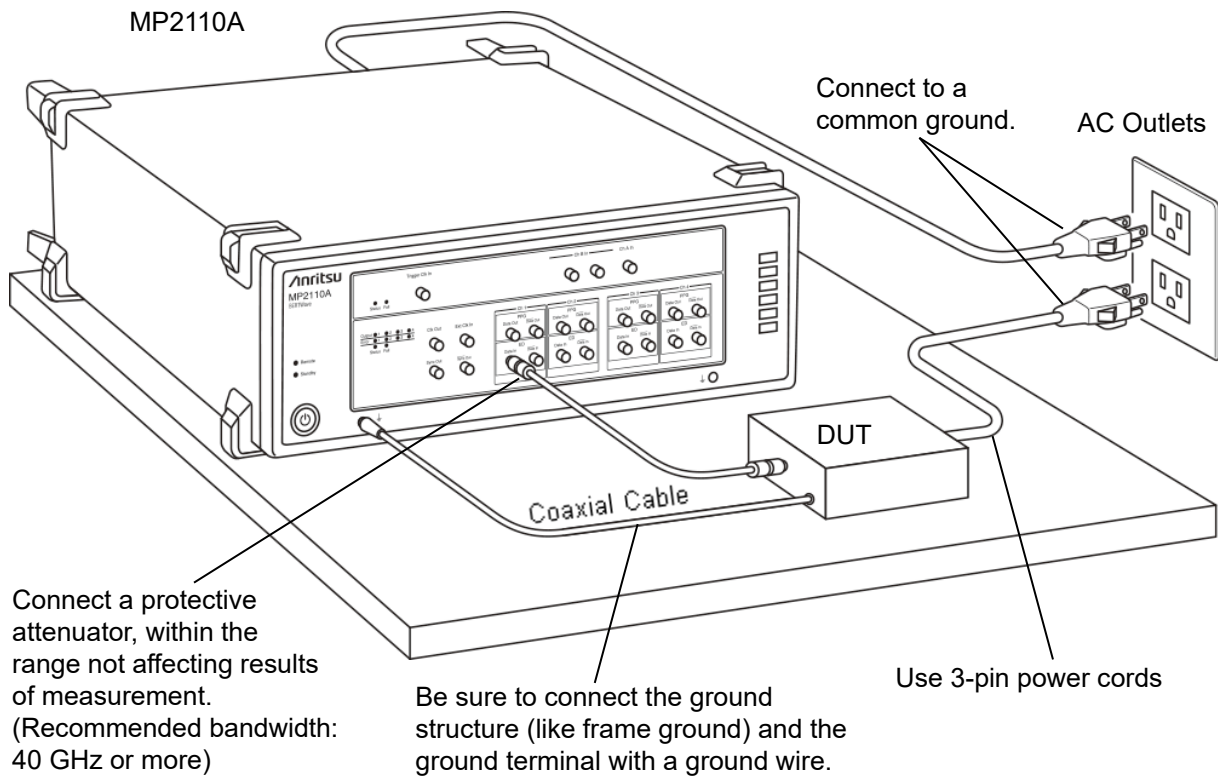

Figure 2.10.1-1 Example of Connection with DUT

Follow the procedure below to check for electrical overstress to the MP2110A before connecting DUT (Device Under Test).

Checking the ground connection using a tester

1. Connect DUT and the ground terminal of the MP2110A with a ground wire.
2. Turn on the power to DUT and MP2110A without connecting DUT to the I/O connectors of MP2110A.
3. Measure the voltage between DUT's ground structure and ground terminal of MP2110A with a tester in AC mode, and confirm the voltage is 0 V.

If the voltage measured in step 3 is not 0 V, there is a possibility that MP2110A and DUT may not be connected to a common ground. In this condition, do not connect the I/O connectors of MP2110A and DUT. Failure to do so may cause damage to MP2110A due to a voltage exceeding a rated value.

Review the ground wiring by, for example, changing the location of the DUT's ground wire connected to MP2110A so that the voltage measured in step 3 to be 0 V.

Notes:

If it is impossible to connect a ground wire to DUT, follow the instructions below so that the voltage to be measured in step 3 becomes 0 V.

- Check that the 3-pin power cords described in 2.3.2 "Connecting Power Cord" are used for the MP2110A and DUT.

When the 3-pin power cords are used, take the following actions:

- There may be a disconnection in the ground terminal of the used power cord. Replace it with a different 3-pin power cord.
- There is a possibility that the ground terminal inside the AC outlets to which the 3-pin power cords of MP2110A and DUT are connected is not connected to ground. Connect the 3-pin power cords to different AC outlets.

Checking the output waveform with an oscilloscope

1. Connect the DUT and the oscilloscope using a cable with an impedance of 50 Ω .
2. Set the input impedance of the oscilloscope to 50 Ω .
3. Observe the waveform with the oscilloscope, and perform the following operations to check the observed waveform for surge voltage exceeding the rated voltage*.

There is a risk of damage if a voltage exceeding the rated voltage* is generated.

- Turning On/Off the DUT power
- Outputting a pulse from DUT
- Connecting and disconnecting the cable between DUT and the BERTWave

*: The rated voltages for MP2110A are shown in the table below.

Table 2.10.1-1 Rated Voltages of Input Connector

Connector		Rated Voltage
ED	Data In, $\overline{\text{Data}}$ In	1 V _{p-p}
Scope	Ch A, Ch B electrical	± 2 V
	Trigger Clk In	2 V _{p-p}
	CRU In	1 V _{p-p}

2.10.2 Precautions When Using Bias-T

When connecting an external device such as a Bias-T to the output connectors of the MP2110A, if the output signal includes any DC voltage, variations in the output of the DC power supply or load may change the level of the output signal, risking damage to the internal circuits.

CAUTION

- Do not connect or disconnect any external devices while DC voltage is impressed.
- Only switch DC power sources ON and OFF when all equipment connections have been completed.

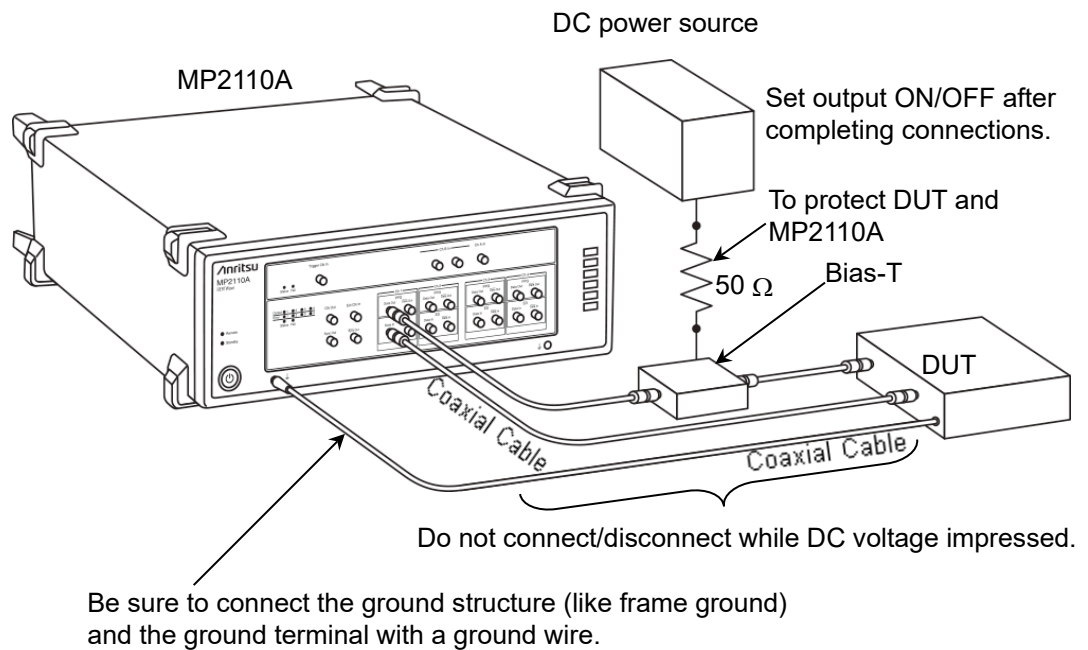

Figure 2.10.2-1 Bias-T Connection Example

<Recommended procedures>

Measurement Preparation 1:

1. Connect the MP2110A and all equipment.
2. Set the DC power supply output to ON.
3. Set the MP2110A output to ON, and start measurement.

Measurement Preparation 2:

1. Set the MP2110A output to OFF.
2. Set the DC power supply output to OFF.
3. Disconnect the MP2110A and all equipment, or change the DUT connections.

Since even unforeseen fluctuations in DC voltage and load (open or short circuits at the MP2110A output side and changes caused by using a high-frequency probe, etc.) can damage the DUT and the MP2110A, we recommend connecting a 50 Ω resistance in series with the DC terminal of the Bias-T to prevent risk of damage.

2.11 Windows Security Measures

MP2110A uses Windows Embedded Standard 7 (WES7) 64 bit version or Windows 10 IoT Enterprise 2019 LTSC (Win10). When connecting MP2110A to a network, make sure the network is secure and protected from viruses. Additionally, it is recommended to take the following security measures to add protection against malware (malicious software such as viruses).

- Activating firewall
- Installing important Windows update programs
- Using antivirus software

The security measure settings condition of this product can be confirmed from the Control Panel of Windows.

For WES7:

1. Click **Start** → **Control Panel** from the Windows menu bar hidden in the lower part of the screen.
2. Click **System and Security** → **Action Center**.
3. Click **Security**, and confirm security measures settings condition.

For Win10:

1. Click **Start** (☰) → **Windows system** → **Control Panel** from the Windows menu bar hidden in the lower part of the screen.
2. With View by: Category, click **System and Security** → **Security and Maintenance**.
3. Click **Security**, and confirm security measures settings condition.

Note:

Security warnings are not displayed by factory default.

CAUTION

If MP2110A is connected to an external network like the Internet, there may be a risk of causing unexpected problems or suffering unexpected losses. Anritsu Corporation is not responsible for any losses caused by connecting it to a network.

2.11.1 Activating Firewall

It is recommended to turn On the Windows firewall on MP2110A.

For WES7:

Windows firewall On/Off setting (WES7):

1. Click **Start** → **Control Panel** from the Windows menu bar hidden in the lower part of the screen.
2. Click **System and Security** → **Windows Firewall** to show Windows Firewall window.

Note:

Depending on when MP2110A was shipped, factory default setting of Windows firewall might be set to Off.

3. Click **Turn Windows Firewall on or off** found in left side of Windows Firewall window.

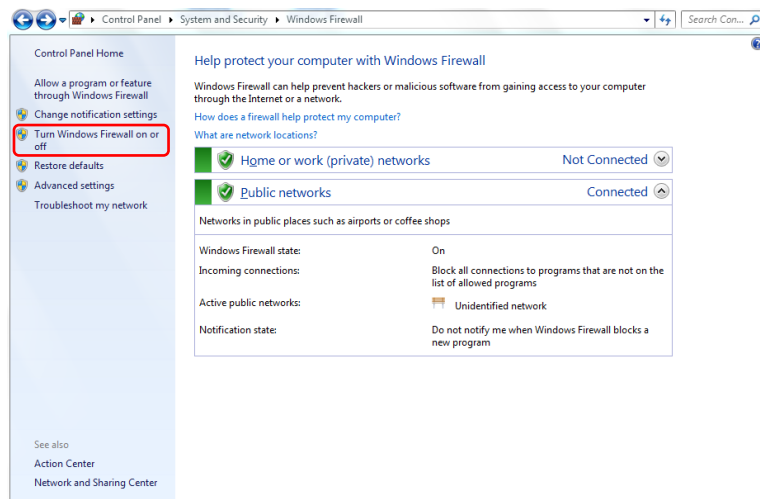

Figure 2.11.1-1 Windows Firewall Window

4. Customize Settings window will be shown where Windows firewall On/Off settings can be changed.

Use MP2110A with the following checkboxes Off (unchecked).

- **Block all incoming connections, including those in the list of allowed programs**
- **Notify me when Windows Firewall blocks a new program**

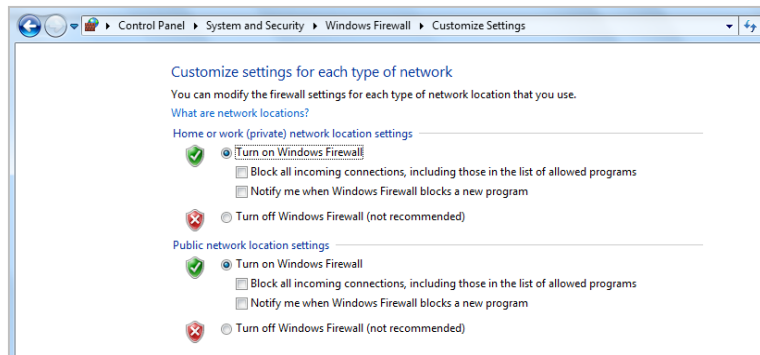

Figure 2.11.1-2 Customize Settings Window

Confirmation and setting of allowed programs through Windows firewall (WES7):

Even if Windows firewall is On, in order for this instrument to operate properly, it is necessary to set as allowed programs those that enable external communication from MP2110A.

Note:

Depending on when MP2110A was released, factory default setting for allowed programs might not be set beforehand.

- 1. Click **Allow a program or feature through Windows Firewall** found in left side of Windows Firewall window.

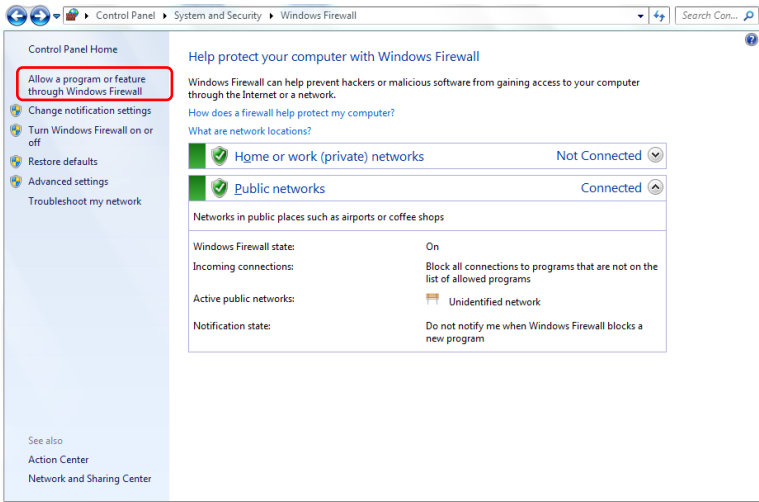

Figure 2.11.1-3 Windows Firewall Window

2

Before Use

2. Allowed Programs window will be shown where programs allowed through Windows firewall can be confirmed.

Confirm if **MX210000A** is found and set to On (checked) under Allowed programs and features.

When no such information is displayed, it is necessary to add **MX210000A**.

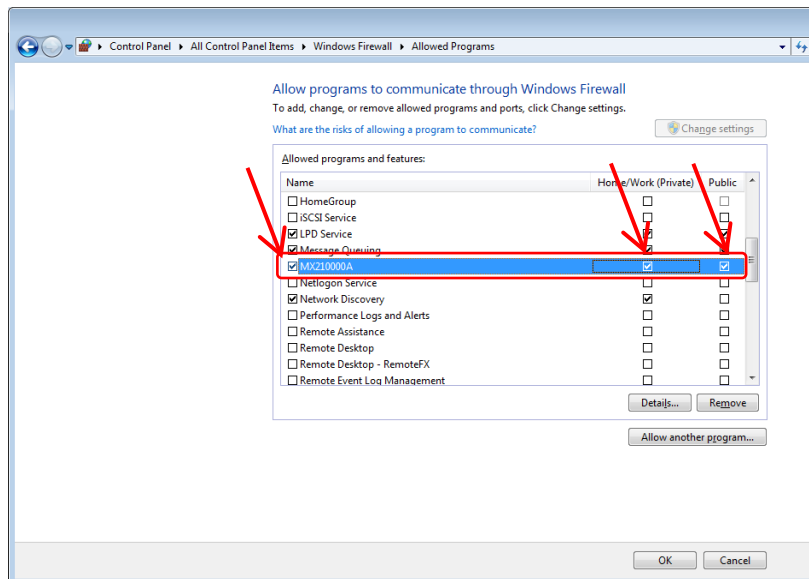

Figure 2.11.1-4 Allowed Programs Window

Procedure to add **MX210000A** when it is not registered (WES7):

1. Use the mouse to click **Allow another program...** found in Allowed Programs window.

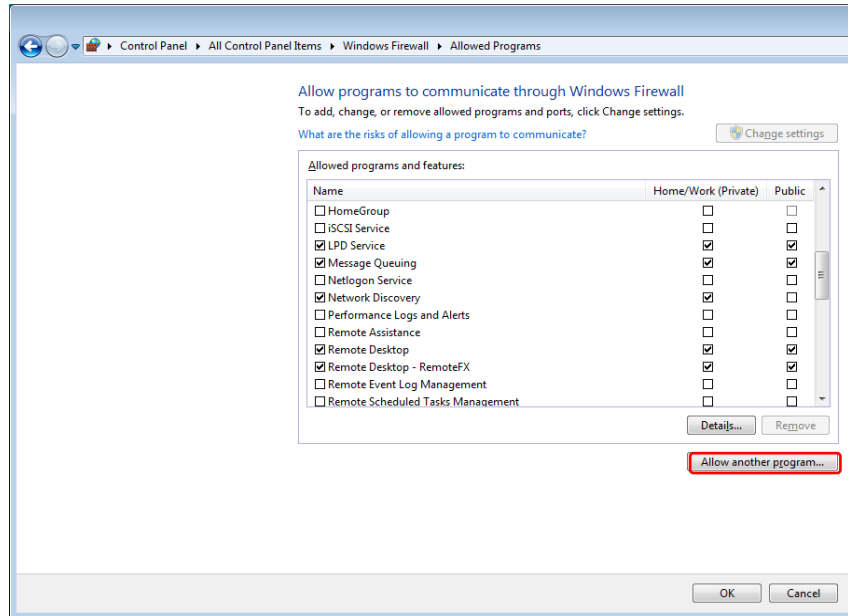

Figure 2.11.1-5 Allowed Programs Window

2. In Add a Program window, select **MX210000A**, and click **Add**.

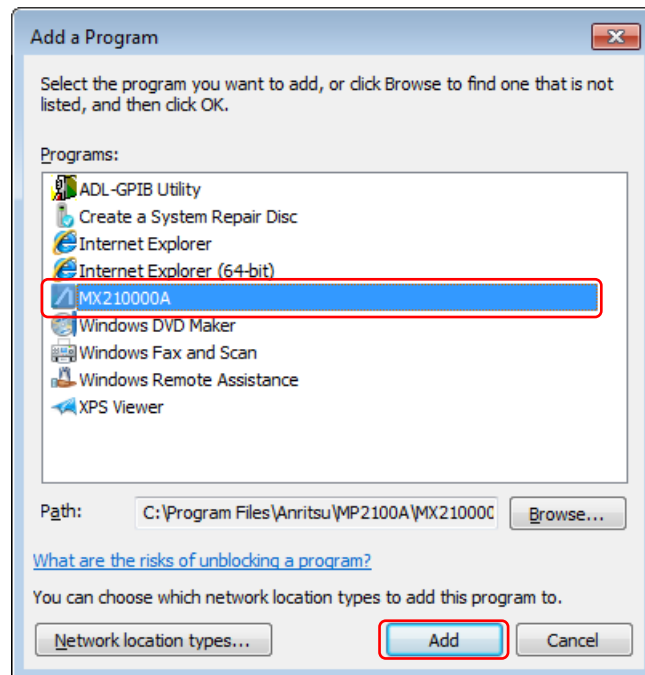

Figure 2.11.1-6 Add a Program Window

2

Before Use

3. **MX210000A** is added to Allowed programs and features. Confirm if **MX210000A** is found and set to On (checked).

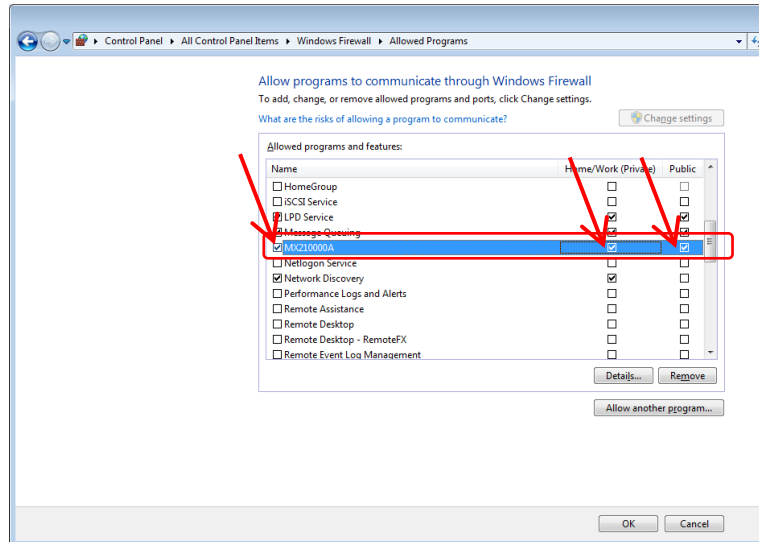

Figure 2.11.1-7 Allowed Programs Window

For Win10

Windows firewall On/Off setting (Win10)

1. Click **Start** (Windows logo) → **Windows system** → **Control Panel** from the Windows menu bar hidden in the lower part of the screen.
2. With View by: Category, click **System and Security** → **Windows Defender Firewall** to show Windows Defender Firewall window.

Note:

Depending on when MP2110A was shipped, factory default setting of Windows firewall might be set to On.

3. Click **Turn Windows Defender Firewall on or off** found in left side of Windows Defender Firewall window.

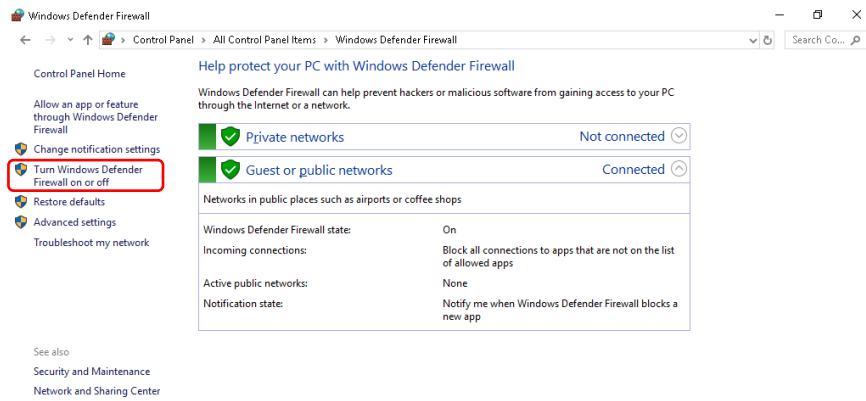

Figure 2.11.1-8 Windows Defender Firewall Window

4. Customize Settings window will be shown where Windows firewall On/Off settings can be changed.

Use MP2110A with the following checkboxes Off (unchecked).

- **Block all incoming connections, including those in the list of allowed apps**
- **Notify me when Windows Firewall blocks a new app**

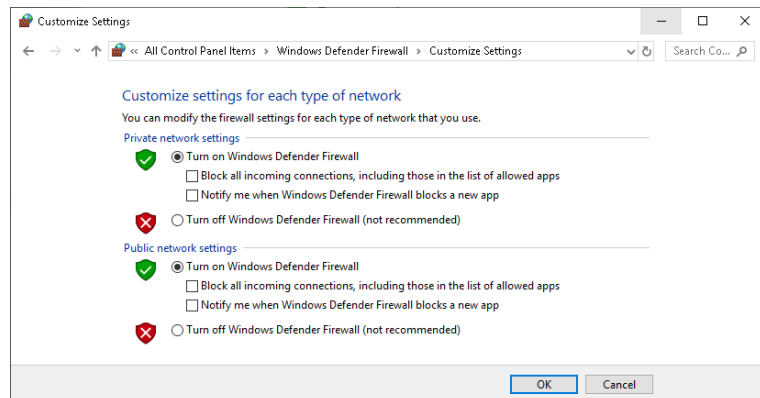

Figure 2.11.1-9 Customize Settings Window

Confirmation and setting of allowed programs through Windows firewall (Win10)

Even if Windows firewall is On, in order for this instrument to operate properly, it is necessary to set as allowed programs those that enable external communication from MP2110A.

1. Click **Allow an app or feature through Windows Defender Firewall** found in left side of Windows Defender Firewall window.

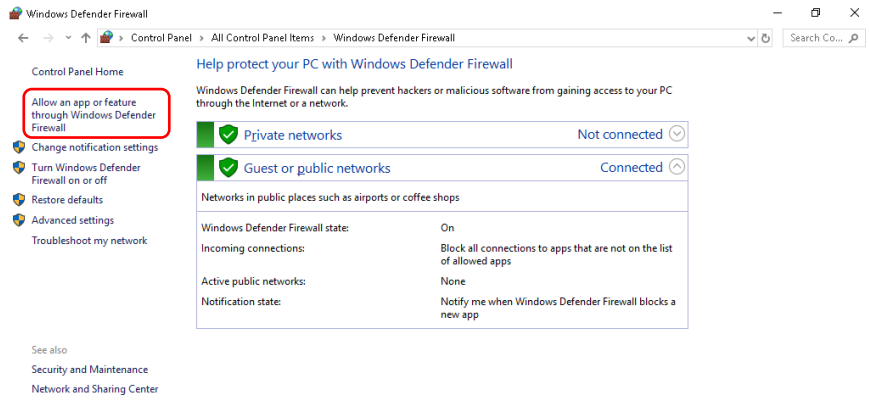

Figure 2.11.1-10 Windows Defender Firewall Window

2. Allowed apps window will be shown where programs allowed through Windows firewall can be confirmed.

Confirm if **MX210000A Main Application** is found and set to On (checked) under **Allowed apps and features**.

When no such information is displayed, it is necessary to add **MX210000A Main Application**.

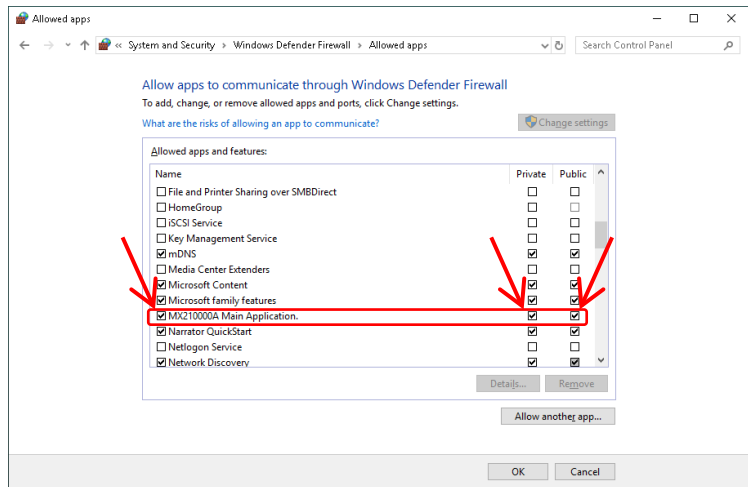

Figure 2.11.1-11 Allowed apps Window

Procedure to add **MX21000A Main Application** when it is not registered (Win10)

1. Use the mouse to click **Allow another apps...** found in Allowed apps window.

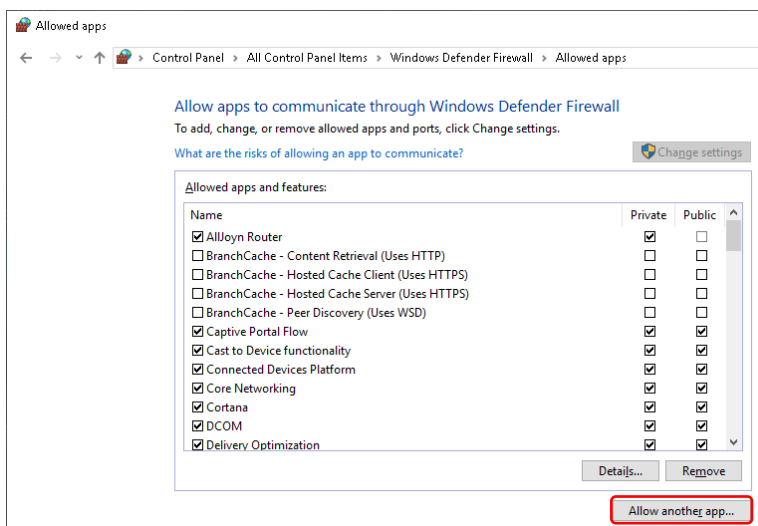

Figure 2.11.1-12 Allowed apps Window

2. Add an app window is shown. Click **Browse....**

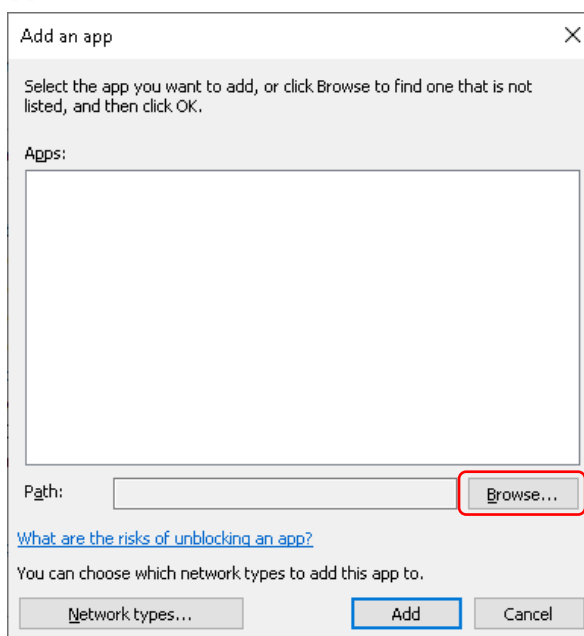

Figure 2.11.1-13 Add an app Window

3. Browse window of Add an app is shown.

Select C:\Program

Files\Anritsu\MP2100A\MX210000A>MainApp.exe, and click

Open.

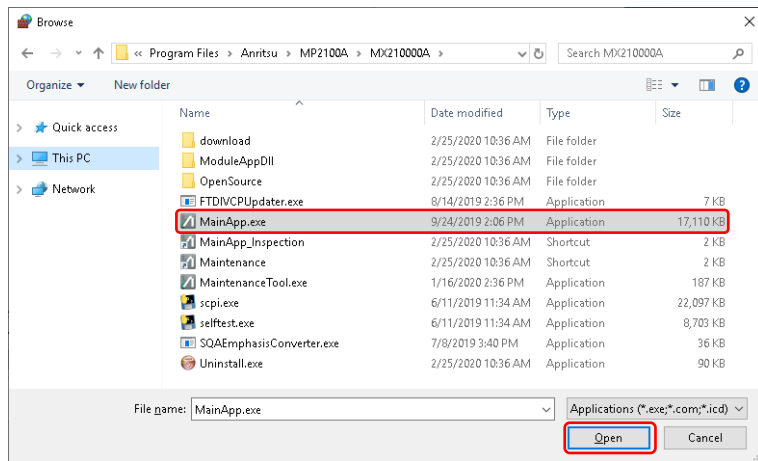

Figure 2.11.1-14 Browse Window of Add an app

4. In Add an app window, select **MX210000A Main Application**, and click **Add**.

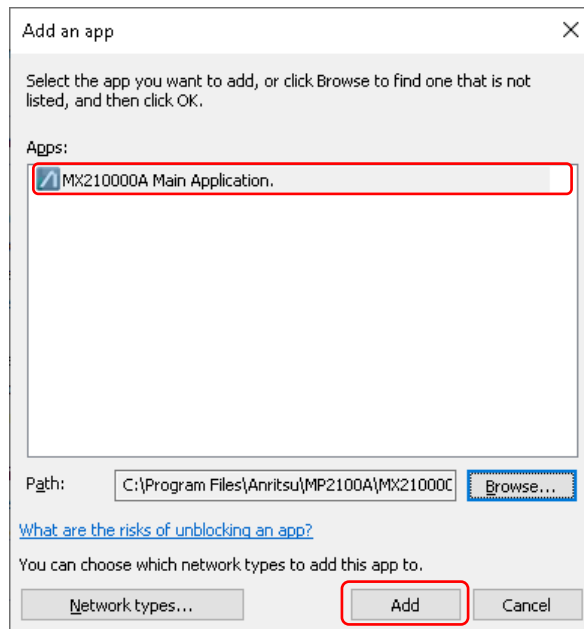

Figure 2.11.1-15 Add an app Window

- 5. **MX21000A Main Application** is added to **Allowed apps and features**. Confirm if **MX21000A Main Application** is found and set to On (checked).

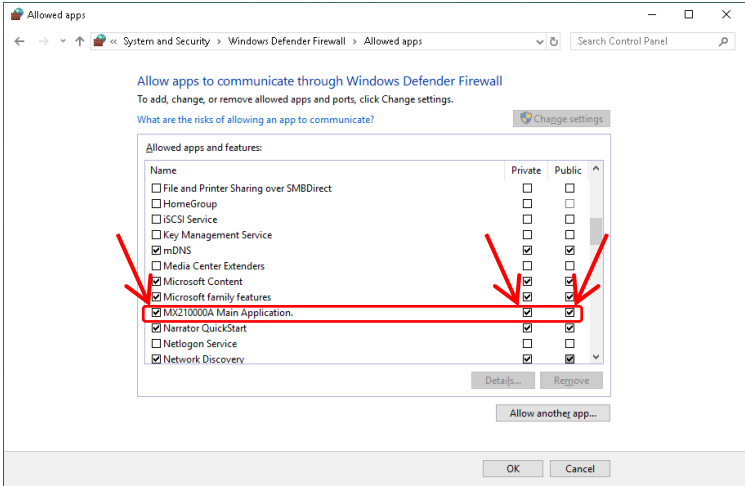

Figure 2.11.1-16 Allowed apps Window

2

Before Use

2.11.2 Installing Windows Important Update Programs (Windows Update)

It is necessary to regularly check for important Windows update programs and keep them up-to-date. However, the performance of MP2110A could decrease while downloading and installing Windows updates. Turn off automatic updates in Windows. Instead, it is recommended to manually check for, download, and install new updates on a periodic basis, avoiding the operating hours of MP2110A.

Windows Update setting and execution:

For Windows 7:

1. Click **Start** → **Control Panel** from the Windows menu bar hidden in the lower part of the screen.
2. Click **System and Security** → **Windows Update** to show Windows Update window.
3. To turn off automatic updates, click **Change settings** found in left side of Windows Update window.



Figure 2.11.2-1 Windows Update Window

4. Select **Never check for updates (not recommended)** in Important updates, then click **OK**.

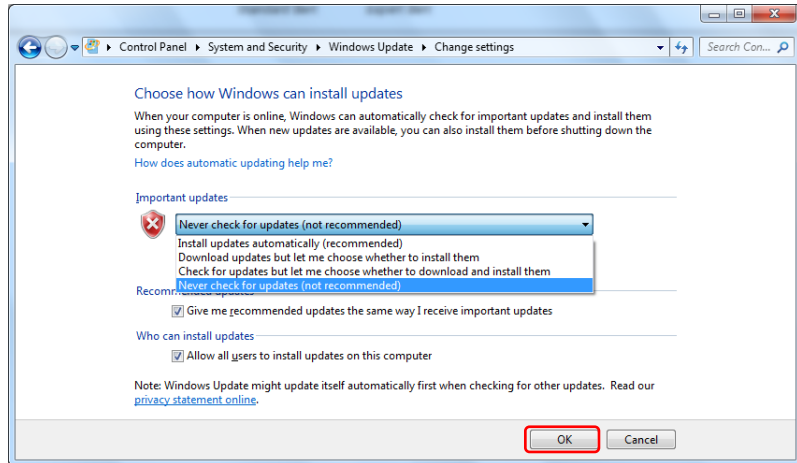

Figure 2.11.2-2 Change settings Window

5. To check for newly available update programs (manual update), click **Check for updates** in Windows Update window.



Figure 2.11.2-3 Windows Update Window (manual update)

6. When a new update program is found, download and install following the displayed instructions.

2

Before Use

For Windows 10:

1. Click **Start** (Windows logo) → **Settings** (gear icon) from the Windows menu bar hidden in the lower part of the screen.
2. Click **Update and Security** to show Windows Update window.
3. To turn off automatic updates, select **Windows Update** found in left side of Windows Update window, and then click **Advanced options**.

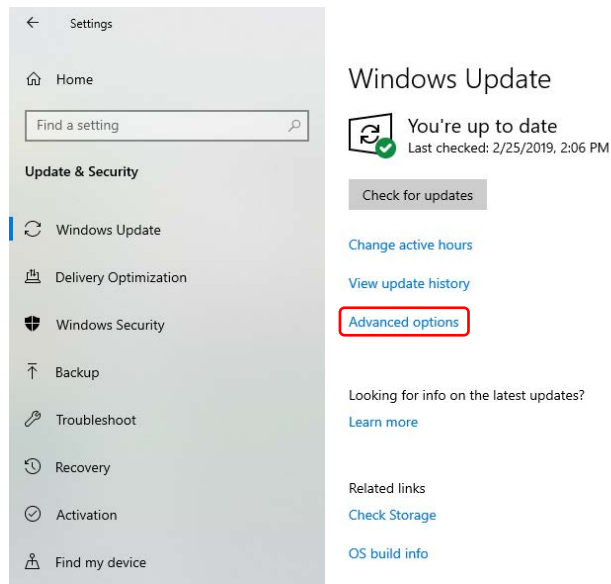

Figure 2.11.2-4 Windows Update Window

4. Advanced options window will be shown. Confirm if **Automatically download updates, even over metered data connections (charges may apply)** is set to Off.

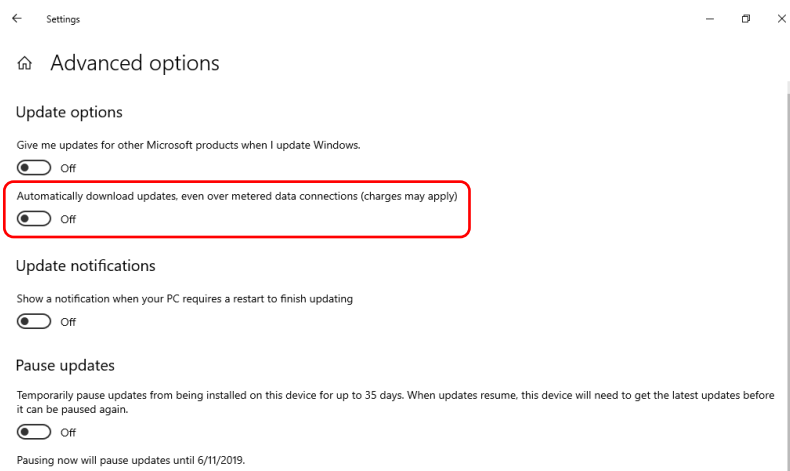

Figure 2.11.2-5 Advanced options Window

- To check for newly available update programs (manual update), click **Check for updates** in Windows Update window.

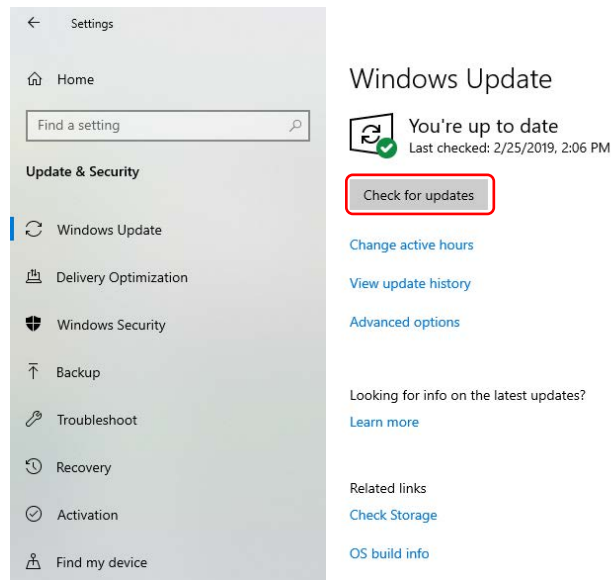

Figure 2.11.2-6 Windows Update Window (manual update)

- When a new update program is found, download and install following the displayed instructions.

2

Before Use

2.11.3 Using Antivirus Software

It is recommended to install antivirus software on MP2110A. However, if the antivirus software updates virus definition data automatically or runs full scan in the background, the performance of MP2110A could decrease. Do not allow the software to execute them. Instead, it is recommended to manually run them on a periodic basis, avoiding the operating hours of MP2110A. The antivirus software that checked operation in MP2110A is shown below.

- Trend Micro OfficeScan XG

Notes:

- Refer to the antivirus software operation manual for its installation and operation procedures. Although it is confirmed that no negative effects in the general usage of MP2110A are caused by using the software mentioned above, there is no guarantee for different software even if containing similar functions.
- Windows Defender is a default antivirus feature in Windows 10 and has been set to off at the factory before shipment.

Chapter 3 Measurement Examples

This chapter explains examples of how to connect the MP2110A and the DUT and their measurement procedures.

When changing the optical level input to the DUT such as the receiver sensibility measurement, connect other measurement instruments such as variable optical attenuator.

When using the MP2110A-x30, x39, x40 or x49 option, replace the connector names in this chapter as follows:

Ch A In → A

Ch B In → B

3.1	Measuring Bit Error Rate.....	3-2
3.2	Measuring Waveform.....	3-4
3.3	Measuring Multichannel Optical Module Bit Error Rate.....	3-10

3.1 Measuring Bit Error Rate

When the DUT input/output signal is electrical:

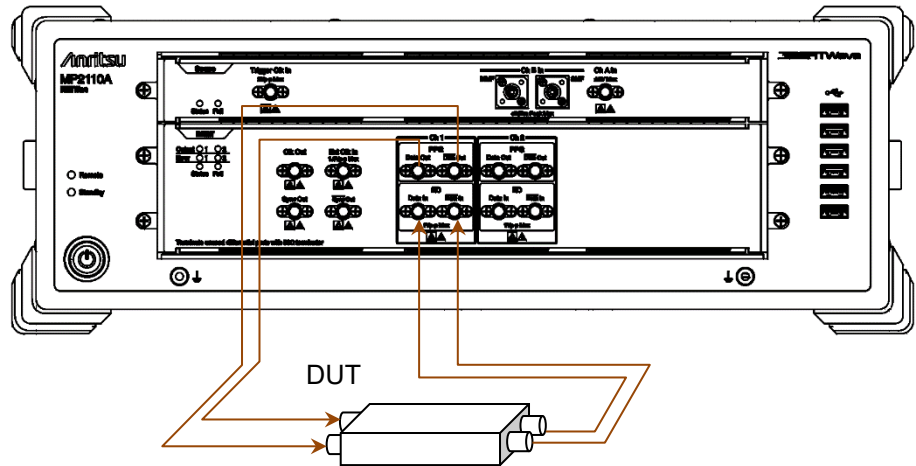

Figure 3.1-1 Making Connections Using Electrical Signal

1. Connect the DUT input connectors to PPG1 **Data Out** and **Data Out** connectors using the coaxial cables.
If the DUT has only one input connector, connect it to the **Data Out** connector of PPG1. Also, connect the coaxial terminator, which is attached to the MP2110A standard configuration, to the **Data Out** connector.
2. Connect the DUT output connectors to ED1 **Data In** and **Data In** connectors using the coaxial cables.
If the DUT has only one output connector, connect it to the **Data In** connector of ED1. Also, connect the supplied open to the **Data In** connector.

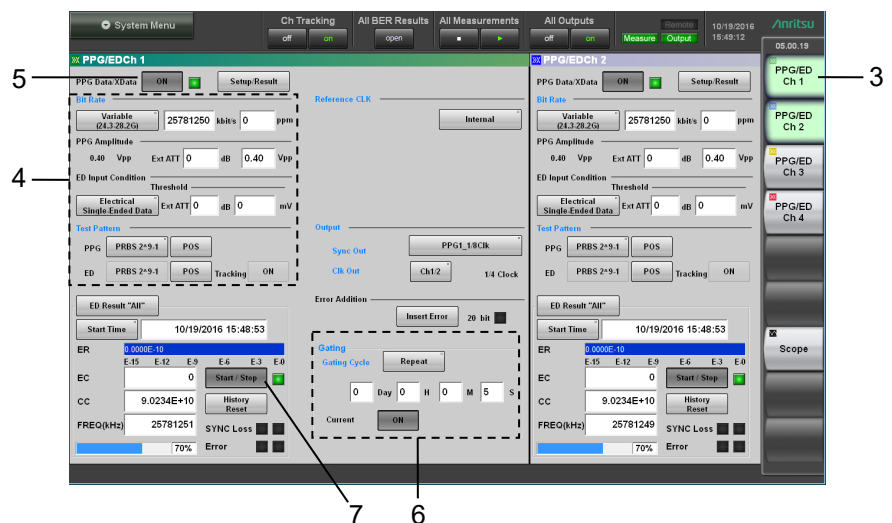

Figure 3.1-2 User Interfaces Used For Measuring Bit Error Rate (Numbers Shown Correspond to Step Numbers.)

3. In the application window, click **PPG/ED Ch1**.
4. Set Bit Rate, PPG Amplitude, ED Input Condition and Test Pattern. Refer to Chapter 5, “How to Operate BERT”, for details of the operation method.
5. Click the PPG Data XData button and set the display to **ON**. Check the following items.
 - The Output lamp 1 on the BERT panel is lit. (Refer to Figure 2.2.1-3.)
 - In the application window, the SYNC Loss and Error indicators are off.
6. Set Gating.
7. Click **Start/Stop**. When the time set at Gating elapses, the measurement values are displayed at ER, EC, CC and FREQ (kHz).

3.2 Measuring Waveform

When measuring the DUT with electrical signal inputs and outputs:
Input the output signal of the built-in PPG to the DUT, and then measure the DUT output using the sampling oscilloscope.

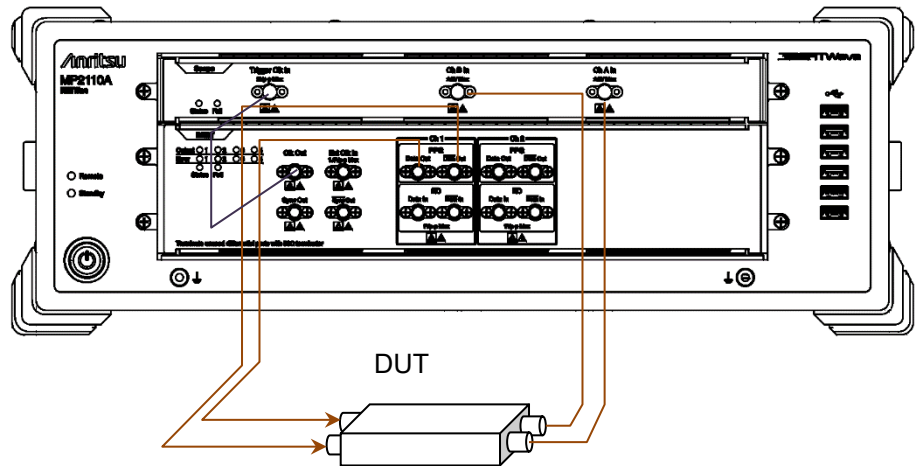

Figure 3.2-1 When Measuring DUT With Electrical Signal Inputs and Outputs (MP2110A-x12, x21)

1. Connect the DUT input connectors to PPG1 **Data Out** and **Data Out** using coaxial cables.
If the DUT has only one input connector, connect it to the PPG1 **Data Out**. Also, connect the coaxial terminator included as a standard accessory to the **Data Out**.
2. Connect the **Clk Out** (or **Sync Out**) on BERT to **Trigger Clk In** on Scope using a coaxial cable.
When the **Sync Out** is connected, connect the supplied coaxial terminator to **Sync Out**.
3. Connect the DUT output connectors to **Ch A In** and **Ch B In** on the sampling oscilloscope using coaxial cables.
When the amplitude of the input signal is greater than 400 mVp-p, connect the attenuators to **Ch A In** and **Ch B In** for more accurate measurement.

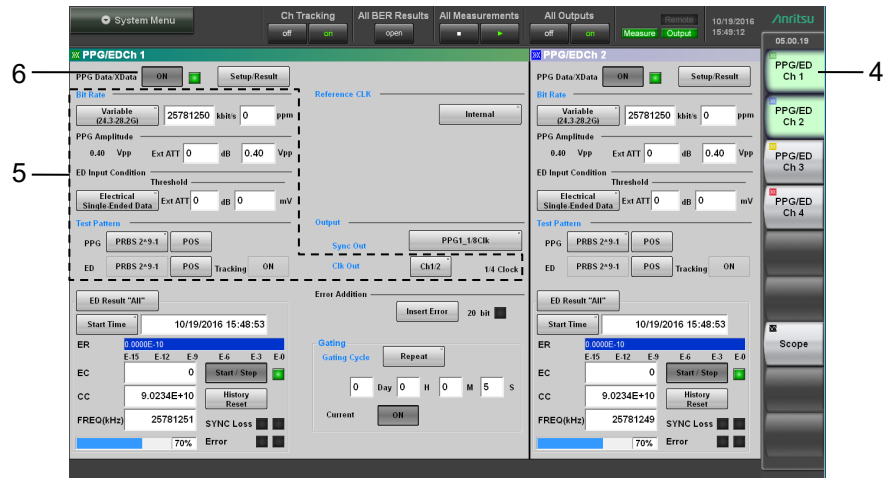

Figure 3.2-2 User Interfaces Used For Operating PPG (Numbers Shown Correspond to Step Numbers.)

4. In the application window, click **PPG/ED Ch1**.
5. Set Clk Out, Bit Rate, PPG Amplitude and Test Pattern. Refer to Chapter 5, “How to Operate BERT” for details of the operation method.
6. Click the PPG Data XData button and set the display to **ON**. Check the following items.
 - The Output lamp 1 on the BERT panel is lit. (Refer to Figure 2.2.1-3.)
 - In the application window, the SYNC Loss and Error indicators are off.

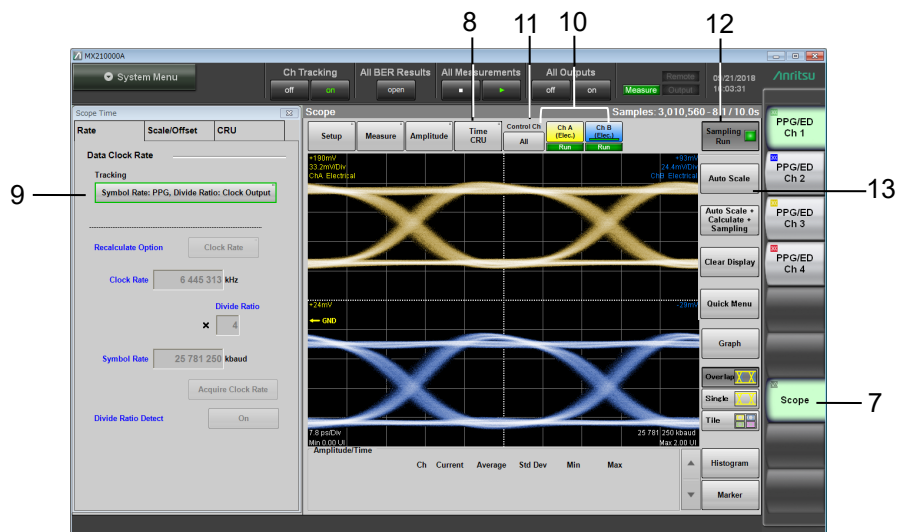

Figure 3.2-3 User Interfaces Used For Operating Scope (Numbers Shown Correspond to Step Numbers.)

7. Click **Scope**.
8. Click **Time**.

9. Click **Rate** and set Tracking. Refer to Chapter 6, “How to Operate Sampling Oscilloscope” for details of the operation method.
10. Click **Ch A** and **Ch B**.
11. Click the **Control Ch** button and set the display to **All**.
12. Click **Sampling**, and you will see that **Sampling** is followed by **Run**.
13. When the waveform is displayed, click **Auto Scale**.

When the DUT is an optical transceiver:

When the MP2110A-x22, x23, x25, x26, x30, x32, x33, x35, x36, x39, x40, x42, x43, x45, x46 or x49 is selected, the output waveform of the optical transceiver can be measured using the O/E.

Input the output signal of the built-in PPG to the DUT, and then connect the DUT optical output to the SMF or MMF.

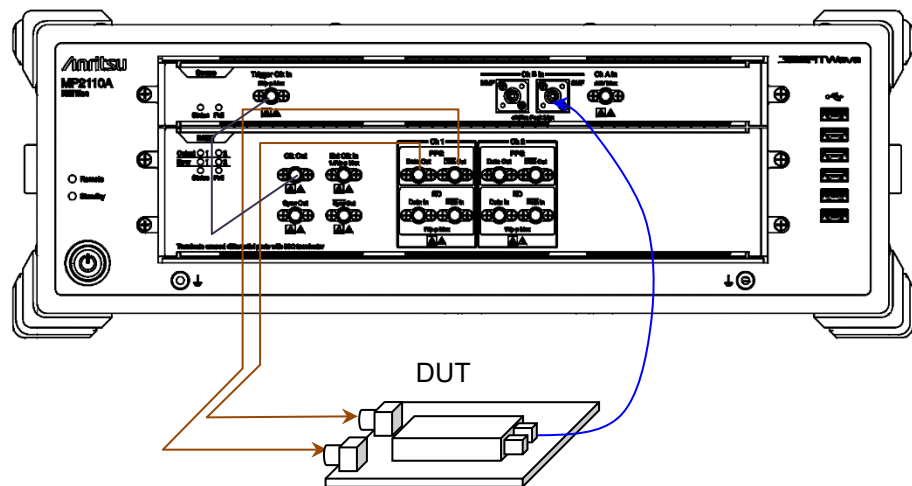

Figure 3.2-4 When DUT is Optical Transceiver (MP2110A-x12, x23)

1. Connect the DUT input connectors to PPG1 **Data Out** and **Data Out** using coaxial cables.
If the DUT has only one input connector, connect it to the PPG1 **Data Out**. Also, connect the coaxial terminator included as a standard accessory to the **Data Out**.
2. Connect the DUT optical output connector to **Ch B In** using an optical fiber. When the DUT wavelength is 850 nm, connect it to **MMF**. When the DUT wavelength is 1310 nm or 1550 nm, connect it to **SMF**.
3. Connect the **Clk Out** (or **Sync Out**) to **Trigger Clk Input** using a coaxial cable.

When the **Sync Out** is connected, connect the supplied coaxial terminator to **Sync Out**.

CAUTION

Check that the DUT optical output level does not exceed the rated optical input level for Ch B In.

There is a risk of damaging the built-in O/E module if the optical power exceeding the rated optical input level is applied to the Ch B In connector.

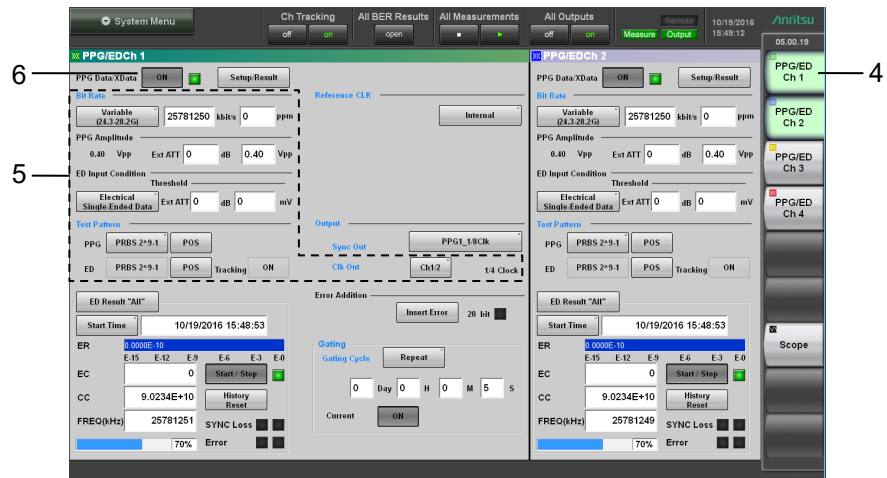

Figure 3.2-5 User Interfaces Used for Operating PPG (Numbers Shown Correspond to Step Numbers.)

4. In the application window, click **PPG/ED Ch1**.
5. Set Clk Out, Bit Rate, PPG Amplitude and Test Pattern. Refer to Chapter 5, “How to Operate BERT” for details of the operation method.
6. Click the PPG Data XData button and set the display to **ON**. Check the following items.
 - The Output lamp 1 on the BERT panel is lit. (Refer to Figure 2.2.1-3.)
 - In the Application window, the SYNC Loss and Error indicators are off.

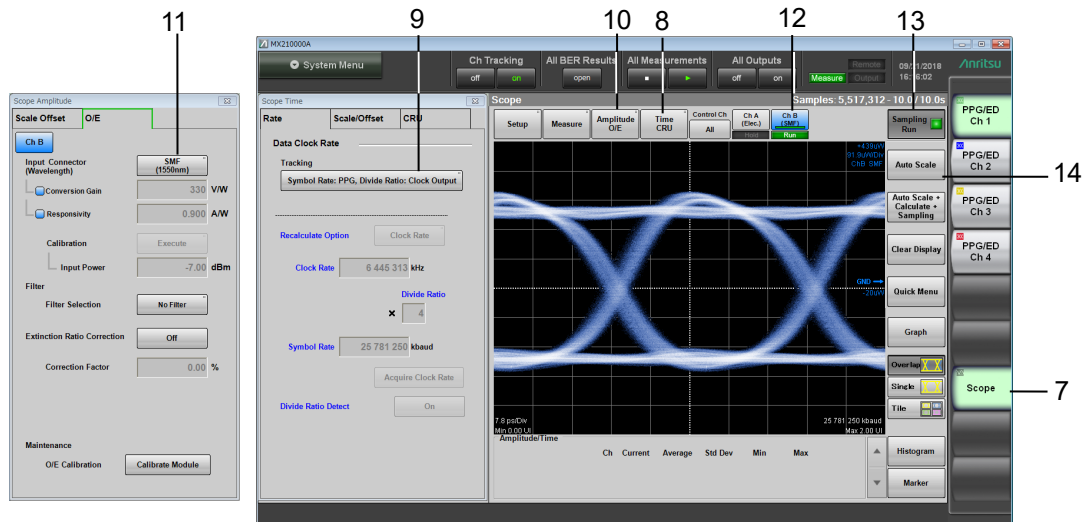

Figure 3.2-6 User Interfaces Used for Operating Scope (Numbers Shown Correspond to Step Numbers.)

7. Click **Scope**. Refer to Chapter 6, “How to Operate Sampling Oscilloscope”, for details of the operation method.
8. Click **Time**.
9. Click **Rate** and set Tracking.
10. Click **Amplitude O/E**.
11. Click **O/E** and set Input Connector (Wavelength).
12. Click **Ch B**.
13. Click **Sampling**, and you will see that **Sampling** is followed by **Run**.
14. When the waveform is displayed, click **Auto Scale**.

3.3 Measuring Multichannel Optical Module Bit Error Rate

This section explains the CFP4 module measurement method as an example of multichannel optical module.

The CFP4 module contains four pairs of transmitters and receivers. With the MP2110A-x14, the CFP4 module bit error rate can be measured for four channels simultaneously.

If using a separate CFP4 for transmission in addition to the DUT CFP4, connect as follows. Use coaxial cables of the same length as for between **Data Out** and **Data Out** to connect the BERTWave and CFP4. Bit error rate cannot be measured correctly if different length coaxial cables are used.

3.3 Measuring Multichannel Optical Module Bit Error Rate

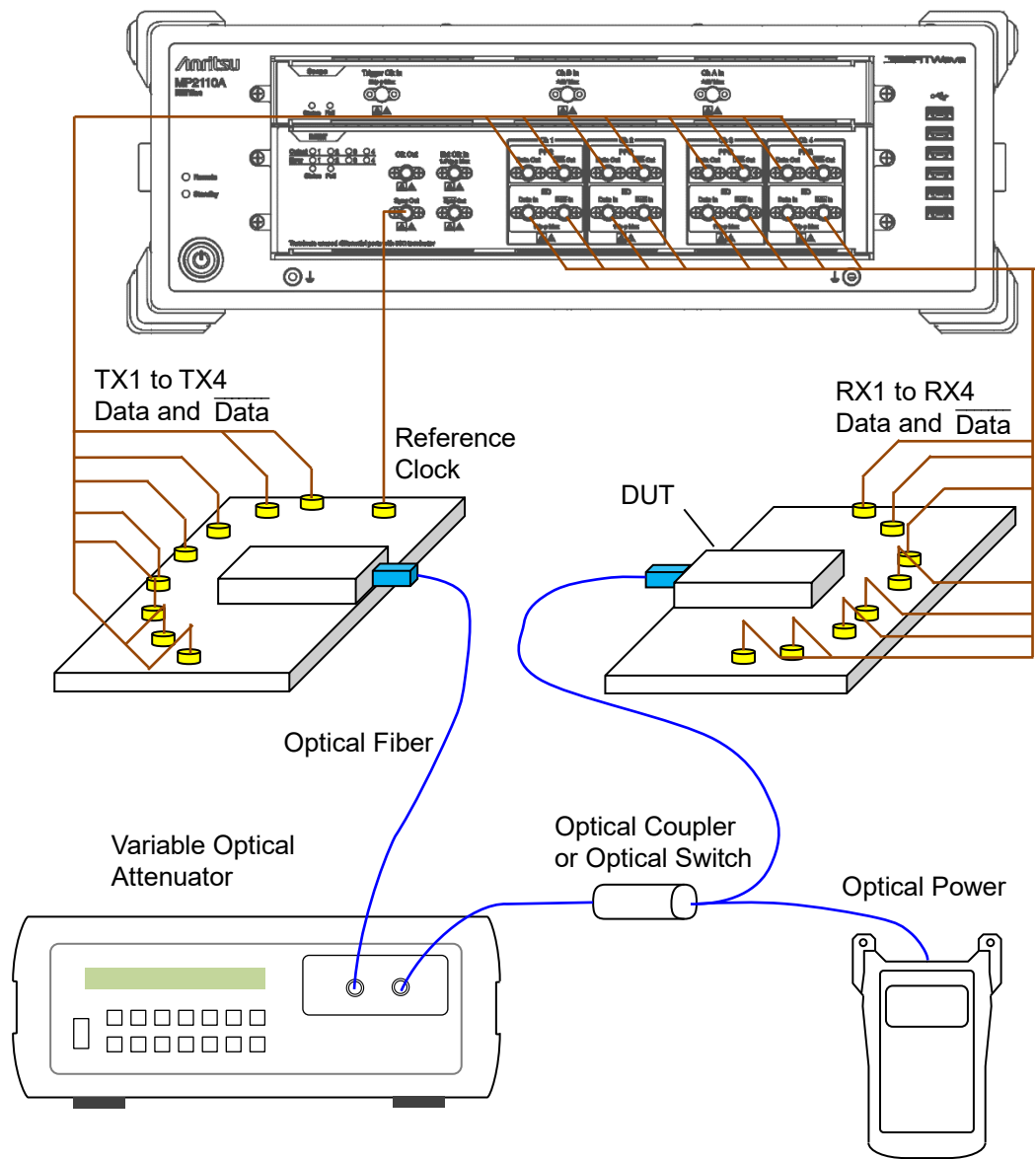

3
Measurement Examples

Figure 3.3-1 Simultaneously Measuring Bit Error Rate for 4 Channels (MP2110A-x14)

1. Connect the PPG1-PPG4 **Data Out** connectors and Input connectors on the CFP4 for transmission using coaxial cables.
2. Connect the PPG1-PPG4 **Data Out** connectors and Input connectors on the CFP4 for transmission using coaxial cables.
3. To use the optional Reference Clock, connect the Reference Clock connector on the CFP4 for transmission and the **Sync Out** connector using a coaxial cable.
4. Connect the DUT CFP4 output connectors and ED1-ED4 **Data In** connectors using coaxial cables.
5. Connect the DUT CFP4 output connectors and ED1-ED4 **Data In** connectors using coaxial cables.
6. Connect the optical output connector of the CFP4 for transmission to the input connector of the variable optical attenuator using an optical fiber.
7. Connect the output connector of the variable optical attenuator to the optical coupler.
8. Connect one end of the optical coupler to the input connector of the DUT CFP4.
9. Connect the other end of the optical coupler to the optical power meter.

An optical switch can be used in place of the optical coupler.



CAUTION

Check that the optical output level input to the CFP4 under test does not exceed the rated optical input level.

There is a risk of damaging the CFP4 module if the optical power exceeding the rated optical input level is applied.

3.3 Measuring Multichannel Optical Module Bit Error Rate

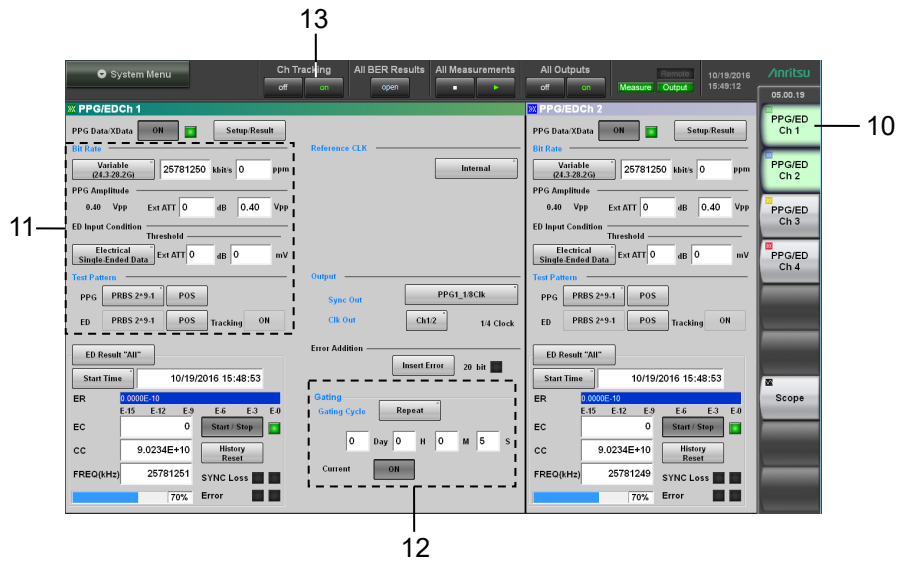

Figure 3.3-2 PPG/ED Settings

10. In the application window, click **PPG/ED Ch1**.
11. Set Bit Rate, PPG Amplitude, ED Input Condition and Test Pattern. Refer to Chapter 5, “How to Operate BERT” for details of the operation method.
12. Set Gating.
13. Change the color of the characters on the button to green by clicking **on** at Ch Tracking.

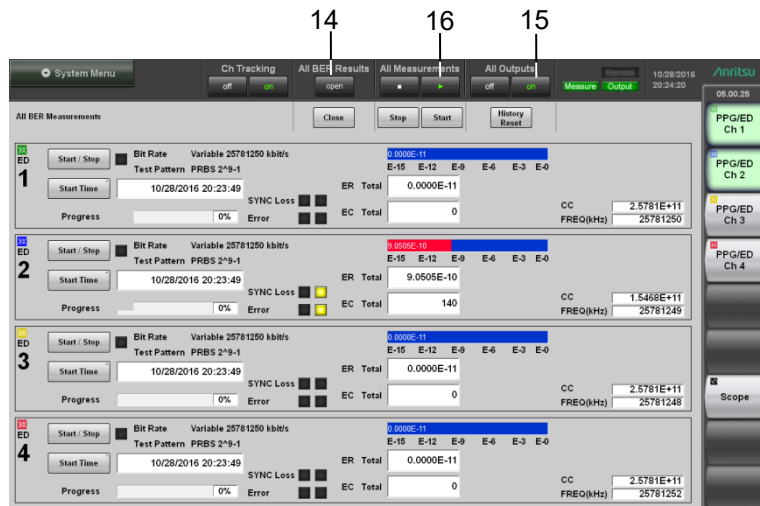

Figure 3.3-3 Measurement of Bit Error Rate

14. Click **open** at All BER Results.

15. Change the color of the characters on the button to green by clicking **on** at All Outputs. Check the following items.
 - The Output lamps 1 to 4 on the BERT panel are lit. (Refer to Figure 2.2.1-3.)
 - In the application window, the SYNC Loss and Error indicators are off.
16. Change the color of the characters on the button to green by clicking **▶** at All Measurements. When the time set at Gating elapses, the measurement values are displayed at ER, EC, CC and FREQ (kHz).

Chapter 4 Screen Operation

This chapter explains the names of screen elements and the operating methods common among the MP2110A.

4.1	Window Configuration	4-2
4.2	Data Input Method	4-5
4.3	Setting System Menu	4-8
4.3.1	Save	4-9
4.3.2	Open.....	4-10
4.3.3	Screen Copy	4-11
4.3.4	Initialize.....	4-12
4.3.5	External Ctrl On	4-12
4.3.6	External Ctrl Off	4-12
4.3.7	Panel Lock.....	4-12
4.3.8	Local/Panel Unlock	4-12
4.3.9	Before Use.....	4-13
4.3.10	Minimize	4-14
4.3.11	Dock/Undock	4-14
4.3.12	Remote Control.....	4-15
4.3.13	System Information	4-17
4.3.14	Exit	4-18
4.4	Multi-channel Signal Output	4-19
4.5	Simultaneous Measurement Start and Stop at Multi-channels.....	4-20
4.6	Linking Measurement Settings for Multiple Channels.	4-21
4.7	Displaying BER Measurement Results for Multiple Channels	4-22
4.8	Displaying Date/Time and Status	4-23

4.1 Window Configuration

Figure 4.1-1 shows the names of elements in the application window and their layout.

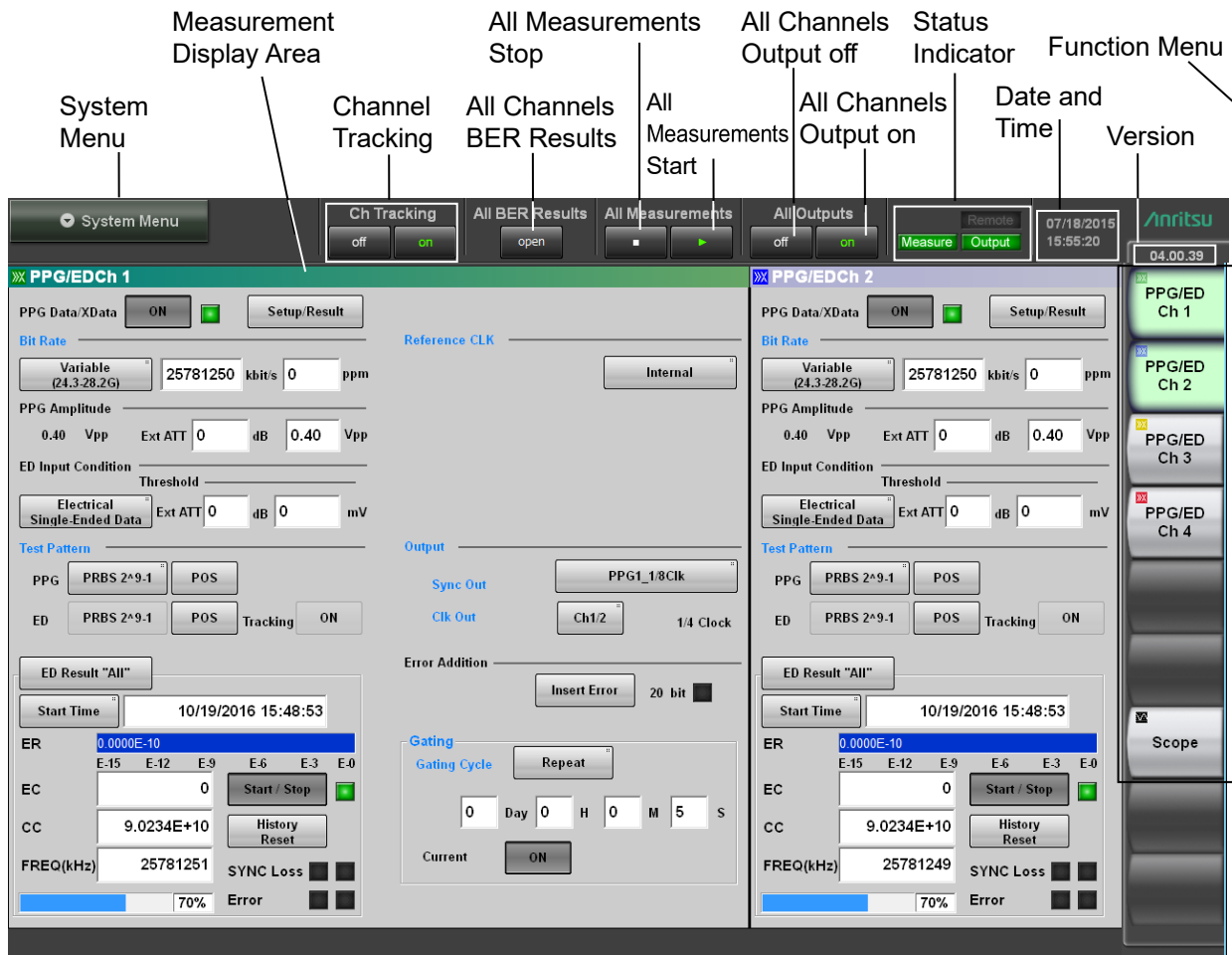

Figure 4.1-1 Names of Application Window Elements

The elements that are set as common in the channels other than Ch 1 are displayed by light blue characters.

Table 4.1-1 Application Screen Elements

Name	Description
All BER Results	Displays the BER measurement results for multiple channels.
All Measurements	Starts and stops up to four channels of error rate measurement (MP2110A-x11, x12, x14) and up to four channels of waveform data (MP2110A-x21 to x49) sampling at the same time.
All Outputs	Sets all PPG (MP2110A-x11, x12, x14) channels output to On/Off at the same time.
Ch Tracking	Sets the bit rate, test pattern, PPG/ED tracking function, and gating for all channels to match the setting for channel 1.
System Menu	Provides the following menu option buttons: <ul style="list-style-type: none"> • Save • Open • Screen Copy • Initialize • External Ctrl On • External Ctrl Off • Panel Lock • Local/Panel Unlock • Before Use • Minimize • Dock/Undock • Remote Control • System Information • Exit
Function menu	Selects the measurement device to be operated. The displayed measurement device varies depending on the options.
Status indicator	The following three kinds of the status are displayed: Remote: Remotely controlled Measure: Measuring bit error rate and obtaining waveform data of sampling oscilloscope Output: Signal output from one of the PPG channels
Measurement display area	Displays the measurement screen selected at the function menu.
Date and Time	Displays date and time set in the MP2110A.
Version display	Displays software version. Displayed in red if the version has not been updated.

The buttons available on the function menu will vary depending on the installed options and software. The following table shows the relation between available buttons and installed options.

Table 4.1-2 Buttons Displayed on Function Menu

Function Menu Button	Option Number				
	MP2110A-x11	MP2110A-x12	MP2110A-x14	MP2110A-x21, x22, x23, x25, x26, x30, x32, x33, x35, x36, x39, x40, x42, x43, x45, x46, x49	MP2110A-x55
PPG/ED Ch1	✓	✓	✓	—	—
PPG/ED Ch2	—	✓	✓	—	—
PPG/ED Ch3	—	—	✓	—	—
PPG/ED Ch4	—	—	✓	—	—
Scope	—	—	—	✓	—
CRU	—	—	—	—	✓*

*: Displayed only when not any scope option but MP2110A-x55 is installed.

Clicking a Function Menu button displays the child window for displaying the measurement conditions and results.

Refer to the following chapters for the child window operations.

PPG/ED: Chapter 5

Scope, CRU: Chapter 6

4.2 Data Input Method

The measurement setting item selection, numeric data, and character data are input from the panel displayed on the screen.

The displayed panel varies depending on the input data types.

Arrow Key Entry Panel

Click the numeric data area when entering the numeric data of the bit rate or power voltage.

The arrow key entry panel as shown in Figure 4.2-1 is displayed.

Click the right and left arrow keys and select the line to change the value.

Click the up and down arrow keys or turn the rotary knob to change the value.

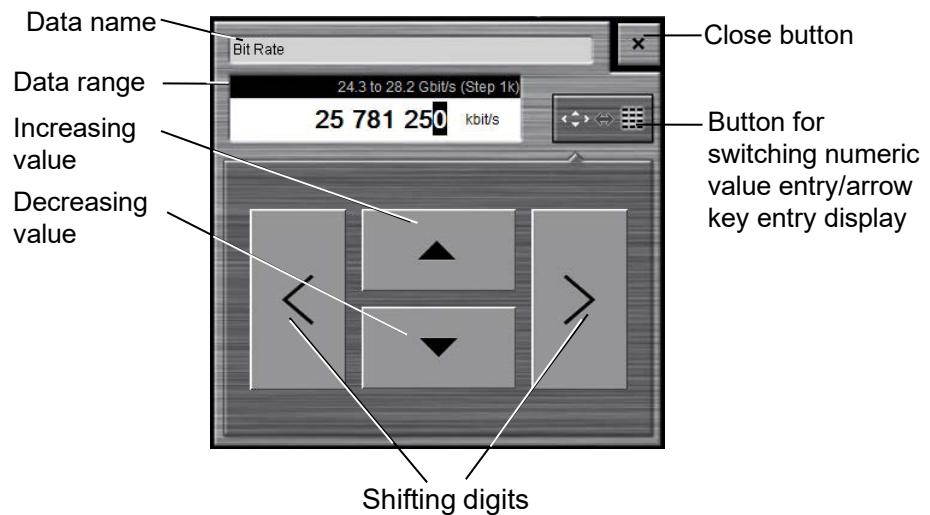

Figure 4.2-1 Arrow Key Entry Panel

Table 4.2-1 lists the key and mouse operations corresponding to the buttons on the arrow key entry panel.

Table 4.2-1 Correspondence between Mouse Operation and Keyboard

Panel Button	Keyboard	Mouse
▲	↑	Turn the mouse wheel up.
▼	↓	Turn the mouse wheel down.
<	←	
>	→	

Numeric value entry panel

Click the button for switching the display of the numeric value entry/arrow key entry panel as shown in Figure 4.2-1, and then the numeric value entry panel as shown in Figure 4.2-2 is displayed. The key type, unit and input range displayed on the panel vary depending on the data.

Click the arrow key entry panel display button, and then the arrow key entry panel as shown in Figure 4.2-1 is displayed.

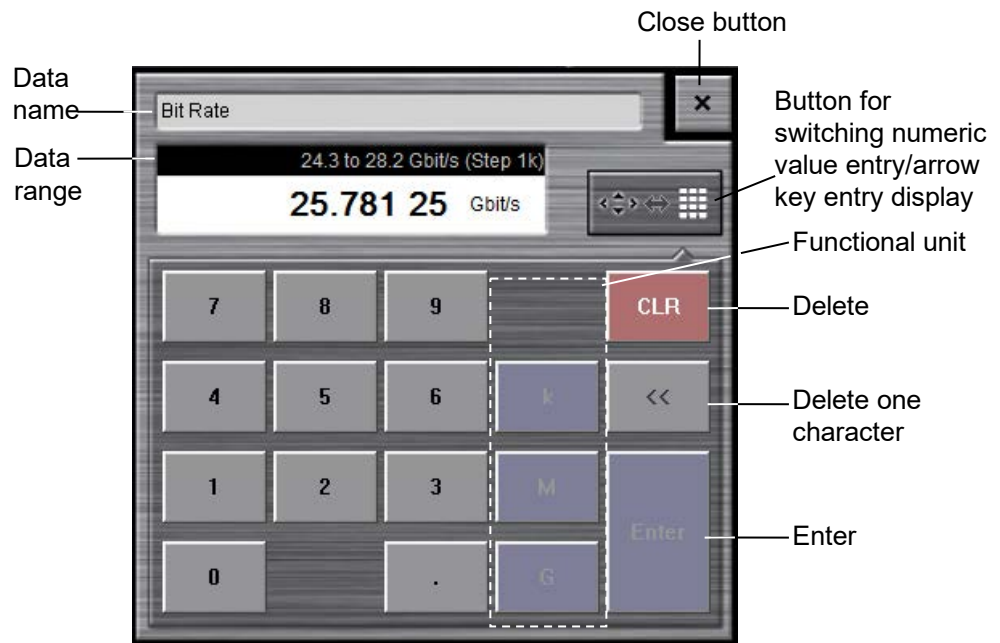

Figure 4.2-2 Numeric Value Entry Panel

Table 4.2-2 lists the keys on the keyboard corresponding to buttons on the numeric value entry panel.

Table 4.2-2 Correspondence between Panel Keys and Keyboard

Panel Key	Keyboard	Panel Key	Keyboard
0	0	.	.
1	1	+/-	-
2	2	CLR	ESC
3	3	<<	BS
4	4	Enter	Enter
5	5		
6	6		
7	7		
8	8		
9	9		

Software Keyboard

When entering character string data such as file name, click **Screen Keyboard**. In the Keyboard screen (Figure 4.2-3), click keys to enter an alphanumeric string. If you click **Shift** or **Caps** once, all keys are locked. To unlock them, click **Shift** or **Caps** again.

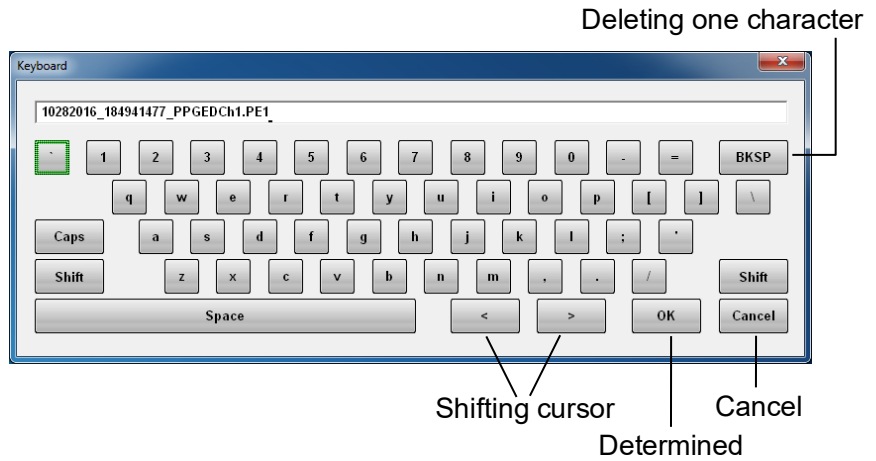

Figure 4.2-3 Software Keyboard

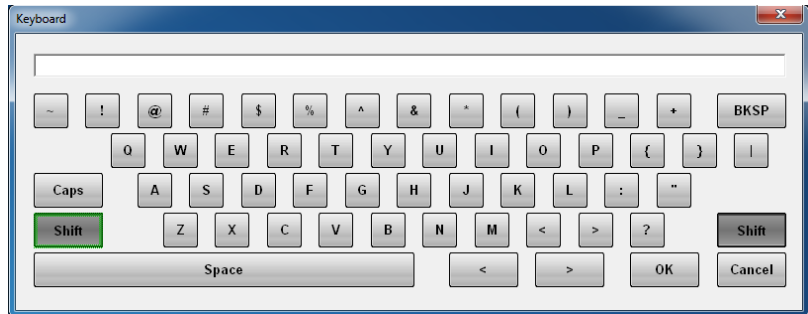

Figure 4.2-4 Software Keyboard (Shift Locked)

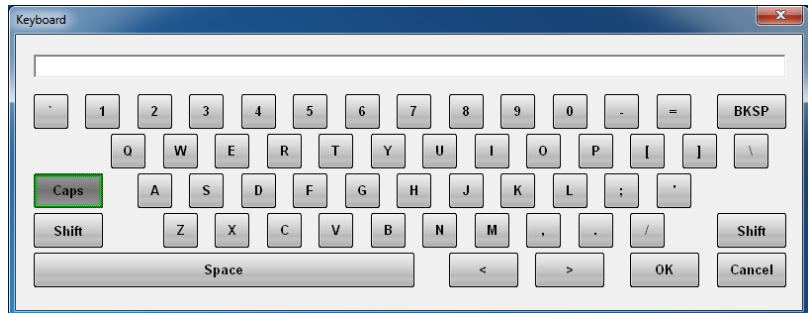

Figure 4.2-5 Software Keyboard (Caps Key Locked)

4.3 Setting System Menu

The following items can be set and confirmed at the system menu.

- Saving measurement conditions and measurement results (Save)
- Loading measurement conditions (Open)
- Saving window image (Screen Copy)
- Initializing device settings (Initialize)
- Turning on external control mode (External Ctrl On)
- Turning off external control mode (External Ctrl Off)
- Setting panel lock (Panel Lock)
- Enabling panel lock and remote display (Local/Panel Unlock)
- Playing back the video of countermeasure against static electricity (Before Use)
- Minimizing screen display (Minimize)
- Setting the application window display position (Dock/Undock)
- Setting remote control (Remote Control)
- Displaying system information (System Information)
- Terminating application (Exit)

To display the system menu, click **System Menu** as shown in Figure 4.1-1.

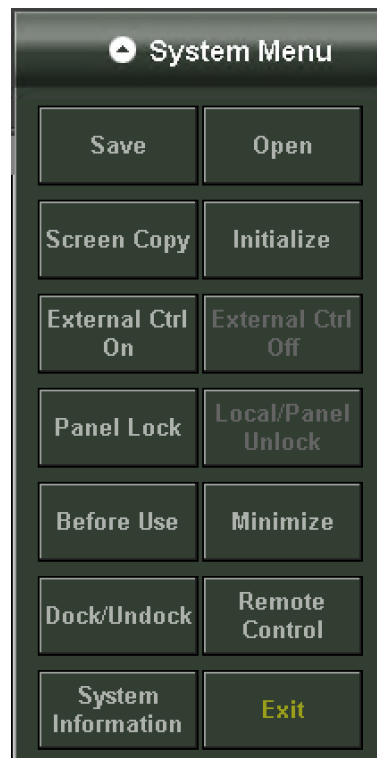
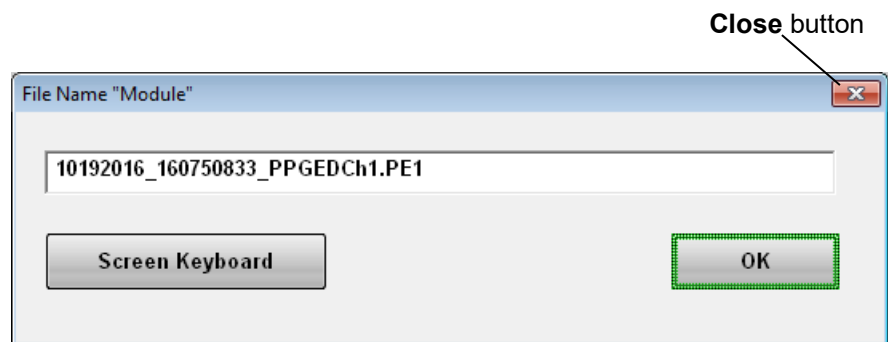

Figure 4.3-1 System Menu

4.3.1 Save

Saving measurement conditions and measurement results

1. Click **Save** to display the Save panel.
2. Select the save data from the following:
PPG/ED Ch 1, PPG/ED Ch 2, PPG/ED Ch 3, PPG/ED Ch 4, Scope, All Setups
The displayed module varies with the options.
3. When **PPG/ED Ch 1, PPG/ED Ch 2, PPG/ED Ch 3, PPG/ED Ch 4, or Scope** is saved, select the data type from the following:
Setting: Measurement conditions
Result: Measurement results
4. The file name is displayed. To edit the displayed default file name, click **Screen Keyboard**.



5. In the Keyboard screen, edit the file name.
6. To save to a file, click **OK**. To cancel saving procedure, click the **Close** button.

Measurement condition files are saved in the following folder:

C:\Users\Public\Documents\Anritsu\MX210000A\UserData\Setting

Measurement result files are saved in the following folder:

C:\Users\Public\Documents\Anritsu\MX210000A\UserData\Result\CSV

C:\Users\Public\Documents\Anritsu\MX210000A\UserData\Result\TXT

CSV files can be load in spreadsheet software.

Text files can be opened in text editor.

4.3.2 Open

Loading measurement conditions from file

1. Click **Open** to display the Open panel.
2. Select the target module form the following:
PPG/ED Ch 1, PPG/ED Ch 2, PPG/ED Ch 3, PPG/ED Ch 4, Scope, All Setups
The displayed module varies with options.
3. The file selection screen is displayed.

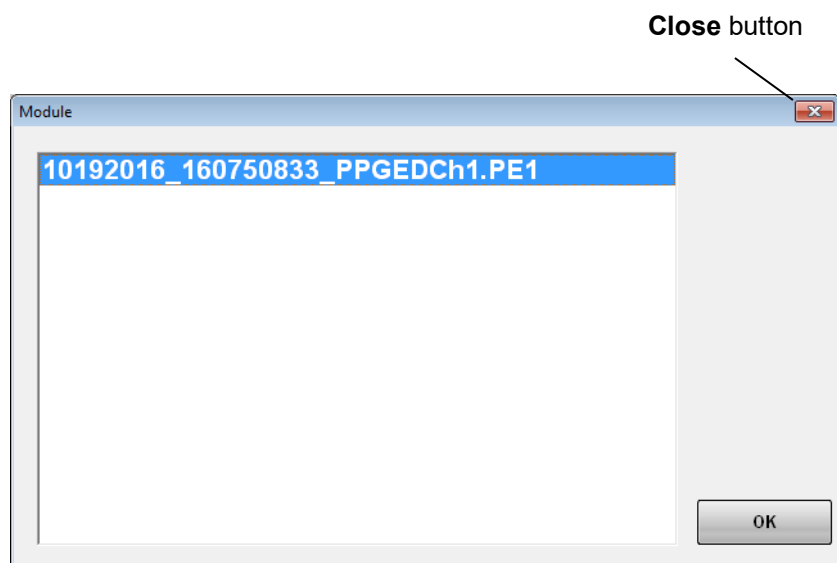

4. Click the file to be load.
5. To load the file, click **OK**. To cancel loading the file, click the **Close** button.

4.3.3 Screen Copy

Saving screenshots as image files

1. Click **Screen Copy**.

The file selection dialog box is displayed.

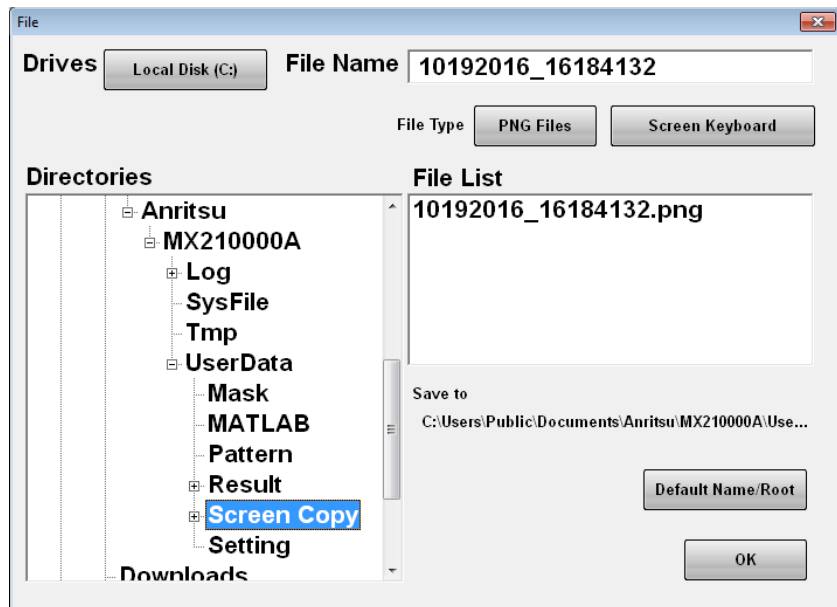

2. Click the **Drives** button, and then in the **Directories** area, select a save destination folder. The folder name is displayed at **Save to**.
3. The file format to be saved is displayed in the right button of the file type. The file format can be toggled between **PNG Files** and **JPEG Files** by clicking the button.
4. To input the file name, click **Screen Keyboard** to set the file name.
5. To overwrite an existing file, click the file name in the **File List** area.
6. Click **OK** to save a screenshot as a file.

When overwriting an existing file, a confirmation message is displayed.

When clicking **Default Name/Root**, the folder and file names are set to the default values.

The default folder is as follows:

C:\Users\Public\Documents\Anritsu\MX21000A\UserData\Screen Copy

The default file name is the date and time.

For example, the name of the file saved at 12:05:55.523 on 17 January 2017 will be as follows:

For **JPEG Files**: 01172017_120555523.jpg

For **PNG Files**: 01172017_120555523.png

4.3.4 Initialize

Initializing measurement conditions

1. Click **Initialize**, and you are asked if you want to initialize all settings.
2. To initialize the measurement conditions, click **OK**. To cancel the initialization, click **Cancel**.

4.3.5 External Ctrl On

This menu turns on external control mode.

Do not use this menu for normal use; keep it turned off.

4.3.6 External Ctrl Off

This menu turns off external control mode.

4.3.7 Panel Lock

Panel locking

Preventing screen operations at other than **System Menu** is called “panel locking”.

1. Click **Panel Lock** to lock the panel.
2. The screen elements other than **System Menu**, status indicators, and date and time display are shaded.

Even if the panel is locked, **System Menu** and the power switch are available.

When the panel is locked, **Local/Panel Unlock** in **System Menu** is available.

When the MP2110A is remotely controlled, the panel is locked.

4.3.8 Local/Panel Unlock

Unlocking the panel

1. Click **Local/Panel Unlock**.
2. The **Remote** status indicator turns off.

4.3.9 Before Use

Playing back the video of countermeasure against static electricity

Click **Before Use**.

Other window is displayed and the video of countermeasure against static electricity is played back in the window.

The playback time is about 1 minute 40 seconds.

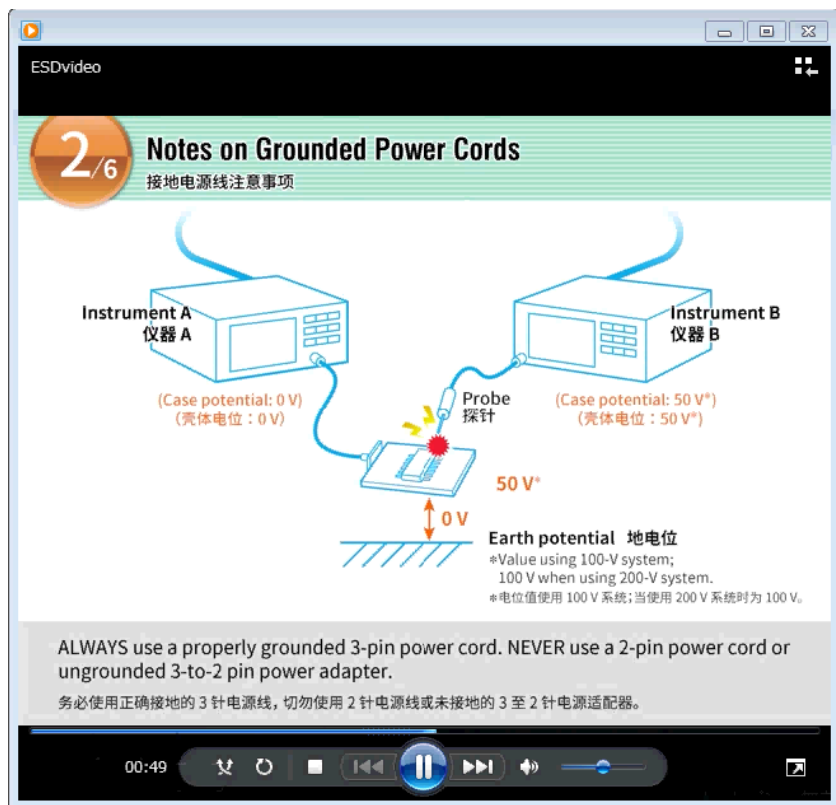

Figure 4.3.7-1 Display Window for Video of Countermeasure Against Static Electricity

4.3.10 Minimize

Minimizing the screen display

1. Click **Minimize** to display the desk top.
MX210000A is displayed on the task bar.
2. To display the screen, click **MX210000A** on the task bar.

4.3.11 Dock/Undock

Changing the window display method

Click **Dock/Undock**.

At Dock, the window is fixed at the upper left of the screen, and the window cannot be moved. This setting allows the application window to display in full screen when the monitor resolution is 1280 × 800. Refer to 2.9.3 “Setting External Monitor”.

At Undock, the window can be moved.

4.3.12 Remote Control

Clicking **Remote Control** displays the following dialog box.

Figure 4.3.10-1 Remote Control Dialog Box

To set GPIB

1. Click the GPIB Address text box. A dialog box for inputting the address is displayed.
2. Enter the GPIB address in the range of 0 to 30.
3. To complete the setting, click **OK**.
To cancel the setting, click **Cancel**.

To set Ethernet

1. Click the Port Number text box of Raw Socket. A dialog box for inputting the port number is displayed.
2. Set the number in the following range:
Port Number: 1024 to 5001

3. Click **Change Network Connections** to change the IP address, subnet mask, and gateway address of the MP2110A. The Windows Network Connections window is displayed.

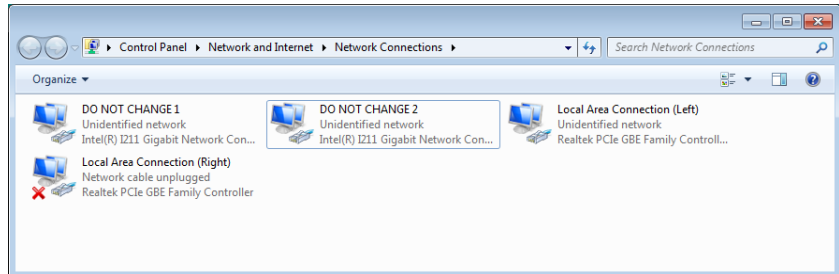

4. Right-click the **Local Area Connection (Left)** or **Local Area Connection (Right)** icon, and click **Properties**.
5. Click **Internet Protocol Version 4 (TCP/IPv4)**, and click **Properties**.
6. In the **Internet Protocol Version 4 (TCP/IPv4) Properties** dialog box, configure the settings.

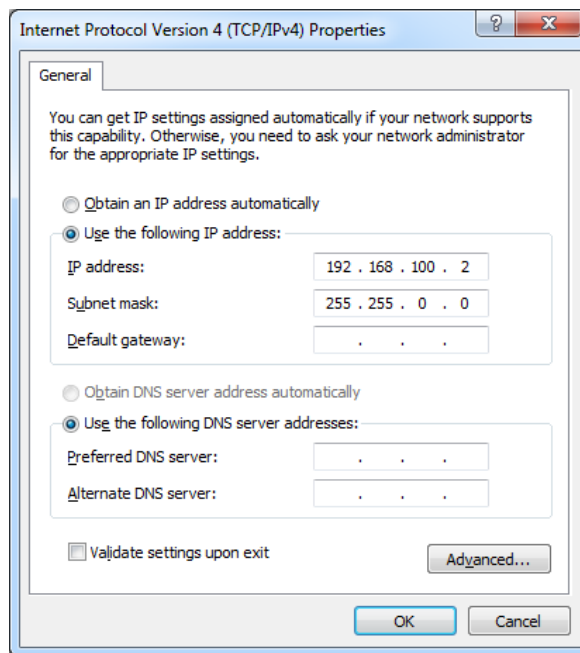

To automatically obtain an IP address of Local Area Connection using DHCP, click **Obtain an IP address automatically**.

7. Click **OK** to complete the settings.
Click **Cancel** to cancel the settings.

Note:

At step 3, do not change the setting of DO NOT CHANGE (Intel(R) Gigabit Network Controller) in the **Network Connections** dialog box. If changed, the application is not started correctly. If this setting is changed, set **Obtain an IP address automatically** and **Obtain DNS server address automatically** at step 6.

4.3.13 System Information

Displaying the system information

Click **System Information**. The **System Information** dialog box appears.

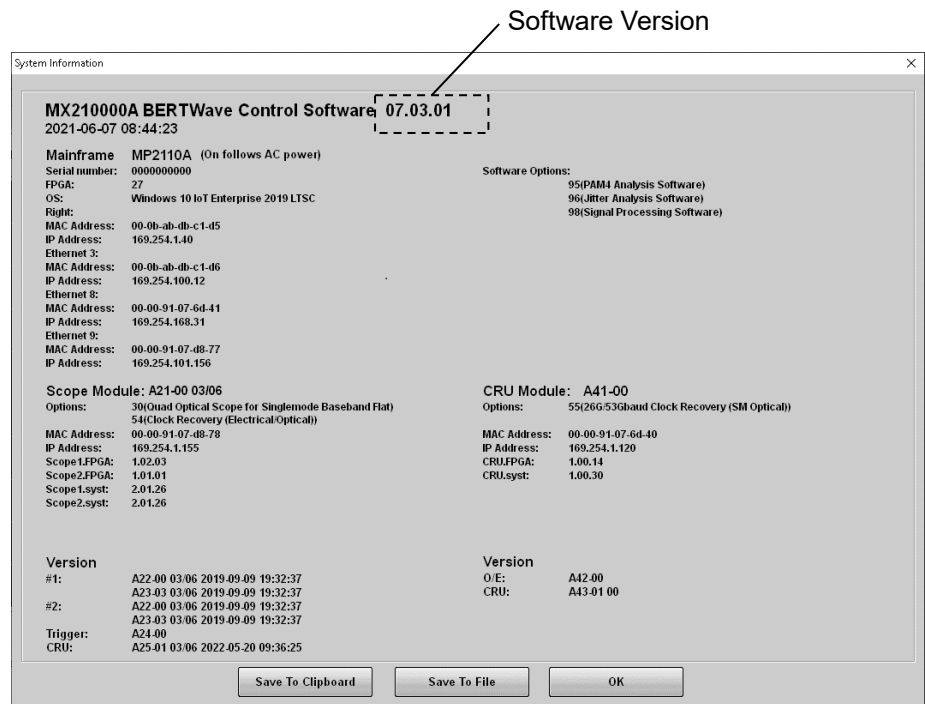
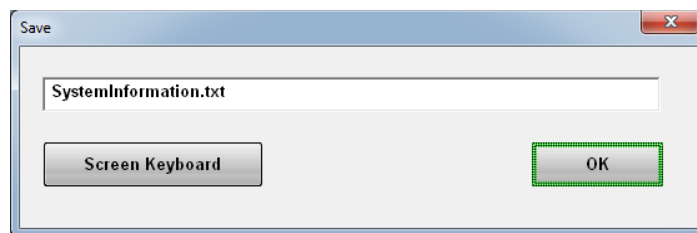

Figure 4.3.11-1 System Information Dialog Box

Click **Save To Clipboard** to copy the system information to the Windows clipboard.

Click **Save To File** to open the **Save** dialog box. Enter the file name and click **OK** to save the system information to a file.



Click **Exit** to close the **System Information** dialog box.

4.3.14 Exit

Terminating application

1. Click **Exit**. You will see the dialog box asking if you want to terminate the application.
2. To terminate the application, click **Yes**.
To cancel the application termination, click **No**.

To restart the application:

- Double-click the **MX210000A** icon.
or
- On the **Start** menu, point to **All Programs, Anritsu**, and then click **MX210000A**.

4.4 Multi-channel Signal Output

The MP2110A can set PPG channels 1 to 4 to On/Off at the same time.

To output signal from PPG:

1. Click **on** at **All Outputs** shown in Figure 4.4-1.
2. The letters of **on** turn green and then the **Output** status indicator turns green.

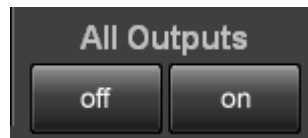

Figure 4.4-1 All Outputs Button

Signals are output from all channels of PPG.

To stop the signal output from the PPG:

1. Click **off** at **All Outputs** shown in Figure 4.4-1.
2. The characters of **on** are changed to white and then the **Output** status indicator turns off.

The data signal output is stopped for all the PPG channels 1 to 4.

Note:

When you start the MX210000A, **off** is set for **All Outputs**.

4.5 Simultaneous Measurement Start and Stop at Multi-channels

The MP2110A can measure error rates for up to four channels and sample waveform data for up to four channels simultaneously.

To start simultaneous measurement, click the ► key shown in Figure 4.5-1. The **Measure** status indicator turns green.

To stop simultaneous measurement, click the ■ key shown in Figure 4.5-1. The **Measure** status indicator turns off.

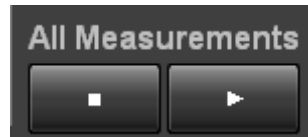

Figure 4.5-1 All Measurements Button

4.6 Linking Measurement Settings for Multiple Channels

With the MP2110A-x14, **Ch Tracking** is displayed in the application screen.

To apply the PPG and ED settings for Ch1 to other channels, click **on**. In this state, altering settings for Ch1 also alters the settings for other channels.

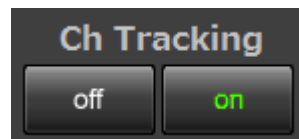

Figure 4.6-1 Ch Tracking

The following settings are linked:

- Test Pattern
- ED Tracking*
- ED Gating Cycle (Repeat/Single/Untimed)
- ED Gating Period

*: Setting Ch Tracking to **on** sets ED Tracking to On. However, setting Ch Tracking to **off** does not set ED Tracking to Off.

4.7 Displaying BER Measurement Results for Multiple Channels

With the MP2110A-x14, **All BER Results** is displayed in the application screen.

To view BER measurement results for all channels, click **Open**.

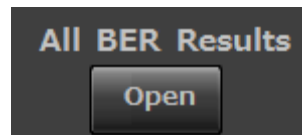

Figure 4.7-1 All BER Results



Figure 4.7-2 All BER Results Display

Table 4.7-1 All BER Measurements Buttons

Name	Description
Start	Starts BER measurement for all channels. The sampling oscilloscope measurement is not started.
Stop	Stops BER measurement for all channels. The sampling oscilloscope measurement is not stopped.
History Reset	Resets the History lamps for all channels.
Close	Closes the All BER Results display.

Clicking the function button of the top menu closes the All BER Results display.

4.8 Displaying Date/Time and Status

To display date and time

Date and time are displayed on the upper right side of the screen.

Date and time can be changed in the Windows Control Panel.

To display status

The following three kinds of indicators indicate the status.

Table 4.8-1 Status Indicators

Indicator	Status
Remote	Turns blue when the MP2110A is being remotely controlled.
Measure	Turns green when measuring bit error rate or acquiring waveform data of sampling oscilloscope.
Output	Turns green when a signal is being output from one of the PPG channels.

4

Screen Operation

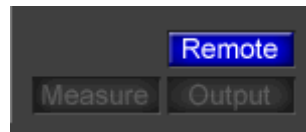

Figure 4.8-1 Status Indicators During Remote Control

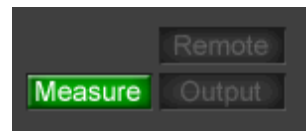

Figure 4.8-2 Status Indicators During Bit Error Rate Measurement and Waveform Data Capture

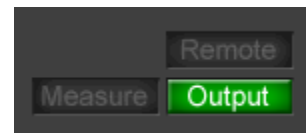

Figure 4.8-3 Status Indicators When PPG Signal is Output

Chapter 5 *How to Operate BERT*

This chapter explains the BERT module setting items and how to measure the bit error.

5.1	Procedure for Generating Pulse Signal	5-2
5.2	PPG/ED Panel	5-3
5.2.1	Setting Reference Clock.....	5-7
5.2.2	Setting Bit Rate.....	5-8
5.2.3	Setting Patterns	5-10
5.2.4	Setting Output Waveform	5-13
5.2.5	Setting Sync Out.....	5-14
5.2.6	Setting Clk Out	5-16
5.2.7	Inserting Bit Error.....	5-17
5.2.8	Setting Error Detection Method	5-18
5.2.9	Setting ED Measurement Condition	5-22
5.2.10	Measurement Result	5-25
5.2.11	Saving Measurement Results	5-26
5.3	Setting Restrictions	5-28

5.1 Procedure for Generating Pulse Signal

The basic procedure is as shown in the following figure.

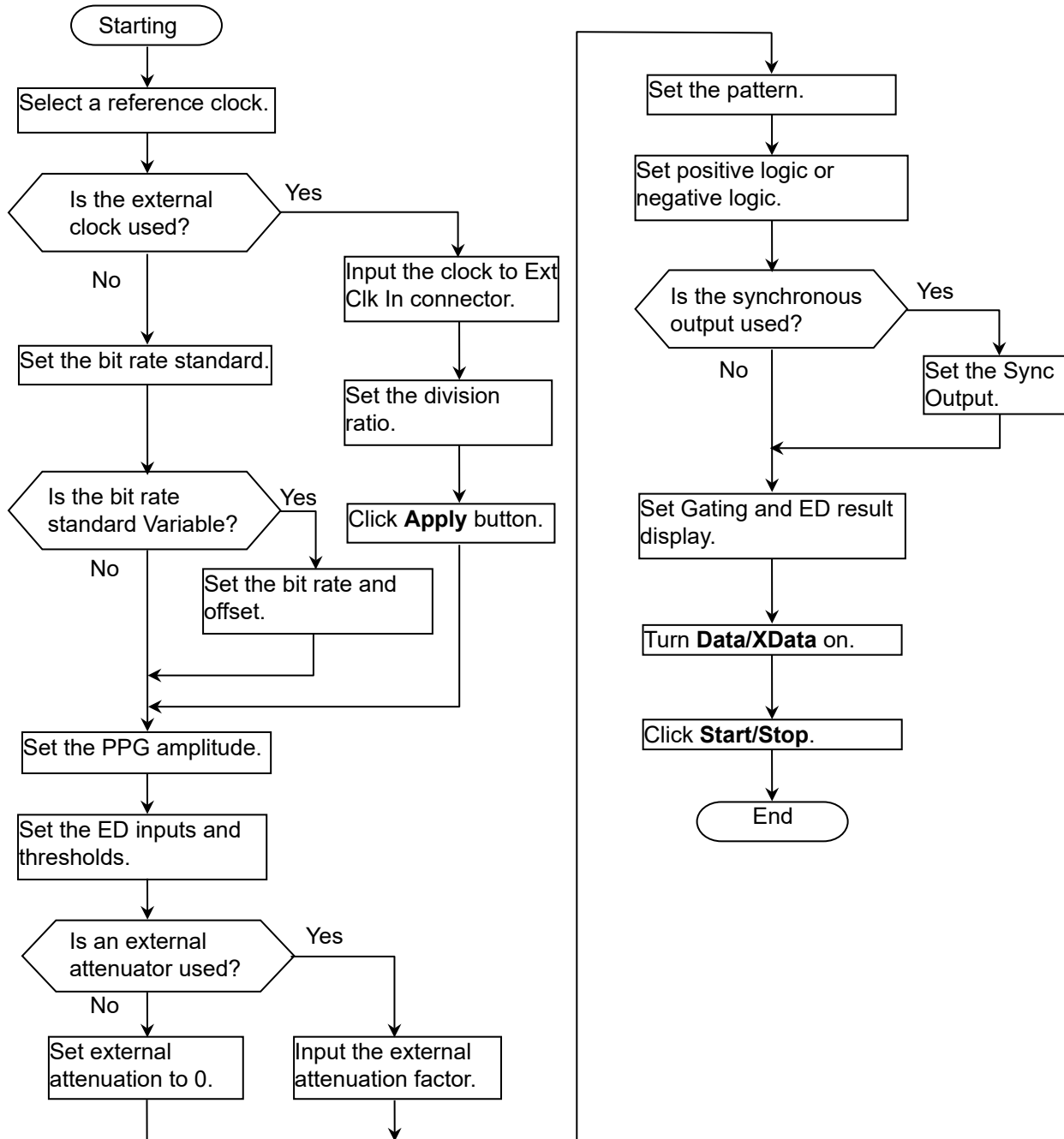

Figure 5.1-1 Basic Procedure of Generating Pulse Signal

5.2 PPG/ED Panel

Clicking **PPG/ED Ch1** of the function key displays the following panel. The elements that are set as common in the channels other than Ch 1 are displayed by the light blue characters.

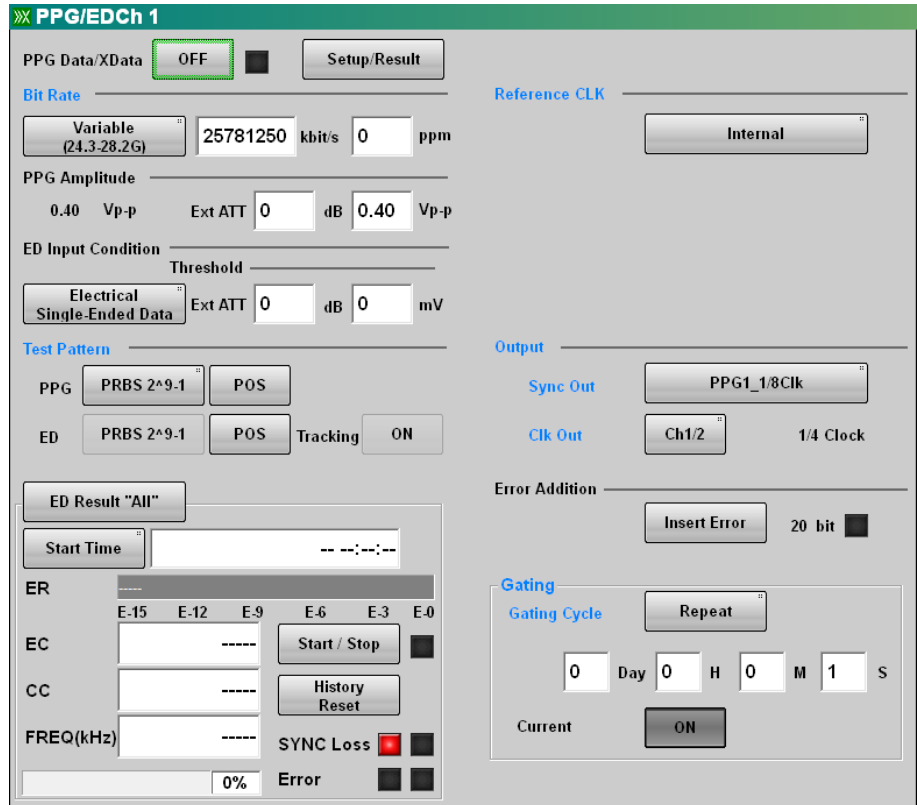

Figure 5.2-1 PPG/ED Settings Panel

Figure 5.2-2 shows the bit rate display when setting **Ext Clk In** at **Reference CLK**.

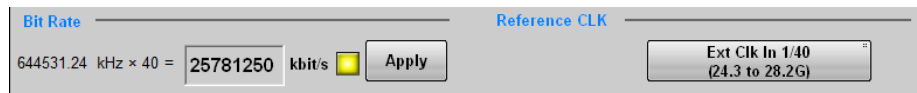

Figure 5.2-2 Bit Rate Display When Setting Ext Clk In

When **Setup/Result** is clicked, the panel display is changed to the panel shown in Figure 5.2-3. And when **Setup/Result** is clicked again, the panel display is changed to the panel shown in Figure 5.2-1.

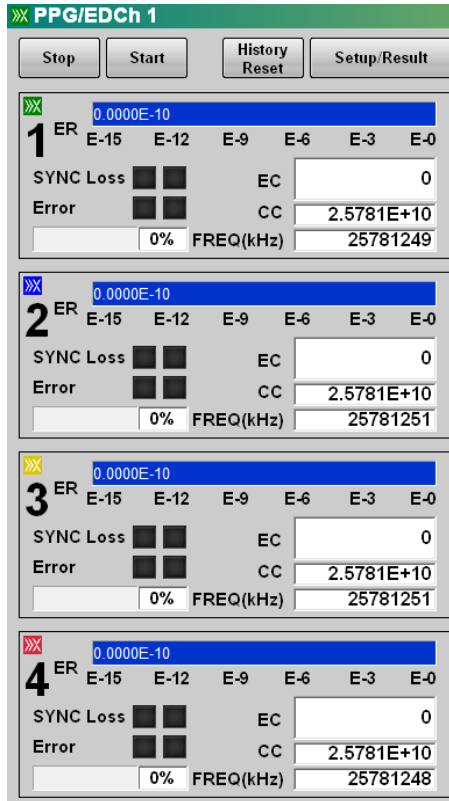

Figure 5.2-3 PPG/ED Results Panel (In case of MP2110A-x14)

The following table describes the panel.

Table 5.2-1 Setting Items of PPG/ED

Item	Description
Setup/Result	Switches the PPG/ED panel display.
PPG Data/XData	Sets the PPG data signal output On/Off. XData means $\overline{\text{Data}}$ on the front panel. The right side of the button is lit in green while the data is outputting to the connector.
Bit Rate*1	When Reference CLK is Internal : Select the communication standards by clicking the button. Set the bit rate when Variable is selected. Set the offset in the range from -100 to 100 ppm for the set bit rate. When Reference CLK is Ext Clk In : Input the external clock and check that the indicator of the Reference CLK status display is changed to yellow, then click Apply . When the internal pattern generation circuit is synchronized with the external clock, the external clock frequency and bit rate are displayed.
Reference CLK Status Display	Displays the reference clock synchronization status. Red: Reference clock cannot be detected. Yellow: Reference clock was detected, but is not synchronized with pattern data. Green: Reference clock is synchronized with pattern data.
PPG Amplitude	Sets the amplitude voltage of the signal output to the Data Out connector and $\overline{\text{Data Out}}$ connector at the text box on the right. When the attenuators are connected to the Data Out connector and $\overline{\text{Data Out}}$ connector, set the attenuation at Ext ATT. The amplitude voltage of the signal output from the attenuator is displayed. Note: Connect the attenuators that are the same attenuation to the Data Out connector and $\overline{\text{Data Out}}$ connector.
ED Input Condition	Selects the input method of ED by clicking the button. Set the threshold voltage of the Data In connector and $\overline{\text{Data In}}$ connector at the text box on the right. When the attenuators are connected to the Data In connector and $\overline{\text{Data In}}$ connector, set the attenuation at Ext ATT. Note: Connect the attenuators that are the same attenuation to the Data In connector and $\overline{\text{Data In}}$ connector.

*1: This is set to the following channels as common:

In MP2110A-x12: Ch 1 and Ch 2

In MP2110A-x14: Ch 1 to Ch 4

Table 5.2-1 Setting Items of PPG/ED (Cont'd)

Item	Description
Test Pattern* ²	<p>Selects the test pattern by clicking the button.</p> <p>The polarity of test pattern can be changed by clicking POS or NEG.</p> <p>The polarity when the test pattern is “1” is shown below:</p> <p>POS: The voltage of Data connector is higher than the voltage of Data connector.</p> <p>NEG: The voltage of Data connector is higher than the voltage of Data connector.</p> <p>Set ON at Tracking to set the same test pattern to PPG and ED.</p>
ED Result	Sets the method for displaying the bit error measurement results.
Start Time	Displays the start time of the bit error measurement.
Elapsed Time	Displays the elapsed time of the bit error measurement.
Remaining Time	Displays the remaining time calculated by subtracting the elapsed time of the bit error measurement from the time set at Gating .
Start/Stop	Stops/starts bit error rate measurement.
History Reset	Deletes the history displays of Sync Loss and Error.
Reference CLK* ¹	<p>Selects the clock to be used from the following items:</p> <p>Internal: Use the internal clock based on the internal 10 MHz oscillator.</p> <p>Ext Clk In: Use the external clock input from the Ext Clk In connector.</p>
Sync Out* ¹	Selects the clock source and division ratio for the signal output to the Sync Out and Sync Out connector
Clk Out* ¹	Selects the clock source for the signal output to the Clk Out connector.
Error Addition	When Insert Error is clicked, bit errors are inserted in the test pattern, and the indicator on the right is lit in red for one second.
Gating Cycle* ²	<p>Selects the bit error measurement method by clicking the button.</p> <p>Set the time of single bit error measurement.</p>
Current	Setting On updates the results display while BER measurement is in progress.

*2: This is set as common in Ch 1 to Ch 4 when Ch Tracking is **on** in MP2110A-x14.

5.2.1 Setting Reference Clock

BERT uses the reference clock to generate the data and detect an error. The reference clock can be selected from the following supply sources:

- Internal clock generated inside the MP2110A
- External clock input from the **Ext Clk In** connector

The internal clock accuracy is ± 10 ppm after power is applied for 1 hour.

The external clock is used under the following conditions:

- When synchronizing other equipment with clock
- When using clock with higher accuracy than internal clock

Table 5.2.1-1 Reference CLK Settings

Reference CLK	Description	Frequency of Clock Input to Ext Clk In (MHz)
Internal	Use the internal clock based on the internal 10 MHz oscillator	
Ext Clk 1/16*	Use the external clock input from the Ext Clk In connector When the bitrate is within 9.5 to 14.2 Gbit/s The division ratio of external clock frequency and bit rate is 16.	593.75 to 887.5
Ext Clk 1/40	Use the external clock input from the Ext Clk In connector When the bitrate is within 24.3 to 28.2 Gbit/s The division ratio of external clock frequency and bit rate is 40.	607.5 to 705.0

*: This is displayed when MP2110A-x93 is installed.

Note:

Click **Apply** when the Reference CLK status display is lit in yellow while the external clock is used.

The **Ext Clk In** connector is an AC coupling.

Input the signal of the sine wave or square wave where the amplitude is 0.2 to 1.6 V_{p-p}.

5.2.2 Setting Bit Rate

Set the bit rate when Reference CLK has been set to **Internal**.

The bit rate is set as common in PPG/ED Ch 1 to Ch 4. For example, when the bit rate is changed in the PPG/ED Ch1 panel, the bit rates of PPG/ED Ch2 to PPG/ED Ch4 are also changed.

1. Click the Bit Rate button.

The window is opened to select the standards.

The number of displayed buttons varies depending on whether MP2110A-x93 is added or not.

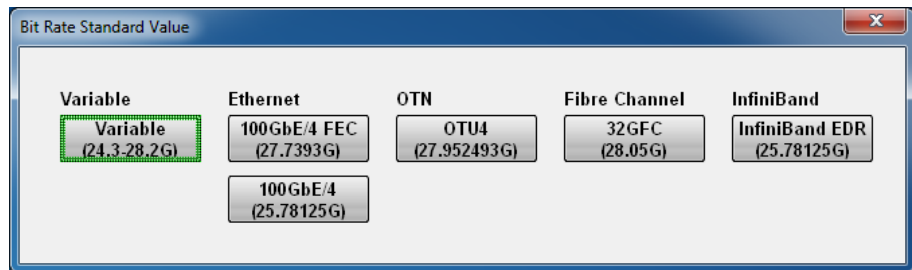

Figure 5.2.2-1 Bit Rate Standard Value Dialog Box (Without MP2110A-x93)

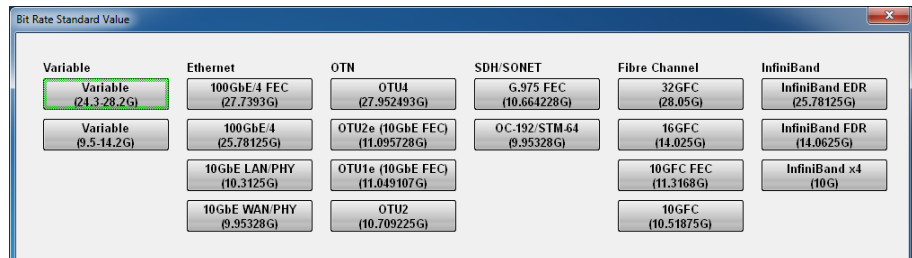

Figure 5.2.2-2 Bit Rate Standard Value Dialog Box (With MP2110A-x93)

2. Click the bit rate standards button.

The number displayed in the button is the specified bit rate (bit/s).

When indicating 28.05G, this means 28.05 Gbit/s.

3. When selecting **Variable**, click the bit rate and offset text boxes and input the value. The bit rate can be set in the range 24.3 to 28.2 GHz, and the offset can be set in the range –100 to 100 ppm.

When MP2110A-x93 is installed, the offset can also be set in the range 9.5 to 14.2 GHz.

Setting Amplitude

1. Click the PPG Amplitude text box and set the amplitude voltage.
2. When the attenuators are inserted between the **Data Out** connector and **Data Out** connector of MP2110A and the DUTs, click the Ext ATT text box and input the attenuation. The amplitude voltage after passing through the attenuator is displayed.



CAUTION

When inserting attenuator at both the Data Out connector and **Data Out** connector, use an attenuator with the same amount of attenuation.

If the attenuation amounts are different, the displayed amplitude and the amplitude output at the connector will be different.

5.2.3 Setting Patterns

The following three test patterns can be selected.

- PRBS
- 1/2 Clock Pattern
- 1/16 Clock Pattern

PRBS

PRBS is the pattern generated at the hardware.

The generated pattern length, maximum length of contiguous 1s, and maximum length of contiguous 0s differ depending on the hardware configuration.

The following block diagram indicates the hardware generating PRBS 2^7-1 .

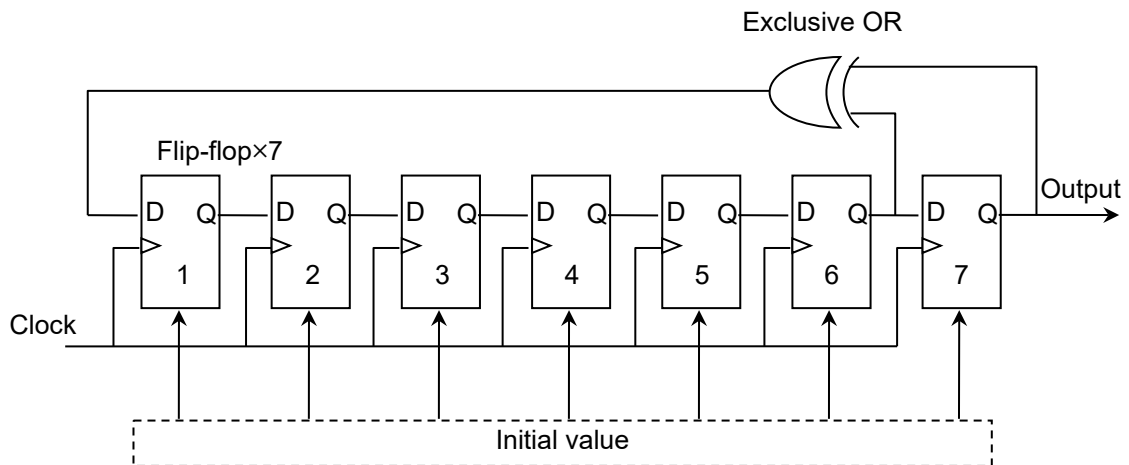

Figure 5.2.3-1 Block Diagram for PRBS Generating Circuit

This block diagram is composed of a shift register composed of a seven-stage flip-flop and an Exclusive OR circuit. A signal of the sixth and seventh stages of the shift register are input to the Exclusive OR and the output of the Exclusive OR is input to the shift register. This type of configuration is described by the following pattern generation polynomial.

$$1 + X^6 + X^7$$

When inputting the default value of 7 bits and impressing the clock, a pattern with a bit length of $2^7-1 = 127$ is repeatedly generated. The default value of seven bits includes 1 or more “1” bits.

The following shows the pattern length, maximum number of contiguous 1s, and maximum number of contiguous 0s using the PRBS generation formula of the MP2110A.

PRBS	Pattern Generation Polynomial	Pattern Length	Maximum number of contiguous 1s	Maximum number of contiguous 0
2^7-1	$1+X^6+X^7$	127	7	6
2^9-1	$1+X^5+X^9$	511	9	8
$2^{15}-1$	$1+X^{14}+X^{15}$	32767	15	14
$2^{23}-1$	$1+X^{18}+X^{23}$	8388607	23	22
$2^{31}-1$	$1+X^{28}+X^{31}$	214748647	31	30

The ratio of 1s to the PRBS pattern length is 50%.

1/2 Clock Pattern

“1/2 Clock Pattern” means the repeating pattern of “1” and “0”.

The pattern of which the clock frequency is divided in half is output from the **Data Out** connector and $\overline{\text{Data Out}}$ connector.

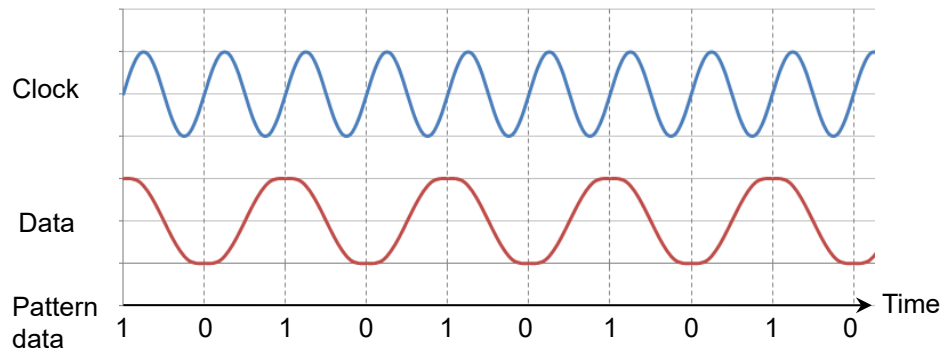

Figure 5.2.3-2 Relationship between Data and Clock when 1/2 Clock Pattern is set

1/16 Clock Pattern

“1/16 Clock Pattern” means the repeating pattern of “11111111” and “00000000”.

The pattern of which the clock frequency is divided in one-sixteen is output from the **Data Out** connector and $\overline{\text{Data Out}}$ connector.

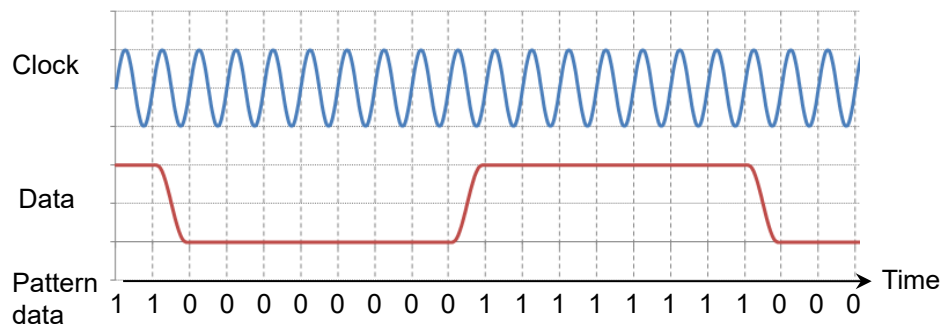

Figure 5.2.3-3 Relationship between Data and Clock when 1/16 Clock Pattern is set

Pattern Logic

There are two types of logic: Positive Logic (POS) and Negative Logic (NEG).

With positive logic, the voltage at the Data connector goes High when the data is “1”.

With negative logic, the voltage at the Data connector goes Low when the data is “1”.

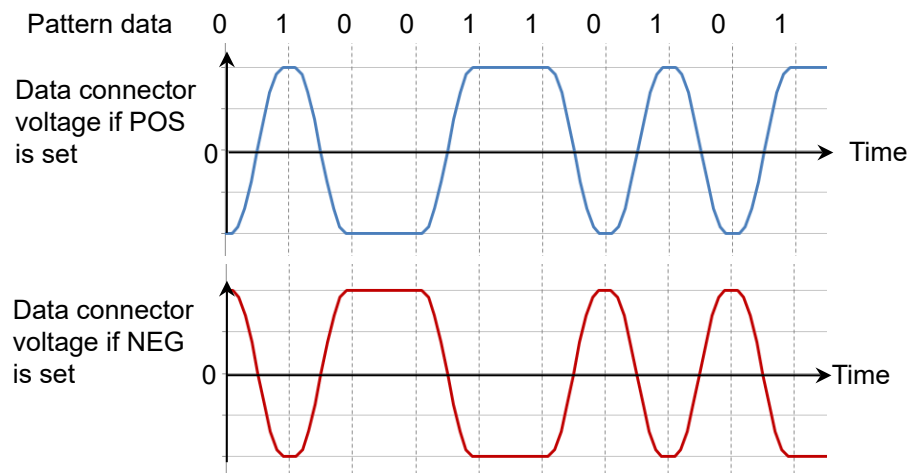
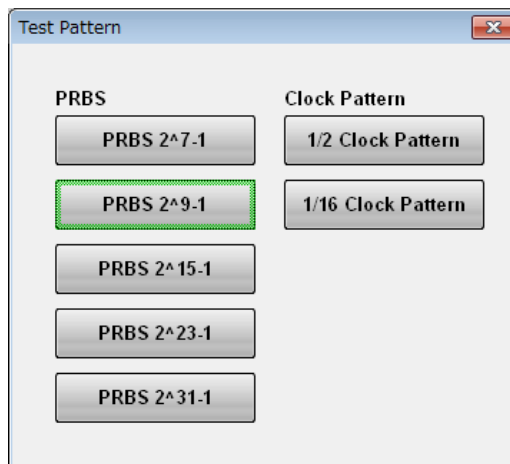

Figure 5.2.3-4 Relationship between Logic Setting and Output Voltage Waveform at Connector

Set the pattern using the following procedure.

1. Click the button for Test Pattern, and you will see the Test Pattern dialog box.



2. Click the button for the pattern you want to set.

5.2.4 Setting Output Waveform

The PPG **Data** connector and $\overline{\text{Data}}$ connector are AC coupling. When it is necessary to impose DC voltage on an output waveform, connect a bias-T.

CAUTION

- The impedance of the Data Out and $\overline{\text{Data}}$ Out connectors is 50 Ω . Measurement may not be performed correctly if a coaxial cable with another impedance is used or if the impedance of the DUT is not 50 Ω .
- The amplitude of signal output to the Data Out and $\overline{\text{Data}}$ Out connectors is 0.1 to 0.8 Vp-p. Check that the output voltage amplitude does not exceed the DUT maximum input specifications. If it does, connect an attenuator to the output connector.

Set the bit rate and amplitude of the waveform output to the $\overline{\text{Data}}$ and **Data** connectors.

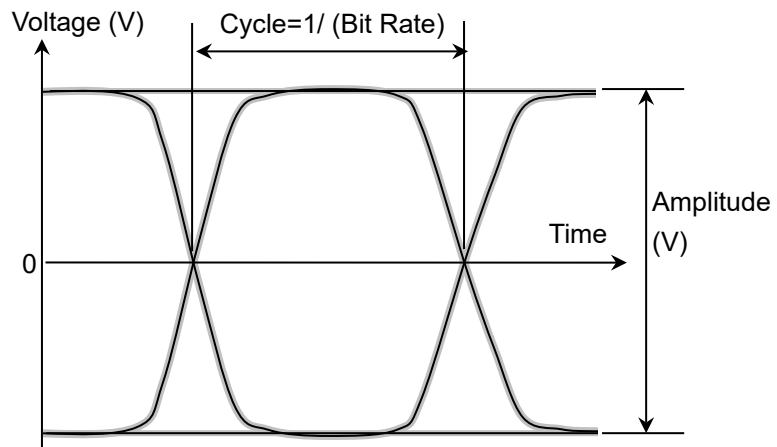

Figure 5.2.4-1 Waveform Setting Item

5.2.5 Setting Sync Out

Set the signal type output from the front-panel **Sync Out** connector.

Sync Out connector outputs a clock synchronized to the data generated by the PPG. The **Sync Out** Connector is a DC coupling.

To monitor the waveform pattern of the pulse pattern generator, set

Pattern Sync at Sync Out and connect the **Sync Out** connector and the

Trigger Clk In connector of the sampling oscilloscope using a coaxial cable.

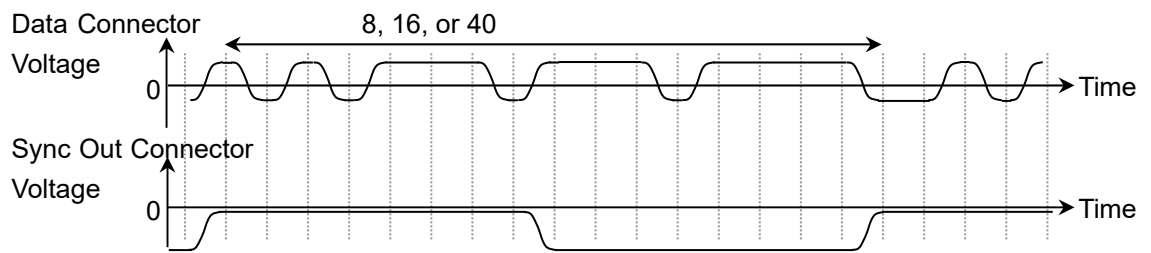

Figure 5.2.5-1 Correspondence between Sync Output Setting and Output Voltage Waveform at Connector Using PPG Rate Division

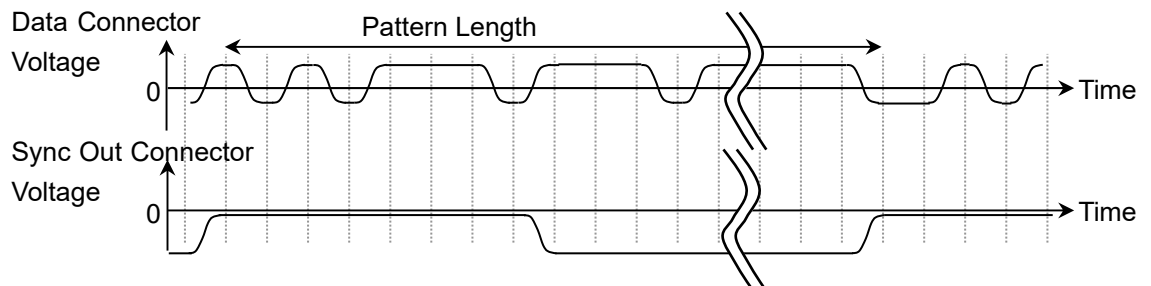

Figure 5.2.5-2 Voltage Waveform Output to Connector Corresponding to Sync Output Setting for Pattern Sync

The Sync Output amplitude cannot be set.

The time interval outputting the pulse varies depending on the pattern length and bit rate when Sync Output is Pattern Sync .

Select the pattern for the measurement referring to Table 5.2.5-1.

Table 5.2.5-1 Cycle of Sync Output (Pattern Sync)

Pattern Name	Bit Rate (kbit/s)			
	10 000 000	14 025 000	25 781 250	28 050 000
PRBS 2 ⁷ -1	12.7 ns	9.1 ns	4.9 ns	4.5 ns
PRBS 2 ⁹ -1	51.1 ns	36.4 ns	19.8 ns	18.2 ns
PRBS 2 ¹⁵ -1	3.28 μs	2.34 μs	1.27 μs	1.17 μs
PRBS 2 ²³ -1	838.9 μs	598.1 μs	325.4 μs	299.1 μs
PRBS 2 ³¹ -1	214.7 ms	153.1 ms	83.3 ms	76.6 ms



CAUTION

- The impedance of the Sync Out connector is 50 Ω. Measurement may not be performed correctly if a coaxial cable with another impedance is used or if the impedance of the DUT is not 50 Ω.
- The output voltage of the Sync Out connector is -1.2 to 0 V. Check that the output voltage does not exceed the DUT maximum input specifications. If it does, connect an attenuator to the Sync Out connector.

Note:

PPG Pattern Sync cannot be set for the following Scope setting.

Time dialog box

Data Clock Rate: Tracking On

Procedure

1. Click **Sync Out**.
2. Select the type of signal output to Sync Output.

5.2.6 Setting Clk Out

Set a signal output from the **Clk Out** connector on the front panel. Clk Out is a function to output the clock synchronized to the data generated from the pulse pattern generator to the **Clk Out** connector on the front panel. The **Clk Out** connector is AC-coupled.

To measure the eye waveform using the sampling oscilloscope, connect the **Clk Out** connector and the **Trigger Clk In** connector of the sampling oscilloscope using a coaxial cable.

For MP2110A-x93, the clock output division rate is automatically changed according to the bit rate.

24.3 to 28.2 Gbit/s: 1/4Clock

9.5 to 14.2 Gbit/s: 1/2Clock

For MP2110A-x14, the clock source of clock output is selected from Ch1/2 or Ch3/4.

The jitter is reduced by matching the channel used for the measurement and the channel at Clk Out as shown in Figure 5.2.6-1. Refer to the descriptions at Jitter in Section A.2.2, “Pulse Pattern Generator”, for details of the jitter.

To perform the measurement using PPG/ED Ch1 and PPG/ED Ch2, set **Ch1/2**.

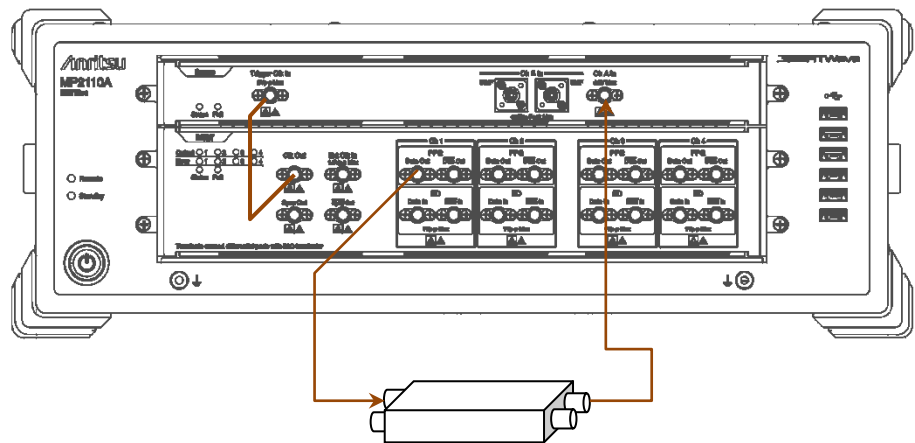

Figure 5.2.6-1 Connection Example When Setting Ch1/2 at Clk Out

To perform the measurement using PPG/ED Ch3 and PPG/ED Ch4, set **Ch3/4**.

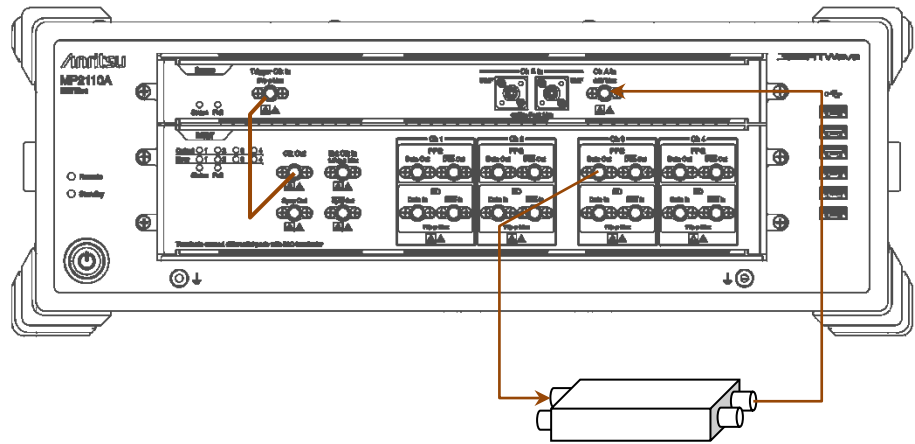

Figure 5.2.6-2 Connection Example When Setting Ch3/4 at Clk Out

5.2.7 Inserting Bit Error

Insert a bit error when confirming whether to detect the bit error at the ED. The number of bit errors to be inserted at one time is determined according to the bit rate.

24.3 to 28.2 Gbit/s : 20 bit

9.5 to 14.2 Gbit/s : 8 bit

Inserting bit errors one bit at a time using screen operation

Click **Insert Error**.

When inserting the bit error, the indicator on the right side of **Insert Error** lights red.

5.2.8 Setting Error Detection Method

Set the conditions for detecting a bit error.

Signal input connectors

The block diagram for **Data In** and $\overline{\text{Data In}}$ connectors on BERT panel is as shown below.

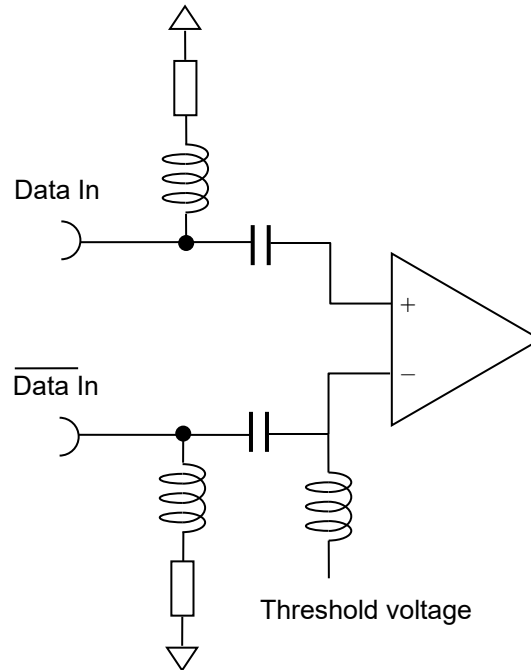

Figure 5.2.8-1 Input Connector Block Diagram

 **CAUTION**

- The impedance of the electrical input connector is 50 Ω. Measurement may not be performed correctly if a coaxial cable with another impedance is used.
 - Do not apply a DC voltage of more than 1 V to the Data In connector and the $\overline{\text{Data In}}$ connector. Otherwise, the internal circuits may be damaged.
-

Make a signal input connector selection, depending on the settings for **ED Input Condition**.

Differential 50 Ohm: Signal input connector for both **Data In** and **Data In** connectors. The differential voltage of each signal input to two connectors is the input voltage.

Electrical Single-Ended Data:

Signal input connector for **Data In** connector

Electrical Single-Ended XData:

Signal input connector for **Data In** connector

Attenuator Factor (External Attenuation)

When installing the fixed attenuator in the **Data In** and **Data In** connectors of the BERTWave, input the attenuation (dB) of the fixed attenuator.

The threshold voltage calculated to the input voltage of the attenuator is displayed.

The calculation formula is as follows:

Calculated Threshold Voltage = Threshold Voltage $\times 10^{(\text{attenuation}/20)}$



CAUTION

- When inserting the attenuators at both **Data In** connector and **Data In** connector, use the attenuators with the same amount of attenuation. When the attenuators with the different amounts of attenuations are used, the displayed threshold voltage and the actual threshold voltage are different.
- When the voltage input to the attenuator is more than 5 V or less than -5 V, check that the voltage consumed in the attenuator does not exceed the rated power of the attenuator.
- Check that the voltage of the signal attenuated in the attenuator does not exceed the voltages displayed at the **Data In** connector and **Data In** connector.

Threshold Level

Voltage level for evaluating “1” and “0”.

The input connectors are AC coupled, so set a voltage corresponding to the signal waveform excluding the DC components.

The waveform excepting the waveform input to the connector and the DC component when inputting the 1.2V LVCMOS signal to the **Data In** connector and **Data In** connector is shown below.

Set the threshold level to the waveform excepting the DC component.

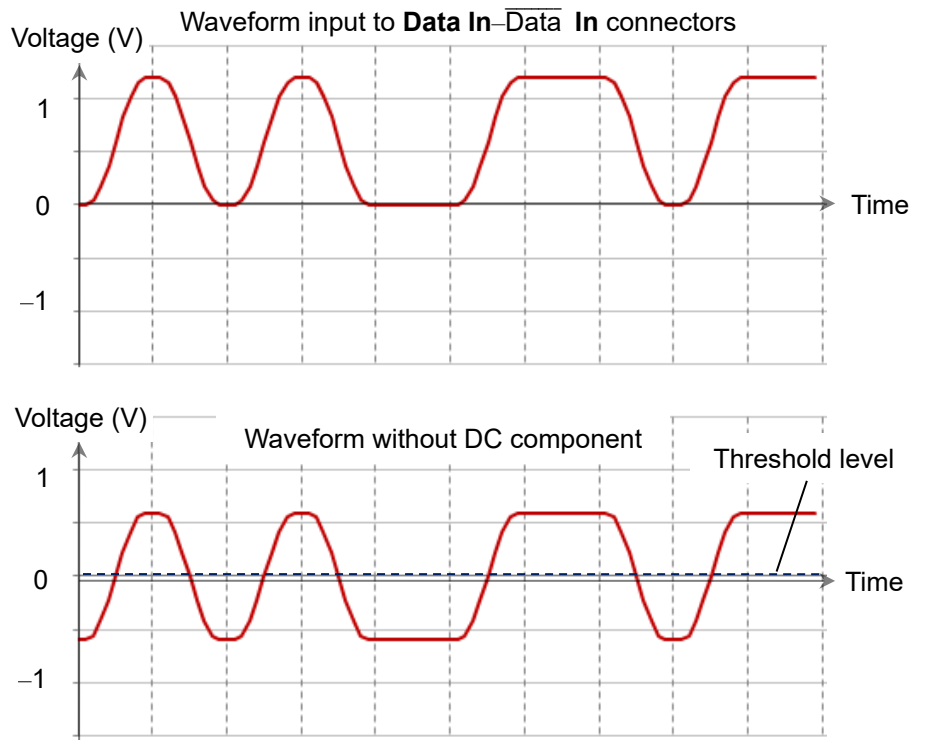

Figure 5.2.8-2 Waveform That Threshold Level Can be Set

Logic

Select the positive logic (POS) or negative logic (NEG).

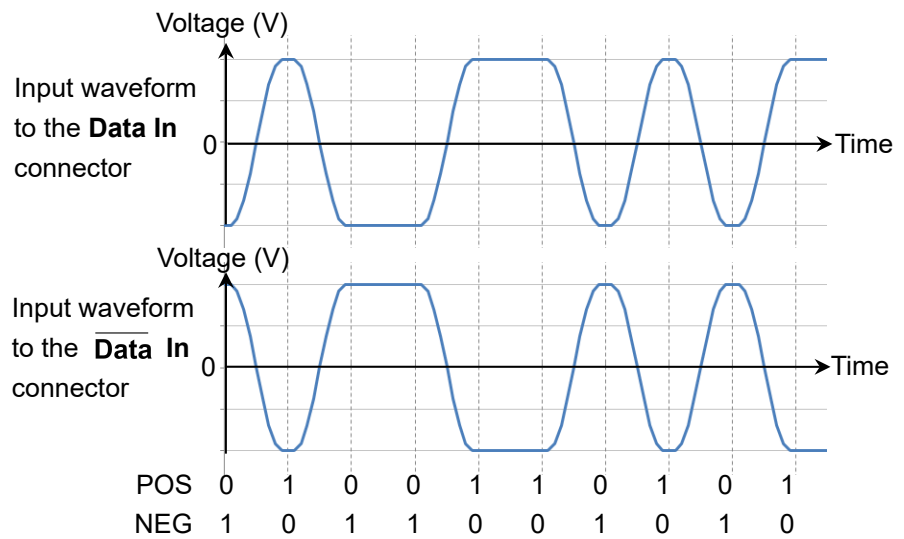

Figure 5.2.8-3 Values Defined as Input Waveform

Pattern

The ED compares the received bit string and the internally generated bit stream bit-by-bit and evaluates its differences as errors.

As a result, set the same pattern at the PPG and ED.

The setting procedure of the error detection conditions is as follows:

1. When changing the bit rate and pattern of the PPG and applying the changing settings to the ED click the Tracking button and set to **On**.
When setting to **On**, go to the step 6.
When setting to **Off**, go to the step 2.
2. Click the Bit Rate button and select the standard.
3. Click the Test Pattern button and select the pattern.
Set the same pattern of the PPG.
4. Set Logic to **POS** or **NEG**.
5. Click the ED Input Condition button.
6. Select the connector receiving the signal from the followings:

Differential 50 Ohm:	Data In and $\overline{\text{Data In}}$ connectors
Electrical Single-Ended Data:	Data In connector
Electrical Single-Ended XData:	$\overline{\text{Data In}}$ connector
7. Click the Ext ATT text box.
8. When inserting the fixed attenuator to the **$\overline{\text{Data In}}$** and **Data In** connectors, enter the attenuation (dB). When not inserting the attenuator, enter 0.
9. Click the Threshold text box.
10. Enter the threshold voltage.

5.2.9 Setting ED Measurement Condition

To set how to measure bit error:

Set Gating Cycle at Gating.

Single: Performs measurement until the time set at the measurement period is exceeded.

Repeat: Performs measurement until ER Result button display becomes **Stop**.

The bit error rate returns to 0 at each measurement period.

Untimed: Performs measurement until ER Result button display becomes **Stop**. The bit errors are accumulated.

The following figure shows the relationship between the Gating Cycle setting and the change in the displayed bit error count.

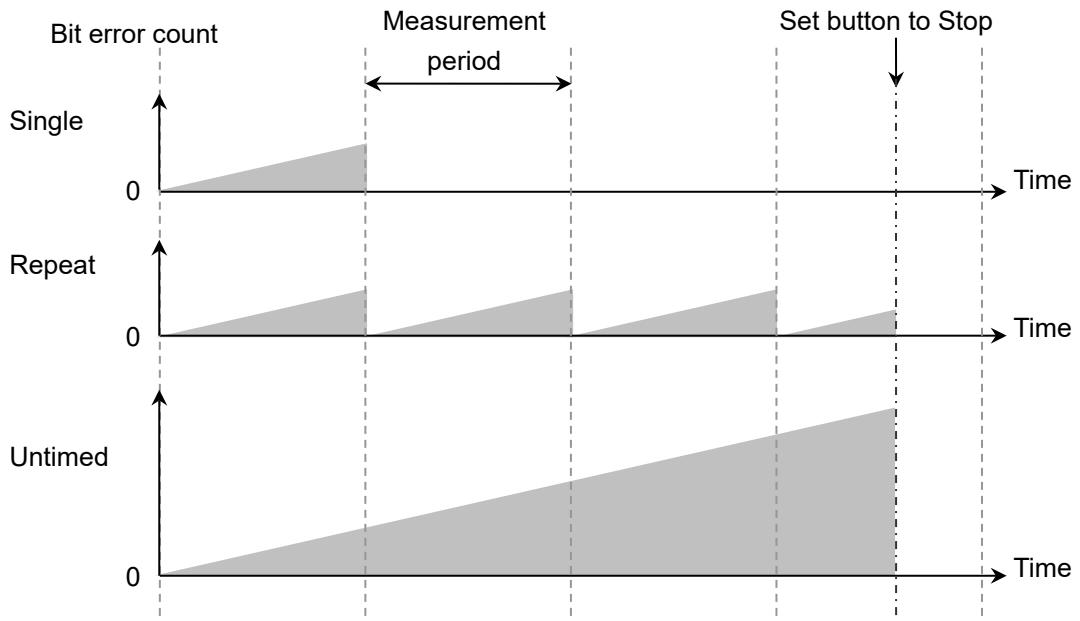

Figure 5.2.9-1 Gating Cycle Settings and Bit Error Count

Bit error measurement Period

The Gating Period can be set when Gating Cycle is Single or Repeat.

The time can be set from 1 second to 9 days 23 hours 59 minutes 59 seconds.

Measurement method

The ED Result display can be refreshed either in real time (approx. 0.1 s intervals) or when the progress bar reaches 100%. The display method is set at Current of Gating.

On: Updates measurement results in real time.

Off: Updates measurement results when progress reaches 100% for either Single or Repeat Gating Cycle.

Updates measurement results when measurement stops for Untimed Gating Cycle.

The setting procedure of the measurement conditions is as follows:

1. Click the Gating Cycle button and select the measurement method as follows:
 - Repeat**
 - Single**
 - Untimed**
2. When Gating Cycle is Repeat or Single, click the text box under the Gating Cycle and enter the numeric value.
The measurement cycle can be set from 1 second to 9 days 23 hours 59 minutes 59 seconds.
3. Click **Current** to set the timing for the measurement result.
 - On:** Updates measurement results per 100 ms.
 - Off:** Displays measurement results per measurement results or when measurement stops
4. Click **Start / Stop**.
The right indicator of the button is changed to green.
Measure is displayed at the status display.
The measurement processing rate is displayed.

When pattern synchronization is obtained, the SYNC Loss display is erased.

When Gating Cycle is set to **Untimed**, the measurement cycle progress is displayed every 5 seconds.

When SYNC Loss is displayed in red

Pattern synchronization has not been obtained; check the following:

- The Test Pattern generated by the DUT matches the Test Pattern for the error detector.
- The Logic POS and NEG settings are correct.
- A suitable threshold voltage has been set for the signal input to the **Data In** connector and the **Data In** connector.

Threshold is not between level 0 and 1

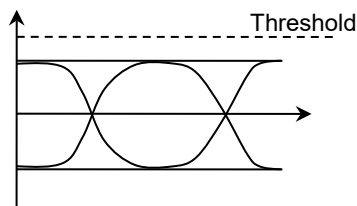

Excessive noise close to threshold level

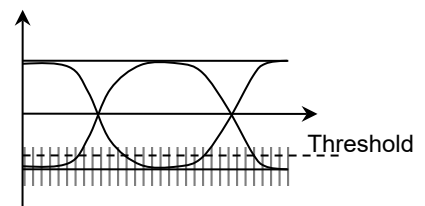

Figure 5.2.9-2 Examples of Improper Thresholds

5.2.10 Measurement Result

The following measurement result is displayed in the ED Result.

Start Time: Time when bit error measurement started

Elapsed Time: Time elapsed from start of bit error rate measurement
When Gating Cycle is Single or Repeat, when time exceeds the Time setting at Gating, the time is reset back to 0.

Remaining Time: Bit error measurement elapsed time subtracted from time set at Gating Time setting.

ER: The bit error rate is displayed from 0.0001E-18 to 1.0000E-03.

Mantissa is 0.0000 when the bit error does not occur.

At this time, the numeric part varies depending on the clock number.

Example: 0.0000E-03 Clock count 1000 or more, 9999 or less

0.0000E-04 Clock count 10000 or more, 99999 or less

EC: The occurred bit errors are displayed from 0 to 9999999 or from 1.0000E07 to 9.9999E17.

CC: The received bit count is displayed from 0 to 9999999 or from 1.0000E07 to 9.9999E17.

FREQ (kHz):

Clock frequency calculated by the received bit count.

It is the same as the transmission speed (kbit/s) of the received data.

Alarm Indicator

Error: Displays red when detecting bit error.

SYNC Loss: Displays red when pattern not synchronized.

When the alarm indicator goes red once, the History Indicator goes yellow when the cause of the alarm is removed, indicating that an alarm occurred.

When the **History Reset** button is pressed when the History Indicator is yellow, the yellow display disappears.

The threshold of SYNC loss (error rate where the pattern synchronization cannot be performed) varies depending on the bit rate, and the threshold is calculated using the following formula.

$$\text{Threshold value} = \frac{65565000}{\text{Bit rate (bit/s)}}$$

Example: When the bit rate is 28.2 Gbit/s, the threshold is 2.32E-3.

$$\frac{65565000}{28.2 \times 10^9} = 2.325 \times 10^{-3}$$

5.2.11 Saving Measurement Results

The measurement result of the saved bit error is as follows:

- Bit Error Measurement Result
- CC (Clock Count)
- EC (Error Count)
- ER (Error Rate)
- Frequency
- Start Time
- Stop Time
- Test Pattern

```
Anritsu;MP2110A ;01.00;TXT-----
Pattern PRBS2^9-1
Option 12,21,24,93
Start 2017/03/27 15:46:16      End 2017/03/27 15:46:26

      | Total
-----+-----
ER    | 0.0000E-11
EC    |          0

Frequency      Clock Count
-----+-----
25781250kHz   2.5781E+11
```

Figure 5.2.11-1 Text File Example

```
Anritsu;MP2110A;01.00;CSV
Pattern,PRBS 2^9-1
Option 12,21,24,93
Start 2017/03/27 15:46:16      End 2017/03/27 15:46:26

,Total
ER,0.0000E-11
EC,0

Frequency,Clock Count
25781250kHz,2.5781E+11
```

Figure 5.2.11-2 CSV File Example

Procedure

1. Click **System Menu**.
2. Click **Save**.
3. Select from **PPG/ED Ch1**, **PPG/ED Ch2**, **PPG/ED Ch3**, or **PPG/ED Ch4**.
4. Click **Result**.
The file name input dialog box is displayed.
5. When saving the file as the displayed file name, click **OK**.
6. Click the right button of the text box when editing the file name. The software keyboard is displayed.
7. Input the file name.
8. When changing the file name, click **OK**, and when canceling the procedure, click **Cancel** and go back to the step 4.

The measurement result file is saved in the following folder.

C:\Users\Public\Documents\Anritsu\MX210000A\UserData\Result\CSV

C:\Users\Public\Documents\Anritsu\MX210000A\UserData\Result\TXT

5.3 Setting Restrictions

The setting items of the PPG have the following restrictions.

When Test Pattern is not PRBS (Test Pattern is 1/2 Clock or 1/16 Clock) in MP2110A, the Pattern Sync is disabled due to the hardware restrictions. The setting item can be selected, but “PPG 1/8 Clock” is output under this condition.

When the following conditions are met, no signal is output from Clk Out.

- The bit rate operates in the range from 24.3 to 28.2 Gbit/s.
- “1/2 Clock Pattern” is set at PPG Test Pattern in one of the channels specified at the Clk Out Source Channel setting (Ch1/2 or Ch3/4).

Chapter 6 *How to Operate Sampling Oscilloscope*

This chapter explains the Sampling Oscilloscope setting items and how to measure the waveform.

Note:

This chapter explains how to operate MP2110A with the software version 7.04.19 or later.

6.1	Measurement Procedure.....	6-2
6.2	Explanation of Windows.....	6-3
6.2.1	Result Window.....	6-3
6.2.2	Displaying Measured Jitter.....	6-14
6.2.3	Setup Dialog Box.....	6-26
6.2.4	Measure Dialog Box.....	6-32
6.2.5	Amplitude O/E Dialog Box.....	6-49
6.2.6	Time CRU Dialog Box.....	6-55
6.3	Calibration and Adjustment.....	6-62
6.3.1	Calibrating Level.....	6-62
6.3.2	Adjusting Dark Current.....	6-64
6.3.3	Adjusting Values for Changing the Wavelength Bands.....	6-64
6.3.4	Performing Self Test.....	6-66
6.4	Setting CRU.....	6-67
6.5	Setting Rate.....	6-71
6.5.1	Setting Symbol Rate.....	6-72
6.5.2	Setting Clock Rate and Divide Ratio.....	6-73
6.6	Setting Pattern Length.....	6-74
6.6.1	NRZ.....	6-74
6.6.2	PAM4.....	6-75
6.7	Collecting Data.....	6-76
6.8	Adjusting Scales.....	6-82
6.8.1	Adjusting Scales Automatically.....	6-82
6.8.2	Adjusting Vertical Axis.....	6-85
6.8.3	Adjusting Horizontal Axis.....	6-87
6.9	Measuring Waveform.....	6-88
6.9.1	Setting and Displaying Measurement Items... ..	6-90
6.9.2	Mask Test.....	6-103
6.9.3	Jitter Analysis.....	6-112
6.9.4	Measurement Using Histogram.....	6-119
6.9.5	Using Marker.....	6-122
6.9.6	Displaying Waveform Calculation.....	6-124
6.9.7	Using Trace Memory.....	6-125
6.9.8	Displaying a Label.....	6-126
6.9.9	Saving Measurement Results.....	6-127



6.1 Measurement Procedure

The following figure shows the basic measurement procedure.

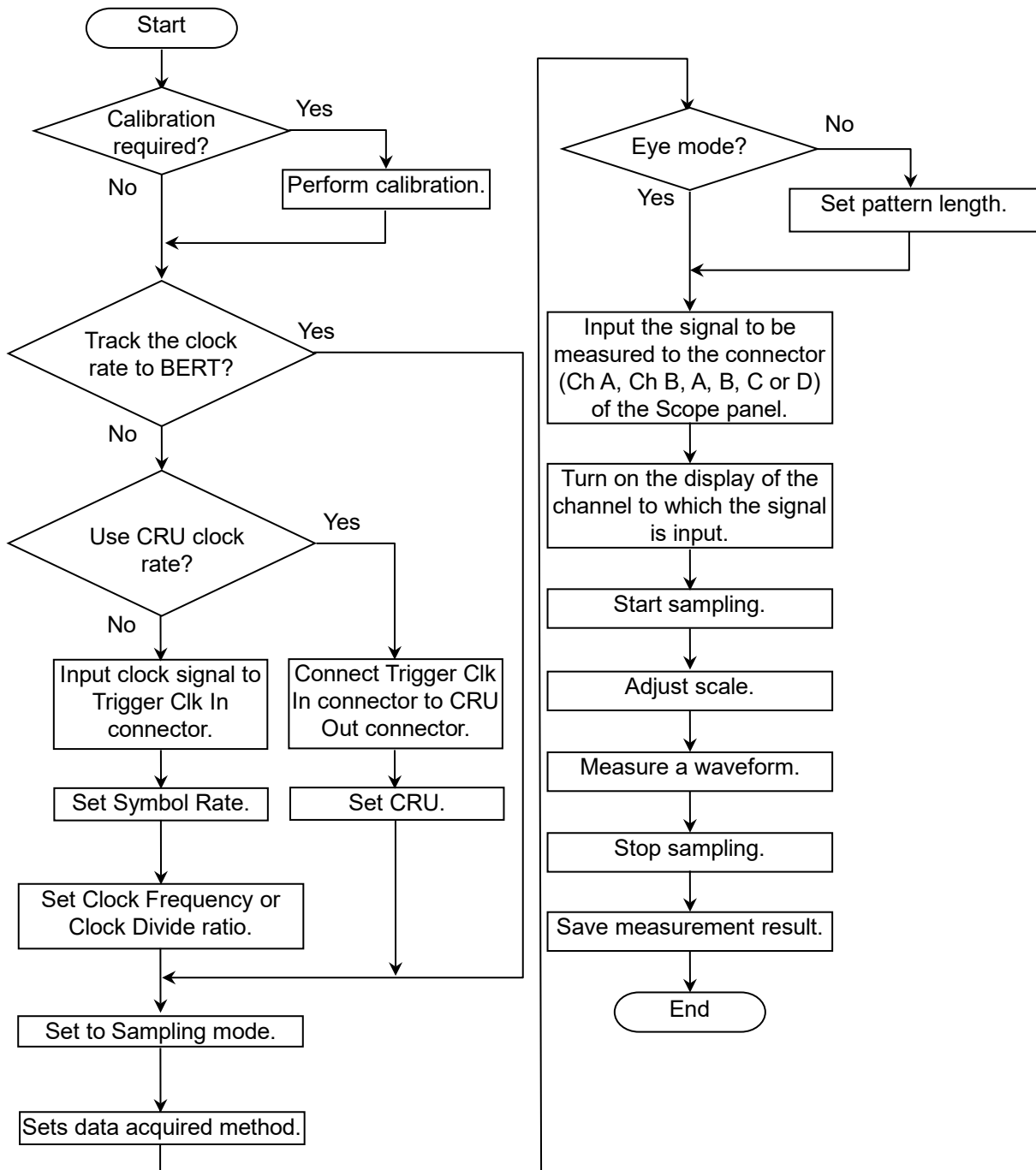

Figure 6.1-1 Basic Measurement Procedures

6.2 Explanation of Windows

6.2.1 Result Window

In the function menu, click **Scope**, and then the Scope result window is displayed.

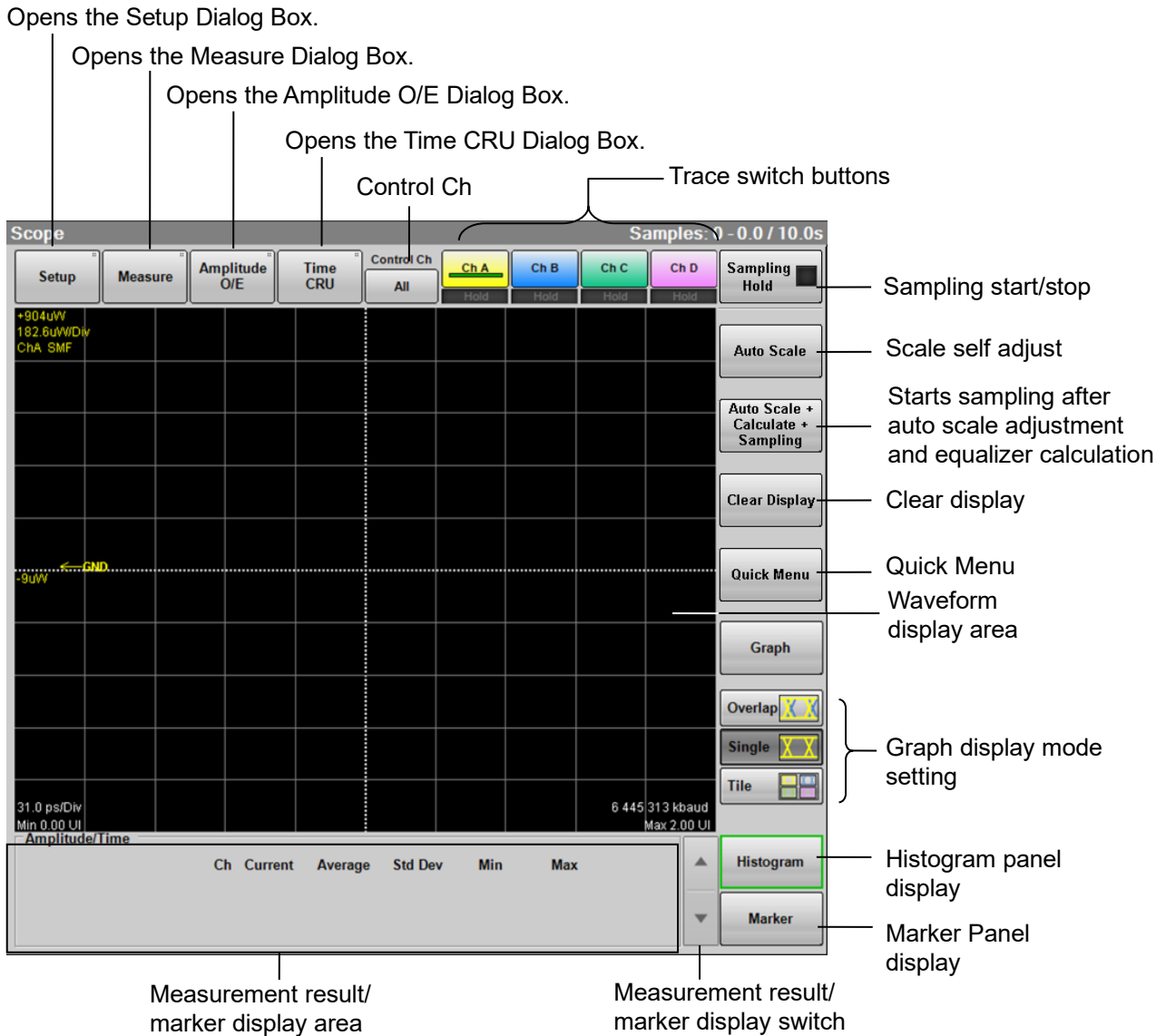

Figure 6.2.1-1 Result Window

When no scope option is installed but MP2110A-x55 26G/53Gbaud Clock Recovery (SM Optical) is installed, the Result window is not displayed. The Time dialog box is displayed, instead.

When you click **Setup**, **Measure**, **Amplitude O/E** or **Time CRU**, the corresponding dialog box is displayed.

MP2110A-x21 Dual Electrical Scope does not display **Amplitude O/E** but **Amplitude**.

When MP2110A-x54 Clock Recovery (Electrical/Optical) and MP2110A-x55 26G/53Gbaud Clock Recovery (SM Optical) are not installed, not **Time/CRU** but **Time** is displayed.

When Channel Math in Figure 6.2.5-1 Amplitude Dialog Box (When MP2110A-x21) is **On**, **Scale/Offset** cannot be operated.

Trace switch buttons

Set the trace(s) to display on the graph and the channel to control (hereinafter, active channel).

When the color of the trace button is gray, the trace is not displayed on the graph.

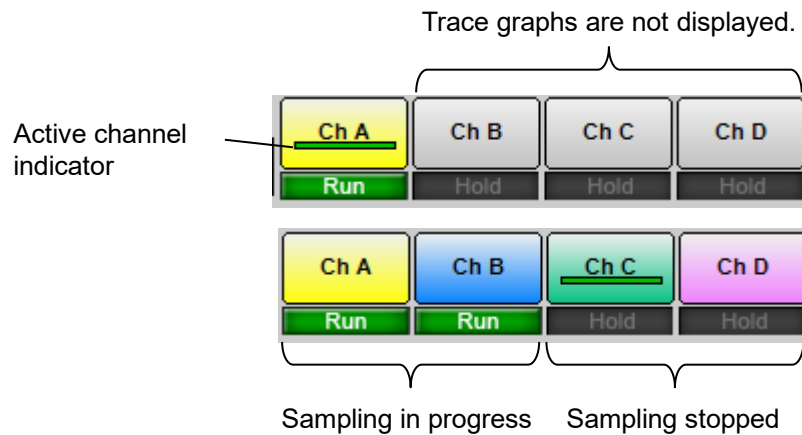

Figure 6.2.1-2 Trace Switch Buttons

Control Ch

Toggles the channel(s) to be controlled by **Sampling**, **Auto Scale**, **Auto Scale + Calculate + Sampling**, and **Clear Display**.

All All channels

Single Active channel only

When **Control Ch** is set to **Single**, the buttons effective only for the active channel are indicated by the same color as the active channel.

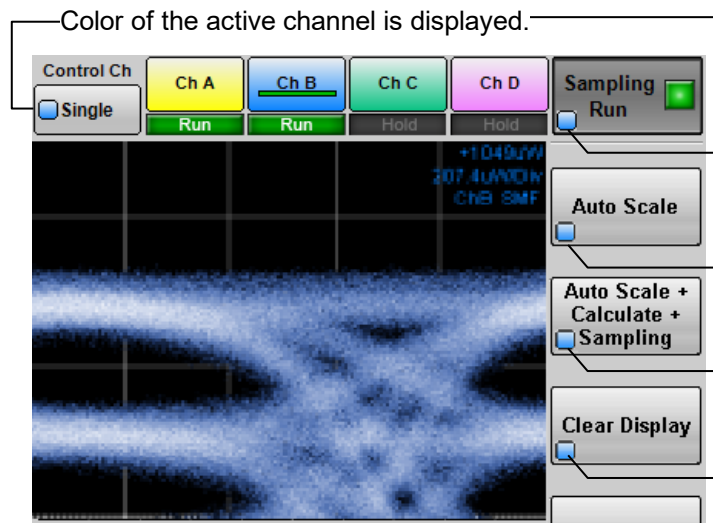

Figure 6.2.1-3 When Control Ch is Set to Single

When **Control Ch** is set to **Single**, the buttons in the following dialog boxes and effective only for the active channel are also indicated by the same color as the active channel.

- Setup Dialog Box
- Measure Dialog Box
- Amplitude O/E Dialog Box
- Time CRU Dialog Box

Items set only for the active channel are indicated by the color of the active channel.

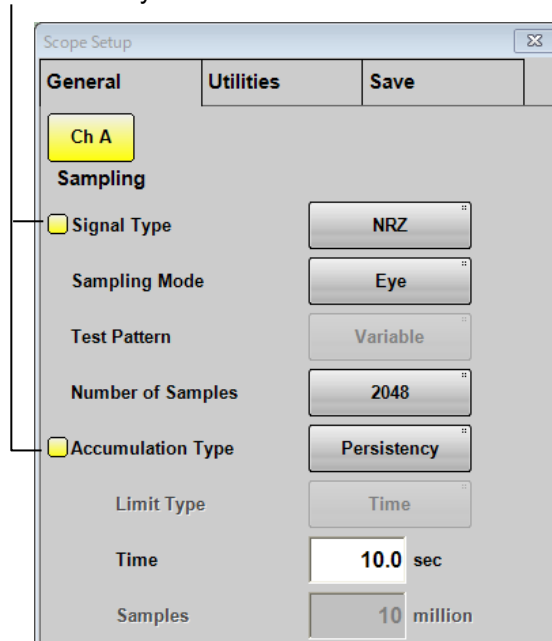

Figure 6.2.1-4 How Setting Items Look When Control Ch is Set to Single

Even if Control Ch is set to **All**, the items indicated by the active channel color can be set separately.

Note:

If the following items do not match among channels, “* The setting of each channel is different” is displayed.

- Accumulation Type on the **General** tab
- Input Connector (Wavelength) on the **O/E** tab
- Filter on the **O/E** tab

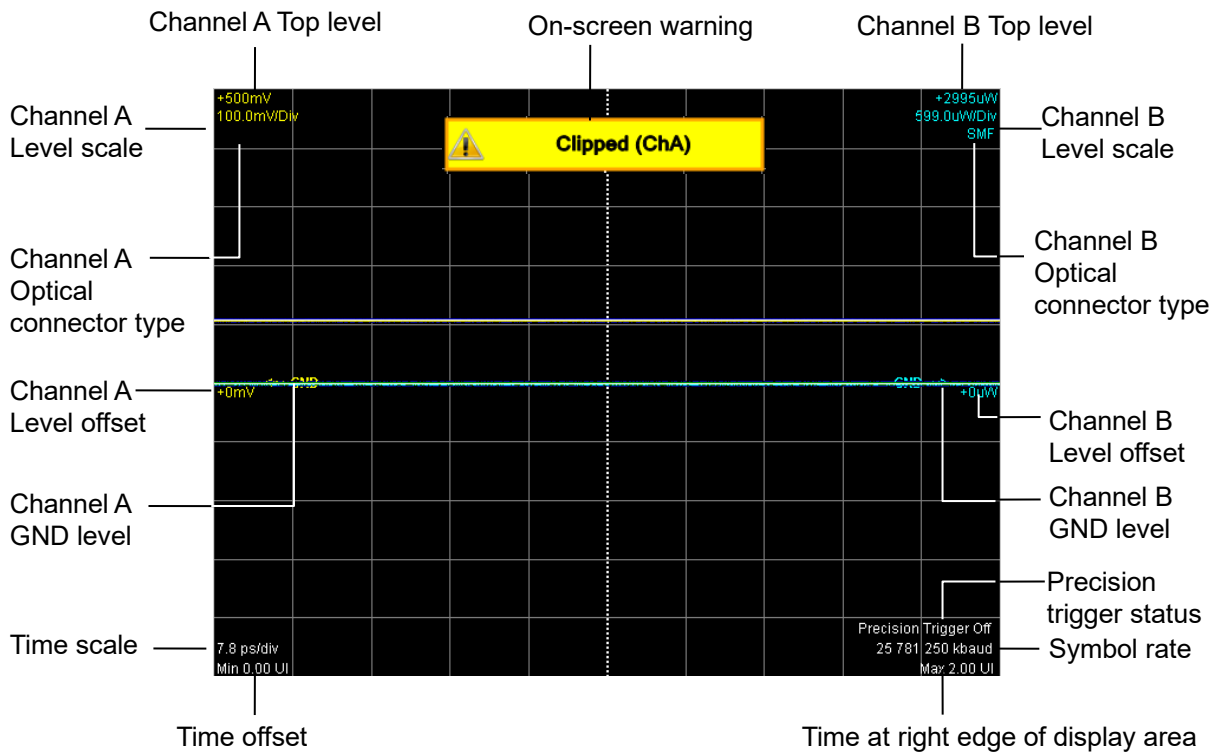

Figure 6.2.1-5 Waveform Display Area

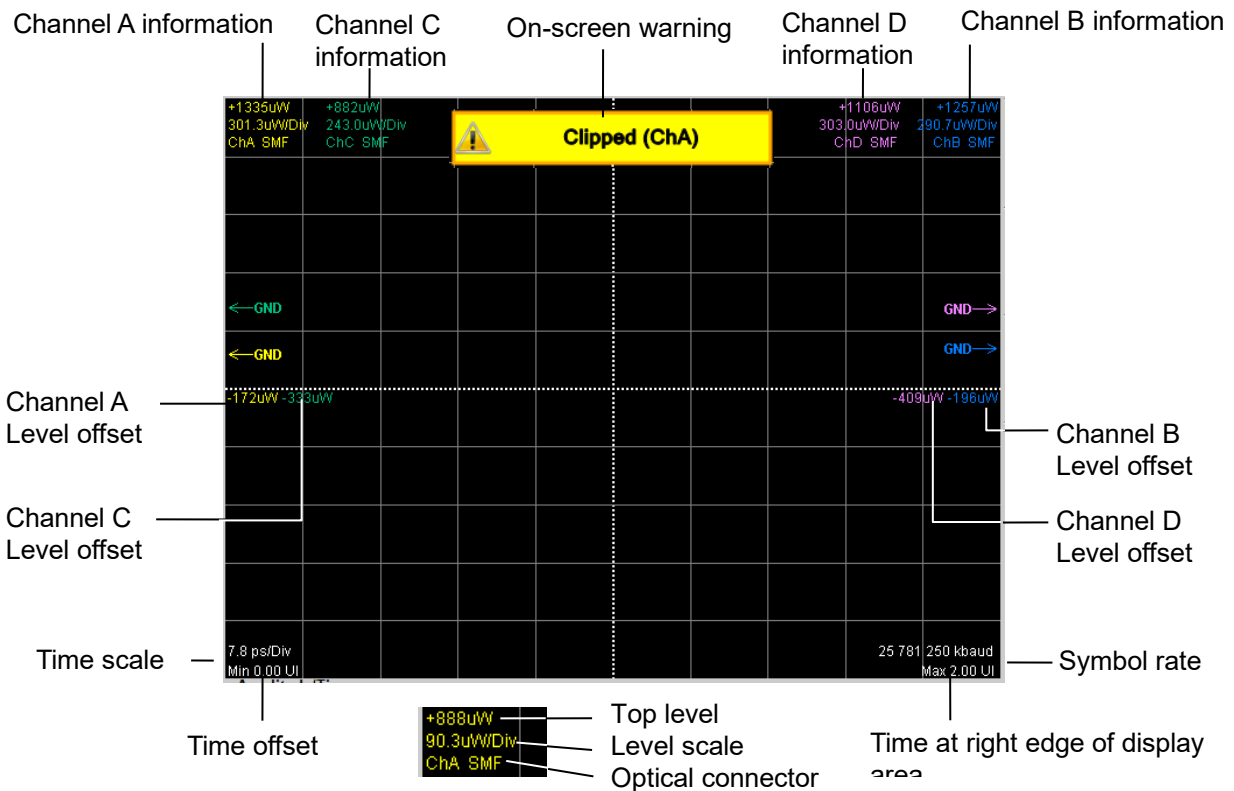

Figure 6.2.1-6 Waveform Display Area
(MP2110A-x30, MP2110A-x39, MP2110A-x40, and MP2110A-x49)

Note:

The arrows that indicate the GND levels appear differently according to the options installed.

- With MP2110A-x21, x22, x23, x25, x26, x40, x42, x43, x45, x46 or x49, the GND levels are indicated by thick lines.

Ch A:  Ch B:  Ch C:  Ch D: 

- With MP2110A-x30, x32, x33, x35, x36 or x39, the GND levels are indicated by thin lines.

Ch A:  Ch B:  Ch C:  Ch D: 

Depending on the type of input signal, you may receive a warning in the waveform display area. In this case, connect an attenuator to the optical connector to lower the input level.

Overload: The waveform is distorted because the optical input power exceeds the upper limit.

An index of the peak power level is 2200 μ W for SM (2600 μ W for MP2110A-x30 and x40) and 3200 μ W for MM.

Clipped: A clipped waveform is displayed because the amplitude of the electrical input signal (for optical input, O/E-converted signal) exceeds the dynamic range. An index of the dynamic range is ± 400 mV.

Quick Menu

Provides the setting items frequently used.

For how to adjust scale and offset, refer to 6.8, "Adjusting Scales",

Amplitude:

Sets the scale and offset of the vertical axis.

Time:

Sets the scale and offset of the horizontal axis.

When Sampling Mode is **Pulse**, **Offset** is displayed.

Otherwise, **Delay** is displayed.

Waveform:

Sets the button color of the active channel.

When, in the **Setup** Dialog Box, Waveform is set to **Gray Scale**, the color of the trace graph changes as well.

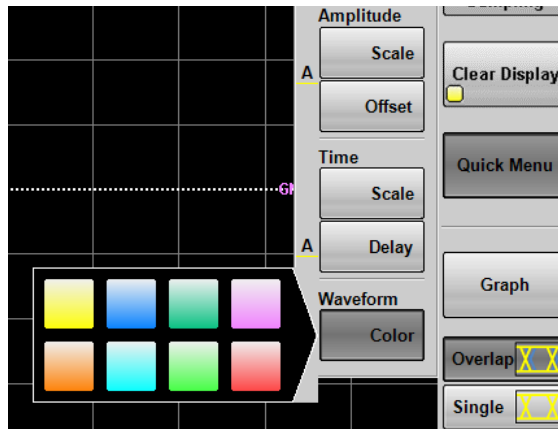

Figure 6.2.1-7 Quick Menu

Graph display mode setting

There are three graph display modes.

Overlap: Overlaps traces of multiple channels.

Single: Displays only the trace of the active channel.

Tile: Displays four trace graphs in tile view.

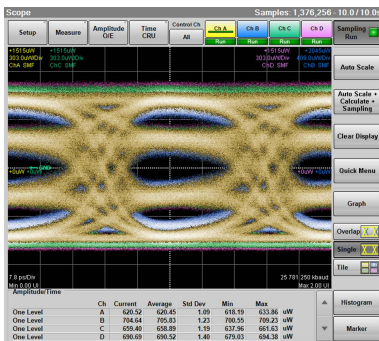

Overlap

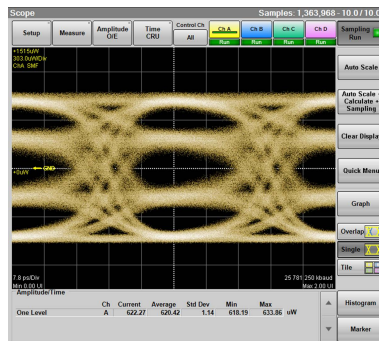

Single

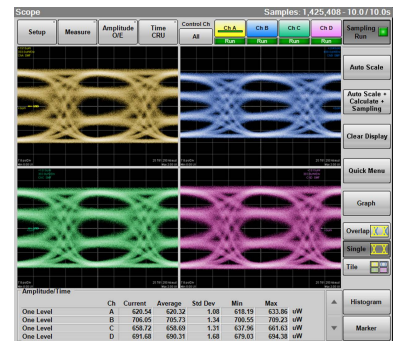

Tile

Figure 6.2.1-8 Graph Display Modes

The graph size changes depending on the number of measurement results displayed on Result Window.

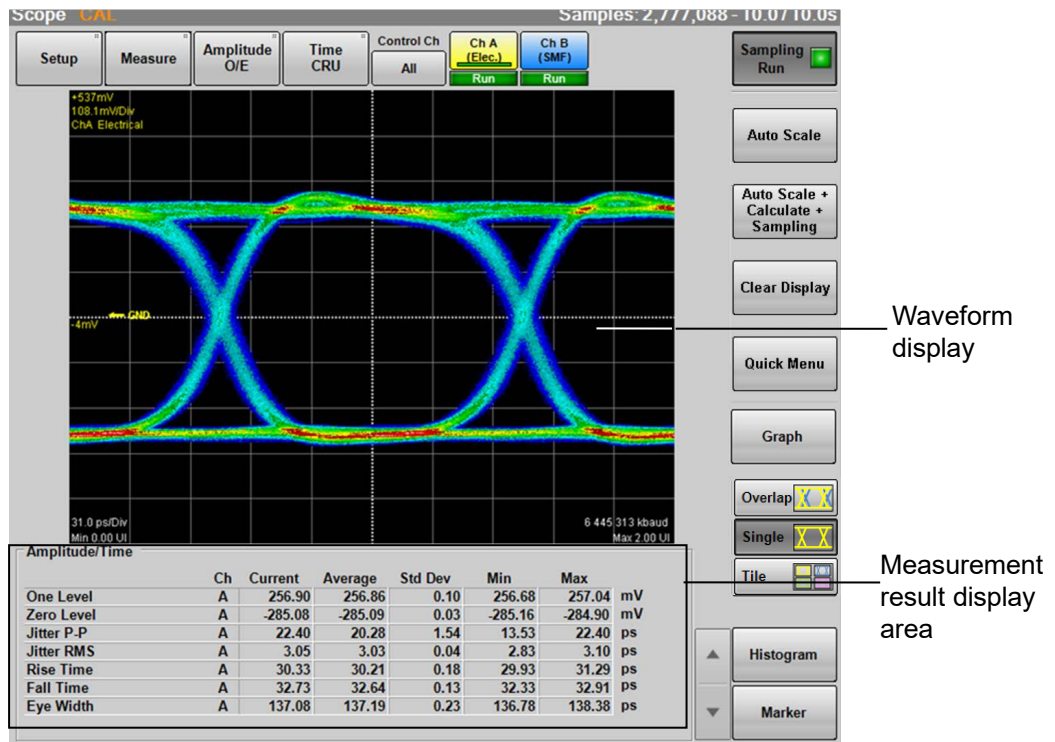

Figure 6.2.1-9 Result Window (Number of measurement items is from five to eight)

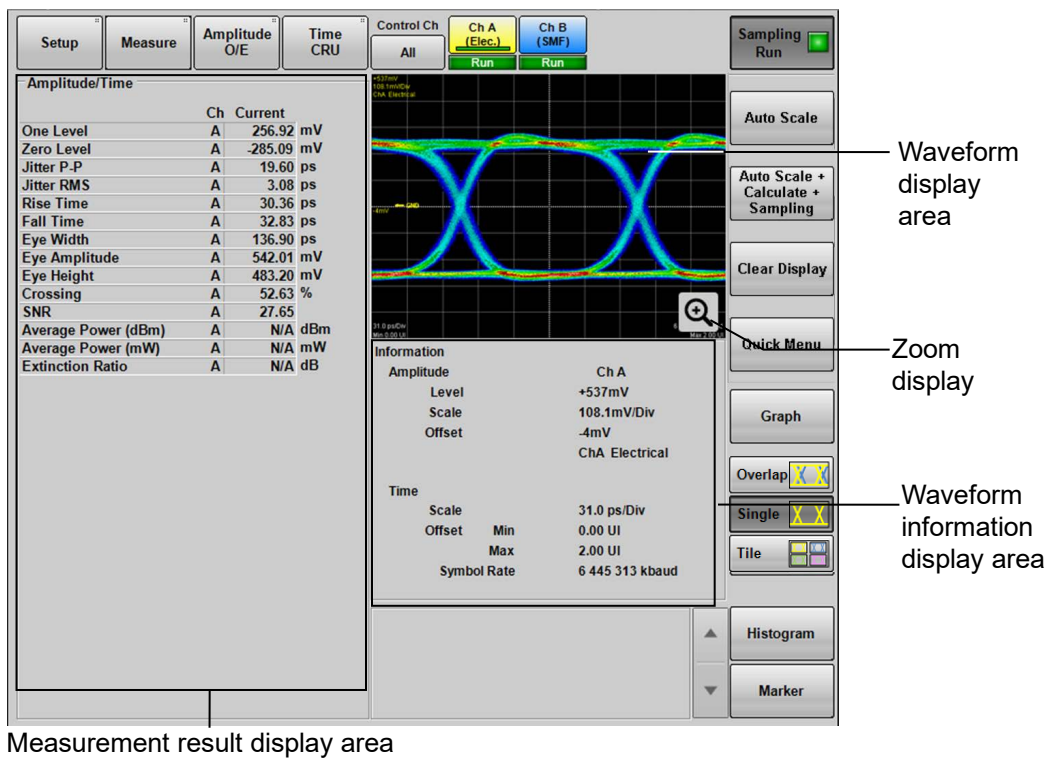
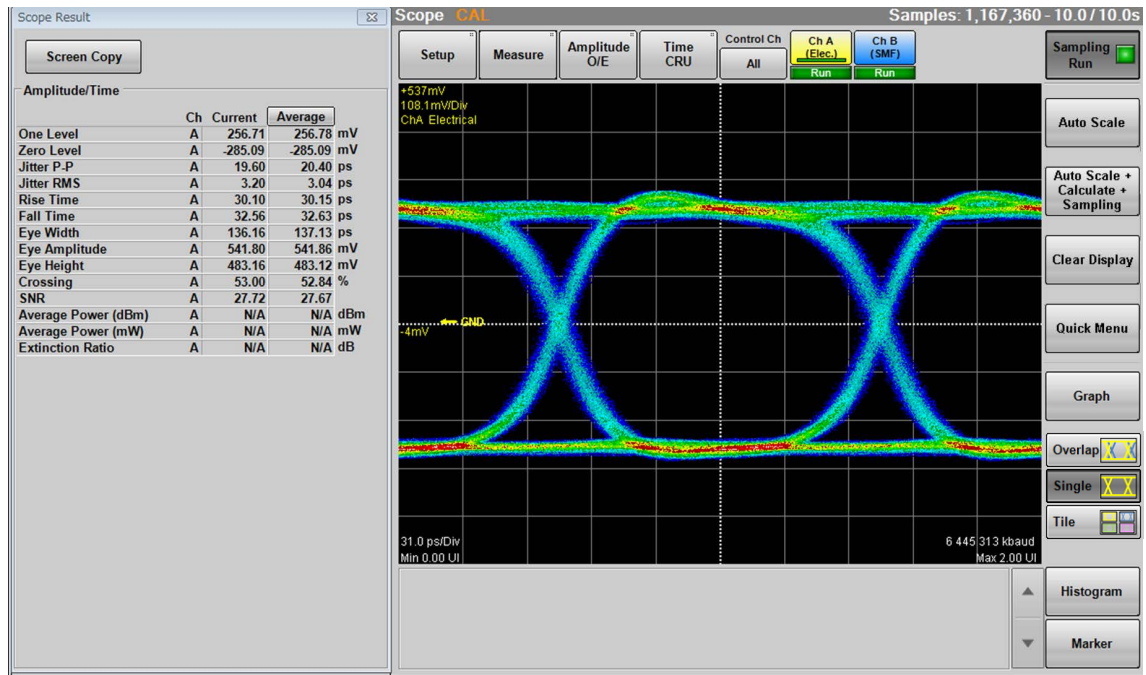

Figure 6.2.1-10 Result Window (Number of measurement items is nine or more)

When the number of measurement items is nine or more, Zoom display icon (🔍) is shown. Clicking this icon displays **Scope Result** dialog box and the waveform is displayed larger.



**Figure 6.2.1-11 Enlarging Display of Result Window
(Number of measurement items is nine or more)**

Click **Screen Copy** in the **Scope Result** dialog box to save the images of the Result window and **Scope Result** dialog box to a file.

For the method of saving files and the destination folder, refer to 4.3.3 “Screen Copy”.

Measurement result display area

Current column displays the values calculated from all the samples measured and accumulated since the start of measurement. Therefore, use the Current value as the result of measurement in Limited mode. On the other hand, the Average, Std Dev, Min, and Max columns display statistical values relative to the Current values updated at each waveform acquisition from the start of measurement. These values can be used when the Accumulation Type is set to the one of the following.

- **None**
- **Persistency**, and when amount of accumulated waveform data samples is not enough (as a guide, when Time is 1.0 or less).

Items that were not measured accurately are displayed with N/A instead of results. Some items are displayed with reasons why they cannot be measured.

Table 6.2.1-1 Items Displayed with Reasons

Reason	Description	Measurement Item
OMA?	Cannot measure accurately since there is a large noise influence inside the Scope due to too small Outer OMA or VMA.	TDECQ, Partial TDECQ, Noise Margin, Partial Noise Margin
SER?	Cannot drive the waveform SER into the target SER.	TDECQ, Partial TDECQ, Noise Margin, Partial Noise Margin

When clicking a measurement item, the letter turns blue, and the measurement area is displayed with a yellow dotted line in the window. When clicking the measurement item again, the display of the measurement area disappears.

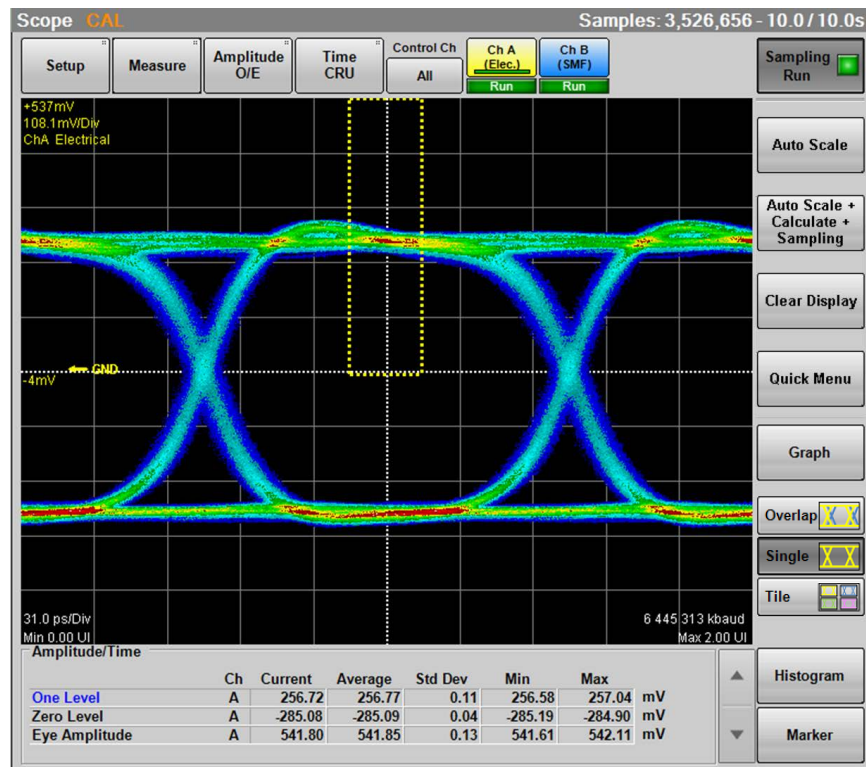

Figure 6.2.1-12 Display Example of Measurement Area

Status Display

The following statuses of the sampling oscilloscope are displayed.

Table 6.2.1-2 Status Display Items

Item	Color	Description
CAL	Orange	The correction value of O/E is not appropriate. Calibrate the O/E module according to 6.3.2, "Adjusting Dark Current".
CAL	Yellow	There is a difference of ± 2.5 °C or more from the calibration temperature. Calibrate the level according to 6.3.1, "Calibrating Level".
CAL	Red	The sampling oscilloscope meets one of the following: <ul style="list-style-type: none"> • There is a difference of ± 5.0 °C or more from the calibration temperature. • CAL is required according to software version upgrade. Calibrate the level according to 6.3.1, "Calibrating Level".
26G CRU Unlock	Orange	MP2110A-x54 Clock Recovery (Electrical/Optical) is not locked on the input signal.
53G CRU Unlock	Orange	MP2110A-x55 26G/53Gbaud Clock Recovery (SM Optical) is not locked on the input signal.

Table 6.2.1-2 Status Display Items (Cont'd)

Item	Color	Description
Free Running	Red	The trigger clock cannot be detected.
PT phase unlock*	Orange	Precision Trigger is not locked on the input signal.
Trigger setting wrong	Orange	The trigger clock can be detected, but its frequency does not match the clock frequency setting value.

*: Displayed when the MP2110A-x24 is installed.

6.2.2 Displaying Measured Jitter

When MP2110A-x96 is installed, **Graph** is displayed in the Result window.

Click **Graph** to display the Graph selection buttons.

Note:

Graph cannot be operated when Sampling Mode is set to **Pulse** or **Coherent Eye**.

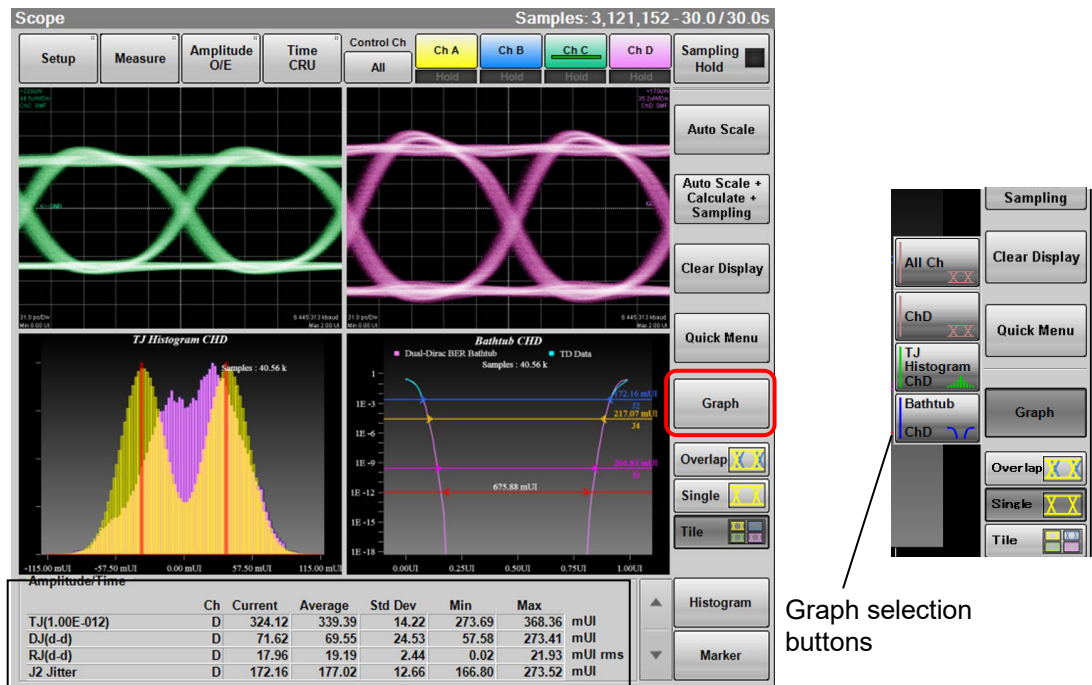

Jitter analysis result

Figure 6.2.2-1 Result Window (Graph Display)

When **Advanced Jitter** is set to Sampling Mode in the Setup dialog box, the following buttons in the Result window cannot be operated.

Control Ch, Auto Scale, Auto Scale + Calculate + Sampling, Clear Display, Quick Menu, Overlap, Histogram, Marker

When the Correction Factor of Figure 6.2.4-8 “Jitter Measure Dialog Box - Advanced Tab” is ON, corrected value(s) is(are) indicated by “*1”, in red letters, in the measurement result display area. When Fixed RJ is ON, “*2” is displayed at RJ.

		*1:Corrected *2:Fixed							
	Ch	Current	Average	Std Dev	Min	Max			
TJ(1.00E-012)	*1	B	153.31	154.55	16.10	135.02	303.41	mUI	
RJ(d-d)	*2	B	6.45	6.45	0.00	6.45	6.45	mUI rms	
DJ(d-d)	*1	B	62.63	63.88	16.09	44.41	212.73	mUI	
EYE Opening	*1	B	846.69	845.45	16.10	696.59	864.98	mUI	

Figure 6.2.2-2 Example of How Corrected Measurement Results are Displayed

Displaying Graphs

When **Graph** in the Result window is clicked, Graph selection buttons appear and the graph to display can be selected.

When Sampling Mode is **Eye**, the active channel is displayed on the button.

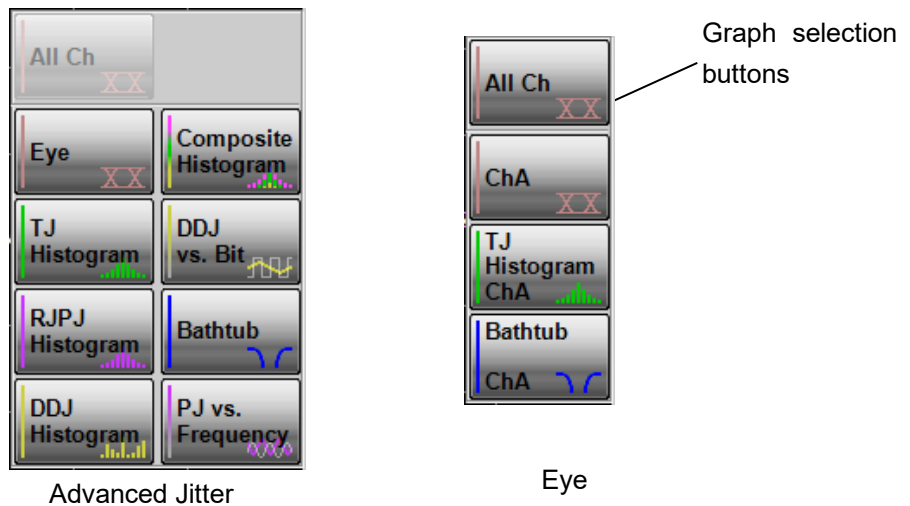

Figure 6.2.2-3 Examples of Graph Selection Buttons

The graph can be switched between enlarged display and reduced (four screens) display.

To switch the display size of the graph, click **Single** or **Tile**.

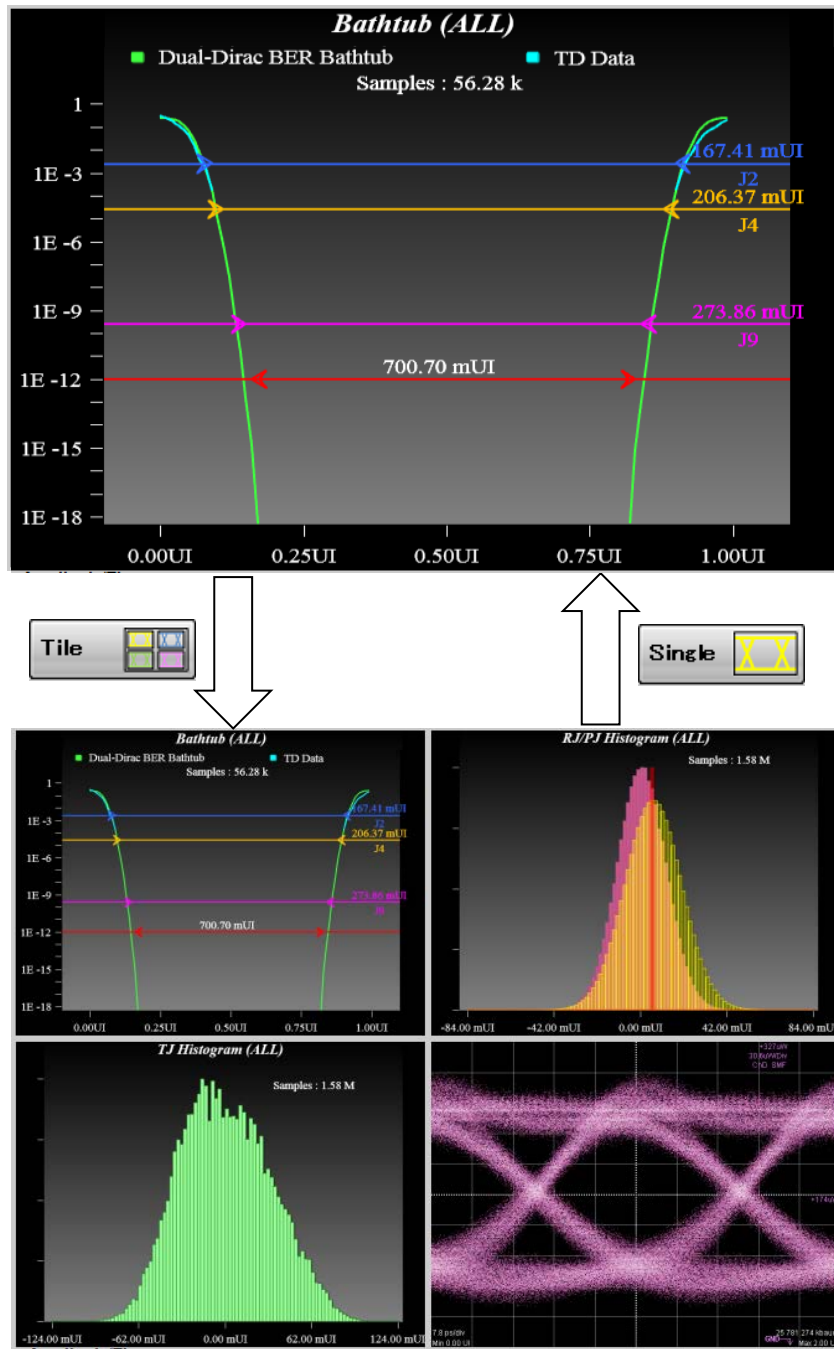

Figure 6.2.2-4 Switching Graph Display

6.2.2.1 Display of Eye Measurement

TJ Histogram

When clicking **TJ Histogram**, a graph selection button, the histogram of the active channel is displayed.

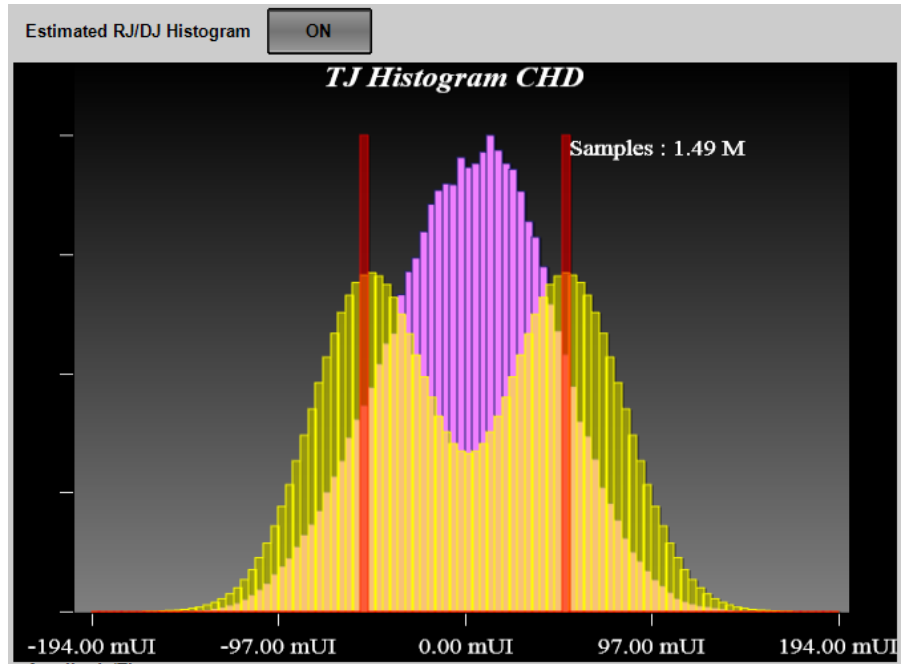

Figure 6.2.2.1-1 TJ Histogram

Table 6.2.2.1-1 TJ Histogram Item

Name	Description
Estimate RJ/DJ Histogram	Appears when Sampling Mode is set to Eye . Switches the histogram display for RJ and DJ estimated with dual dirac function. DJ amplitude is displayed with red lines.
Samples	The number of samples for the histogram

Bathtub

When clicking **Bathtub** on the Graph selection buttons, a bathtub curve for the active channel is displayed.

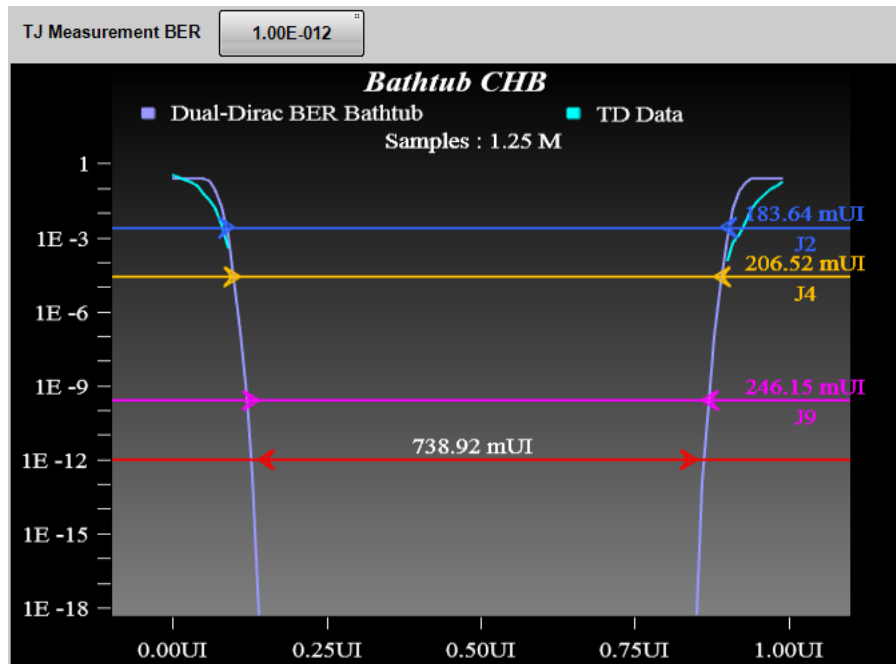

Figure 6.2.2.1-2 Bathtub

Table 6.2.2.1-2 Bathtub Item

Name	Description
TJ Measurement BER	Sets the BER to measure the TJ and eye opening. The red line and eye opening are displayed at the location of specified BER. The eye opening is displayed at the measurement result area.
TD data	BER curve line measured with Scope
Dual-Dirac BER Bathtub	BER curve line approximated with the dual dirac function from TD data
J2	The location of 2.5×10^{-3} BER and TJ are displayed.
J4	The location of 2.5×10^{-5} BER and TJ are displayed.
J9	The location of 2.5×10^{-10} BER and TJ are displayed.
Samples	The number of samples for the histogram

6.2.2.2 Graphs of Jitter Analysis (Advanced Jitter)

For jitter analysis (Advanced Jitter), except for the DDJ Histogram graph, the type of measurement edge (All, Fall or Rise) is displayed in the graph name. The measurement edge type is set on the **Algorithm** tab of the **Jitter Measure** dialog box.

TJ Histogram

Click **TJ Histogram** on the Graph selection buttons to display TJ's histogram.

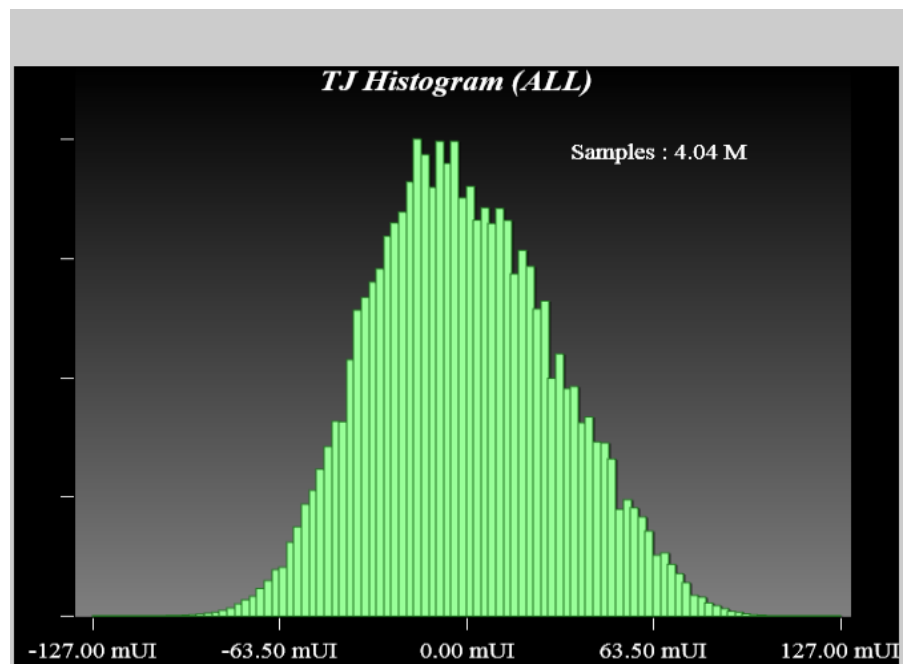

Figure 6.2.2.2-1 TJ Histogram

Table 6.2.2.2-1 TJ Histogram Item

Name	Description
Samples	The number of samples for the histogram

Bathtub

When clicking **Bathtub** on the Graph selection buttons, the following graph is displayed.

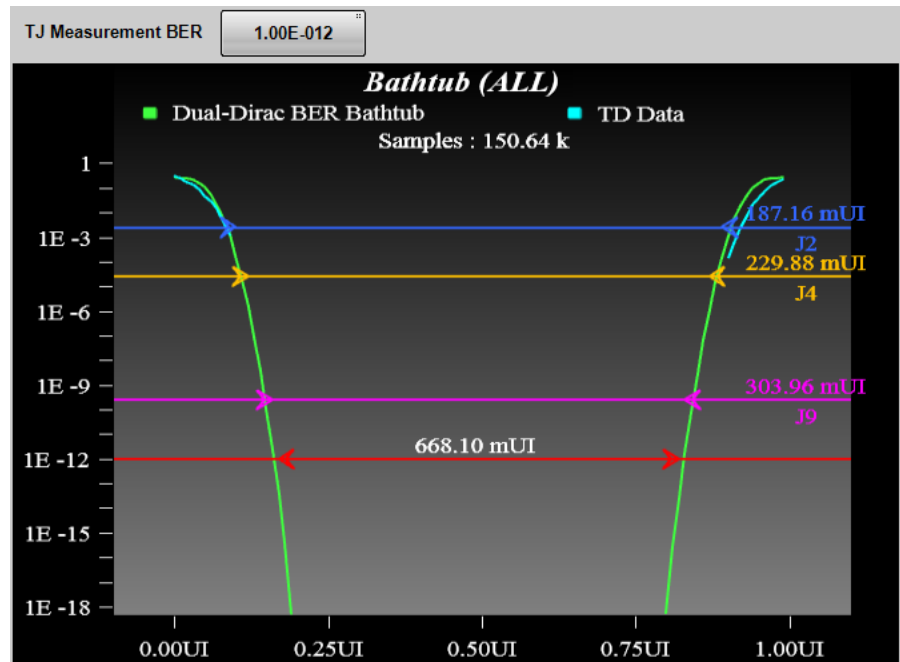

Figure 6.2.2.2-2 Bathtub

Table 6.2.2.2-2 Bathtub Item

Name	Description
TJ Measurement BER	Sets the BER to measure the TJ and eye opening. The red line and eye opening are displayed at the location of specified BER. The eye opening is displayed at the measurement result area.
TD data	BER curve line measured with Scope
Dual-Dirac BER Bathtub	BER curve line approximated with the dual dirac function from TD data
J2	The location of 2.5×10^{-3} BER and TJ are displayed.
J4	The location of 2.5×10^{-5} BER and TJ are displayed.
J9	The location of 2.5×10^{-10} BER and TJ are displayed.
Samples	The number of samples for the histogram

RJ/PJ Histogram

Clicking **RJPJ Histogram** on the Graph selection buttons, a histogram that is the sum of RJ and PJ is displayed.

When Estimate RJ / PJ Histogram is set to **ON**, histogram of RJ approximated by dual Dirac function is displayed in yellow and amplitude of PJ is displayed in red line.

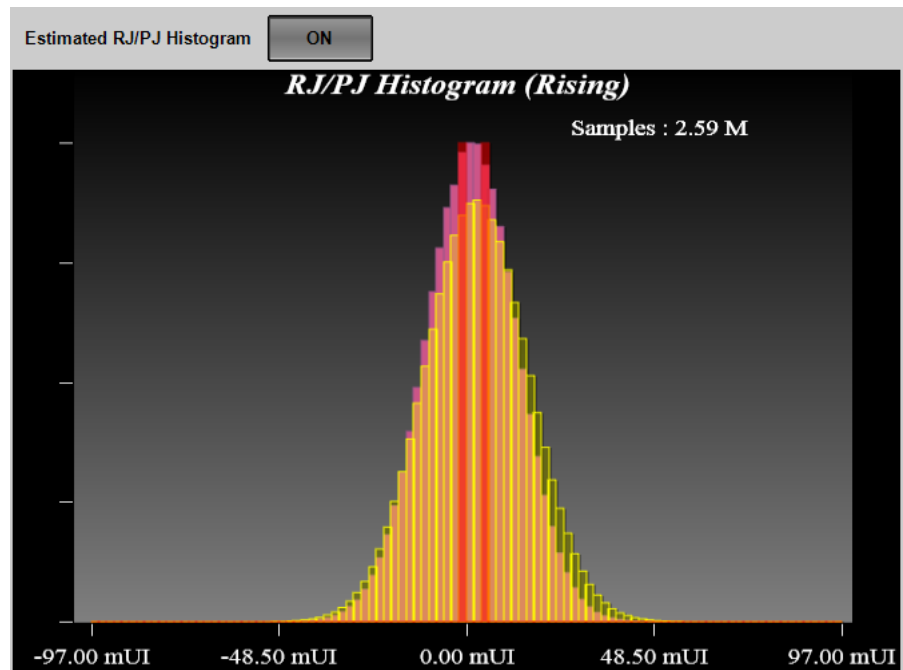

Figure 6.2.2.2-3 RJ/PJ Histogram

Table 6.2.2.2-3 RJ/PJ Histogram Item

Name	Description
Estimate RJ/PJ Histogram	Switches the histogram display for RJ and PJ estimated with dual dirac function. PJ amplitude is displayed with red lines.
Samples	The number of samples for the histogram

Composite Histogram

Click **Composite Histogram** on the Graph selection buttons, TJ, RJ/PJ, and DDJ histograms are displayed.

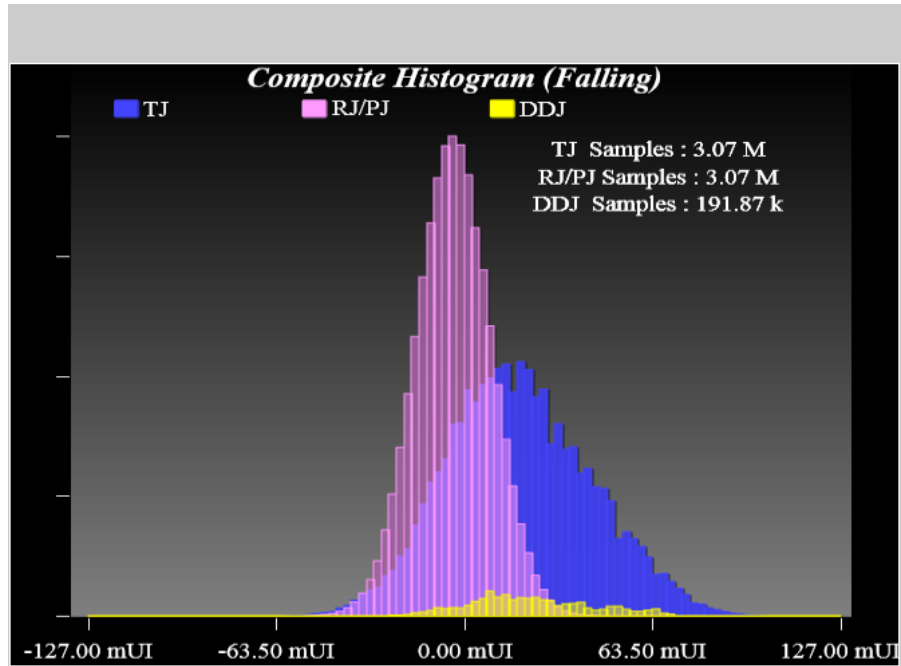

Figure 6.2.2.2-4 Composite Histogram

Table 6.2.2.2-4 Composite Histogram Item

Name	Description
TJ Samples	The number of samples for the histogram
RJ/PJ Samples	
DDJ Samples	

DDJ Histogram

Click **DDJ Histogram** on the Graph selection buttons, the histogram of DDJ is displayed by edge.

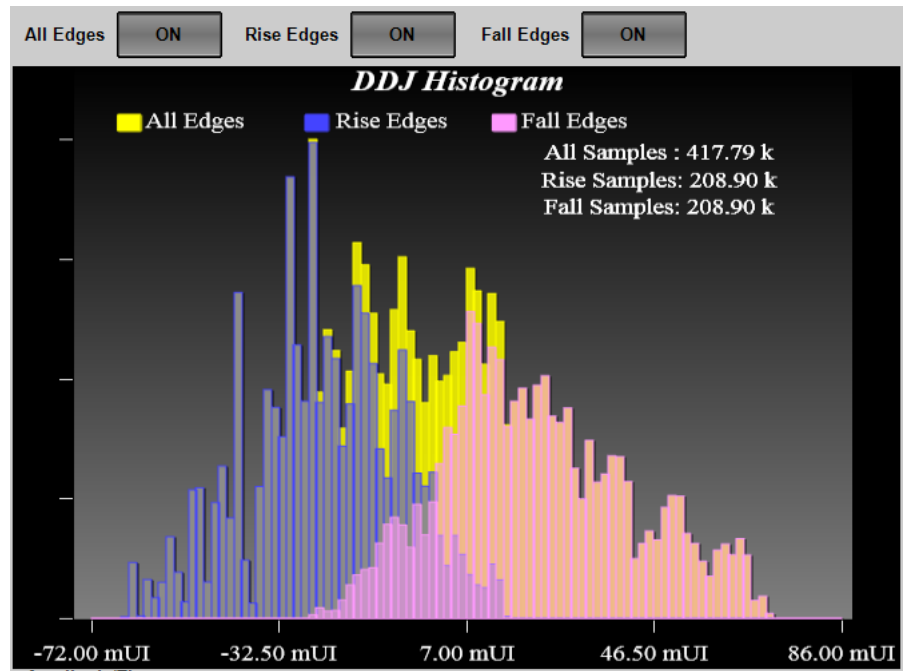

Figure 6.2.2.2-5 DDJ Histogram

Table 6.2.2.2-5 DDJ Histogram Item

Name	Description
All Edges	When the button display is ON , the histogram is displayed.
Rise Edges	
Fall Edges	
All Samples	The number of samples for the both edges histogram
Rise Samples	The number of samples for the rising edge histogram
Fall Samples	The number of samples for the falling edge histogram

PJ vs Frequency

When clicking **PJ vs Frequency** on the Graph selection buttons, spectrum of jitter is displayed.

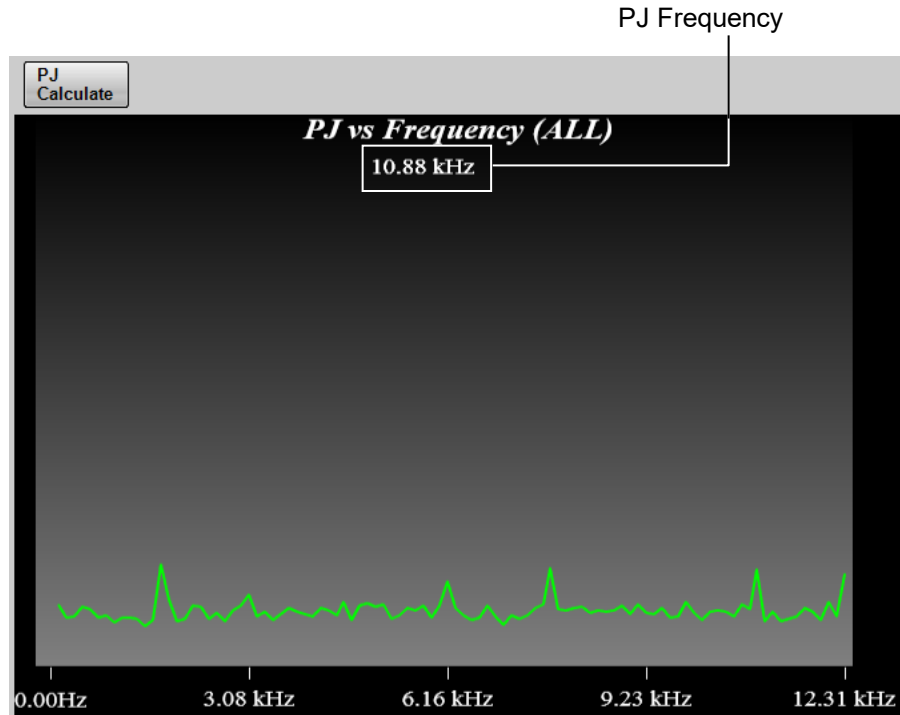

Figure 6.2.2.2-6 PJ vs Frequency

Table 6.2.2.2-6 PJ vs Frequency Item

Name	Description
PJ Calculate	Calculates the peak frequency of the jitter spectrum if the following condition is met: <ul style="list-style-type: none"> • Pattern Length is 2 and pattern data is "10".
(PJ Frequency)	Spectrum peak frequency

DDJ vs Bit

When clicking **DDJ vs Bit** on the Graph selection buttons, Pattern, and DDJ graph are displayed.

Notes:

- If PDJ measurement is **ON**, **DDJ vs Bit** changes to **PDJ vs Bit**.
- When the display range on the horizontal axis is 193 bits or more, the pattern graph (white line) is not displayed.

A red circle is displayed at the maximum position of the DDJ, and a blue circle marker is displayed at the position where the DDJ is at the minimum position.

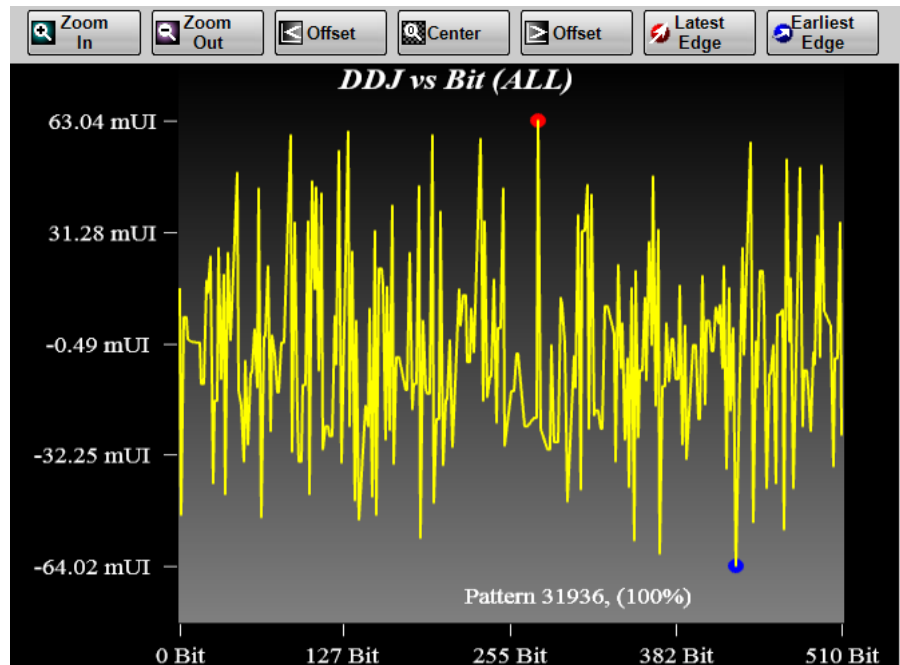

Figure 6.2.2.2-7 DDJ vs Bit

Table 6.2.2.2-7 DDJ vs Bit Item

Name	Description
Zoom In	Makes the display range of the graph half.
Zoom Out	Doubles the display range of the graph.
< Offset	Moves the display area of the graph to the left.
Center	Displays the entire range of the graph.
> Offset	Moves the display area of the graph to the right.
Latest Edge	Zooms in the location with the maximum jitter amount.
Earliest Edge	Zooms in the location with the minimum jitter amount.
Pattern	Displays the number of measured patterns and acquisition rate.

6.2.3 Setup Dialog Box

Click **Setup** shown in Figure 6.2.1-1, to display the Setup dialog box shown in Figure 6.2.3-1.

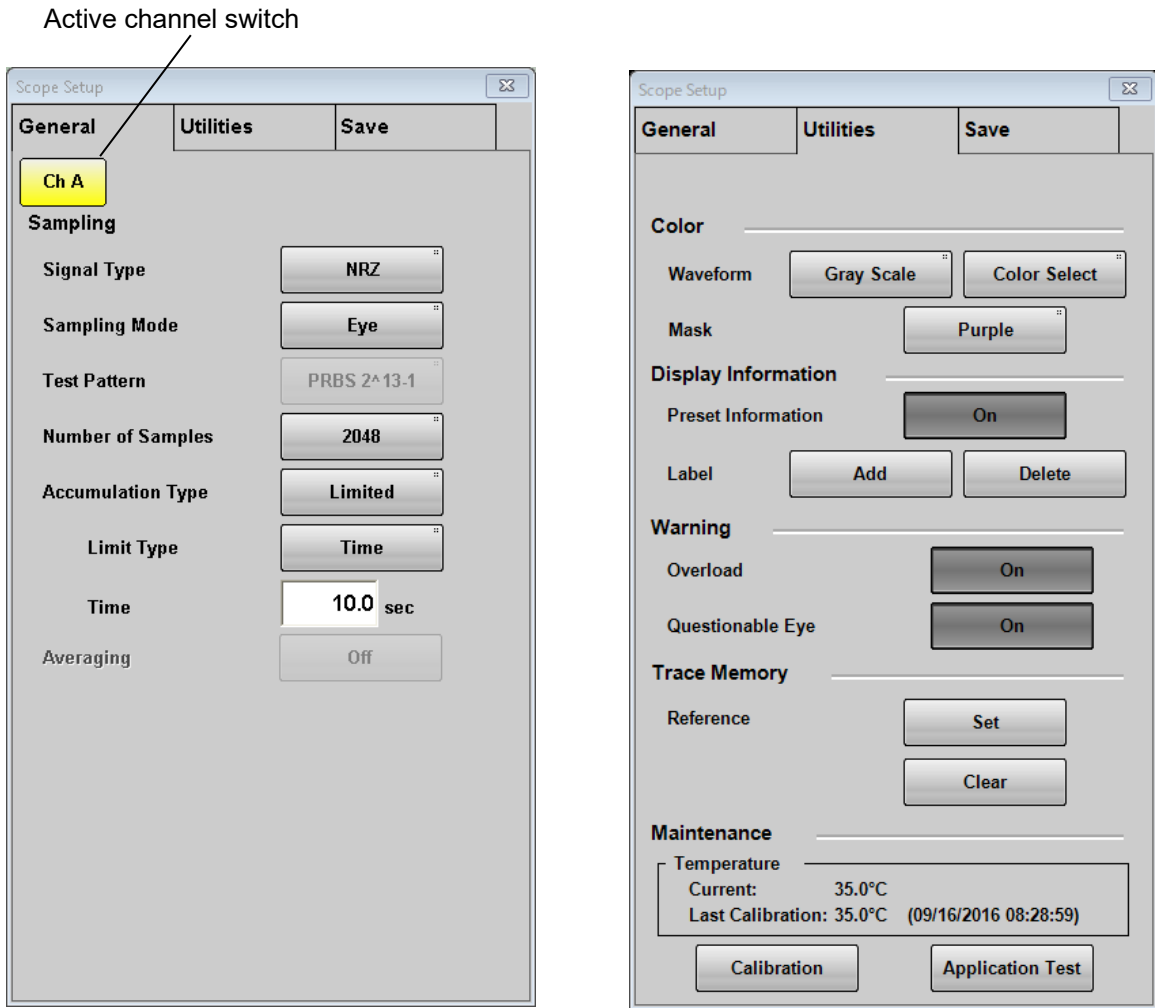

Figure 6.2.3-1 Setup Dialog Box (General, Utilities tab)

Table 6.2.3-1 Items of Setup Dialog Box (General tab)

Item	Description
Signal Type	When MP2110A-x95 is installed, select the type of signal (NRZ or PAM4). To measure jitter, select NRZ .
Sampling Mode*	Select sampling mode from Eye , Pulse , Coherent Eye , Advanced Jitter . Pulse , Coherent Eye can not measure jitter. For the jitter graph, see Table 6.2.3-4 “Sampling Mode Setting and Graph”.
Test Pattern	This is available when the MP2110A-x95 or MP2110A-x98 is installed. Select the pattern from Variable , PRBS2⁷⁻¹ , PRBS2⁹⁻¹ , PRBS2¹¹⁻¹ , PRBS2¹³⁻¹ , PRBS2¹⁵⁻¹ , SSPRQ . When Sampling Mode is Eye , it is set to Variable .
Number of Samples	Sets the number of samples. When Sampling Mode is set to Advanced Jitter , the number of samples is 8128.
Accumulation Type	Sets the accumulation method of the sampling data.
Limit Type	Select the sampling end condition from Time , Samples , Waveforms , or Pattern . The parameter corresponding to the selected type becomes available. Pattern can be selected when Sampling Mode is Pulse , Coherent Eye , or Advanced Jitter .
Time	Sets the sampling time.
Samples	Sets the number of samples.
Waveforms	Sets the waveforms. The number of samples is the product of Waveforms and Number of Samples. When Sampling Mode is set to Advanced Jitter , it is the number of waveform sweeps
Averaging	On : Performs averaging. This is available when one of the following conditions is met: <ul style="list-style-type: none"> • Sampling mode is Pulse • Sampling mode is Coherent Eye, and Test Pattern is other than Variable
Pattern	Set the number of patterns. The number of samples is automatically set by the product of the pattern length and the number of patterns.

*: When MP2110A-x96 is installed, **Advanced Jitter** is added to Sampling Mode.

Table 6.2.3-2 Items of Setup Dialog Box (Utilities tab)

Item	Description
Waveform	Selects the color of waveform from Color Grade or Gray Scale . It does not apply to jitter graphs. When Gray Scale is selected, click Color Select , and you can set the waveform color.
Mask* ¹	Selects the color of mask from Purple or Gray .
Preset Information* ¹	On: Displays the setting information (vertical axis/horizontal axis scale, offset, symbol rate, status of precision trigger (On/Off)) in the waveform display area. Off: Hides the setting information other than GND.
Label Add* ¹	Adds a new label.
Label Delete* ¹	Deletes the displayed label.
Overload	On: Displays a warning (Overload/Clipped) as shown in Figure 6.2.1-5 when the input signal level becomes excessively high. If a warning is displayed, N/A is displayed as a measurement result. Off: Does not display a warning (Overload/Clipped).
Questionable Eye	On: Displays N/A as a measurement result except for Average Power when NRZ? or PAM4? is displayed in the measurement result/marker display area. NRZ? and PAM4? indicate that the input signal may not be measured correctly (refer to Figure 6.9.1-3). However, in Version 7.02.10 or later, they are all displayed as N/A except for Average Power, Outer OMA/VMA, and Outer ExR. Off: Displays measurement results even when NRZ? or PAM4? is displayed.
Set Reference* ¹	Saves the displayed waveform as the reference trace.
Clear Reference* ¹	Deletes the reference trace.
Temperature	Displays the temperature of the sampling oscilloscope. Current: Displays the current temperature. Last Calibration: Displays the temperature at the last calibration, together with date and time.
Calibration* ²	Calibrates the amplitude level of the sampling oscilloscope.
Application Test* ²	Runs the self test for the sampling oscilloscope.

*1: If Sampling Mode is set to **Advanced Jitter**, the setting is not reflected.

*2: Operation is not possible when Sampling Mode is set to **Advanced Jitter**.

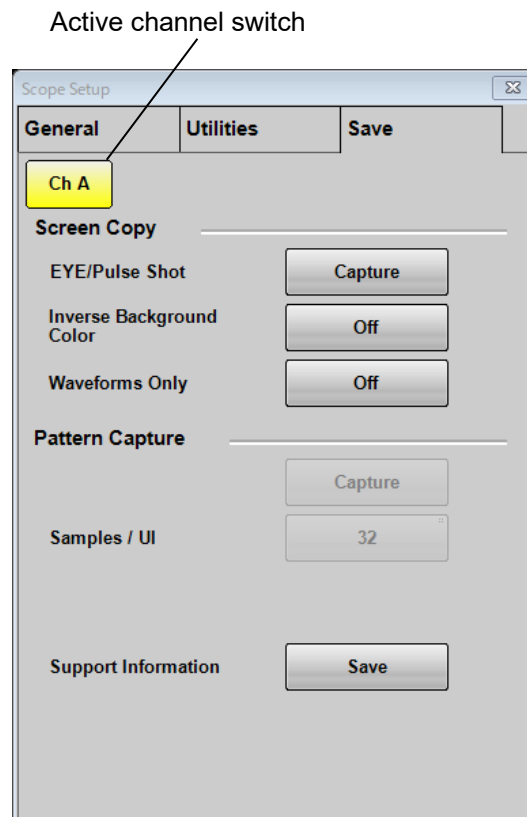

Figure 6.2.3-2 Setup Dialog Box (Save tab)

Table 6.2.3-3 Items of Setup Dialog Box (Save tab)

Item	Description
EYE/Pulse Shot	Clicking Capture saves the screen file in the result window.
Inverse Background Color	Sets the color of the save screen at EYE/Pulse Shot.
Waveforms Only	<p>On: Saves only the waveform displayed in the Result window to a file. The jitter graph is not saved.</p> <p>Off: Saves the whole Result window to a file. The jitter graph is not saved.</p>
Pattern Capture	<p>Clicking Capture captures amplitude data of one cycle of test pattern in the waveform being displayed and save it in a test file. This function is available when Sampling Mode is Coherent Eye and Test Pattern is other than Variable.</p> <p>The text file is saved to the following folder. C:\Users\Public\Documents\Anritsu\MX21000A\UserData\Result\TXT</p>
Samples / UI	Sets the number of times that the amplitude is measured per UI by Pattern Capture (number of samples).
Support Information	Clicking Save saves “BERTWaveSupportInformation.zip” on the desk top. This file includes information that could be useful for solving a problem. Attach the file when you inquire us about the MP2110A behavior.

Table 6.2.3-4 Sampling Mode Setting and Graph

Sampling Mode	Eye	Advanced Jitter
Graph to display	Bathtub (CHA)	Bathtub
	TJ Histogram (CHA)	DDJ Histogram
	Bathtub (CHB)	Composite Histogram
	TJ Histogram (CHB)	DDJ vs Bit
	Bathtub (CHC)	PJ vs Frequency
	TJ Histogram (CHC)	RJ/PJ Histogram
	Bathtub (CHD)	TJ Histogram
	TJ Histogram (CHD)	

Data to be captured by Pattern Capture

The following explains a file to be generated by executing **Pattern Capture** in the setting below.

Test Pattern: PRBS 2^9-1
 Samples / UI: 8

Because PRBS 2^9-1 bit length is $2^9-1 = 511$ and the sample number per UI is 8, the amplitude is measured at the position of 4088 ($= 511 \times 8$). The amplitude is measured at the positions indicated by \times and saved in a text file. The unit is mV or μW .

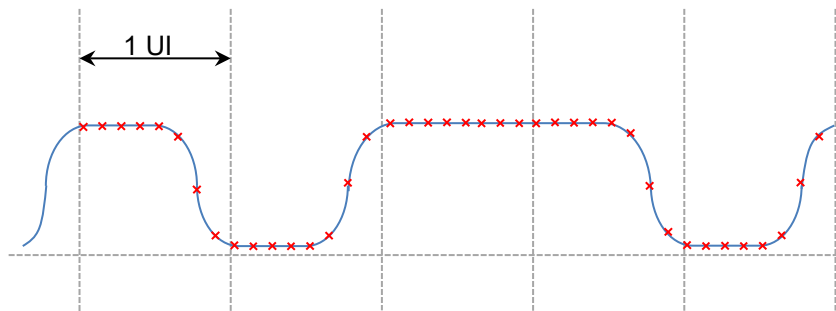

Figure 6.2.3-3 Samples per UI

6.2.4 Measure Dialog Box

When clicking **Measure** in the Figure 6.2.1-1 “Result Window”, the Measure dialog box shown in Figure 6.2.4-1 is displayed.

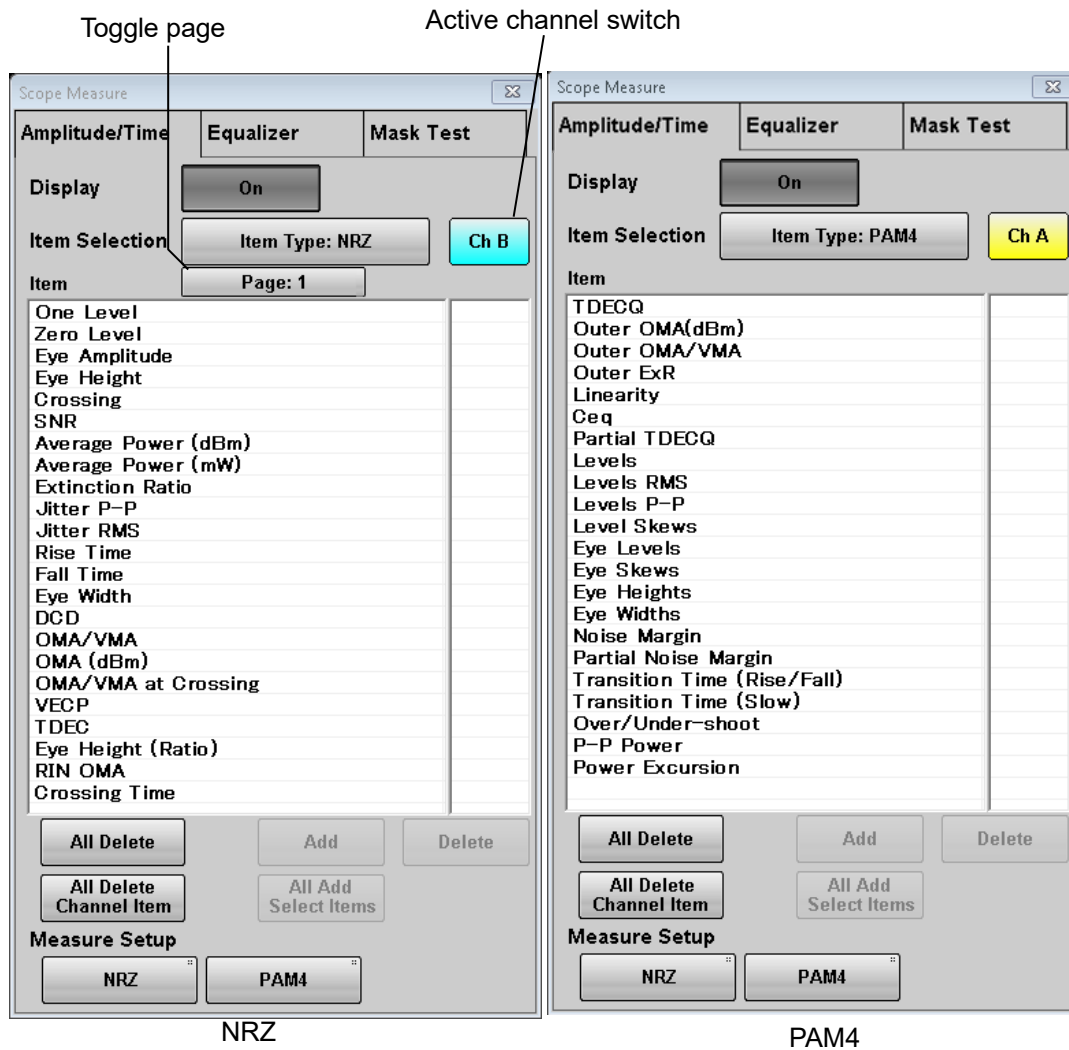

Figure 6.2.4-1 Measure Dialog Box - Amplitude/Time Tab (NRZ, PAM4)

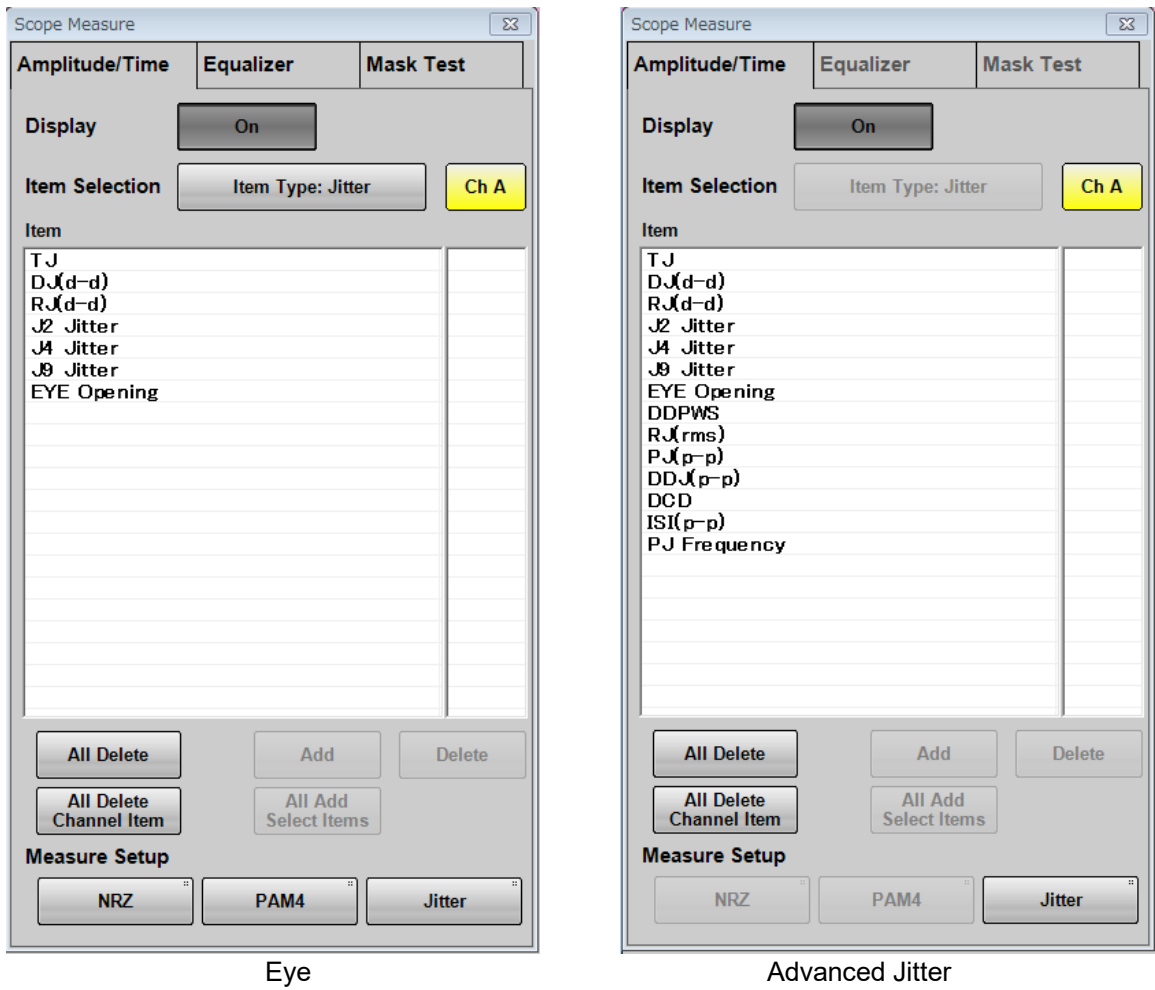

Figure 6.2.4-2 Measure Dialog Box - Amplitude/Time Tab (Jitter)

Table 6.2.4-1 Items of Amplitude/Time Tab

Item	Description
Display	On: Displays the Amplitude/Time measurement results in the Result window. Off: Does not display the Amplitude/Time measurement results in the Result window.
Item Selection	Select measurement items. When MP2110A-x95 or MP2110A-x96 is installed, a button to switch the display of measurement items is displayed. A toggle page button is displayed if there are many measurement items.
Item	To select an item or items you want to add or delete, click on the right column. Click on the selected item to deselect it. Multiple cells can be selected by dragging the mouse.
All Delete	Deletes all items.
All Delete Channel Item	Deletes all items for the selected channel.
Delete	Deletes the item(s) selected in the Item list for the selected channel.
All Add Select Items	Adds the item(s) selected in the Item list to all channels.
Add	Adds the item(s) to the Item list for the selected channel.
Measure Setup	Click the button to display the dialog box for setting the measurement condition. PAM 4 is displayed when MP2110A-x95 is installed. Jitter is displayed when MP2110A-x96 is installed.

Depending on options, the settings are restricted as follows:

MP2110A-x21

At Amplitude/Time in the Measure dialog box, the following measurement results are invalid values.

Signal Type	NRZ	PAM4
Measurement Item	Average Power (dBm), Average Power (mW), Extinction Ratio, OMA (dBm), RIN OMA	Outer OMA(dBm), Outer ExR, P -P Power, Power Excursion,

MP2110A-x95

When the MP2110A-x95 is installed, the RIN OMA and Ceq can be measured. They can be measured in both NRZ and PAM4 modes.

Clicking **NRZ** at Measure Setup displays the **Setup (NRZ Amplitude/Time)** dialog box.

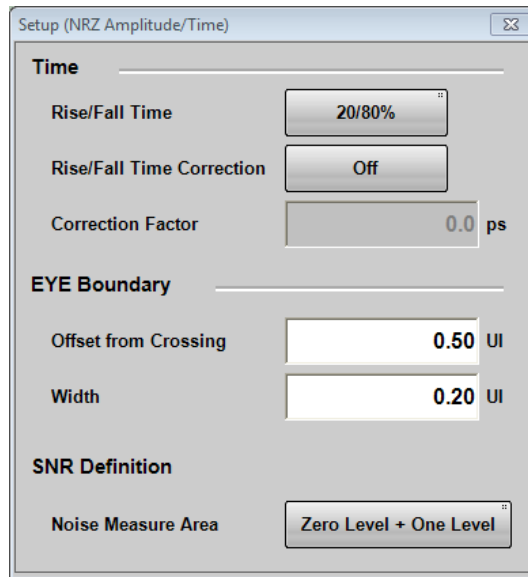

Figure 6.2.4-3 Setup (NRZ Amplitude/Time) Dialog Box

Table 6.2.4-2 Items of Setup (NRZ Amplitude/Time) Dialog Box

Item	Description
Rise/Fall Time	Sets the position to measure Rise Time and Fall Time.
Rise/Fall Time Correction	When setting to On , the Rise Time and Fall Time are corrected. *1 is displayed in the measured values of Rise Time and Fall Time.
Correction Factor	Sets the correction factor for Rise Time and Fall Time.
Offset from Crossing*	Sets the center position to measure One Level and Zero Level.
Width*	Sets the width for measuring One Level and Zero Level.
Noise Measure Area	Sets the position to measure noises of SNR.

*: Refer to “Figure 6.9.1.1-2 Setting Item of EYE Boundary”.

Clicking **PAM4** at Measure Setup displays the **Setup (PAM4 Amplitude/Time)** dialog box.

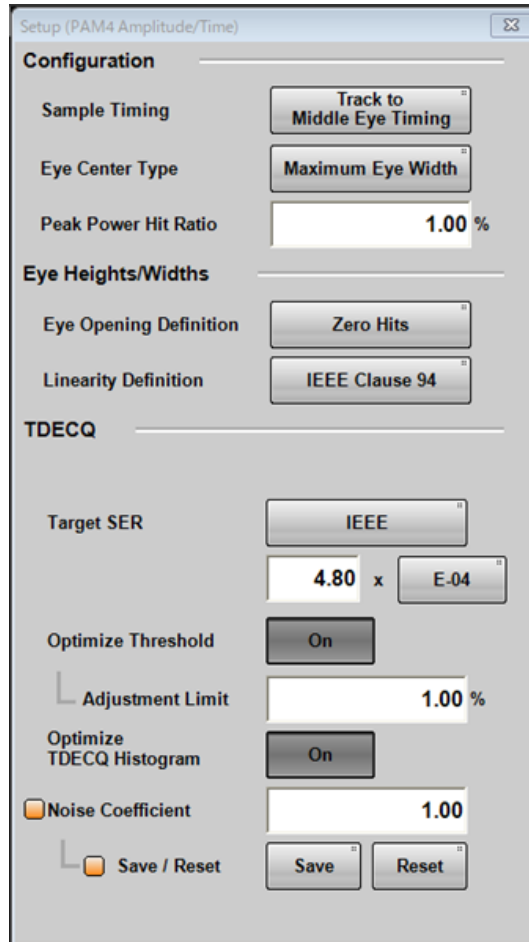

Figure 6.2.4-4 Setup (PAM4 Amplitude/Time) Dialog Box

The TDECQ equalizer is set on the Measure Dialog Box – Equalizer Tab (No.1, No.3) shown in Figure 6.2.4-9. When you see the following message, check the settings on the **General** tab of the Setup dialog box.

TDECQ settings can be selected only when set PAM4, Coherent Eye and Pattern.

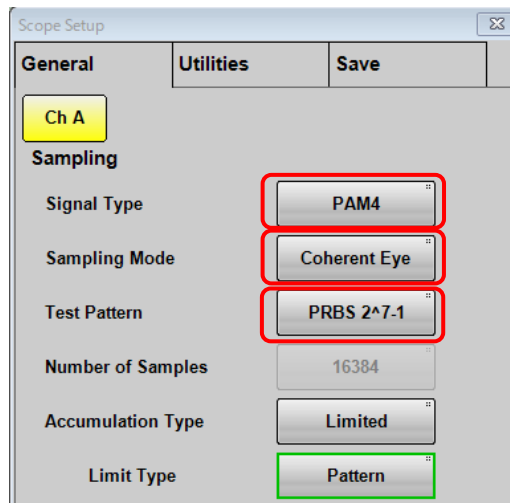

Figure 6.2.4-5 General Tab Settings for Measuring TDECQ

Table 6.2.4-3 Items of Setup (PAM4 Amplitude/Time) Dialog Box

Item	Description
Configuration	
Sampling Timing	Set the reference position of the upper eye and the lower eye. Track to Middle Eye Timing: Adjust to the center eye position. Refer to Figure 1.5-11. Independent Timing: The reference positions of the three eyes can be set separately. Refer to Figure 1.5-10.
Eye Center Type	Select the method to set the center position of the eye. Maximum Eye Width: Center of the amplitude at which Eye Width is the maximum. Maximum Eye Height: Center of the phase at which Eye Height is the maximum. <div style="display: flex; justify-content: space-around; text-align: center;"> <div> <p>Eye Center for Maximum Eye Width</p>  </div> <div> <p>Eye Center for Maximum Eye Height</p>  </div> </div>
Peak Power Hit Ratio*	Sets the threshold for determining the Peak Power by the ratio to the number of samples in 1 UI. If set to 1%, the position of 1% of the number of samples from the maximum value of the waveform is considered the maximum power (Pmax). Also, the position of 1% of the number of samples from the minimum value of the waveform is considered the minimum power (Pmin). The difference between Pmax and Pmin is considered Peak Power. If 0 is specified, the difference between maximum and minimum values of the waveform is considered Peak Power.

Table 6.2.4-3 Items of Setup (PAM4 Amplitude/Time) Dialog Box

Item	Description
Eye Heights/Widths	
Eye Opening Definition	Defines the eye opening. Zero Hits: The area where sampling does not occur. 1E-01 to 1E-06: The area that bit error is equal to or less than the specified value. 1E-01 means 10 ⁻¹ .
Linearity Definition	Select a definition of the Linearity measurement method from IEEE Clause 94 or IEEE Annex 120D .
TDECQ*	
Target SER	Select the standard for SER that determines the factor Qt used for TDECQ, among Variable , IEEE and FC . When Variable is selected, the value can be set at Target SER .
Optimize Threshold	When set to On , the measurement threshold is finely adjusted so that TDECQ can be optimized as specified in the IEEE 802.3cd. The amount of adjustment can be set in a range of 0 to ±10% with respect to the threshold defined in the IEEE 802.3cd. The threshold is optimized for Left Histogram and Right Histogram separately.
Adjustment Limit	Sets the amount of threshold adjustment.
Optimize TDECQ Histogram	On: Measures the optimized sample distribution for less effect of the low-frequent samples and better reproducibility of TDECQ measurement. Off: Uses the sampling distribution as is for measurement. All samples can be measured, but may be affected by less-frequent samples.
Noise Coefficient	Adjusts the retaining amount of noise aliased by the digital filter. Range: 0.00 to 2.00 If set to 1.00, the amount of noise does not change before and after filtering. If set to less than 1.00, the amount of noise becomes smaller after filtering. If set to larger than 1.00, the amount of noise becomes larger after filtering. In Version 7.04.19 or later, different values can be set for each channel.
Save	Saves the displayed value as the initial value of Noise Coefficient.
Reset	Discards the change to the initial value of Noise Coefficient and resets it to the factory default.

*: The settings are valid when all of the following conditions are met:
 Item Selection is **Item Type: PAM4**.
 Sampling Mode is **Coherent Eye**
 Test Patterns other than **Variable**

The following figure shows the positions of Pmax and Pmin when Peak Power Hit Ratio is set to 1%.

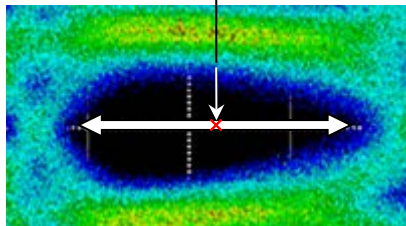
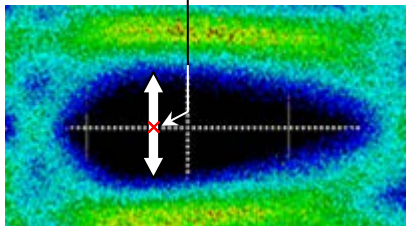
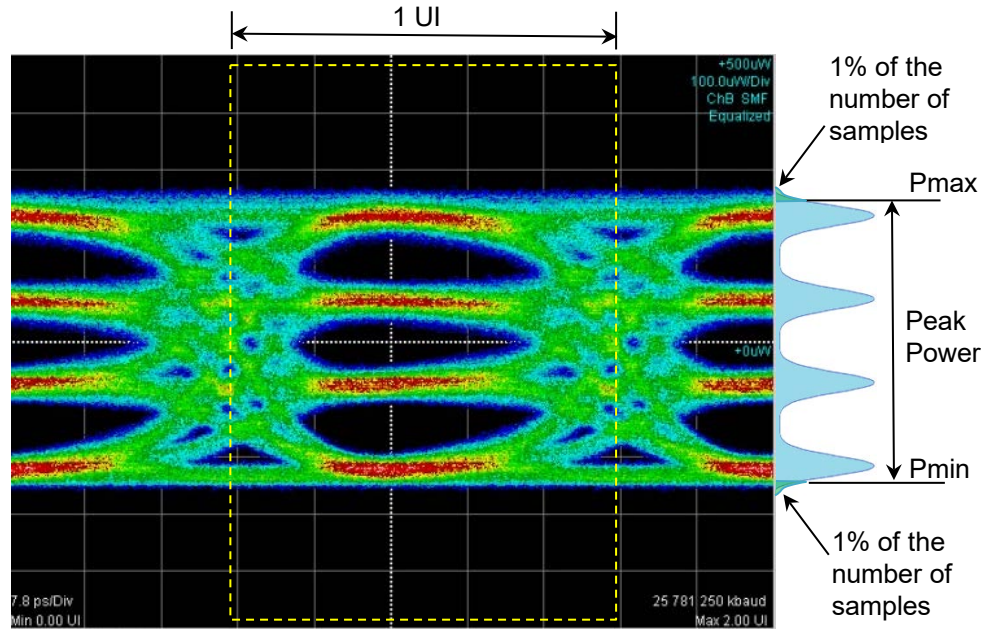

Figure 6.2.4-6 How to Determine Peak Power

Jitter Measure Dialog Box

Clicking **Jitter** at Measure Setup displays the **Jitter Measure** dialog box.

If Sampling in the Setup dialog box is **Advanced Jitter**, the **Algorithm** tab and **Advanced** tab are displayed in the **Jitter Measure** dialog box.

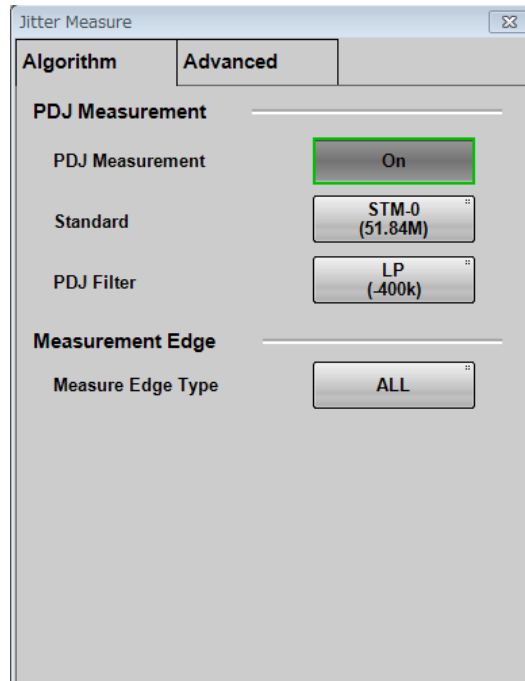

Figure 6.2.4-7 Jitter Measure Dialog Box - Algorithm Tab

Table 6.2.4-4 Items of Jitter Measure Dialog Box - Algorithm Tab

Item	Description
PDJ Measurement	Sets execution of PDJ measurement. PDJ (Pattern Dependent Jitter) is jitter measured by applying a band-pass filter to DDJ. On: Displays PDJ vs Bit graph. Off: Displays DDJ vs Bit graph.
Standard	Specify the standard used for PDJ measurement from the following. STM-0, STM-1, STM-4, STM-16, STM-64, STM-256
PDJ Filter	Set the combination of filters to be used for PDJ measurement from the following: LP, HP0+LP, HP1+LP, HP1'+LP, HP2+LP, HP+LP, HP'+LP, LP', HP0+LP'
Measurement Edge Type	Set edge detection method of pattern data from All, Falling or Rising. The name you set will be displayed in the graph.

Table 6.2.4-5 Settable Standards for PDJ Measurement and Filter Sets (Unit Hz)

Standard	PDJ Filter							
	HP0	HP1	HP1'	HP2	HP'	HP	LP	LP'
STM-0	10	100	–	20 k	–	12 k	400 k	–
STM-1	10	500	–	65 k	–	12 k	1.3 M	500
STM-4	10	1 k	–	250 k	–	12 k	5 M	1 k
STM-16	10	5 k	–	1 M	–	12 k	20 M	5 k
STM-64	10	20 k	10 k	4 M	50 k	12 k	80 M	20 k
STM-256	–	80 k	20 k	16 M	–	–	320 M	–

The jitter specification values specified in ITU-T G.825/Amd.1 Table 1 are shown in the following table.

Table 6.2.4-6 Maximum Permissible Jitter at Network Interfaces

Interface	Measurement bandwidth, –3dB frequencies (Hz)	Peak-to peak amplitude (U _{pp})
STM-1e (Notes 1, 2)	500 to 1.3 M	1.5
	65 k to 1.3 M	0.075
STM-1 (Note 3)	500 to 1.3 M	1.5
	65 k to 1.3 M	0.15
STM-4 (Note 3)	1 k to 5 M	1.5
	250 k to 5 M	0.15
STM-16 (Note 3)	5 k to 20 M	1.5
	1 M to 20 M	0.15
STM-64 (Note 3)	20 k to 80 M	1.5
	4 M to 80 M	0.15
STM-256 (Note 3)	80 k to 320 M	1.5
	16 M to 320 M	0.18
NOTE 1 – Electrical format CMI-encoded, according to G.703.		
NOTE 2 – For networks deployed with G.813 Option II clocks or G.812 Type II, III or IV clocks, STM-1 requirements apply to STM-1e.		
NOTE 3 – STM-1 1 UI = 6.43 ns		
STM-4 1 UI = 1.61 ns		
STM-16 1 UI = 0.402 ns		
STM-64 1 UI = 0.100 ns		
STM-256 1 UI = 0.025 ns		

When Sampling Mode of the Setup dialog box is **Advanced Jitter**, the **Advanced** tab is displayed in the **Jitter Measure** dialog box.

When Sampling Mode of the Setup dialog box is **Eye**, the settings on the **Advanced** tab can be configured for each channel.

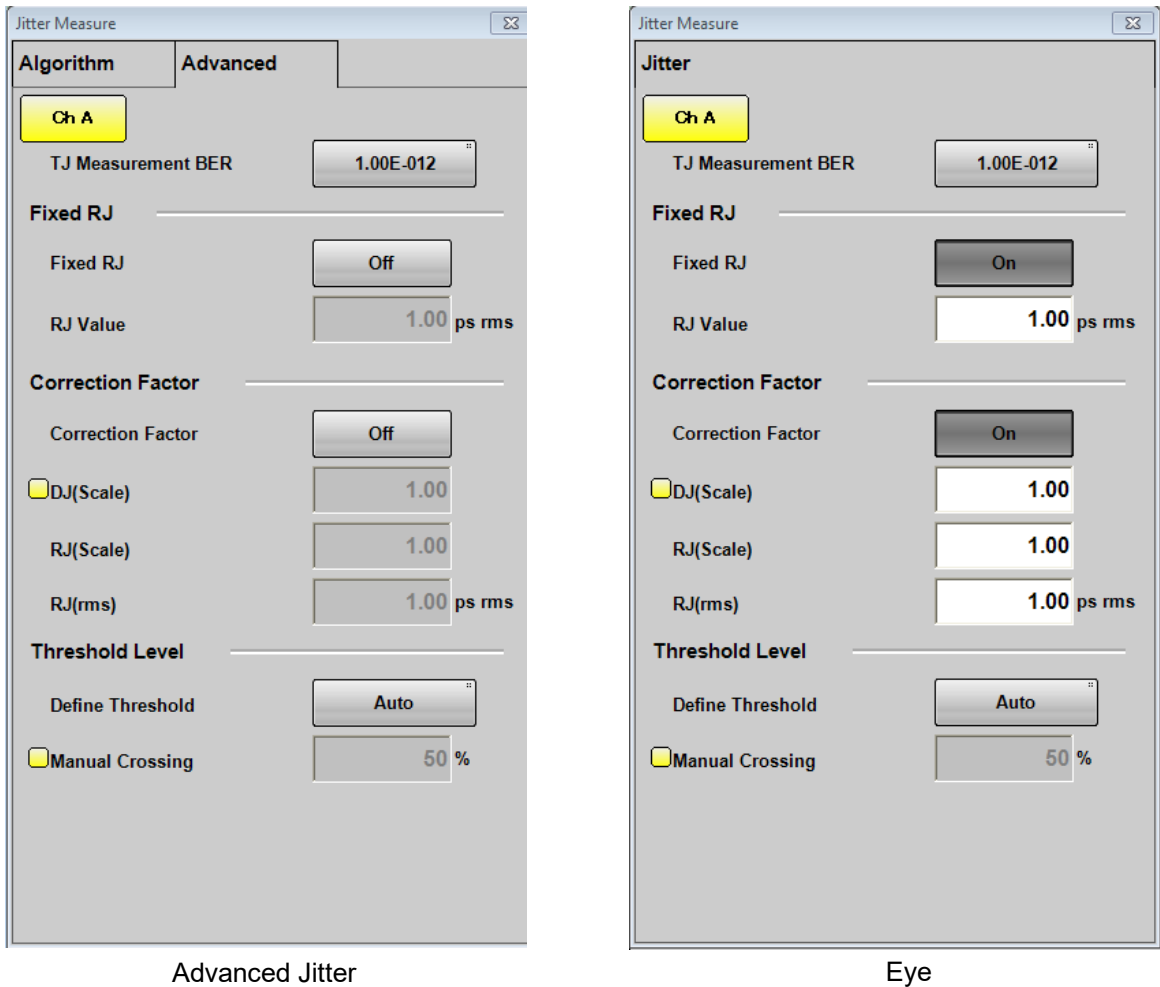
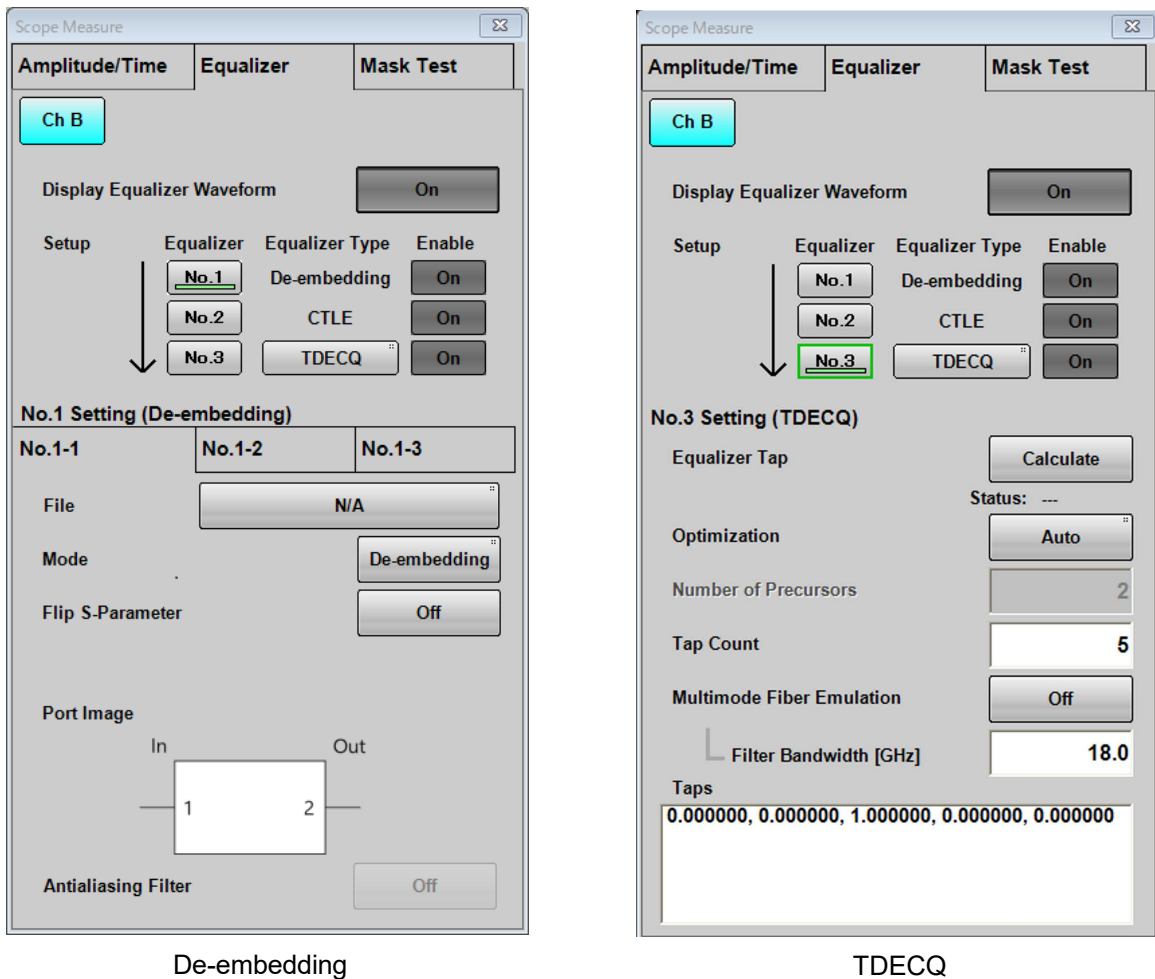

Figure 6.2.4-8 Jitter Measure Dialog Box - Advanced Tab

Table 6.2.4-7 Items of Jitter Measure Dialog Box - Advanced Tab

Item	Description
TJ Measurement BER	Sets the bit error rate to measure the eye opening in the Bathtub graph.
Fixed RJ	Set Off to display the graph using RJ calculated from the measured waveform. Set On to display TJ graph by setting RJ an arbitrary value. It is used to simulate the change of TJ by changing RJ value.
RJ Value	TJ is calculated with the use of the value entered here when Fixed RJ is set to On .
Correction Factor	When setting the display to On , DJ(Scale), the correction coefficients of RJ(Scale) and RJ(rms) can be entered. Corrected value(s) is(are) indicated by “*1” in the measurement result display area.
DJ (Scale)	It is the correction coefficient of DJ. The value calculated from the waveform multiplied by this number is displayed in the measurement result. Set to 1.00 for no correction.
RJ (Scale)	It is the correction coefficient of RJ. The value calculated from the waveform multiplied by this number is displayed in the measurement result. Set to 1.00 for no correction.
RJ (rms)	RJ (d-d), RJ (rms) correction coefficient. RJ is corrected with the following formula. $RJ = \sqrt{\sigma_m^2 - \sigma_r^2}$ σ_m : Standard deviation of measured RJ σ_r : Correction Coefficient RJ: RJ (d-d), RJ (rms) after correction. When not correcting, set Correction Factor to Off .
Define Threshold	Sets the position detection method of the cross point relative to the amplitude of the eye pattern. Set it to Auto for automatic detection and Manual to specify the position.
Manual Crossing	When Define Threshold is Manual , set the cross point position within the range of 30 to 70% of the amplitude.



De-embedding

TDECQ

Figure 6.2.4-9 Measure Dialog Box – Equalizer Tab (No.1, No.3)

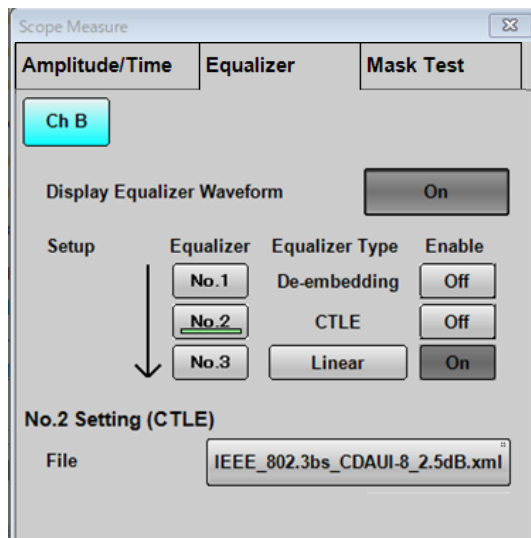

CTLE

Figure 6.2.4-10 Measure Dialog Box – Equalizer Tab (No.2)

When setting Sampling Mode to **Advanced Jitter** in the Setup dialog box, **Equalizer** tab and **Mask Test** tab cannot be operated.

Table 6.2.4-8 Items of Equalizer Tab*1

Item	Description
Display Equalizer Waveform	Off: Displays waveforms not applying Reference Equalizer. On: Displays waveforms applying Reference Equalizer.
Equalizer No.1 to 3*2	Select an Equalizer for which want to set the parameters. The selected Equalizer is indicated by a green underline. When No.1 is selected, up to three De-embedding settings can be made on separate tabs.
Equalizer Type*4	Equalizer No.1 is De-embedding, and Equalizer No.2 is CTLE. Equalizer No.3 is Reference Equalizer, which requires the method of automatic Tap calculation to be set. TDECQ *3: Calculates the Tap coefficients that optimize TDECQ. Linear *3: Calculates the Tap coefficients that increase the eye opening. For Linear , Number of Precursors must be specified. TDEC: Calculates the Tap coefficient that optimizes TDEC. (This is available only when Signal Type is NRZ .)
Enable*2	Turns on / off Equalizer No. 1 to 3.
De-embedding File*2	Select an s2p / s4p file to use for De-embedding. The files saved in the following folder are displayed. C:\Users\Public\Documents\Anritsu\MX210000A\UserData\DeEmbedding
De-embedding Mode*2	Embedding: Performs equalizer processing that adds s2p / s4p data characteristics. De-embedding: Performs equalizer processing that removes s2p / s4p data characteristics.
De-embedding Flip S-Parameter*2	Off: Does not reverse the I/O port definition of the s2p / s4p file. On: Reverses the I/O port definition of the s2p / s4p file.
De-embedding 4 Port Numbering*2	Sets the I/O port definition when the s4p file is loaded. 1↔2 3↔4: Port 1 to Port 2, and Port 3 to Port 4 1↔3 2↔4: Port 1 to Port 3, and Port 2 to Port 4

*1: The settings are valid when all of the following conditions are met:

Sampling Mode is **Coherent Eye**
Test Patterns other than **Variable**











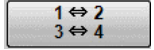
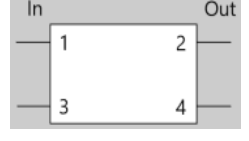
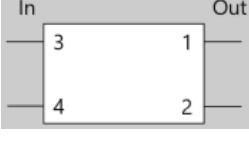

*2: For electrical channel, it can be set only when the MP2110A-x98 is installed.

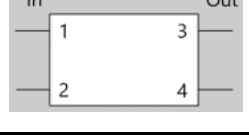
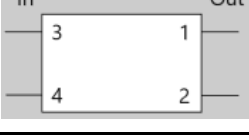
For optical channel, it can be set only when the MP2110A-x95 or MP2110A-x98 is installed.

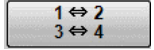
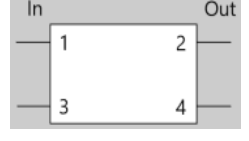
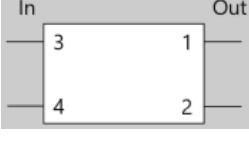
*3: Can be set when Signal Type is **PAM4**.

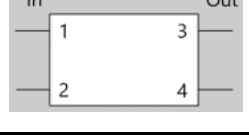
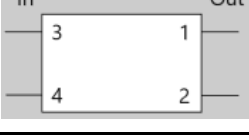
*4: Can be set only when the MP2110A-x95 is installed.

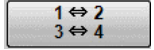
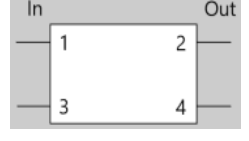
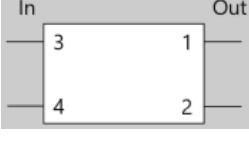
Table 6.2.4-8 Items of Equalizer Tab*1 (Cont'd)

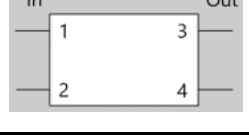
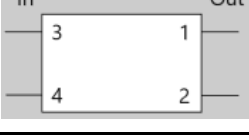
Item	Description														
De-embedding Port Image*2	<p>The I/O port definition of the s2p / s4p file is illustrated.</p> <table border="1" data-bbox="497 488 1369 1055"> <thead> <tr> <th data-bbox="497 488 810 584" rowspan="2">File, 4Port Numbering</th> <th colspan="2" data-bbox="810 488 1369 537">Flip S-Parameter</th> </tr> <tr> <th data-bbox="810 537 1091 584">Off</th> <th data-bbox="1091 537 1369 584">On</th> </tr> </thead> <tbody> <tr> <td data-bbox="497 584 810 745">N/A or when an s2p file is selected</td> <td data-bbox="810 584 1091 745">  </td> <td data-bbox="1091 584 1369 745">  </td> </tr> <tr> <td data-bbox="497 745 810 907">When an s4p file is loaded and  is selected</td> <td data-bbox="810 745 1091 907">  </td> <td data-bbox="1091 745 1369 907">  </td> </tr> <tr> <td data-bbox="497 907 810 1055">When an s4p file is loaded and  is selected</td> <td data-bbox="810 907 1091 1055">  </td> <td data-bbox="1091 907 1369 1055">  </td> </tr> </tbody> </table>	File, 4Port Numbering	Flip S-Parameter		Off	On	N/A or when an s2p file is selected			When an s4p file is loaded and  is selected			When an s4p file is loaded and  is selected		
File, 4Port Numbering	Flip S-Parameter														
	Off	On													
N/A or when an s2p file is selected															
When an s4p file is loaded and  is selected															
When an s4p file is loaded and  is selected															
De-embedding Antialiasing Filter*2	<p>Off: Does not apply Antialiasing Filter to the band outside the frequency range described in the s2p / s4p file.</p> <p>On: Applies Antialiasing Filter to the band outside the frequency range described in the s2p / s4p file.</p>														
CTLE File*5	<p>Select the file to use for CTLE. The files saved in the following folder are displayed.</p> <p>C:\Users\Public\Documents\Anritsu\MX21000A\UserData\CTLE</p>														
Equalizer Tap*4	<p>Calculate: Calculates the Tap coefficients of Reference Equalizer automatically.</p> <p>The result of automatic calculation is displayed as Pass (success) or Fail (failure).</p> <p>When the calculation is executed during Sampling HOLD, the waveform and measurement result of one pattern are displayed after the calculation is complete. When the calculation result is Fail, the Tap coefficients are initialized (main cursor is reset to 1, others are reset to 0).</p>														
Optimization*4	<p>Sets the mode to calculate the Tap coefficients for Reference Equalizer.</p> <p>Auto: Calculates the Tap coefficients more accurately.</p> <p>Fast: Calculates the coefficients in a shorter time than Auto.</p>														
Number of Precursors*4	<p>Sets the position of Main tap. This is available when Optimization is Fast.</p>														
Tap Count*4	<p>Can be set within the range of 3 to 21.</p>														
Multimode Fiber Emulation*4	<p>On: Displays the waveform that reproduces the mode dispersion of multimode fiber.</p>														
Filter Bandwidth	<p>Sets the bandwidth of the fiber emulation filter.</p>														

*5: Can be set only when the MP2110A-x98 is installed.

Table 6.2.4-8 Items of Equalizer Tab*1 (Cont'd)

Item	Description
Taps*4, *6	Enter the taps with a comma-separated string. Set the coefficient of each Tap within the range of -2.000000 to 2.000000.

*6: The number displayed depends on the setting of Tap Count.

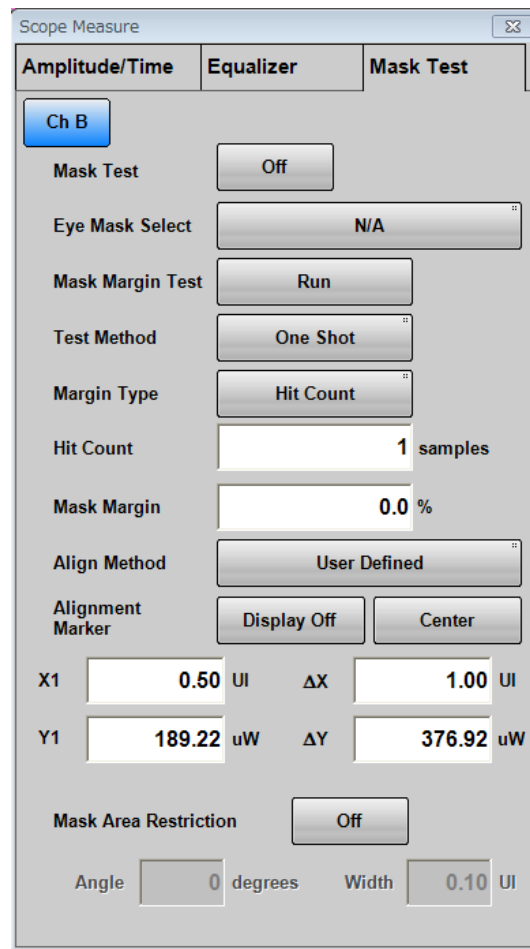

Figure 6.2.4-11 Measure Dialog Box - Mask Test Tab

When setting Sampling Mode to **Advanced Jitter** in the Setup dialog box, **Equalizer** tab and **Mask Test** tab cannot be operated.

Table 6.2.4-9 Items of Mask Test Tab

Item	Description
Mask Test	Turns on and off the mask test on the specified channel. This is set to Off in the following cases: <ul style="list-style-type: none"> • Signal Type of the channel is set to PAM4. • Sampling Mode is set to Advanced Jitter. • Sampling Mode is Coherent Eye and Test Pattern is set to other than Variable.
Eye Mask Select	Select the Mask type. Refer to “Table 6.9.2-1 Mask List”.
Mask Margin Test	Click Run to measure Mask Margin and then stop sampling.
Test Method	Continuous: Measures Mask Margin continuously. One Shot: Measures Mask Margin when Run is clicked for Mask Margin Test. The Mask Margin measurement is performed so that the failed samples will be under the value specified at Margin Type.
Margin Type	Selects the method to define the number of failed samples allowed in Mask Test. Hit Count: Defined by the number of failed samples. Hit Ratio: Defined by the ratio of failed samples to total samples/UI. Judged as “Pass” when the number of failed samples is under the specified value. When Hit Count is 1 (default), failed samples are not allowed.
Mask Margin	Sets Mask Margin. When Mask Margin is measured, it is updated to the measured value.
Align Method	Set the method of mask position setting. Zero/One/Crossing: Places the mask at the midpoint between 0 level and 1 level and at the midpoint between two waveform crossing points. This alignment is performed when Update is clicked for Mask Alignment or when the Limited measurement ends. User Defined: The user sets the position of the mask.
Alignment Marker	It is displayed when Align Method is User Defined . Display Off, Display On: Switches marker display. Center: Moves the mask to the center of the waveform display area.
X1, ΔX, Y1, ΔY	When Align Method is User Defined , the mask position and width are set. Refer to “Figure 6.9.2-3 Example of Adjusting Mask Position Manually”.
Mask Alignment	It is displayed when Align Method is Zero/One/Crossing . Click Update to update the mask position.
Mask Area Restriction	When setting to On , Angle and Width can be set and the mask area can be restricted. Refer to “Figure 6.9.2-4 Example of Limiting Mask Area”.

6.2.5 Amplitude O/E Dialog Box

When you click **Amplitude O/E** in the Result Window shown in Figure 6.2.1-1, you will see the Amplitude dialog box (one of Figure 6.2.5-1 to Figure 6.2.5-3) that corresponds with your system configuration. The **O/E** tab is displayed if the MP2110A is provided with optical input connector(s).

The setting items effective only for the active channel are indicated by the same color as the active channel.

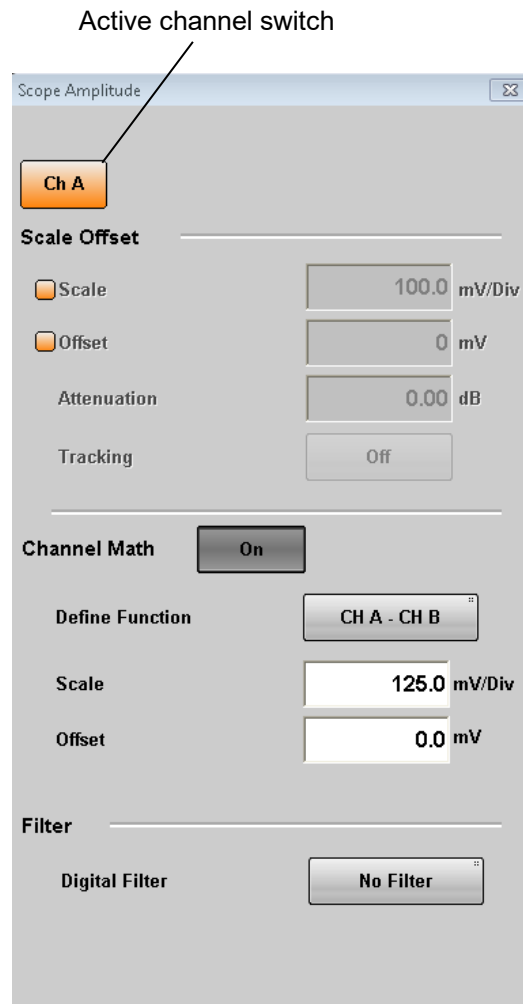

Figure 6.2.5-1 Amplitude Dialog Box (When MP2110A-x21)

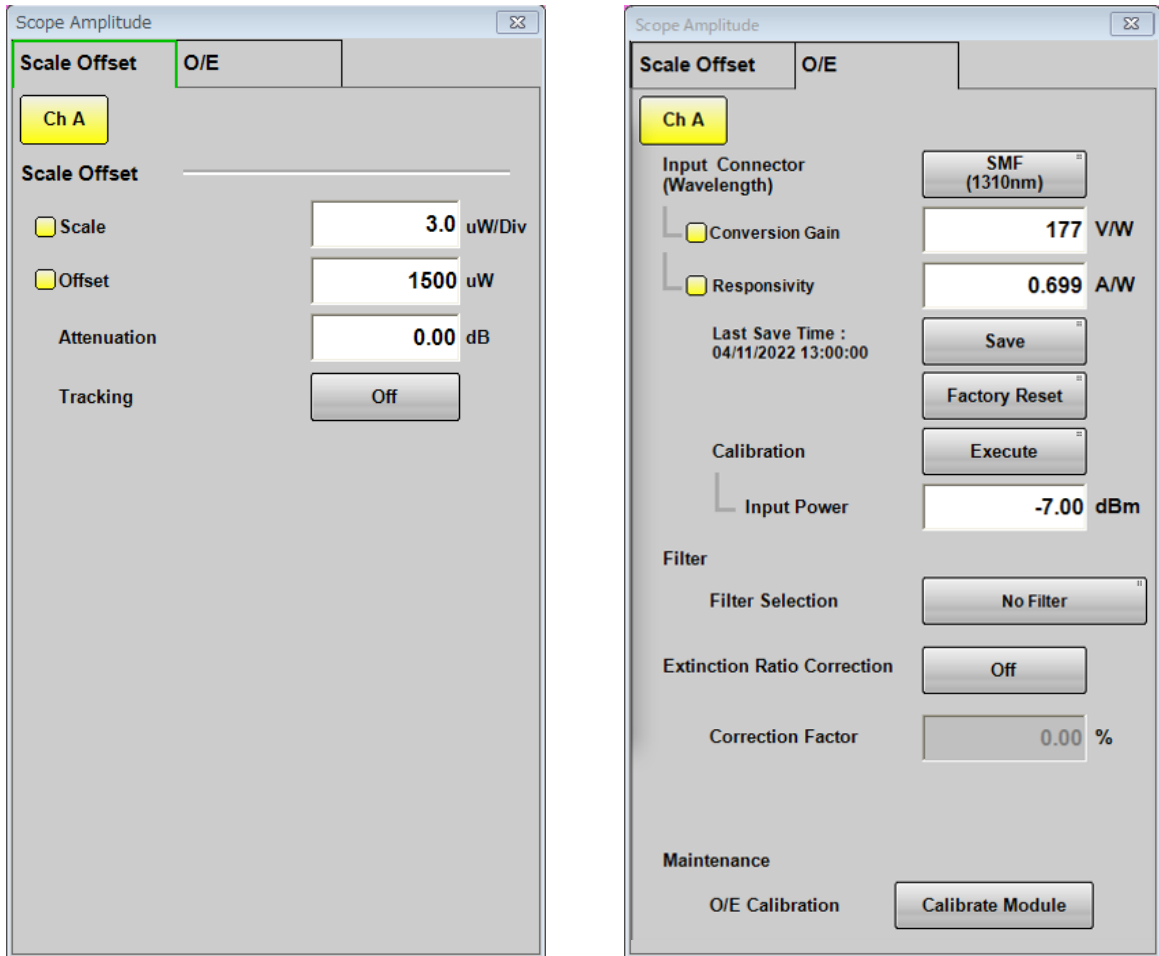

Figure 6.2.5-2 Amplitude Dialog Box (When MP2110A-x22, x30, x32, x39, x40, x42, and x49)

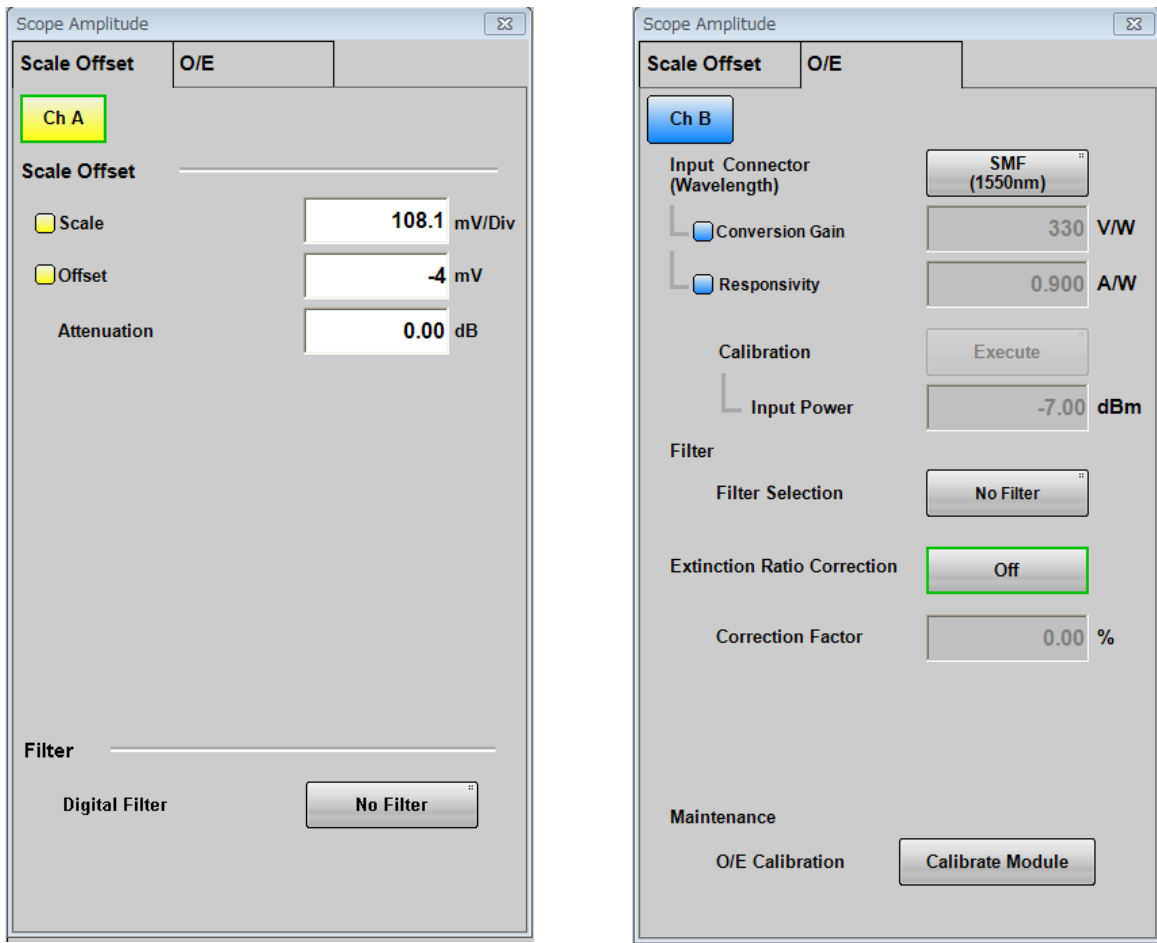

Figure 6.2.5-3 Amplitude Dialog Box (When MP2110A-x23, x33, and x43)

Table 6.2.5-1 Items of Amplitude Dialog Box

Tab	Item	Description
Scale Offset	Scale Offset	Sets the level scale.
	Scale	Sets vertical scale.
	Offset	Sets vertical offset.
	Attenuation	Sets attenuation amount for external attenuation.
	Tracking	Off: Sets the scale for the active channel. On: Sets the scale for all channels to the same value.
	Channel Math* ¹	Off: Displays waveforms for Channel A and B separately. On: Calculates waveforms for Channel A and B, and then that calculated result is displayed as Channel A.
	Define Function* ¹	Sets calculation method between channels.
	Scale	Sets vertical scale for calculation result between channels.
	Offset	Sets vertical offset for calculation result between channels.
	Digital Filter* ¹	When MP2110A-x98 is installed, electrical signal filters are added. Since these filters use digital signal processing, they can be used under the following conditions: <ul style="list-style-type: none"> • Sampling Mode is set to Coherent Eye • Test Pattern is set to other than Variable

*1: When Sampling Mode is set to **Advanced Jitter**, it can be operated while stopping measurement.

Table 6.2.5-1 Items of Amplitude Dialog Box (Cont'd)

Tab	Item	Description
O/E	Input Connector (Wavelength)*1, *2	Select the wavelength of input light from the following: MMF connector: 850 nm, User 1-4 SMF connector: 1310 nm, 1550 nm, 850 nm*3, 850 nm VCSEL*3, User 1-4
	Conversion Gain*2	Indicates the conversion ratio of the O/E. The setting range is from 1 to 9999 (V/W).
	Responsivity*2	Rate at which photodiode converts optical power to current The setting range is from 0.001 to 65.535 (A/W).
	Save	Saves the values of Conversion Gain and Responsivity as initial values. To reset the values of Conversion Gain and Responsivity to the values saved here, click Initialize .
	Factory Reset	Resets the values of Conversion Gain and Responsivity of the currently selected wavelength to the factory defaults. (Appendix B).
	Last Save Time*4	Displays the date and time the initial values were last saved with Save on the O/E tab. If you do a factory reset, this item becomes hidden.
	Calibration*2	Automatically adjusts the values of Conversion Gain and Responsivity when Wavelength is User 1-4 .
	Input Power*2	Setting used when performing calibration of Conversion Gain and Responsivity. Sets the average power of the input optical signal when performing calibration.
	Filter Selection*1	When MP2110A-x95 or MP2110A-x98 is installed, the digital filters are added. Since these filters use digital signal processing, they can be used under the following conditions. <ul style="list-style-type: none"> • Sampling Mode is set to Coherent Eye • Test Pattern is set to other than Variable
	Extinction Ratio Correction	Sets whether to correct the Extinction Ratio measurement. This correction is applied to the results of Extinction Ratio and Outer ExR
	Correction Factor	Indicates the correction factor of Extinction Ratio. The setting range is from -9.99 to 9.99%. Extinction Ratio is corrected using the following formula: $\text{Corrected Extinction Ratio (dB)} = -10 \log \left(\frac{1}{10^{\left(\frac{\text{Extinction Ratio (dB)}}{10} \right)}} - \frac{\text{Correction Factor (\%)}}{100} \right)$ For the Extinction Ratio (dB) formula, refer to Extinction Ratio or Outer ExR in 1.5, "Technical Terms".
	O/E Calibration	Starts module calibration.

*2: When **850nm**, **850nm VCSEL**, **1310nm**, or **1550nm** is selected at Wavelength, the values calibrated before factory shipment are set at **Conversion Gain** and **Responsivity**.

To measure an optical signal at the other wavelength or to change the factory adjustment values, refer to 6.3.3, “Adjusting Values for Changing the Wavelength Bands”.

When saved with **Save** of System Menu, the values of Conversion Gain and Responsivity are also saved.

- *3: When MP2110A-x61 is installed. Selecting **850nm** uses factory adjustment values with a DFB laser. Selecting **850nm VCSEL** uses factory adjustment values with a specific VCSEL laser.
- *4: When saved with **Save** of System Menu, the date and time display is not updated.

Depending on options, the settings are restricted as follows:

Channel Math is displayed in the Amplitude dialog box of the MP2110A-x21 only.

6.2.6 Time CRU Dialog Box

When clicking **Time CRU** in Figure 6.2.1-1 “Result Window”, Time dialog box shown in Figure 6.2.6-1 is displayed.

When MP2110A-x54 or MP2110A-x55 is installed, the **CRU** tab is displayed. When both options are installed, the **CRU(26G)** and **CRU(53G)** tabs are displayed.

The setting items effective only for the active channel are indicated by the same color as the active channel.

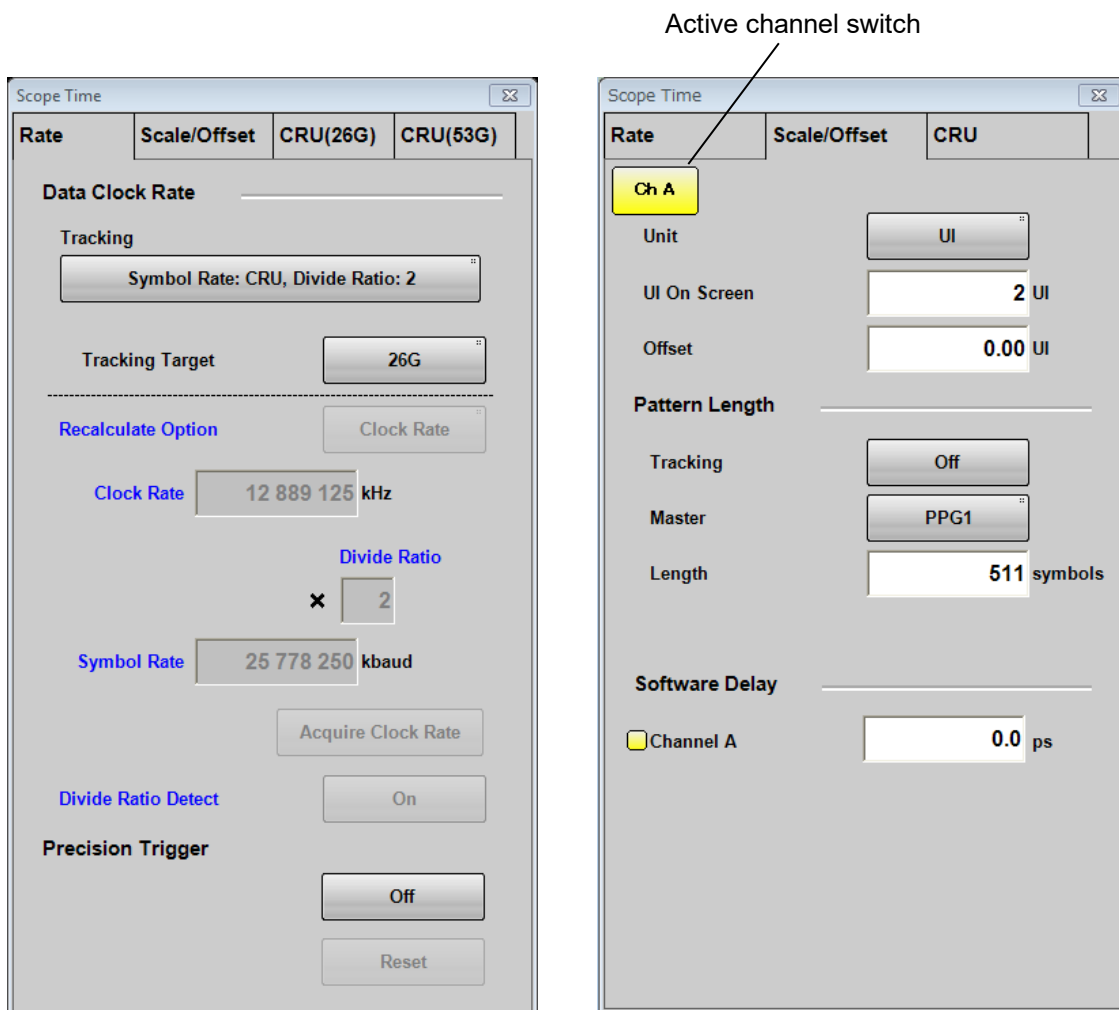

Figure 6.2.6-1 Time Dialog Box (Rate Tab, Scale/Offset Tab)

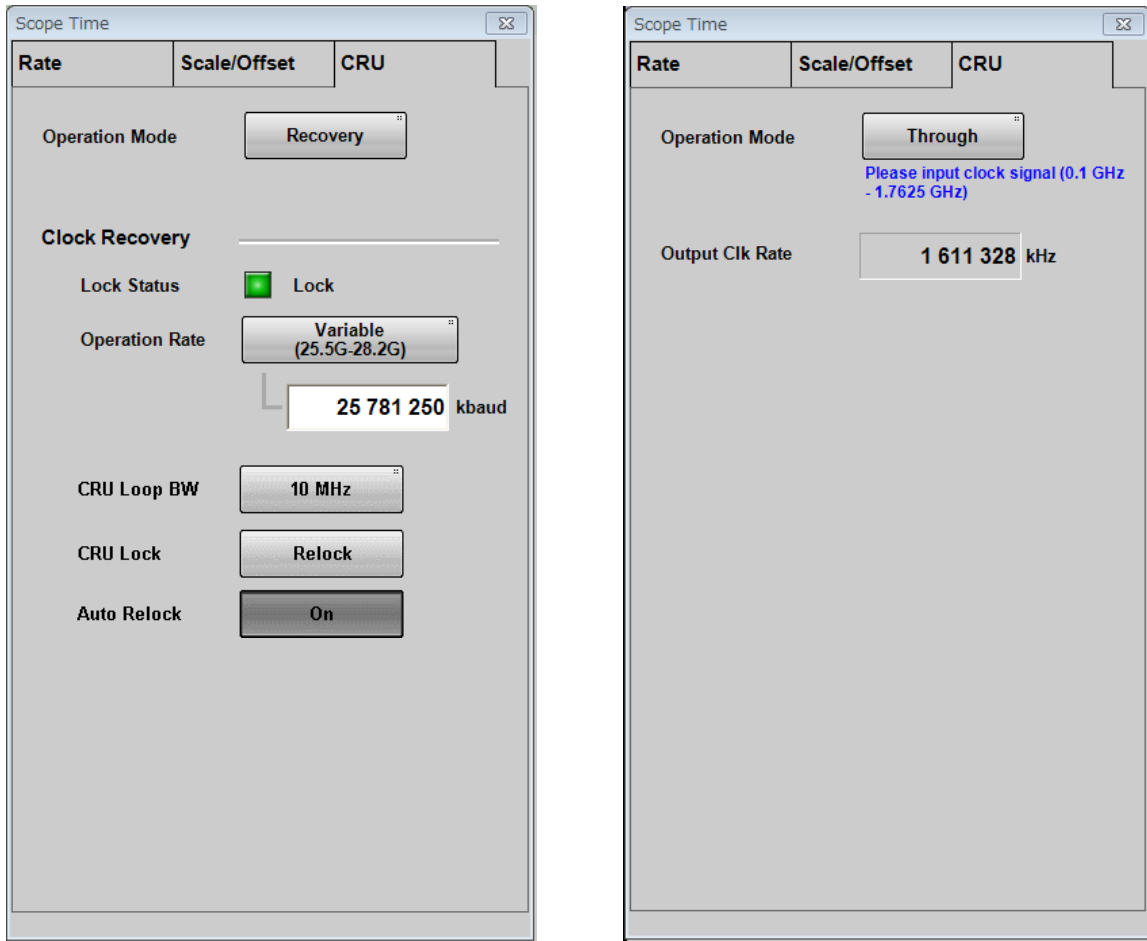

Figure 6.2.6-2 Time Dialog Box (CRU Tab) (When MP2110A-x54 is installed)

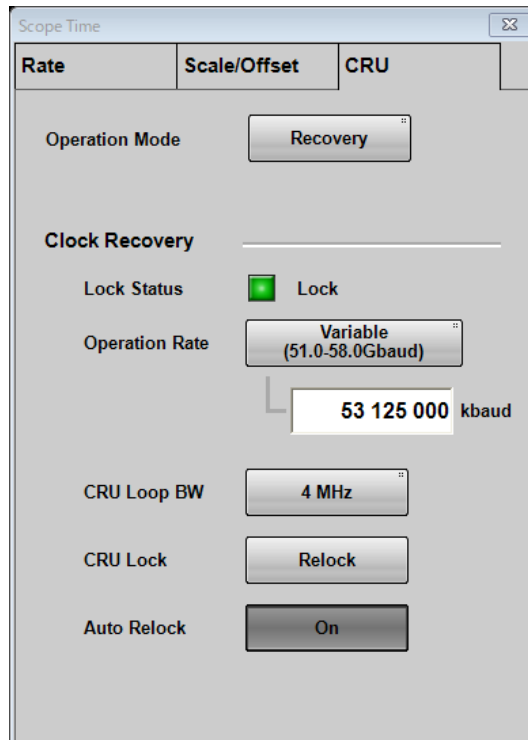

Figure 6.2.6-3 Time Dialog Box (CRU Tab)
(When MP2110A-x55 is installed)

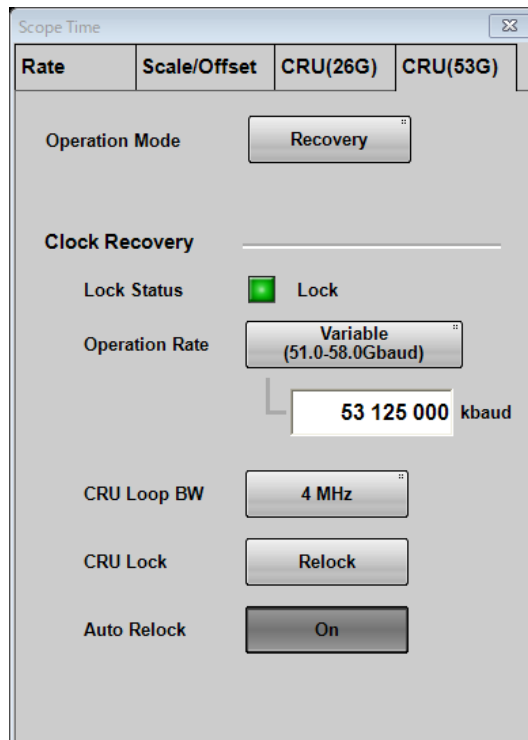

Figure 6.2.6-4 Time Dialog Box (CRU Tab)
(When MP2110A-x54 and MP2110A-x55 are installed)

Table 6.2.6-1 Items of Time Dialog Box

Tab	Item	Description
Rate	Data Clock Rate	Sets input data speed, clock frequency, and frequency dividing rate.
	Tracking* ¹	Specifies Symbol Rate whether to follow the Bit Rate of PPG/ED Ch1. Off: Symbol Rate does not follow PPG Bit Rate nor CRU Rate. Symbol Rate: PPG, Divide Ratio: Clock Output: Symbol Rate follows PPG Bit Rate. Divide Ratio follows PPG Clock Out. Symbol Rate: PPG, Divide Ratio: Sync Output: Symbol Rate follows PPG Bit Rate. Divide Ratio follows PPG Sync Out. Symbol Rate: PPG, Divide Ratio: User Defined: Symbol Rate follows PPG Bit Rate. Symbol Rate: CRU: 2*²: Symbol Rate follows CRU Rate. Divide Ratio is determined as follows, depending on which CRU to track and its setting. MP2110A-x54: 2 MP2110A-x55: 4 when the operation rate is 20G band. 8 when the operation rate is 50G band.
	Tracking Target* ³	Sets which CRU to track the setting when Symbol Rate: CRU is selected for Tracking. 26G: 26G CRU 53G: 53G CRU
	Recalculate Option	Clock Rate: Calculates Clock Rate from Symbol Rate and Divide Rate. Symbol Rate: Calculates Symbol Rate from Clock Rate and Divide Rate.
	Clock Rate	Sets clock frequency input to Trigger Clk In connector.
	Divide Ratio	Sets frequency dividing rate (Symbol Rate/Clock Rate).
	Symbol Rate	When Tracking is Off , Sets signal symbol rate to be measured.
	Acquire Clock Rate	Measures clock frequency input to Trigger Clk In connector.
	Divide Ratio Detect	Sets whether to detect frequency dividing ratio of clock signal input to Trigger Clk In connector. The automatic detection of the dividing ratio and the Divide Ratio resetting are preformed when this item is set to On or Auto Scale is executed.
	Precision Trigger* ⁴	
	On, Off	Enables or disables the precision trigger.
	Reset	Resynchronizes the trigger when the precision trigger is set to On.

*1: An error message is displayed because the Tracking operation is not performed when one or both of the following conditions is/are met.

- When Reference Clock of PPG is set to **External**, Tracking is set to other than **Off**.
 - When Clock Out of PPG is set to **Off**, Tracking is set to **Clock Out**.
- *2: When MP2110A-x54 or MP2110A-x55 is installed
 *3: When MP2110A-x54 and MP2110A-x55 are installed
 *4: When MP2110A-x24 is installed

Table 6.2.6-1 Items of Time Dialog Box (Cont'd)

Tab	Item	Description												
Scale/Offset	Unit	Sets units of horizontal axis on Waveform display area.												
	UI On Screen	Sets the scale on the horizontal axis of the Waveform display area as the number of unit intervals.												
	Offset*5	Sets time on left side of Waveform display area.												
	Pattern Length	Sets input data pattern length.												
	Tracking	Off : Allows you to directly set the pattern length in the Length box. On : Sets pattern length selected at Master to Length.												
	Master	Selects the item that reflects the pattern length.												
	Length	Sets the pattern symbol length. If the Test Pattern of the General tab in the Setup dialog box is Variable , specify the symbol length.												
	Software Delay	Sets time offset. Setting positive values moves the waveform to the right. Setting negative values moves the waveform to the left.												
CRU, CRU(26G), CRU(53G)	Operation Mode	Selects the operation of the clock recovery unit. <table border="1" style="width: 100%; border-collapse: collapse;"> <thead> <tr> <th style="width: 15%;">Operation Mode</th> <th style="width: 35%;">MP2110A-x54</th> <th style="width: 50%;">MP2110A-x55</th> </tr> </thead> <tbody> <tr> <td>OFF</td> <td>Clock is not output from the CRU Out connector.</td> <td>Clock is not output from the Recovered Clock Out connector.</td> </tr> <tr> <td>Recovery</td> <td>The clock recovered from the data signal input to the CRU In connector is output to the CRU Out connector.</td> <td>The clock recovered from the data signal input to the Optical SMF Data In connector is output to the Recovered Clock Out connector.</td> </tr> <tr> <td>Through</td> <td>The data signal input to the CRU In connector is output to the CRU Out connector as it is.</td> <td>The data signal input to the Optical SMF Data In connector is output to the Recovered Clock Out connector as it is.</td> </tr> </tbody> </table>	Operation Mode	MP2110A-x54	MP2110A-x55	OFF	Clock is not output from the CRU Out connector.	Clock is not output from the Recovered Clock Out connector.	Recovery	The clock recovered from the data signal input to the CRU In connector is output to the CRU Out connector.	The clock recovered from the data signal input to the Optical SMF Data In connector is output to the Recovered Clock Out connector.	Through	The data signal input to the CRU In connector is output to the CRU Out connector as it is.	The data signal input to the Optical SMF Data In connector is output to the Recovered Clock Out connector as it is.
	Operation Mode	MP2110A-x54	MP2110A-x55											
	OFF	Clock is not output from the CRU Out connector.	Clock is not output from the Recovered Clock Out connector.											
	Recovery	The clock recovered from the data signal input to the CRU In connector is output to the CRU Out connector.	The clock recovered from the data signal input to the Optical SMF Data In connector is output to the Recovered Clock Out connector.											
Through	The data signal input to the CRU In connector is output to the CRU Out connector as it is.	The data signal input to the Optical SMF Data In connector is output to the Recovered Clock Out connector as it is.												

*5: This is displayed only when Sampling Mode is **Pulse**.

Table 6.2.6-1 Items of Time Dialog Box (Cont'd)

Tab	Item	Description		
CRU, CRU(26G), CRU(53G)	Clock Recovery	Sets the clock recovery unit when Operation Mode is Recovery . Displayed only when Operation Mode is Recovery .		
	Lock Status	Whether or not the clock recovery unit is locked on the input signal is indicated.		
			MP2110A-x54	MP2110A-x55
		Green	The clock output from CRU Out is locked on the input signal.	The clock output from Recovered Clock Out is locked on the input signal.
		Red	The clock output from CRU Out is NOT locked on the input signal.	The clock output from Recovered Clock Out is NOT locked on the input signal. No signal is input to Optical SMF Data In .
	Orange		The clock output from Recovered Clock Out is NOT locked on the input signal. A signal is input to Optical SMF Data In but is out of the symbol rate range.	
	Operation Rate	Selects the operating frequency of the clock recovery unit. Specifies the symbol rate (kbaud) if the Operation Rate is Variable .		
	CRU Loop BW	Selects the loop bandwidth of the clock recovery unit.		
CRU Lock	Allows the clock recovery unit to lock the recovered clock to the input signal.			
Auto Relock	Off: Does not perform CRU Lock automatically when a signal is input to the clock recovery unit. To lock to the input signal, click CRU Lock . On: Performs CRU Lock automatically when a signal is input to the clock recovery unit.			
Operation Clk Rate	MP2110A-x54: When Operation Mode is Through , the frequency of the clock input to the CRU In connector is displayed. MP2110A-x55: When Operation Mode is Through , the frequency of the clock input to the Optical SMF Data In connector is displayed.			

Depending on options, the settings are restricted as follows:

Scope Option

There are the following restrictions when MP2110A-x11, x12, or x14 is not installed.

- Tracking cannot be set to Symbol Rate: PPG at Data Clock Rate in the Time dialog box.
- Tracking cannot be set to On at Pattern Length in the Time dialog box.

6.3 Calibration and Adjustment

6.3.1 Calibrating Level

The amplitude accuracy of the sampling oscilloscope is guaranteed after performing calibration.

When the calibration is required, the error message “Calibration is required” is displayed in the Setup dialog box in red.

Perform the calibration, when using the MP2110A for the first time or the message is displayed.

The calibration procedures are as follows:

1. Check that no signals are input to the front-panel **Ch A In**, **Ch B In**, or **Trigger Clk In** connectors. If there are **Ch C** and **Ch D**, check that no signals are input to these connectors.
2. Click **Setup** to open the Setup dialog box.
3. Click the **Utilities** tab.
4. Click **Calibration**, and then the message is displayed to confirm that the signal is not input to the connector.

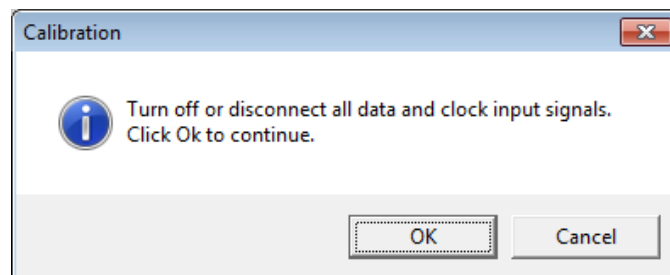

5. Click **OK**.

Upon completion of the calibration, a dialog box appears and gives you the calibration result.

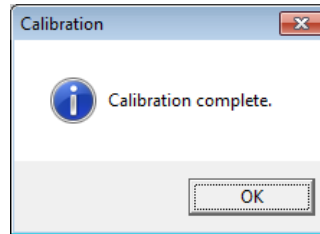

**Figure 6.3.1-1 Calibration Result Display
(When Calibration Is Successful)**

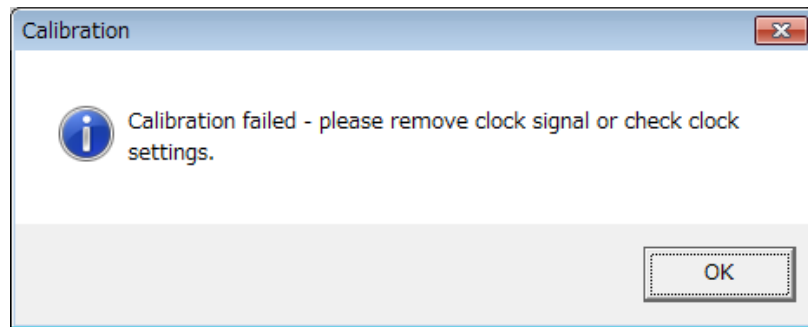

Figure 6.3.1-2 Calibration Result Display (When Calibration Fails)

If the calibration fails, follow the instruction that applies to your situation, and then retry from step 2.

- Check that the coaxial cable is not connected to any of the **Ch A In**, **Ch B In**, **Ch C**, **Ch D**, and **Trigger Clk In** connectors on the front panel.
- If it is required to keep the coaxial cables connected to the **Ch A In**, **Ch B In**, **Ch C**, **Ch D** and **Trigger Clk In** connectors on the front panel, check that the connectors do not receive any incoming signal.

6.3.2 Adjusting Dark Current

When light is not input to the Optical connector, the O/E module output voltage is adjusted.

The output voltage of the O/E module used changes depending on the ambient temperature.

Calibrate the MP2110A before using the optical connector.

1. Confirm that no light has been input to the optical connector (SMF or MMF).
2. Click **Amplitude**.
3. Click the **O/E** tab.
4. Click **Calibrate Module**.
5. The window confirming that the light is not input is displayed. Click **OK**.
6. In about 5 seconds from step 3, the dialog box appears indicating that the calibration is complete. Click **OK**.

6.3.3 Adjusting Values for Changing the Wavelength Bands

To measure an optical signal at the other wavelength band than 850 nm, 1310 nm or 1550 nm, adjust the values of Conversion Gain and Responsivity.

Warm up the O/E module at least one hour because the output voltage varies depending on the ambient temperature. Additionally, be sure to calibrate the sampling oscilloscope before performing adjustment.

<Adjusting Manually>

Adjustment method of Conversion Gain

1. Adjust the wavelength of the optical power meter to the optical signal.
2. Measure unmodulated optical signal power with the optical power meter.
3. Input the optical signal to the optical input connector.
4. Measure the average of the optical signal power by using the Histogram function of the sampling oscilloscope.
5. Click **Amplitude**.
6. Click the **O/E** tab.
7. Select **User** for the connector of the optical signal input at Input Connector (Wavelength).
8. Adjust the Conversion Gain value so that the average of the optical signal power measured by the Histogram function of the sampling oscilloscope becomes equal to the value measured by the power

meter. The System Conversion Gain value is automatically set by setting the Conversion Gain value.

Adjustment method of Responsivity

1. Adjust the wavelength of the optical power meter to the optical signal.
2. Measure unmodulated optical signal power with the optical power meter.
3. Input the optical signal to the optical input connector.
4. Measure the Average Power (mW) or Average Power (dBm) of the optical signal by using the Amplitude/Time function of the sampling oscilloscope.
5. Click **Amplitude**.
6. Click the **O/E** tab.
7. Select **User** for the connector of the optical signal input at Input Connector (Wavelength).
8. Adjust the Responsivity value so that the Average Power value of the optical signal measured by the Amplitude/Time function of the sampling oscilloscope becomes equal to the value measured by the optical power meter.

<Adjusting Automatically by Auto Correction>

1. Adjust the wavelength of the optical power meter to that of the optical signal.
2. Measure unmodulated optical signal power with the optical power meter.
3. Input the optical signal to the optical input connector.
4. Click **Amplitude**.
5. Click the **O/E** tab.
6. Select **User** for the connector of the optical signal input at Input Connector (Wavelength).
7. Set the Input Power to the value of the optical signal power measured by Step 2.
8. Click **Execute** to calibrate automatically.
9. When Auto Correction is completed, the values of Conversion Gain, and Responsivity are adjusted so that they become equal to the values measured by the optical power meter.

6.3.4 Performing Self Test

Perform the self test in the following cases:

- When the error message is displayed after level calibration referring to 6.3.1 “Calibrating Level”.
- When the noise voltage is over the specified value shown in Appendix A when the signal is not input
- When the waveform is not displayed, the displayed waveform amplitude and bit cycle is different from the expected value, and the MP2110A operation and measurement results are abnormal.

The application self test runs following items.

- Power

If the test result is normal, “passed” is displayed, on the other hand, if the test result is abnormal, “failed” is displayed.

The self test procedures are as follows.

1. Check that no signals are input to the front-panel **Ch A In**, **Ch B In**, **Trigger Clk In** connectors. If there are **Ch C** and **Ch D**, check that no signals are input to these connectors.
2. Click **Setup** to open the Setup dialog box.
3. Click the **Utilities** tab.
4. Click **Application Test**. The self test dialog box is displayed while the self test is running.
5. After the self test is completed, the result is displayed.

When the power supply test result is failed:

1. When the power voltage is displayed, record the value.
2. If the power supply test result shows “failed”, contact an Anritsu Service and Sales office.

6.4 Setting CRU

The clock recovery unit (CRU) generates a clock signal from the signal input to **CRU In** connector.

The waveform can be observed by using the generated clock signal.

The clock recovery unit sets the following.

- Operation Rate
- CRU Loop BW

Operation Rate sets frequency range.

CRU Loop BW is a loop filter bandwidth that is used in the frequency control circuit of the clock recovery unit.

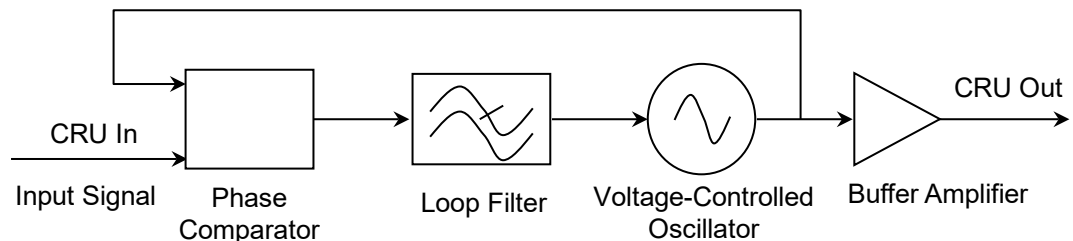

Figure 6.4-1 Block Diagram of Clock Recovery Unit

A wider frequency bandwidth can absorb more frequency fluctuations that occur momentarily. The loop filter bands for the Jitter measurement are defined in the communication standards.

CAUTION

- The impedance of the CRU In and CRU Out connectors is 50 Ω . If you use a coaxial cable with impedance other than 50 Ω , or connect a device with impedance other than 50 Ω , the measurement may not be performed properly.
- The CRU Out connector output voltage is 0.4 to 0.8 V_{p-p}. Make sure that the voltage output to the connectors does not exceed the input voltage range of a device to be connected. The voltage amplitude to be output to the CRU Out connector exceeds the input voltage range of a device to be connected, install an attenuator to the CRU Out connector.
- The amplitude of the signal input to the CRU In connector is 0.8 V_{p-p} max. This is equivalent to +2 dBm for a sine-wave signal. Inputting a signal with a larger voltage risks damaging the internal circuits.

Procedure

1. For MP2110A-x54

Connect the **CRU Out** and **Trigger Clk In** connectors with a supplied U-link coaxial cable (SMA).

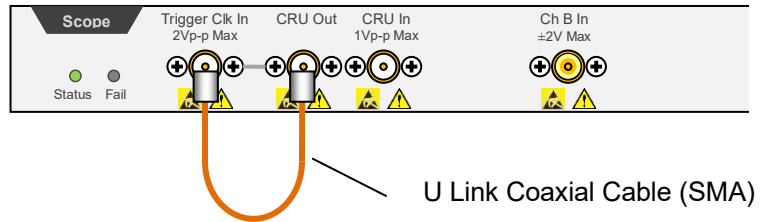

If the Scope module is equipped with **O/E Monitor Out** connector, Clock Recovery can be executed from Channel B optical signal input by connecting the **O/E Monitor Out** and **CRU In** connectors with a U-link coaxial cable (K). If the **O/E Monitor Out** and **CRU In** connectors are not connected, make sure to install a coaxial terminator to the **O/E Monitor Out** connector.

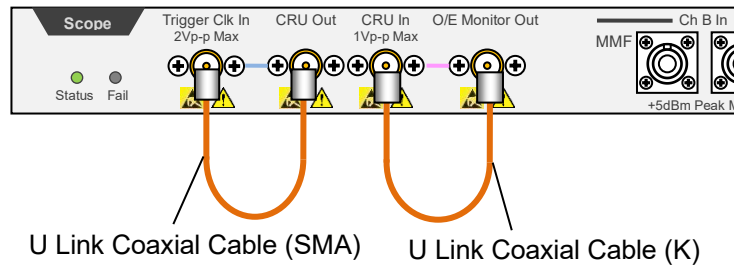

For MP2110A-x55

Connect the **Data Out** connector of 53G CRU and the **SMF In** connector of the scope, using a single-mode optical fiber.
Connect the **Recovered Clock Out** connector of 53G CRU and the **Trigger Clk In** connector of the scope, using a coaxial cable (SMA).

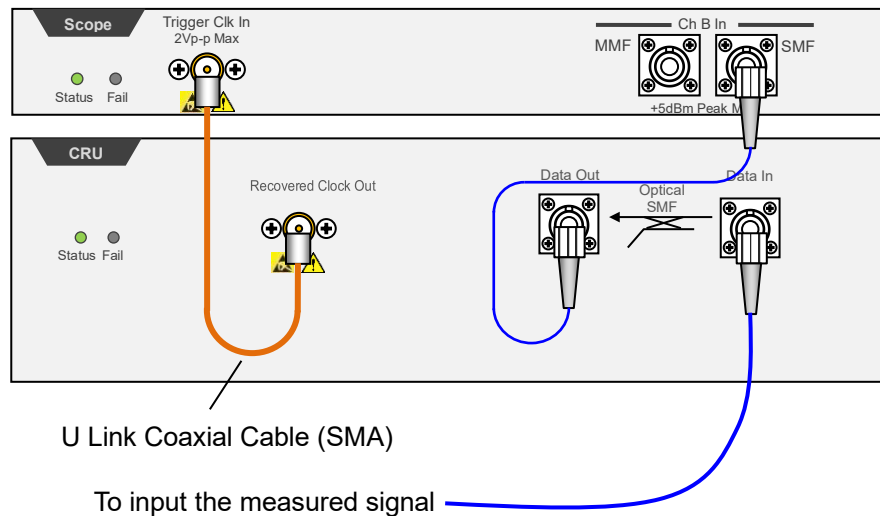

2. For MP2110A-x54
Input the signal to the **CRU In** connector.
For MP2110A-x55
Input the signal to the **Data In** connector.
3. Click **Time CRU**.
4. Click the **CRU** tab. When both MP2110A-x54 and MP2110A-x55 are installed, click the **CRU(26G)** or **CRU(53G)** tab.
5. Click the Operation Mode button and set the display to **Recovery**.
When locked on the signal input to the **CRU In** or **Data In** connector, the Lock Status indicator turns green.
If the Lock Status indicator is not on, “CRU Unlock” is displayed in the Result window.



MP2110A-x54



MP2110A-x55

6. Click the Operation Rate button and set the symbol rate.
7. Click the CRU Loop BW button and select the loop bandwidth from the following:
2 MHz, 4 MHz, 10 MHz, Bitrate/1667
8. Click **Rate** tab.
9. Click the Tracking button and set the display to **CRU**.

Notes:

- When the clock recovery unit is not used, set Operation Mode to **OFF** on the **CRU** tab.

- If the frequency of the input signal to the clock recovery unit is outside the frequency band set for Operation Rate, the clock recovery unit may not recover the clock. At that time, “CRU Unlocked” is displayed in the Result window.
- When the clock recovery unit is used, the symbol rate displayed at the bottom right in the waveform area may not be a desired value. At that time, check the signal waveform, frequency, and amplitude to input to the clock recovery unit. When the Lock Status indicator turns green and the CRU is locked on the input signal, click **Acquire Clock Rate** on the **Rate** tab.

6.5 Setting Rate

To collect data, the trigger clock synchronized with the input signal is required.

When BERT is installed in MP2110A, the synchronizing clock (Sync Out) can be used as the trigger clock.

When MP2110A-x54 Clock Recovery or MP2110A-x55 26G/53Gbaud Clock Recovery (SM Optical) is installed, the clock recovery unit can be set.

After the trigger clock is input to the MP2110A, set the symbol rate, clock rate, and divide ratio.

The symbol rate is the modulation rate of the signal to measure with Scope (**Ch A In** or **Ch B In**, or for quad channel, the signal input to **A, B, C** or **D**).

The clock rate is the frequency of the trigger clock.

Divide Ratio is the ratio between data symbol rate and clock rate.

The value should be inputted to complete the following formula.

$$\text{Symbol Rate} = \text{Clock Rate} \times \text{Divide Ratio}$$



CAUTION

- **The impedance of the Trigger Clk In connector is 50 Ω. Measurement may not be performed correctly if a cable with another impedance is used.**
- **The amplitude of the signal input to the Trigger Clk In connector is 2 Vp-p max. This is equivalent to + 10 dBm for a sine-wave signal. Inputting a signal with a larger voltage risks damaging the internal circuit**

6.5.1 Setting Symbol Rate

This section explains how to set the symbol rate of the signal to measure with Scope.

1. Click **Time**.
2. Click **Rate** tab.
3. Click the Tracking button of the Data Clock Rate to set to **Off**.
4. Click the Recalculate Option button to select **Clock Rate**.
5. Click the Divide Rate text box and input the division ratio.
6. Click the Symbol Rate text box and input the symbol rate.

The clock rate is calculated by the division rate and symbol rate.

Set the symbol rate and division rate so that the clock rate will be 15 000 000 kHz or less.

When BERT (MP2110A-x11, MP2110A-x12, or MP2110A-x14) is installed, the bit rate value of PPG can be set to the symbol rate of the sampling oscilloscope using the following procedure.

1. Click **Time**.
2. Click the **Rate** tab.
3. Click the Tracking button of the Data Clock Rate to select one of the following.

Symbol Rate: PPG, Divide Ratio: Clock Output

Symbol Rate: PPG, Divide Ratio: Sync Output

Symbol Rate: PPG, Divide Ratio: User Defined

When **Symbol Rate: PPG, Divide Ratio: User Defined** is selected, set Divide Ratio.

4. Connect the **Trigger Clk In** connector of Scope and a BERT connector.

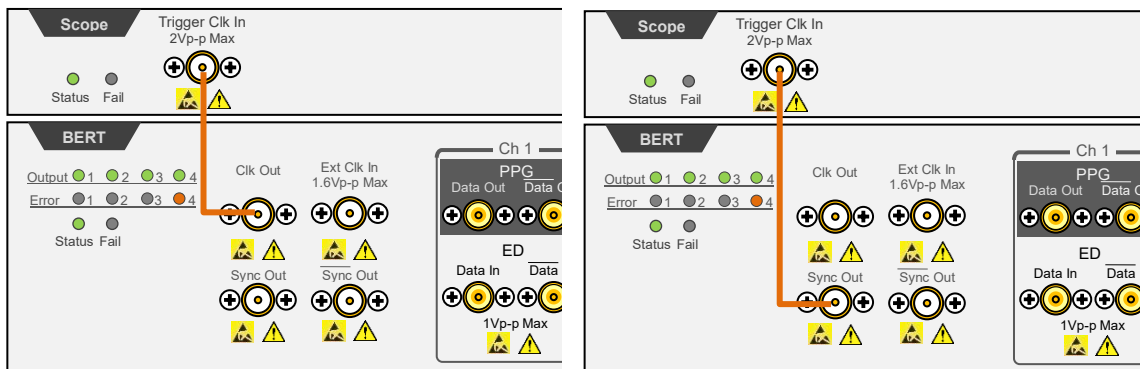

Bit Rate: PPG, Divide Ratio: Clock Output Is Selected Bit Rate: PPG, Divide Ratio: Sync Output Is Selected

When **Symbol Rate: PPG, Divide Ratio: User Defined** is selected, input clock with the divided frequency of **Clk Out**, **Data Out**, or **Data Out** signal from BERT to the **Trigger Clk In** connector of Scope.

6.5.2 Setting Clock Rate and Divide Ratio

The symbol rate can be set by measuring the clock rate from the signal input to the **Trigger Clk In** connector of the front panel.

1. Click **Time**.
2. Click the **Rate** tab.
3. Click the Tracking button of the Data Clock Rate to set to **Off**.
4. Click the Recalculate Option button to select **Symbol Rate**.
5. Click **Acquire Clock Rate**.

The frequency is displayed in the Clock Rate text box.

Confirm the waveform and signal level input to the **Trigger Clk In** connector when the frequency is not displayed.

6. When the clock frequency is not displayed at Clock Rate or the displayed frequency is not correct, click the Clock Rate text box and input the frequency.
7. Click the Divide Ratio text box and input the divide rate.
The symbol rate is calculated by the divide rate and clock rate.

When using the BERT Sync Out as an external clock, the divide ratio is set as follows.

Sync Output settings	Pattern	Divide Ratio
1/8 Clock	–	8
1/16 Clock	–	16
1/40 Clock	–	40
Pattern Sync	PRBS 2 ⁷ –1	127
	PRBS 2 ⁹ –1	511
	PRBS 2 ¹⁵ –1	32767
	PRBS 2 ²³ –1	8388607
	PRBS 2 ³¹ –1	214748647

When setting Sync Output to Pattern Sync, the data cannot be collected.

6.6 Setting Pattern Length

When the Pulse mode is set as described in Section 6.7 “Collecting Data”, the pattern length can be set.

In the Pulse mode, the pattern is synchronized by collecting data at the pattern length time cycle.

6.6.1 NRZ

1. Click **Time**.
2. Click **Scale/Offset** tab.
3. Click the Tracking button at Pattern Length, and then set to **Off**.
4. Click the Length text box at Pattern Length.
5. Input the pattern length by the symbol unit.

Note:

The settable pattern length is up to $32768 (2^{15})$.

When Test Pattern at PPG/ED is $2^{31}-1$, Tracking cannot be set to **On** at Pattern Length.

When Pattern Length Tracking is set to **On**, Test Pattern at PPG/ED cannot be set to $2^{31}-1$.

When changing the PPG/ED pattern length settings using the MP2110A, the changed setting values can be set to the sampling oscilloscope automatically.

1. Click **Time**.
2. Click the **Scale/Offset** tab.
3. Click the Tracking button at Pattern Length, and then set to **On**.

Note:

When Test Pattern of PPG/ED is set to **PRBS $2^{31}-1$** , Tracking of Pattern Length cannot be set to **On**.

4. Click the Master button at Pattern Length.
5. Select the PPG and ED with equal pattern lengths.

If Tracking is set to **Off**, Length can be set when Test Pattern is set to **Variable** on the **General** tab of the Setup dialog box.

Note:

If Test Pattern is set to **PRBS** or **SSPRQ** on the **General** tab, Length cannot be set. In this case, Tracking on the **Scale/Offset** tab is set to **Off**.

1. Click the text in the **Length** box at Pattern Length.

2. Enter the pattern length. PPG/ED's test patterns and their length are shown in the table below.

Table 6.6.1-1 Setting Length

Test Pattern	Pattern Length (symbols)
PRBS 2 ⁷ -1	127
PRBS 2 ⁹ -1	511
PRBS 2 ¹³ -1	8191
PRBS 2 ¹⁵ -1	32767
1/2 Clock Pattern	2
1/16 Clock Pattern	16

6.6.2 PAM4

1. Click **Setup**.
2. Click the Test Pattern button to select Pattern Length. When you select **Variable**, proceed to step 3.
3. Click **Time**.
4. Click **Scale/Offset** tab.
5. Click the text in the **Length** box at Pattern Length.
6. Enter the pattern length.

6.7 Collecting Data

The data collection method is composed of the following types.

Data synchronization method: Eye mode, Pulse mode, Coherent eye mode

Cumulative display for waveform: None, Infinite, Limited, Persistence, Average

Note:

In this document, measurement of one data item on the screen is described as “data capture” while obtaining one screen of data is described as “data collection”.

To switch to Eye/Pulse/Coherent Eye mode

1. Click **Setup**.
2. When MP2110A-x95 is installed, click the Signal Type button and select **NRZ** or **PAM4**.
3. In the Setup dialog box, click the Sampling Mode button to change it to **Eye**, **Pulse**, or **Coherent Eye**.

The Coherent Eye mode is used when calculating the waveform of Channel A and Channel B.

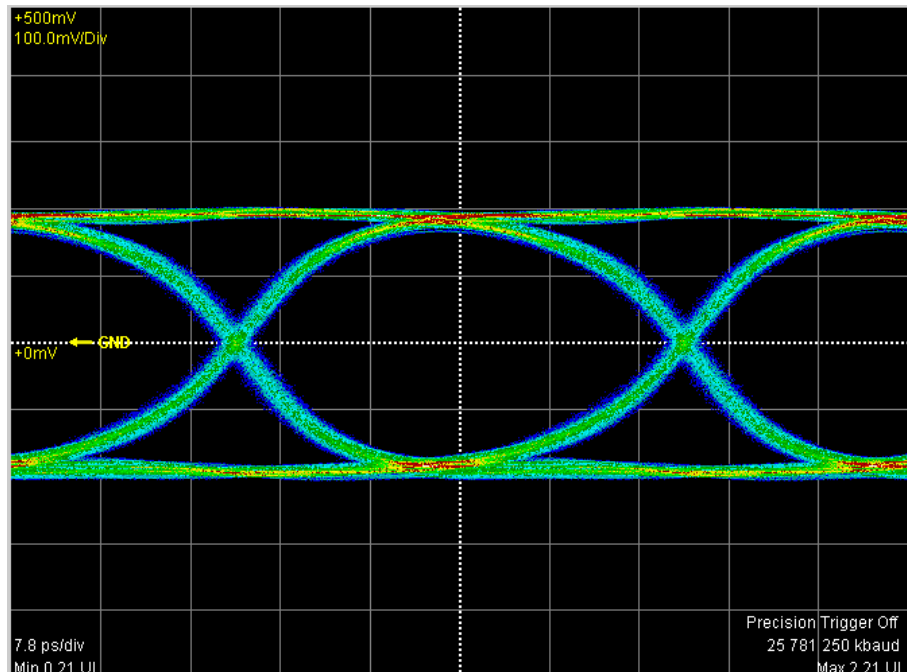

Figure 6.7-1 Eye Mode/Coherent Eye Mode Display Example

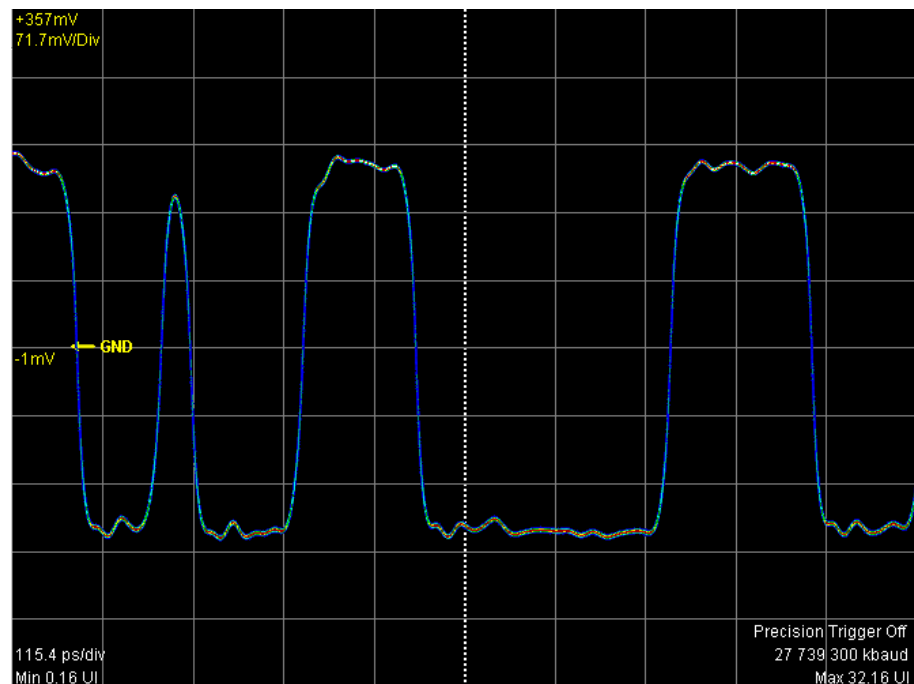

Figure 6.7-2 Pulse Mode Display Example

Setting overwritten waveform display

When setting the display method to **Infinite**, **Limited** or **Persistency**, the acquired data is overwritten on the screen.

1. Click **Setup** to open the Setup dialog box.
2. Select the single waveform data collection count from the following Number of Samples.

For **Eye**: 1350, 2048, 4050

For **Pulse, Coherent Eye**:

512, 1024, 2048, 4096, 8192, 16384

When Test Pattern is other than **Variable** in

Coherent Eye, Number of Samples is fixed to **16384**.

When there is only a small amount of captured data, the screen refresh time is short.

3. Click the Accumulation Type button, and set the items from the following lists:

Infinite: Unlimited time to overwrite waveform

Limited: The waveform is overwritten at the set time until it reaches the number of data or the numbers of waveforms. Data collection stops at the set time or when the data count is reached.

Persistency: Deletes overwritten data after fixed time elapsed.

4. When selecting **Limited** at step 3, set the at-end condition.
 - To end overwriting waveform when the set time is passed, set Limit Type to **Time**.
Click the Time text box to input the time.
 - To end overwriting waveform when the data count set at the screen is reached, set Limit Type to **Sample**.
Click the Samples text box to input the number of data.
 - To stop waveform overwriting when the set time has elapsed, set Limit Type to **Waveform**.
Click the Waveforms text box to input the number of waveforms.
5. When **Persistency** is selected at step 3, set the time for saving the overwritten data.
Click the Time text box to input the time.

Deleting overwritten waveform display

1. Click **Setup** to open the Setup dialog box.
2. Click the Accumulation Type button to select **None**.
3. Click the Number of samples button to select the number of data displayed on the screen from the following:

For **Eye**: **1350, 2048, 4050**

For **Pulse, Coherent Eye**:

512, 1024, 2048, 4096, 8192, 16384

When Test Pattern is other than **Variable** in

Coherent Eye, Number of Samples is fixed to **16384**.

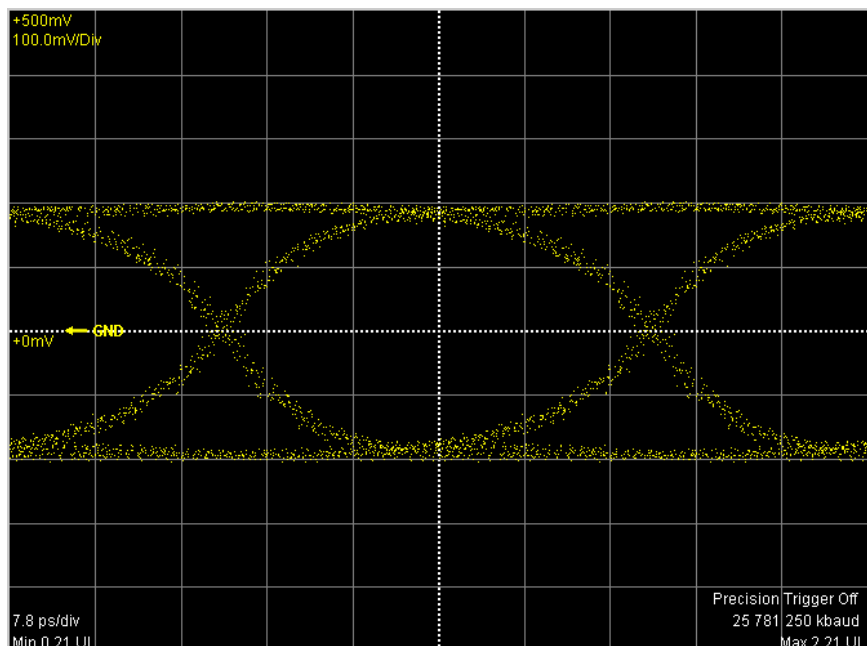

Figure 6.7-3 Accumulation Type Settings (None)

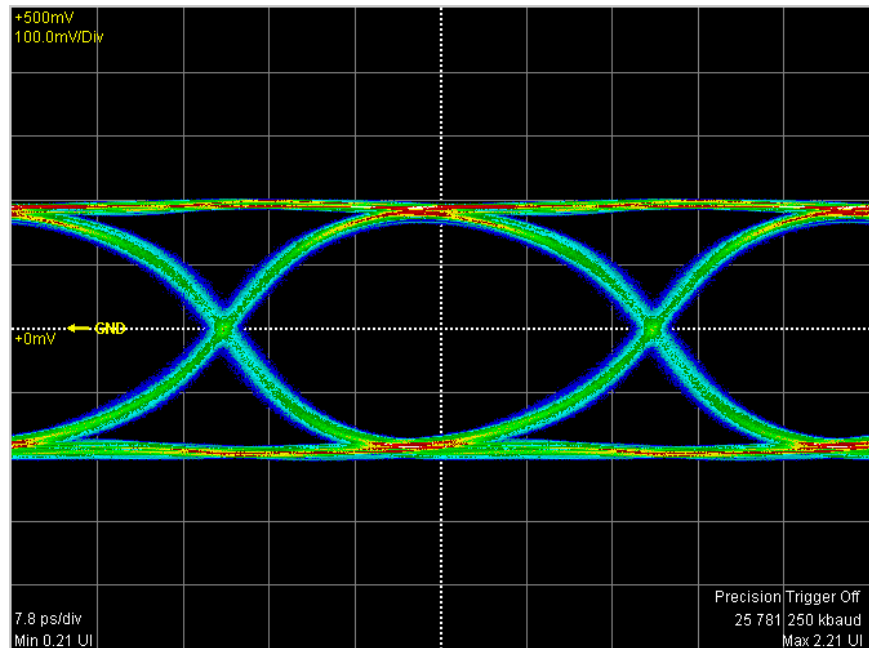

Figure 6.7-4 Accumulation Type Settings (Infinite)

Displaying averaging waveform

If Test Pattern is other than **Variable** in Pulse or Coherent Eye mode, When **Averaging** set to On, averaging is performed. Averaging process is used to suppress waveform noise.

Note:

When **Averaging** is set to On, the precision trigger is disabled even when **Precision Trigger** is set to On.

1. Click **Setup** to open the Setup dialog box.
2. Set **Averaging** to On.
3. In Pulse mode, click the Number of Samples button to select the number of data displayed on the screen.
In Coherent Eye mode, set Test Pattern according to the pattern of the input signal.
4. In the **Waveforms** or **Pattern** box, set the number of waveforms to be averaged.

In averaging, the average value of the number of data points set in the Waveforms or Pattern box is calculated and is displayed on the screen. However, when 1 is input, no averaging is performed. The number of averaging waveforms is displayed on the screen while executing averaging.

The waveform is captured a hundred times when the following condition is set, and a hundred averaging waveforms are displayed.

- Averaging On
- Waveforms 100 wfms

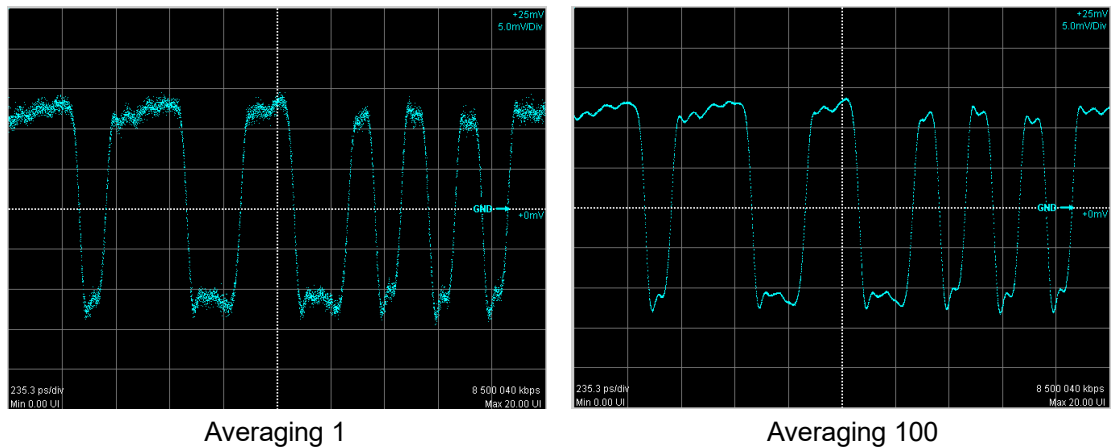

Figure 6.7-5 Example of Averaging Process

The averaging is calculated using the following formula.

Number of waveforms \leq Averaging setting count:

$$Ave(n) = \frac{(n - 1) \times Ave(n - 1) + S(n)}{n}$$

Averaging setting count \leq Number of waveforms:

$$Ave(n) = \frac{(M - 1) \times Ave(n - 1) + S(n)}{M}$$

- Ave(n): Averaging value
- S(n): Measurement value
- M: Averaging setting count
- n: Number of waveforms

The size of the noise is inversely proportional to the square root of the averaging setting count.

For example, if M is set to 100, the noise amplitude is compressed to about 1/10 compared to when M is set to 1.

Once the data collection is started, the waveform is displayed on the screen.

Starting data collection

1. Display the waveform of the channel with the monitor signal input.
When the Trace Switch Buttons are displayed in gray, reset the gray display by clicking them.
2. To collect multiple channel data, click the Control Ch button to toggle to **All**. When **Single** is displayed on the Control Ch button, data on only the active channel is collected.
3. Click the **Sampling** button to display **Sampling Run** at the button display.

The elapsed time, number of samples and number of waveforms are displayed in the title bar when **Accumulation Type** is set to **Limited**.

Samples: 163,840 - 10 / 100wfms

The data collection can also be started by the **All Measurements Start** button shown in Figure 4.1-1.

Stopping data collection

Click the **Sampling** button, and then set to **Sampling Hold**. When, in the Setup dialog box, Accumulation Type is set to **Limited**, the data collection process stops when the at-end conditions are met.

The data collection can be started by clicking all measurement stop button as shown in Figure 4.1-1.

Discarding screen display

- When temporarily deleting screen display:
Click the Trace switch buttons to bring the color into gray.
By clicking a gray Trace switch buttons, its trace is displayed.
- When discarding collected data:
Click **Clear Display**.
Trace data will be discarded even if the Trace switch buttons are gray and no traces are displayed on the graph.
The discarded data cannot be displayed again.

6.8 Adjusting Scales

6.8.1 Adjusting Scales Automatically

Measure the waveform amplitude and period, and then set to the easily viewable scale.

For Eye /Coherent Eye Mode

1. With the trace switch buttons, select the channel you want to display in the center of the waveform display area. In this example, click **Ch A**.
2. Click **Auto Scale**. The waveform is displayed at the center of the waveform display area.

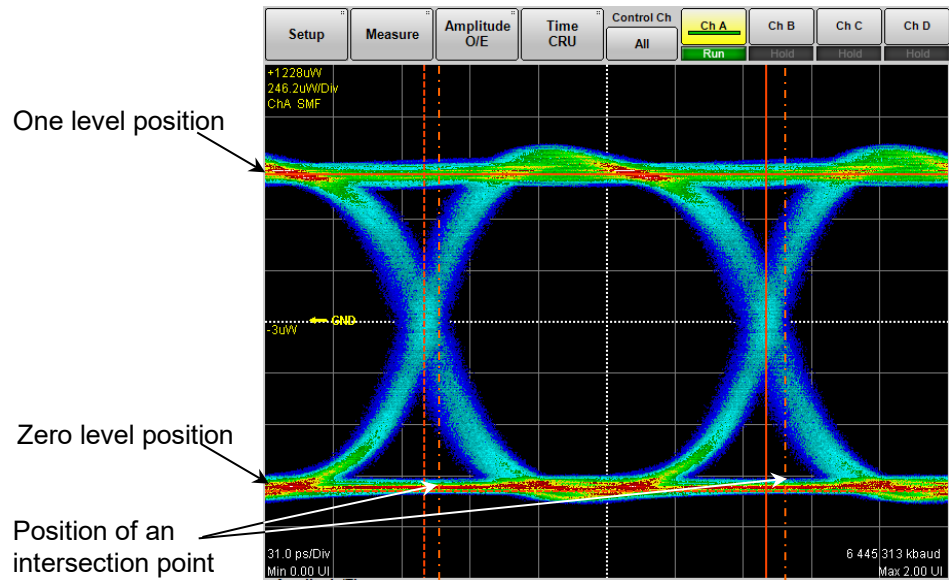

Figure 6.8.1-1 Waveform Display after Auto Scale (Eye/Coherent Eye Mode)

When adjusting scale automatically, the two-bit waveform is displayed on the horizontal axis.

The Eye pattern waveform crossing points are 2.5 and 7.5 scale divisions from the left side.

At the vertical axis, “one” level 2.5 gridlines above center of grid, “zero” level 2.5 gridlines below center of grid.

Note:

If more than one channel display is ON, the action depends on the Control Ch setting.

- When Control Ch is **Single**

The time axis offset and the amplitude axis scale and offset are adjusted to the active channel signal.

- When Control Ch is **All**

The time axis offset is adjusted to the active channel signal.

The Software Delay settings for channels other than the active channel are also adjusted so that the waveforms are displayed in the center.

The amplitude axis scale and offset are adjusted to all channel signals.

In addition to the scale adjustment of waveform display area, Auto Scale automatically detects the division rate of the data rate of input signal and the trigger signal. Set **Divide Ratio Detect** to **Off** to not detect the division rate automatically. When **Tracking of Data Rate and Clock Rate** is set to **On**, the division rate of the data rate and the trigger signal is not detected.

When MP2110A-x95 is installed, **Auto Scale + Calculate + Sampling** is displayed. When clicked, **Calculate** for Auto Scale and Reference Equalizer are performed, and then **Sampling** is set to **Run**. When Accumulation Type is **Limited** and Limit Type is **Pattern**, the data for only the set pattern is collected and the result is displayed. When Channel Math is **On**, **Auto Scale + Calculate + Sampling** is not available.

For Pulse Mode

1. Click **Auto Scale**.
2. The waveform is displayed at the screen center.

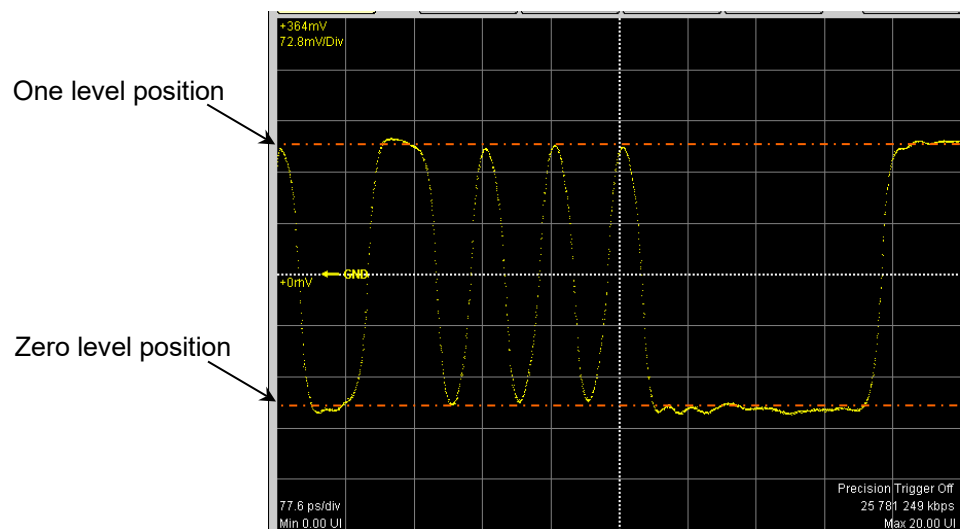

Figure 6.8.1-2 Waveform Display after Auto Scale (Pulse Mode, NRZ)

When the pattern length is 127 bits or less, a 20-bit waveform is displayed.

When the pattern length is 128 bits or more, a 50-bit waveform is displayed.

The One level is adjusted on the vertical scale to the 2.5th scale up from the screen center and the Zero level is adjusted to the 2.5th scale down from the screen center.

6.8.2 Adjusting Vertical Axis

To adjust voltage or optical power at center of vertical axis

1. Click **Quick Menu** on the left side of the waveform display area.
2. When the buttons are displayed, click the **Offset** button of Amplitude. The mouse icon is displayed in the button.

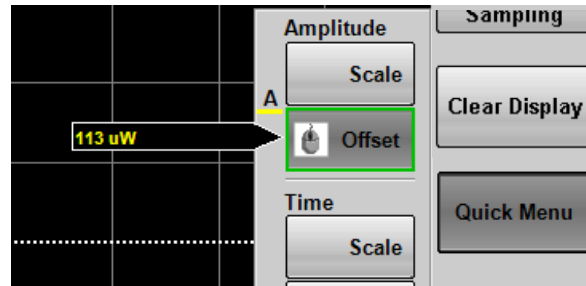

3. Input the power voltage or optical power at the screen center position using the mouse wheel.

To adjust voltage or optical power per scale:

1. Click **Quick Menu** in the right side of the waveform display area.
2. When the buttons are displayed, click the **Scale** button. The mouse icon is displayed in the button.
3. Input the voltage or optical power per scale using the mouse wheel. This causes a change of the scale value of the active channel displayed in the waveform display area. For the location of scale display, refer to Figure 6.2.1-6.

The vertical-axis can also be adjusted by directly entering the value in the Amplitude O/E Dialog Box.

1. Click **Amplitude O/E**.
2. Click the Offset text box.
3. Input the voltage or optical power at the screen center position.
4. Click the Scale text box.
5. Input the voltage or optical power per scale.

Setting same vertical scale for multiple waveforms

The vertical scales at all channels can be set to the equal value using the MP2110A-x21, MP2110A-x22, MP2110A-x30, MP2110A-x32, MP2110A-x39, MP2110A-x40, MP2110A-x42, and MP2110A-x49.

1. Click **Amplitude**.
2. Click the Tracking button, and set to **On**.
3. Click the Scale, Offset, and Attenuation text boxes, and then set the values.

Note:

When Tracking is set to **On**, the Scale, Offset, and Attenuation values of other channels are also changed to the set values.

When **Scale** and **Offset** for Amplitude are set on the Quick Menu at the right of the waveform display area, the scales and offsets of other channels are also changed.

Adjusting attenuation of attenuator

When an attenuator is attached to the signal input connector of Scope, the vertical axis scale can be corrected by the attenuation amount.

1. Click **Amplitude**.
2. Select a channel by clicking the channel button.
3. Click the Attenuation text box.
4. Input the attenuation.

The n dB attenuation is calculated by the following formula:

$$\text{Electrical input: } 10^{\frac{n}{20}}$$

$$\text{Optical input: } 10^{\frac{n}{10}}$$

6.8.3 Adjusting Horizontal Axis

Adjusting time at left edge of waveform display area

1. Click **Quick Menu** in the right side of the waveform display area.
2. When the buttons are displayed, click the **Offset** or **Delay** button of Time. The rotary knob icon is displayed in the button.

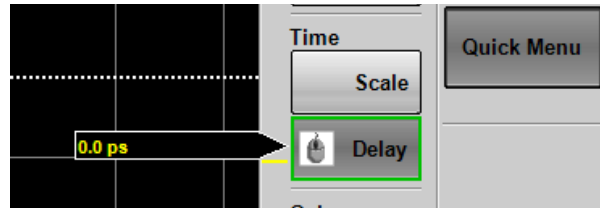

3. Input the time at left edge of screen using the mouse wheel.
4. The time entered is displayed at the left lower corner of the waveform display.

When set to **Offset**, to switch the horizontal position units between UI (unit interval) and time (ps), click **Time** and the Unit button.

Adjusting the number of bits to display

Result window

1. Click **Quick Menu** in the right side of the waveform display area.
2. When the buttons are displayed, click the **Scale** button of Time. The mouse icon is displayed in the button.
3. Input the number of bits per scale using the mouse wheel.
4. The sum of the value at the bottom left of the screen and the input value is displayed at the bottom right.

Time dialog box

1. Click **Time**.
2. Click the **Scale/Offset** tab.
3. Click UI on Screen text box.
4. Input the number of bits.

6.9 Measuring Waveform

The waveform measurement methods are as follows. For the explanation of the measurement items, refer to 1.5 “Technical Terms”.

- Amplitude and time measurements

Select the measurement items from the following:

For NRZ

One Level, Zero Level, Eye Amplitude, Eye Height, Eye Height (Ratio), Crossing, SNR, Average Power (dBm), Average Power (mW), Extinction Ratio, Jitter P-P, Jitter RMS, Rise Time, Fall Time, Eye Width, DCD, OMA/VMA, OMA (dBm), OMA/VMA at Crossing, VECP, TDEC, RIN OMA*, Crossing Time, Amplitude P-P

The Average Power (dBm), Average Power (mW), Extinction Ratio, OMA (dBm), and RIN OMA can be measured when the input is optical.

When the MP2110A-x95 is installed, the RIN OMA can be measured.

For PAM4

TDECQ*, Outer OMA(dBm), Outer OMA/VMA, Outer ExR, Linearity, Ceq, Partial TDECQ*, Levels, Levels RMS, Levels P-P, Level Skews, Eye Levels, Eye Skews, Eye Heights, Eye Widths, Transition Time (Rise/Fall)*, Transition Time (Slow)*, Over/Under-shoot, P-P Power*, Power Excursion, Noise Margin, Partial Noise Margin

When Average Power (dBm), Average Power (mW), and RIN OMA, Amplitude P-P are added as NRZ measurement items, they are measured as well in PAM4 mode.

Outer OMA(dBm), Outer ExR, Average Power (dBm), Average Power (mW), P-P Power, Power Excursion, and RIN OMA can be measured when the input is optical.

*: Indicates the item that can be measured when Sampling Mode is **Coherent Eye** and Test Pattern is other than **Variable**.

- Jitter analysis

For Eye

TJ, DJ (d-d), RJ (d-d), J2 Jitter, J4 Jitter, J9 Jitter, Eye Opening

For Advanced Jitter

TJ, DJ (d-d), RJ (d-d), J2 Jitter, J4 Jitter, J9 Jitter, Eye Opening, DDPWS, RJ (rms), PJ (p-p), DDJ (p-p), DCD, ISI (p-p), PJ Frequency

- Mask test
For NRZ, sets the mask pattern and mask margin, and then measures the data count in the mask.
The set data count can measure the mask margin within the mask.

Table 6.9-1 Measurement Method per Displayed Mode

Sampling Mode Measurement Method	Eye	Pulse	Coherent Eye	Advanced Jitter
Amplitude and time measurements	✓	*	✓	✓
Jitter analysis	✓	–	–	✓
Mask test	✓	✓	✓	–

*: Only the following items can be measured.

For NRZ:

Average Power (dBm), Average Power (mW)

For PAM4:

Average Power (dBm), Average Power (mW), Linearity, Levels

6.9.1 Setting and Displaying Measurement Items

Waveform amplitude and time can be measured when data is collected by Eye mode or Coherent Eye mode.

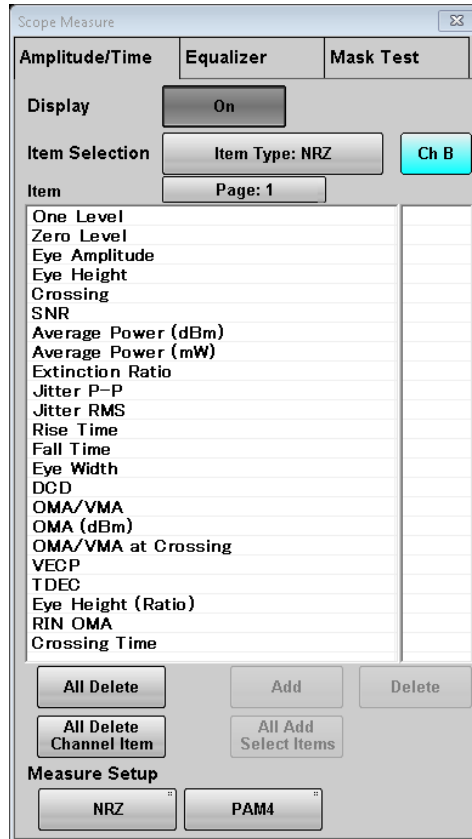

Figure 6.9.1-1 Amplitude/Time Tab When Signal Type is NRZ

To set measurement items:

1. Click **Measure** to open the Measure dialog box.
2. Click **Amplitude/Time** tab.
3. Click on the right column of an item or items you want to add. The column of the selected item turns into light blue.
4. Click **Add**, and the light blue column is selected by ✓. Click **All Add Select Items**, and the selected items are added to all channels.
5. Click the **Off** button of Display to turn it **On**. Make sure all the selected items are displayed in the Result window.
6. Click the Measure Setup button.
7. The item selected for the Item Selection list is added.
8. The measurement result is displayed in the button of the screen.

If the added item is the same as an item selected already for the same channel, that item cannot be added using Item Selection.

To display measurement area

Set the range to measure One level and Zero level of the NRZ waveform respectively.

1. Click the **Setup (NRZ Amplitude Time)** at Measure Setup. The **Setup (NRZ Amplitude Time)** dialog box appears.
2. Click **Offset from Crossing** and **Width** of EYE Boundary and set the values respectively. Refer to “Figure 6.9.1.1-2 Setting Item of EYE Boundary”.

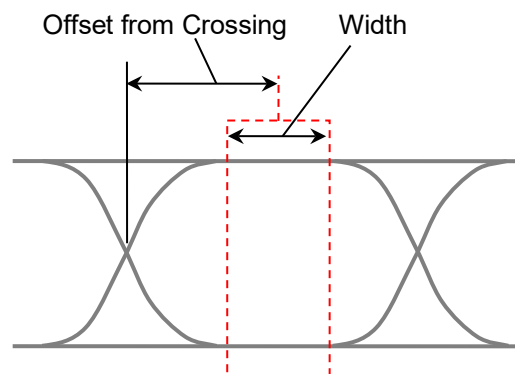

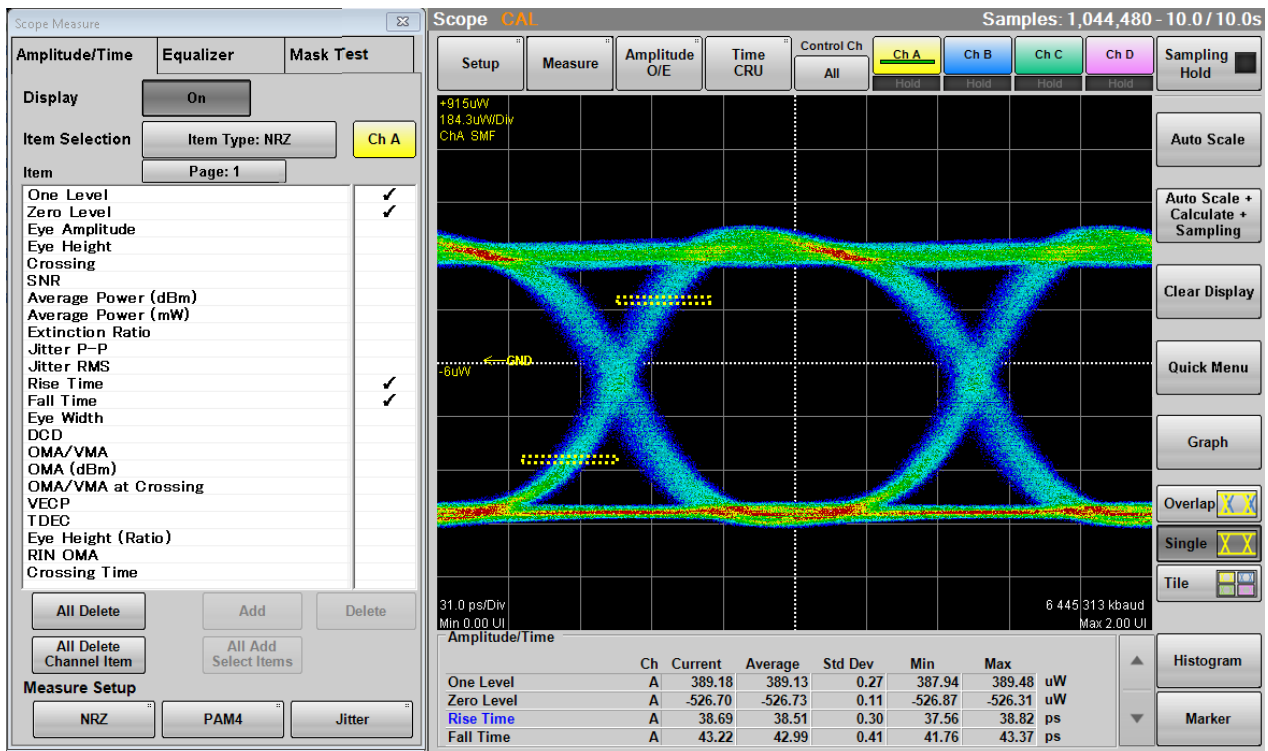

Figure 6.9.1-2 Display Example of Measurement Area

If the item is measured properly in PAM4 waveform, PAM4 in black is displayed. When there is a possibility the waveform may not have been measured correctly due to too small amplitude or too large jitter, channel name and “NRZ?” in red is indicated as shown below. When the PAM4 waveform is measured, PAM4? is displayed. In this case, check the settings for the amplitude and trigger of the measured signal and make sure the connectors are secure.

Amplitude/Time	Ch	Current	
CHA NRZ?			*1:Corrected
One Level	A	N/A	uW
Zero Level	A	N/A	uW
Rise Time	A	N/A	ps
Fall Time	A	N/A	ps

Figure 6.9.1-3 Appearance of Amplitude/Time Area (When Measurement Results May Be Incorrect)

When Extinction Ratio Correction is set to **On** on the Amplitude O/E Dialog Box in Section 6.2.5, “*1” is displayed in red beside the corrected measurement item.

When PAM4 waveform is measured in Coherent Eye, the lock marks are displayed beside the Outer OMA (dBm), Outer OMA/VMA, Outer ExR,

Overshoot, and Undershoot results if the Sampling Oscilloscope is locked on the pattern (Pattern Lock).



Amplitude/Time		
CHB PAM4		Ch
TDECQ		B
Outer OMA		B
Outer ExR		B
Linearity		B

Figure 6.9.1-4 Example of PAM4 Display

Deleting items

1. Click **Measure**. The Measure dialog box appears. The Measure dialog box is displayed.
2. Click **Amplitude/Time** tab.
3. Click ✓ in the right column of the item(s) you want to delete.
4. Click **Delete**. The Results window items are removed.

To delete all the items selected for the active channel, click **All Delete Channel Item**.

To delete the items selected for all channels, click **All Delete**.

6.9.1.1 NRZ

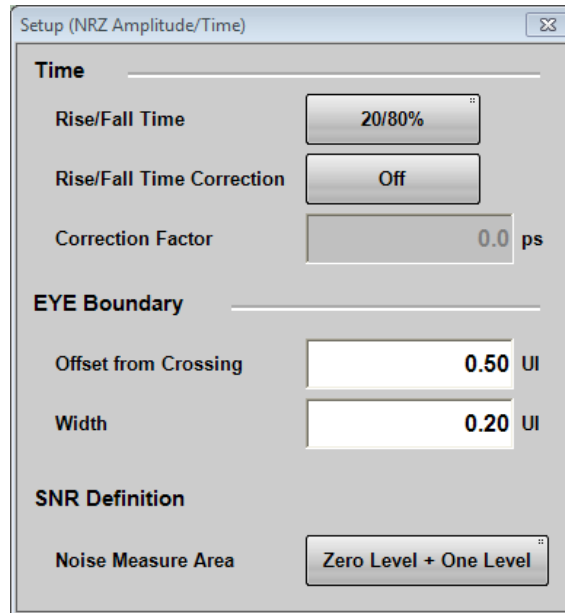

Figure 6.9.1.1-1 Setup (NRZ Amplitude/Time) Dialog Box

To change EYE Boundary

The 1 and 0 level measurement area can be changed.

1. Click **NRZ** at Measure Setup on Figure 6.9.1-1.
2. Click the Offset from Crossing text box to set the area center position.
3. Click the Width text box to set the area width.

To set measurement method of rise/fall time

When measuring the rise time and fall time levels, select from amplitude 10/90% level or 20/80% level.

- Click the Rise/Fall Time button to display 10/90% or 20/80%.

The bandwidth of the sampling oscilloscope is corrected with the measurement value of the Rise/Fall time, and the corrected bandwidth is displayed.

1. Click **NRZ** at Measure Setup.
2. Click **Rise/Fall Time Correction** to set the button display to **On**.
3. Click the Correction Factor text box.
4. Input the correction value in ps.

The calculation formula is as follows:

$$Td = \sqrt{Tm^2 - Tc^2}$$

Td: display value (ps), Tm: measurement value (ps),

Tc: correction value (ps)

If the measurement value is larger than the correction value, the result displays N/A.

“*1” is displayed in red at the Rise/Fall time when Rise/Fall Time Correction is set to **On**. When Rise/Fall Time Correction is **On**, “*1” is displayed in red at Rise Time and Fall Time. “*1:Corrected” is displayed in the measurement result display area and indicates that the values with “*1” have been corrected. The number is subject to change from 1.

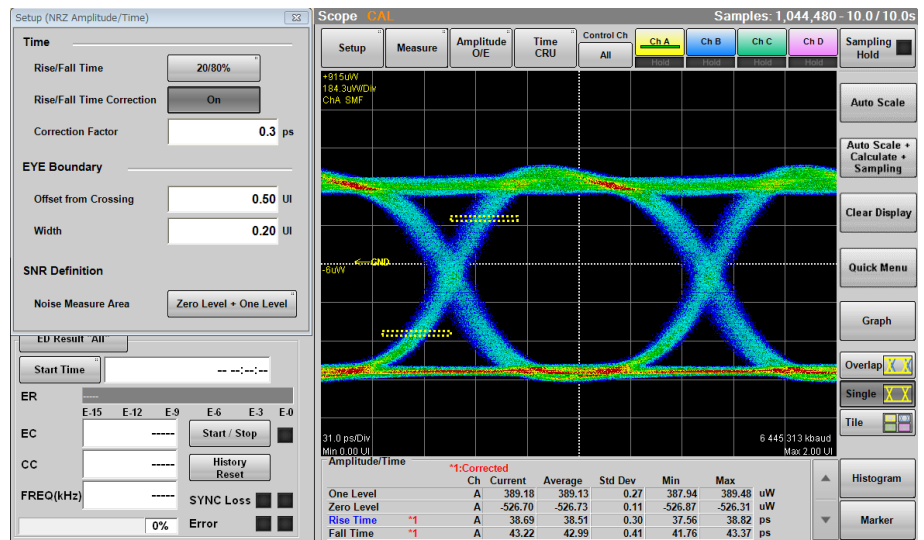

Figure 6.9.1.1-3 Display Example of Measurement Results

6.9.1.2 How to Measure TDECQ

This section explains how to measure TDECQ.

You can use a tool that simplifies this procedure and is available at:

C:\Users\Public\Documents\Anritsu\MX21000A\UserData\Demo\TDECQ_Assistant

1. Click **Setup**.

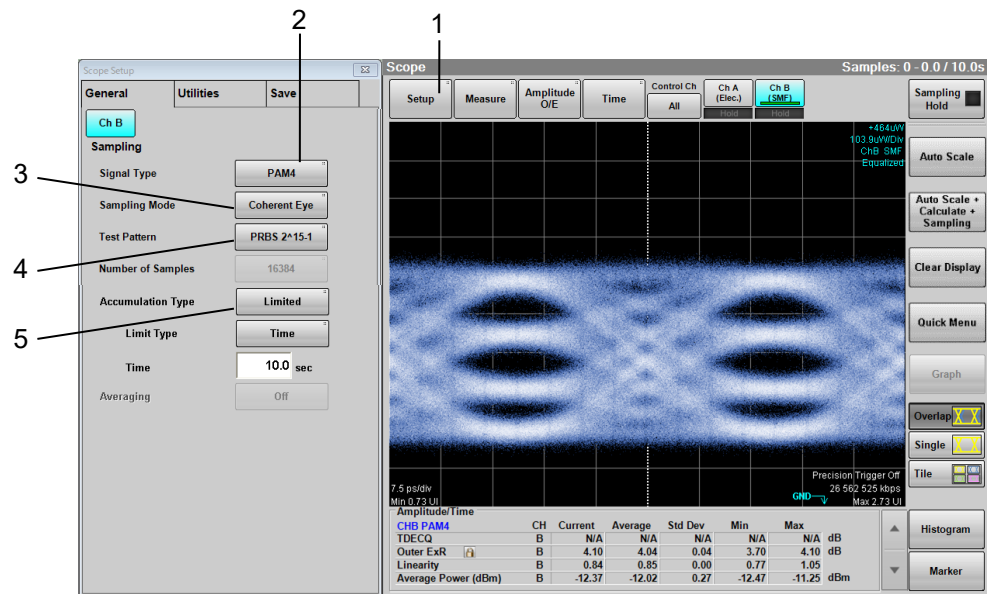

Figure 6.9.1.2-1 General Tab Settings

2. Set measurement channel's Signal Type to **PAM4**.
3. Set Sampling Mode to **Coherent Eye**.
4. Set Test Pattern to one of the following:
 - PRBS2^7-1:** 127 symbols
 - PRBS2^9-1:** 511 symbols
 - PRBS2^11-1:** 2047 symbols
 - PRBS2^13-1:** 8191 symbols
 - PRBS2^15-1:** 32767 symbols
 - SSPRQ:** 65535 symbols

Variable cannot be selected for TDECQ measurement.
5. Set Accumulation Type when needed.

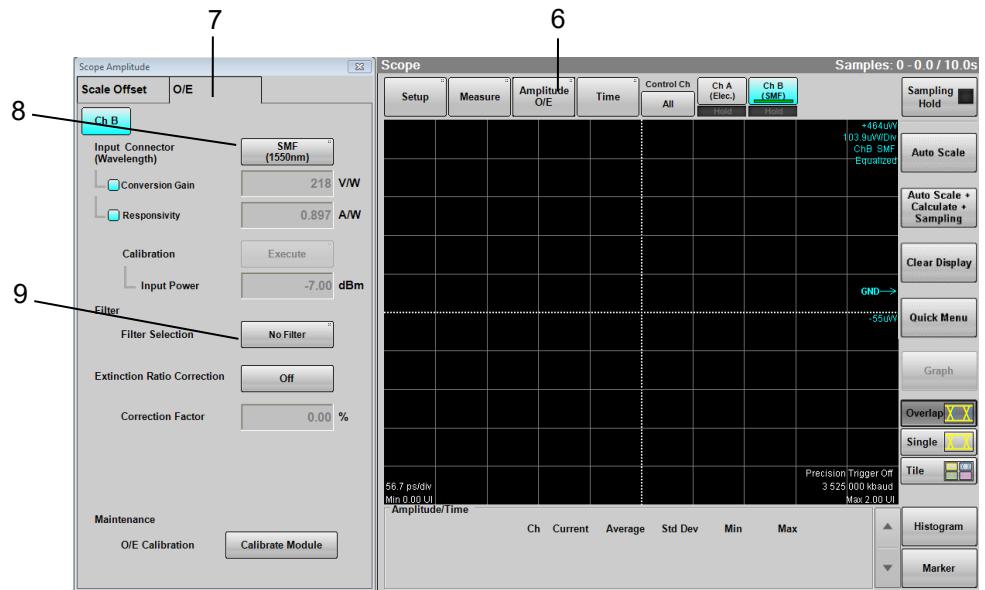

Figure 6.9.1.2-2 O/E Tab Settings

6. Click **Amplitude O/E**.
7. Click **O/E** tab.
8. Set **Input Connector (Wavelength)** when needed.
9. Select a filter at Filter Selection. To measure TDECQ specified in the IEEE standard, select:
 - **13.28125 GHz 26 Gbaud TDECQ** for TDECQ of 26 Gbaud SMF
 - **26.5625 GHz 53 Gbaud SM TDECQ** for TDECQ of 53 Gbaud SMF
 Digital filters are available when Sampling Mode is set to **Coherent Eye** and Test Pattern is set to other than **Variable**.

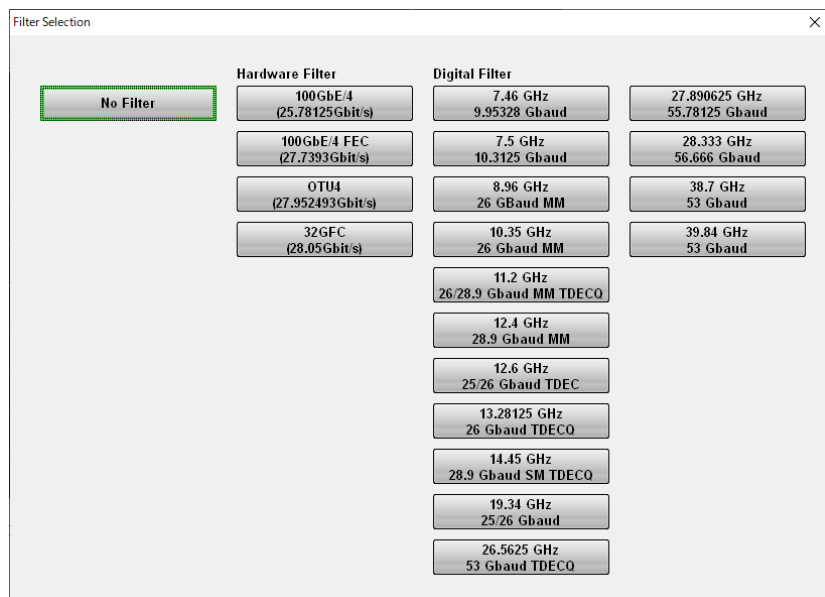

Figure 6.9.1.2-3 Filter Selection Dialog Box

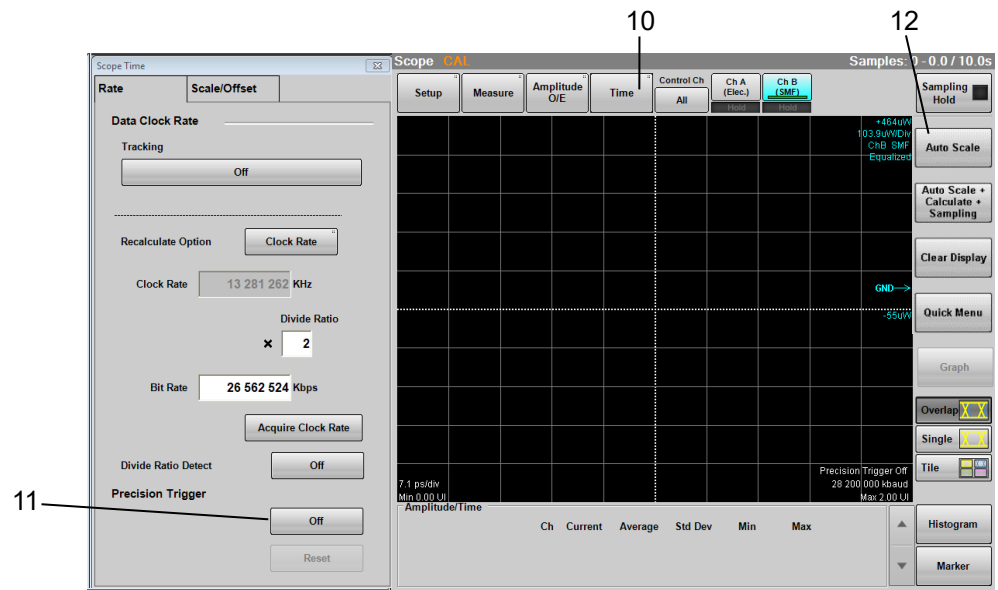

Figure 6.9.1.2-4 Rate Tab Settings

10. Click **Time**.
11. Set **Precision Trigger** when needed.
12. Click **Auto Scale**.

If the scales are not set properly, set the value for Divide Ratio, and then click **Acquire Clock Rate**. In Coherent Eye or Pulse mode, only the following values can be set for Divide Ratio:

1/2, 1/4, 1/8, 1/16, 1/32, 1/40, 1/48, or 1/64

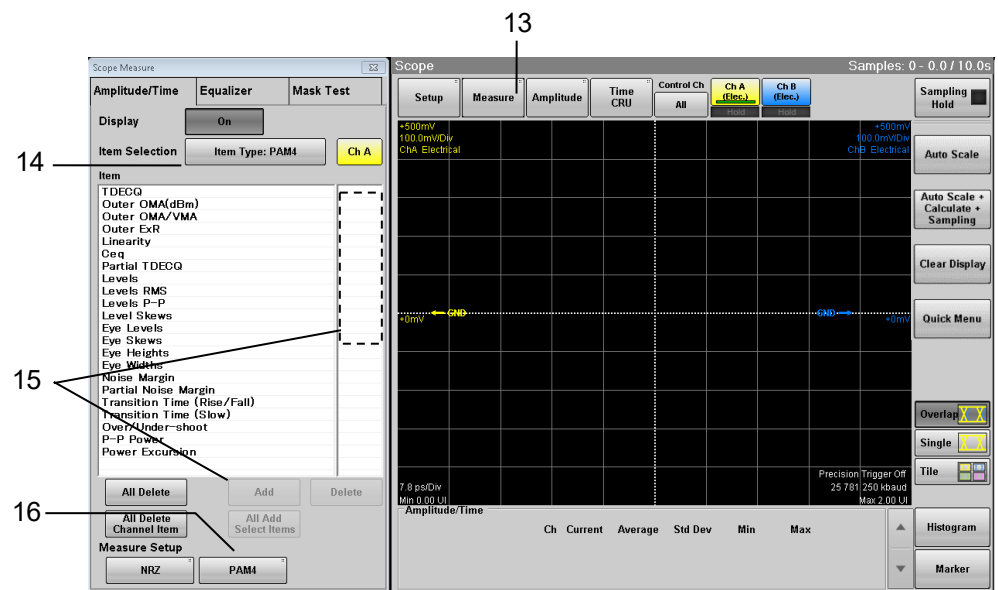

Figure 6.9.1.2-5 Amplitude/Time Tab Settings

13. Click **Measure**.

14. Set Item Selection to **Item Type: PAM4**.
15. Click and select the measurement item(s), and then click **Add**.
16. Click **PAM4** at **Measure Setup** to display **Setup (PAM4 Amplitude/Time)** dialog box.

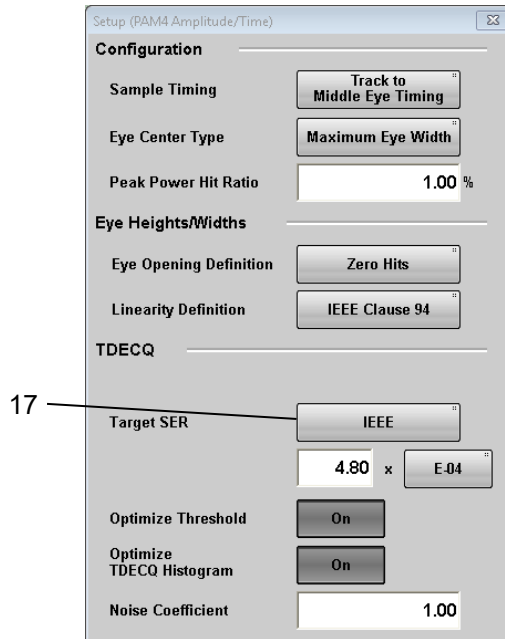

Figure 6.9.1.2-6 Setup (PAM4 Amplitude/Time) Dialog Box

17. Set **Target SER**.

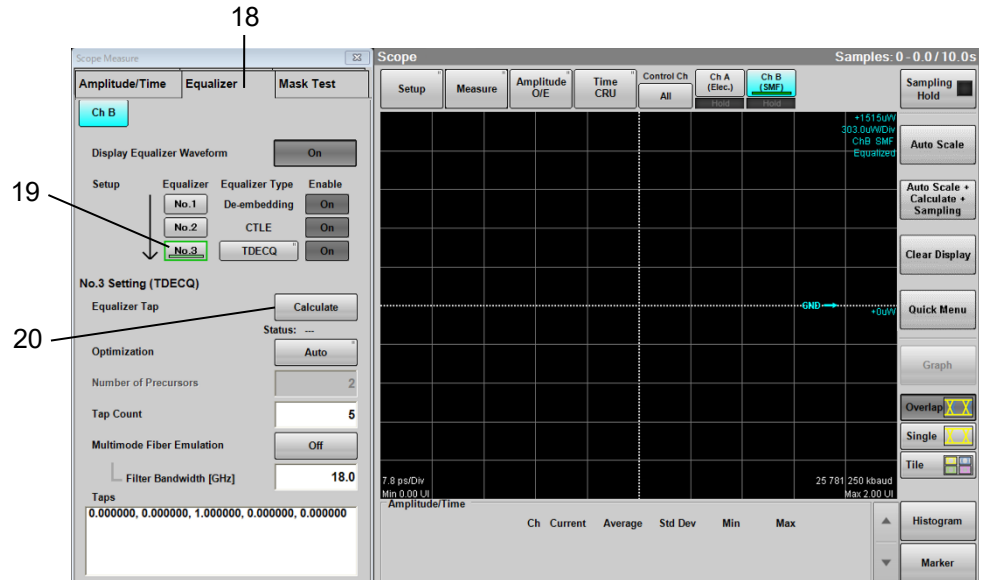

Figure 6.9.1.2-7 Equalizer Tab Settings

18. Click **Equalizer** tab.

19. Click **No.3**.

20. Click **Calculate** to set Tap values automatically
Set Tap Count and Optimization as needed.

21. Click **Sampling**, and you will see that **Sampling** is followed by **Run**.
Set Target SER and Optimize Threshold as needed.

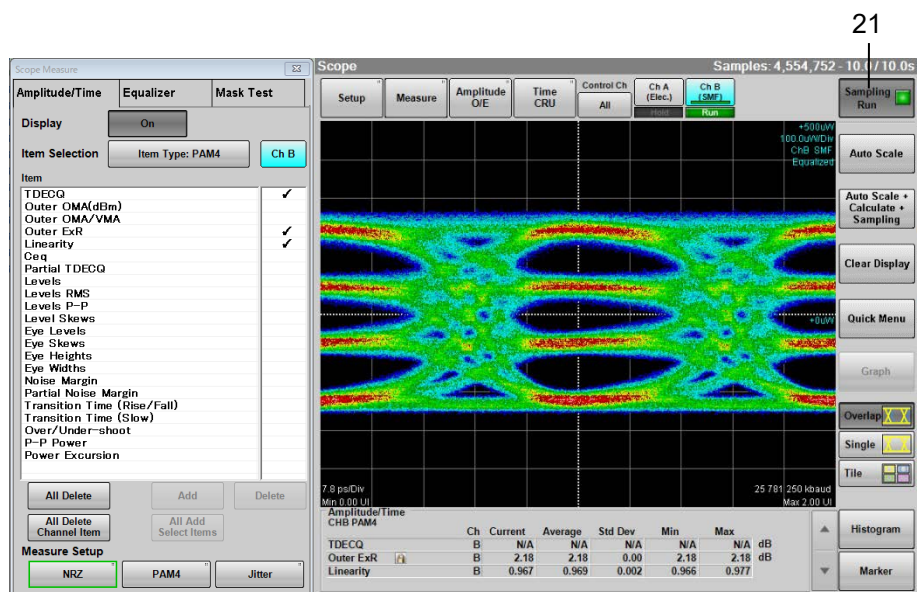

Figure 6.9.1.2-8 Display Example of Measurement Results

22. To display the not-equalized waveform, set Display Equalized Waveform shown in Figure 6.9.1.2-7 to **Off**.

To change the waveform color, on the **Utilities** tab shown in Figure 6.9.1.2-1, set Waveform Color to **Gray Scale**, and then click **Color Select**.

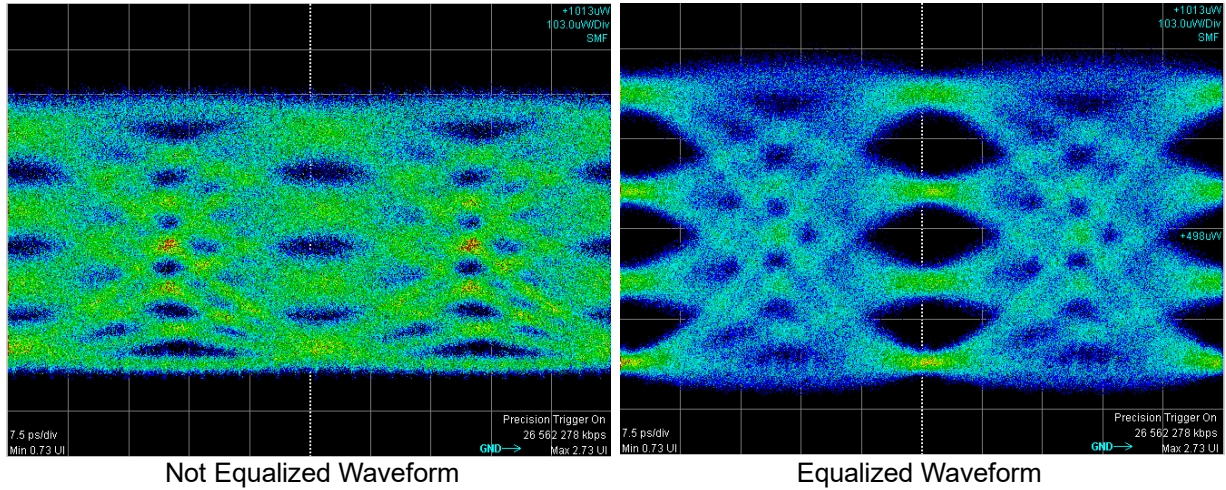

Figure 6.9.1.2-9 Example of TDECQ Improvement by Reference Equalizer

6.9.2 Mask Test

To execute the mask test, first select measurement channel and mask. There are two types of mask tests as follows:

- Set the upper data error count and measure the mask margin.
- Set the mask margin and measure the error data count.

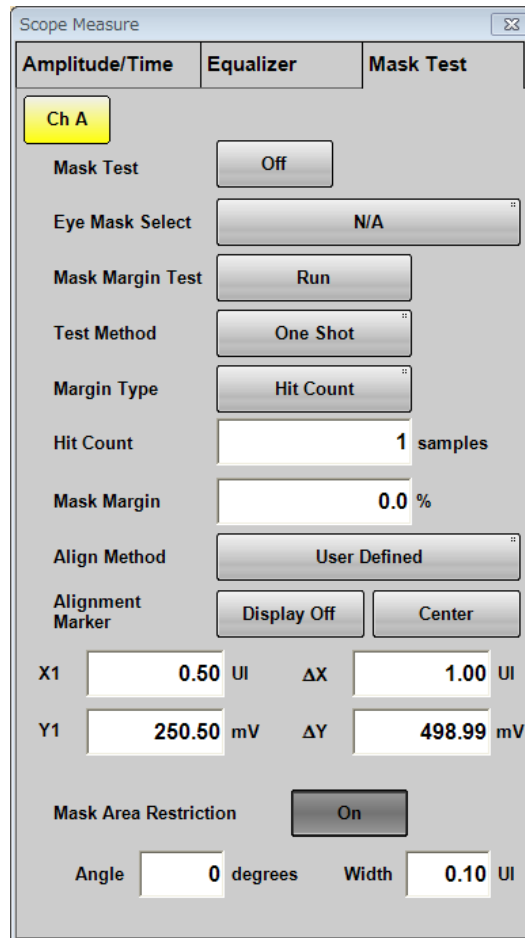

Figure 6.9.2-1 Setting Example of Mask Test

To select channel and mask

1. Click **Measure** to open the Measure dialog box.
2. Click **Mask Test** tab.
3. Click Active channel switch button, and then select the channel to be measured. Mask test cannot be performed in the following cases:
 - Signal Type of the channel is set to **PAM4**.
 - Sampling Mode is set to **Advanced Jitter**.
 - Sampling Mode is **Coherent Eye** and Test Pattern is set to other than **Variable**.
4. Click the Eye Mask Select button to select the mask.
5. The **Eye Mask Select** dialog box is opened. Click the mask file and **OK**.

The selected mask or mask file is displayed in the **Current Mask** box of the measurement results. Refer to Figure 6.9.2-2 “Mask Test Example”.

Table 6.9.2-1 Mask List

Mask Name	Standard	Bit Rate
100GbE-ER4_Tx.txt	100GbE-ER4	25.78125 Gbit/s
100GbE-LR4_Tx.txt	100GbE-LR4	25.78125 Gbit/s
100GbE-SR4_Rx.txt	100GbE-SR4	25.78125 Gbit/s
100GbE-SR4_Tx.txt	100GbE-SR4	25.78125 Gbit/s
100GbE-SR10_Tx.txt	100GbE-SR10	10.3125 Gbit/s
100GbE-CLR4-FEC.txt	100GbE-CLR4 FEC	25.78125 Gbit/s
100GbE-CLR4.txt	100GbE-CLR4	25.78125 Gbit/s
100GbE-CWDM4.txt	100GbE-CWDM4	25.78125 Gbit/s
100GbE-CWDM4_Rx.txt	100GbE-CWDM4	25.78125 Gbit/s
40GbE-SR4_Tx.txt	40GbE-SR4	10.3125 Gbit/s
25GbE-LR_ER_Tx.txt	25GbE-LR 25GbE-ER	25.78125 Gbit/s
CAUI-10_XLAUI_Tx.txt	CAUI-10/XLAUI	10.3125 Gbit/s
nPPI_module_to_host.txt	nPPI (XLPPPI/CPPI)	10.3125 Gbit/s
OTU-4.txt	OTU-4	27.952493 Gbit/s
32GFC_MM.txt	32GFC	28.05 Gbit/s
32GFC_SM.txt	32GFC	28.05 Gbit/s
8GFC_Elect_Rx.txt	8GFC	8.5 Gbit/s
8GFC_Elect_Tx.txt	8GFC	8.5 Gbit/s
InfiniBand_EDR_Cable_In_Limiting.txt	InfiniBand EDR	25.78125 Gbit/s
InfiniBand_EDR_Cable_Out_Limiting.txt	InfiniBand EDR	25.78125 Gbit/s
InfiniBand_EDR_Host_Out_Limiting.txt	InfiniBand EDR	25.78125 Gbit/s
InfiniBand_EDR_Stressed_In_Limiting.txt	InfiniBand EDR	25.78125 Gbit/s
HDMI_TP1.txt*1	HDMI	*3
HDMI_TP2.txt*2	HDMI	*3

*1: Mask file for HDMI transmitter

*2: Mask file for HDMI receiver

*3: Bit rate is unspecified.

To measure mask margin

1. Click **Setup**.
2. Click the Sampling Mode button to set the display **Eye** or **Coherent Eye**.
3. Click **Sampling** to set the display Run.
4. When the trace is displayed, click **Auto Scale**.
Check that the eye pattern is displayed in the center of the screen.
5. Click **Measure**.
6. Click **Mask Test** tab.
7. Click the Channel button to set the channel.
8. Click the Eye Mask Select button.
9. The file selection screen is displayed. Click a mask file and **OK**.
10. Click the Align Method button to set to **Zero/One/Crossing**.
11. Click the Margin Type button, and then select a mode of specifying threshold for Mask Margin measurement, from **Hit Count** and **Hit Ratio***.
12. In the Hit Count or Hit Ratio box, set the threshold for Mask Margin measurement.
13. Click the Mask Test button and set the display to **On**.
14. When performing the single measurement, click the Test Method button and set to **One Shot**.
When performing the measurement continuously, click the Test Method button and set to **Continuous**.
15. Click **Update**.
16. When selecting **One Shot**, click **Run** of Mask Margin Test to set Sampling to Hold and measure Mask Margin. On the other hand, when selecting **Continuous**, set Sampling to Run to measure Mask Margin.

Whichever of **One Shot** and **Continuous** is selected, the mask margin is measured so that the number of samples in the mask area becomes less than the value set for Hit Count or Hit Ratio.

*: The relational expression of Hit Count and Hit Ratio is:

$$\text{Hit Count} = \frac{\text{Hit Ratio} \times \text{Total Samples}}{\text{Bit On Screen}}$$

To set Mask Margin and execute mask test

1. Click **Setup**.
2. Click the Sampling Mode button to set the display **Eye** or **Coherent Eye**.
3. Click **Sampling** to set the display Run.
4. When the trace is displayed, click **Auto Scale**.
Check that the eye pattern is displayed in the center of the screen.
5. Click **Measure**.
6. Click **Mask Test** tab.
7. Click the Channel button to set the channel.
8. Click the Eye Mask Select button to select the mask.
9. Click the Align Method button to set to **Zero/One/Crossing**.
10. Click the Mask Test button and set the display to **On**.
11. Click the Test Method button to set to **One Shot**.
12. Click **Sampling** to set the display to Hold.
13. Click **Update**.
14. Click the mask margin text box.
15. Input the mask margin in the range of -100 to 100% .
16. The shape of the mask is changed, and the measurement result is displayed on the screen.

Note:

When executing the Mask Test, run Auto Scale to set UI On Screen to 2.

The Mask Test measured value is assured when UI On Screen is 2. If UI On Screen is 3 or more, the optimum Mask position may not be detected because the vertical scale setting is not optimum.

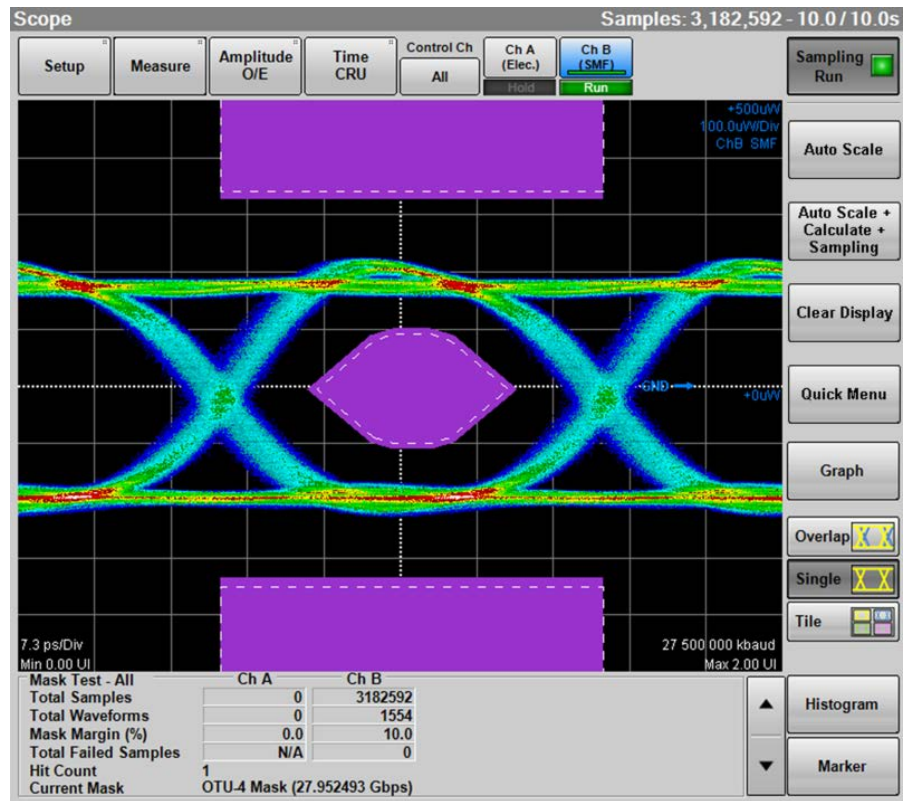

Figure 6.9.2-2 Mask Test Example

The following values are displayed in the measurement result:

- Total Samples: Total data count displayed on the screen
- Total Waveforms: Total waveform count displayed on the screen
- Mask Margin: Mask Margin measurement results or settings
- Hit Count or Hit Ratio: Threshold set for Mask Margin measurement
- Total Failed Samples: Total data count within three mask areas
- Top Mask Failed Samples: Data count in top mask area
- Center Mask Failed Samples: Data count in center mask area
- Bottom Mask Failed Samples: Data count in bottom mask area
- Current Mask: Present mask name

Adjusting mask position

To adjust mask position automatically

When Align Method is **Zero/One/Crossing**, click the Mask Alignment **Update**.

When clicking the Mask Alignment **Update** calculate **Zero/One/Crossing** of the currently described waveform and optimize the mask position automatically.

The mask position is adjusted automatically if the Scale and Offset on the screen are changed. However, the mask position cannot be changed.

To adjust mask position manually

When Align Method is **User Defined**, the mask position, width and amplitude can be adjusted using the marker.

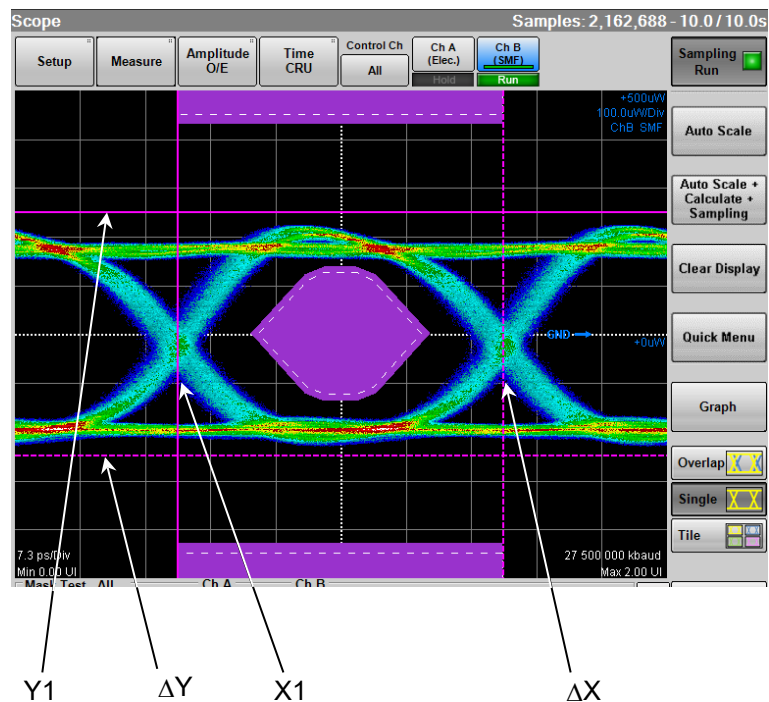

Figure 6.9.2-3 Example of Adjusting Mask Position Manually

1. Click the right side button of Alignment Marker and set **Display On** to display the marker.
2. Click the X1 text box to set the mask position.
3. Click the ΔX text box to set the mask width.
4. Click the Y1 text box to set the level 1.
5. Click the ΔY text box to set the level 0.

Clicking **Center** moves the marker without depending on the waveforms. In this case, the setting values of X1, ΔX , Y1, and ΔY are initialized. Although the marker is not displayed at **Display Off**, the marker position can be adjusted by changing the value in the text box.

To limit mask area

To examine in which part of the mask at the center the error occurs when the error occurs in the mask test, the mask area can be limited.

Setting width and angle can limit the mask area.

If the mask area is limited, the error that occurs in an upper and lower mask area is not measured.

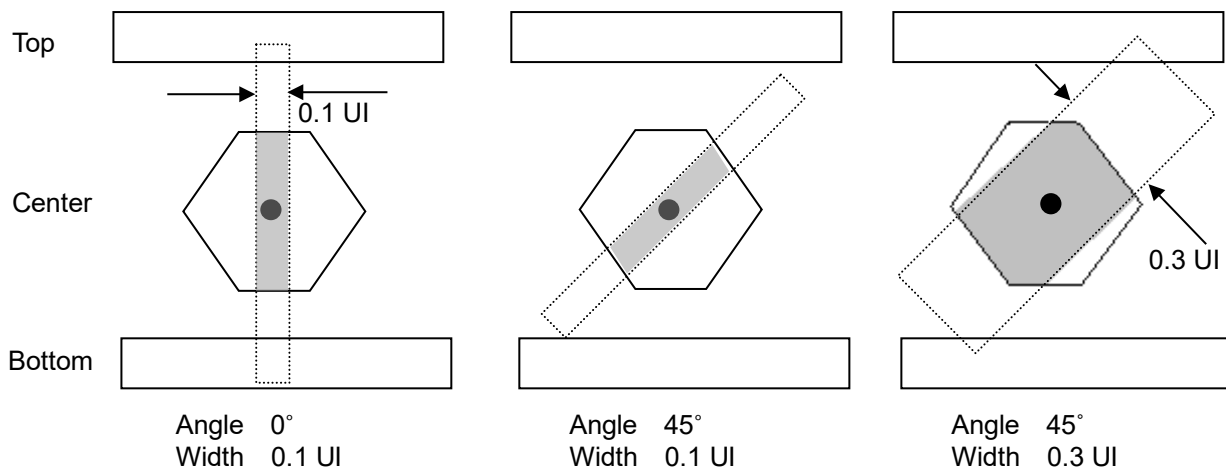

Figure 6.9.2-4 Example of Limiting Mask Area

1. Click **Measure**.
2. Click **Mask Test** tab
3. Click the Target Channel button to set the channel.
4. Click the Mask Area Restriction button to set **On**.
5. Click the **Angle** text box to set the angle within the range of -90 to 90.
6. Click the **Width** text box to set the width within the range of 0.01 to 1.00.

“Restriction enabled” is displayed in the measurement result display area.

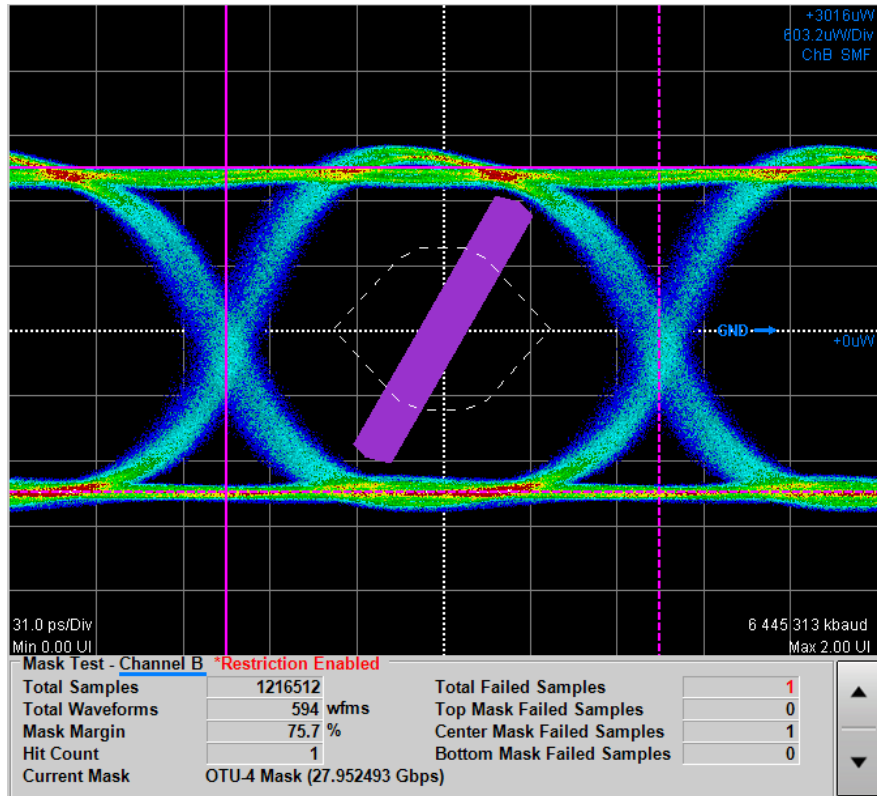

Figure 6.9.2-5 Example of Area Limited Mask Test

6.9.3 Jitter Analysis

The jitter analysis displays the measurement results of the following items by jitter element.

- Numeric value (ps, UI Unit)
- Histogram
- Spectrum
- Pattern display per bit

Jitter can be analyzed when Sampling Mode of Scope is set to **Eye** or **Advanced Jitter**.

Sampling Mode is Eye

Analyzes the jitter measured from histogram in the time direction of Eye pattern waveform. Jitter that can be measured from the Eye pattern waveform is only TJ.

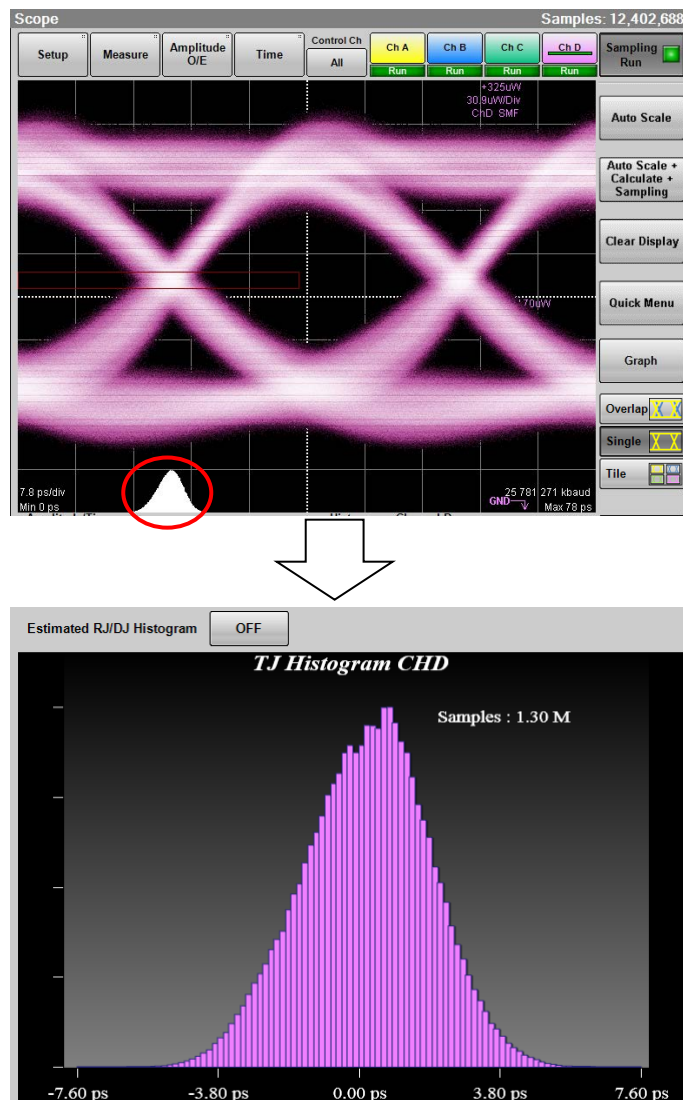

Figure 6.9.3-1 Example of Histogram Display

Jitter analysis can measure different kinds of jitter at the same time. Also, Eye Mask can be measured simultaneously.

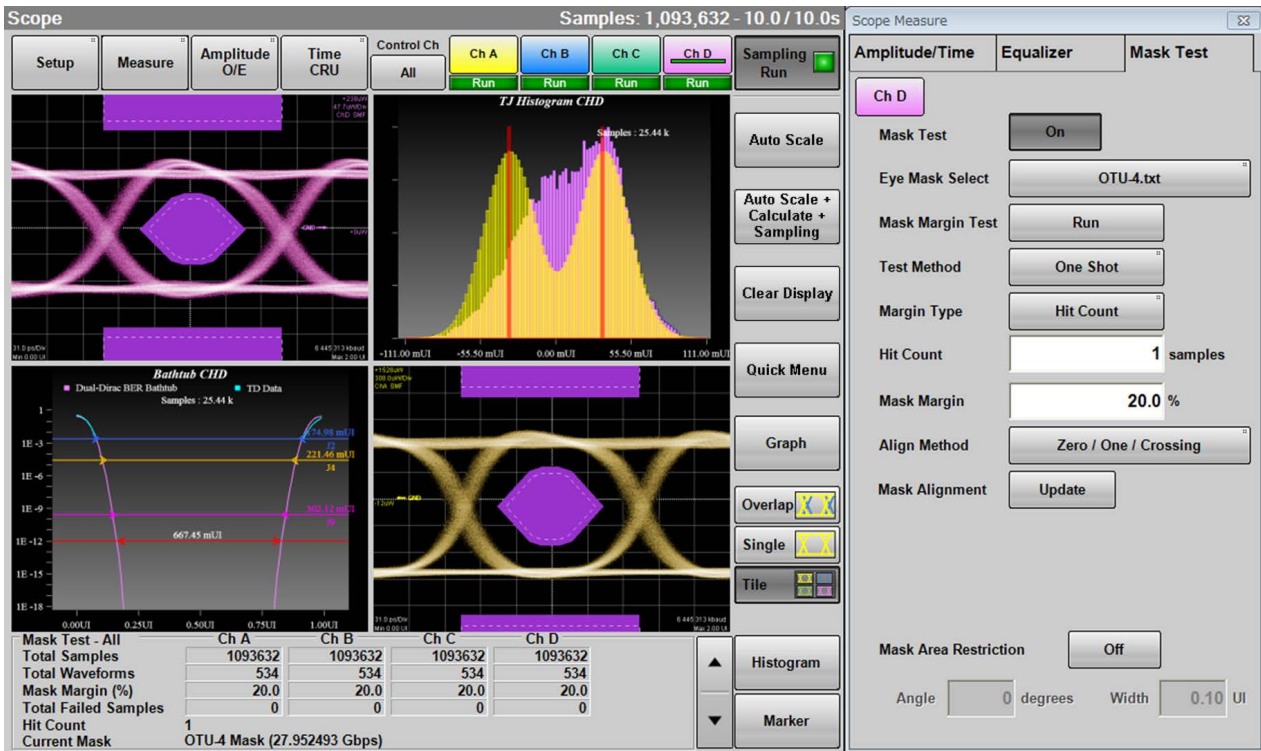

Figure 6.9.3-2 Display Example of Jitter Analysis and Eye Mask Test

When Channel Math of Scope is **Off**, jitter can be analyzed without any limit of pattern length.

When Channel Math of Scope is **On**, the jitter analysis can be performed on the waveforms of pattern length up to 32768.

When Extinction Ratio Correction is set to **On** on the Amplitude O/E Dialog Box in Section 6.2.5, “*1” is displayed in red beside the corrected measurement item.

When **Fixed RJ** is set to **On** on the **Advanced** tab of the **Jitter Measure** dialog box (Figure 6.2.4-8), “*2” is displayed in red for RJ (d-d) and RJ (rms).

When Sampling Mode is Advanced Jitter

Jitter analysis is executed for the waveform measured in Pulse mode of Scope.

Jitter is measured for each point of bit rising and falling.

Therefore, TJ, Bathtub, RJ/PJ Histogram, DDJ Histogram, Composite Histogram, Jitter Spectrum Display (PJ vs Frequency), and Jitter Display for each bit (DDJ vs Bit or PDJ vs Bit) can be measured.

Jitter Analysis (Advanced Jitter) allows jitter analysis for waveforms up to 32768 of pattern length.

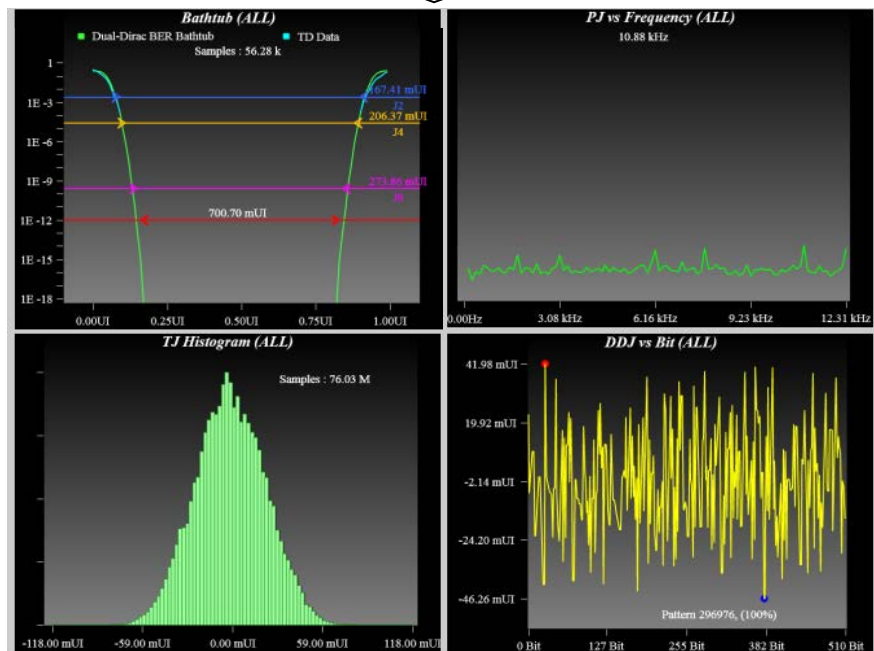
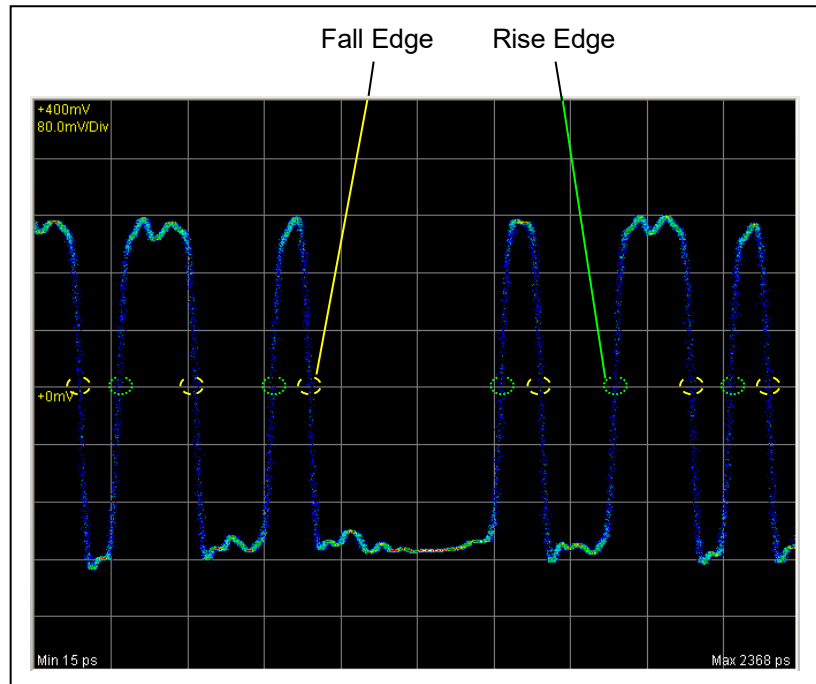

Figure 6.9.3-3 Measured Part and Display Example of Jitter Analysis (Advanced Jitter)

Jitter Analysis (Eye)

1. Click **Scope**.
2. Click **Setup** and set Sampling Mode to **Eye**. Set Signal Type to **NRZ** if it is displayed.
3. Click **Time** and set Data Clock Rate and Pattern Length.
4. Click **Sampling** to display **Sampling Run** at the button display.
5. Click **Auto Scale**.
6. To check NRZ? error, click **Measure** > **Amplitude/Time** tab.
7. Turn Display Result to **On**.
8. Check that the eye pattern is displayed at the center of screen and NRZ? error is not displayed.
9. Set Item Selection to **Item Type: Jitter**.
10. To select an item or items, click on the right column.
11. Click **Add**. The measurement item is displayed on the Result window.

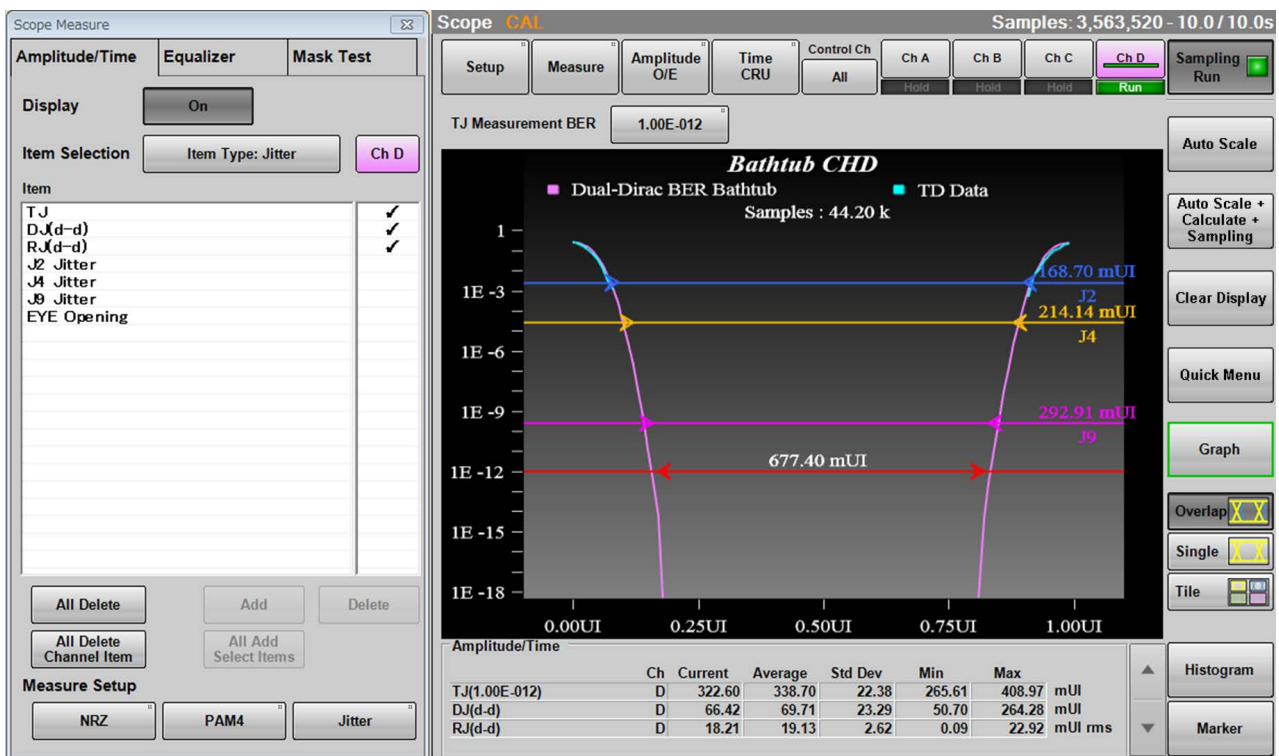

Figure 6.9.3-4 Display Example of Waveform

12. To change the measurement conditions, click **Jitter** of Measure Setup.

13. Click the TJ Measurement BER button to specify the BER to measure the eye aperture with the Bathtub graph.
Set the following items as needed.
Fixed RJ, RJ Value, Correction Factor, DJ (Scale), RJ (Scale), RJ (rms), Define Threshold, Manual Crossing
14. Click **Sampling** to display **Sampling Run** at the button display.
15. Click **Graph** on the Result window. Click the Graph selection buttons to display the jitter graph.

Jitter Analysis (Advanced Jitter)

1. Click **Scope**.
2. Click **Setup** to set Sampling Mode to **Advanced Jitter**. Set Signal Type to **NRZ** if it is displayed.
3. Click the Limit Type button to set the limitation method for data to be measured. Proceed to step 5 when **None** is set.
4. Set Time, Waveforms, Sampling, or Patterns depending on the Limit Type setting.
5. Click **Time CRU**.
6. Click **Scale Offset** tab.
7. Set Pattern Length.
When Tracking is set to **On**, select a PPG for Master.
When Tracking is set to **Off**, set the value for Length.

Note:

The larger the Pattern Length value becomes, the longer it takes to display the measurement results. It takes up to one minute.

8. Click **Measure**.
9. Click **Amplitude/Time** tab.
10. To select an item or items, click on the right column.
11. Click **Add**. The measurement item is displayed on the Result window.
12. Click **Jitter** of Measure Setup.
13. Click **Algorithm** tab.
14. When PDJ measurement is executed, click the PDJ measurement button to set the display to **On**. Proceed to step 14 when **Off** is set.
15. Click the Standard button to specify the standard to be applied to the PDJ measurement.
16. Click the PDJ Filter button to specify the filter to be applied to the PDJ measurement.

For the combination of standards and filters, refer to “Table 6.2.4-5

Settable Standards for PDJ Measurement and Filter Sets (Unit Hz)”.
 17. Click the Measurement Edge Type button to set the edge for jitter measurement.

All: Rising edge and falling edge

Falling: Only falling edge

Rising: Only rising edge

18. Click **Advanced** tab.

19. Click the TJ Measurement BER button to specify the BER to measure the eye aperture with the Bathtub graph.

Set the following items as needed.

Fixed RJ, RJ Value, Correction Factor, DJ (Scale), RJ (Scale), RJ (rms), Define Threshold, Manual Crossing

20. Click **Sampling** to display **Sampling Run** at the button display.

21. Click **Graph** on the Result window. Click the button on the scroll bar to display the jitter graph.

Starting/finishing Analysis

To start the jitter analysis, click **Sampling** on the Result window. The button lamp lights green during the analysis.

“Processing” is displayed on the screen until the analysis result is displayed.

When clicking **Sampling** during the analysis, the button lamp is lit off and then the analysis is finished.

For **Pattern**, **Sample**, **Time**, or **Waveforms** of the Limit Type on **General** tab of Setup dialog box, when jitter analysis data reaches to the limitation, the measurement is finished.

Note:

During jitter analysis, the following options and button are unavailable.

- **Open** system menu
- **Scope** and **All Setups** for **Save** system menu
- The All Measurements stop button (⊘ is displayed.)



The following message dialogs are displayed when analysis errors occur.

Table 6.9.3-1 Jitter Analysis Error Message

Message	Description
Illegal Error	An unexpected error has occurred.
NRZ?	NRZ? error has occurred in Scope. Change settings of Scope so that NRZ? error will not occur.
Pattern Lost	The set pattern length does not meet the actual pattern length. Set Pattern Length of Scope correctly.
TIE Error*	The jitter has exceeded 1 UI.
Time Out	Data cannot be acquired from Scope. Confirm that waveform displays in Scope.

*: Time Interval Error

6.9.4 Measurement Using Histogram

The histogram display displays the data distribution in the set field to measure the mean, standard deviation, and dispersion width.

To display histogram, set the axis, time, or amplitude for measuring histogram. And then, set the screen area to display histogram using the histogram marker. Also, the histogram marker position can be set by clicking the screen or using the mouse.

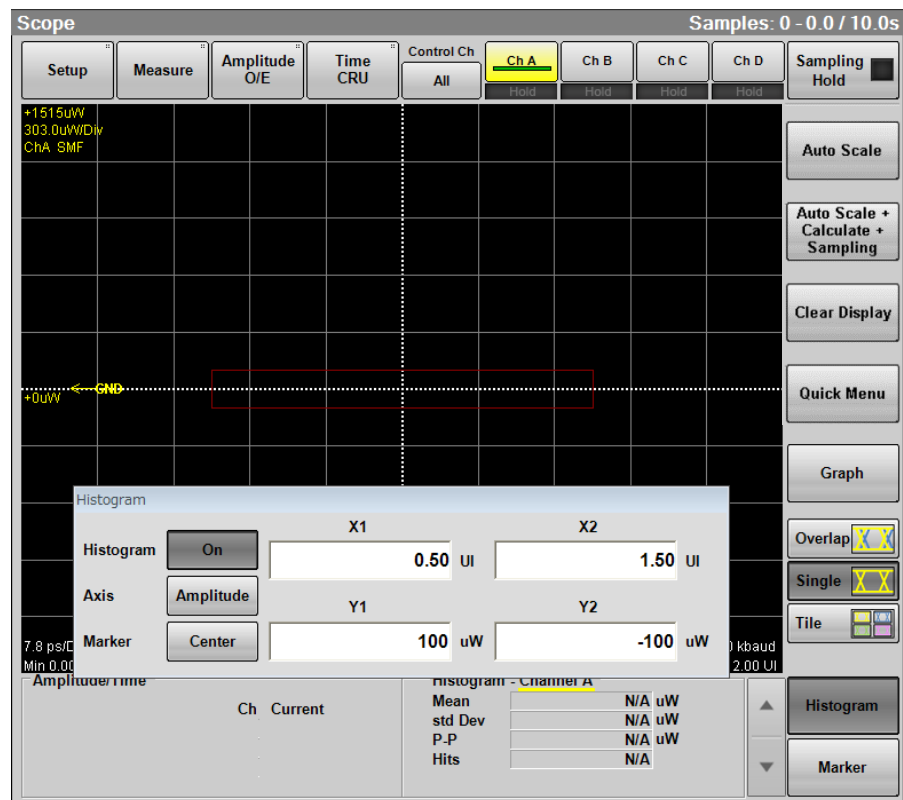
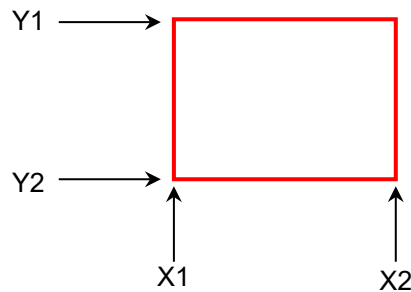

Figure 6.9.4-1 Setting Example of Histogram Measurement

1. Click **Histogram** to open the Histogram panel. The Histogram panel can be moved anywhere on the Scope window.
2. Click the Histogram button and set the display to **On**.
3. To measure the histogram in the time direction, click the Axis button to change it to **Time**.
To measure the histogram in the amplitude direction, click the Axis button to change it to **Amplitude**.
4. Input the value to the histogram marker X1, X2, Y1, and Y2, and then set the area.
The area border to set the histogram marker is as shown in the following figure.



When the graph display mode is **Overlap** or **Single**, the histogram marker position can also be changed by clicking the screen and dragging the marker.

5. The measurement result of the data within the area is displayed.
Mean: average value
Std Dev: standard deviation
P-P: difference between maximum value and minimum value
(Peak to Peak)
Hits: data count within area

To Histogram marker at screen center:

Click **Center** at Marker to center the marker in the middle of screen.

When histogram measurement is turned on, depending upon the previous settings, the X and Y coordinates of the histogram window may be set beyond the boundaries of the current display screen. If this occurs, clicking **Center** makes it easy to set the area.

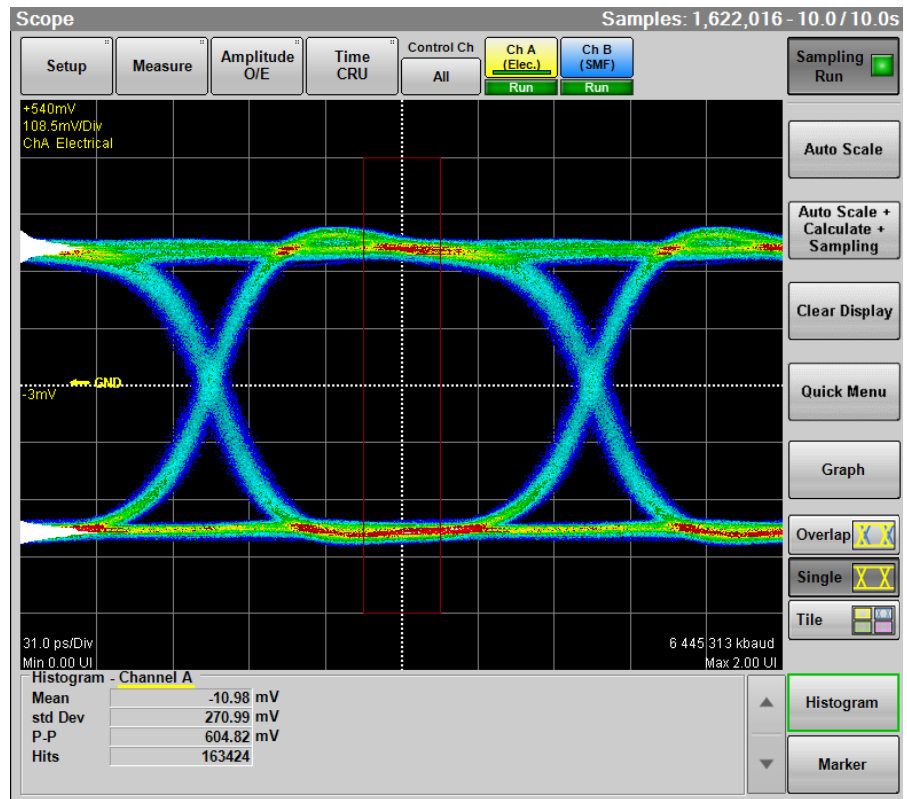

Figure 6.9.4-2 Histogram Measurement Example (Amplitude)

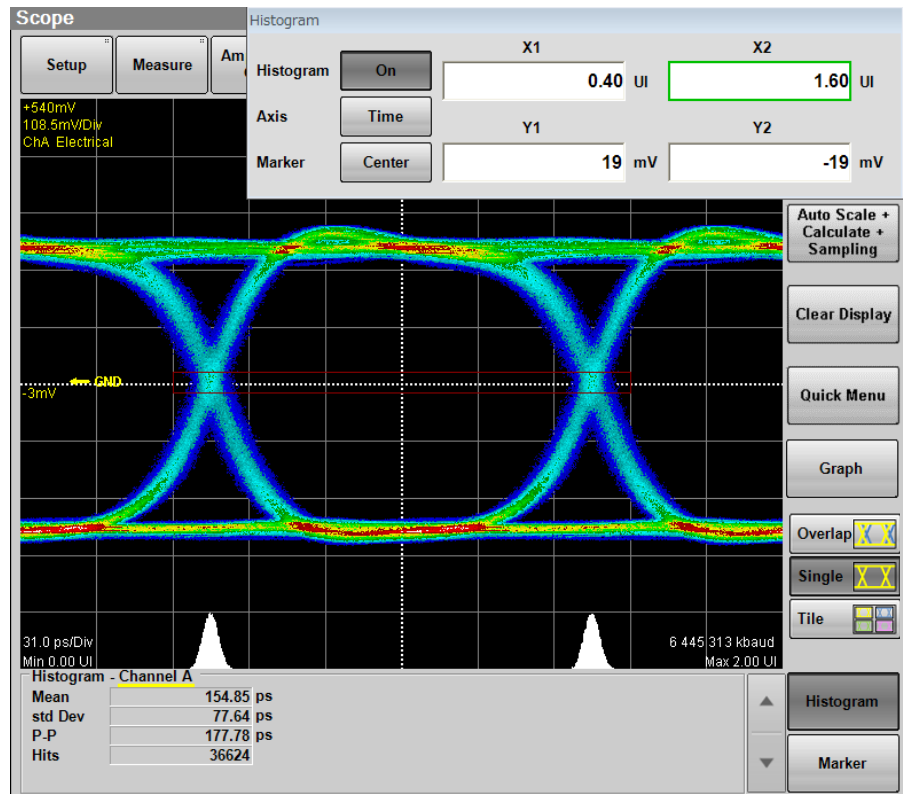

Figure 6.9.4-3 Histogram Measurement Example (Time)

6.9.5 Using Marker

The marker is used to read the amplitude and time values of the waveform.

Also, the level and time differences between two points can be measured.

There are two markers each for the x- and y-axes. Display of each marker can be set to on or off separately.

1. Click **Marker** to display the marker panel.

The marker panel can be moved in the Scope window.

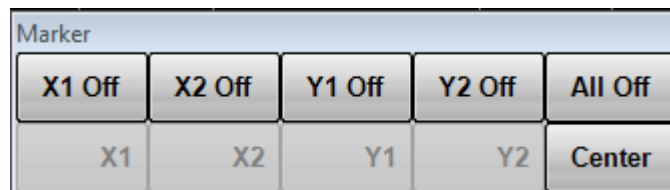

2. To display the marker, click the upper line buttons other than **All Off**. When the marker is displayed, the lower line buttons are invalid.
3. To move the marker, click the lower line buttons other than **Center**. The selected marker button is changed to the in-use display, and then the icon is displayed.



4. Set the marker position using the mouse wheel.

The marker position and time/level differences are displayed.

When the graph display mode is **Overlap** or **Single**, the histogram marker position can also be changed by clicking the screen and dragging the marker.

Marker Panel

X1 Off, X1 On, X2 Off, X2 On, Y1 Off, Y1 On, Y2 Off, Y2 On	Sets marker display
X1, X2, Y1, Y2	Selects marker to be moved
Center	Centers marker in the screen
All Off	Hide all markers

When the measurement result is displayed, click at the left side of **Marker** to switch the marker display.

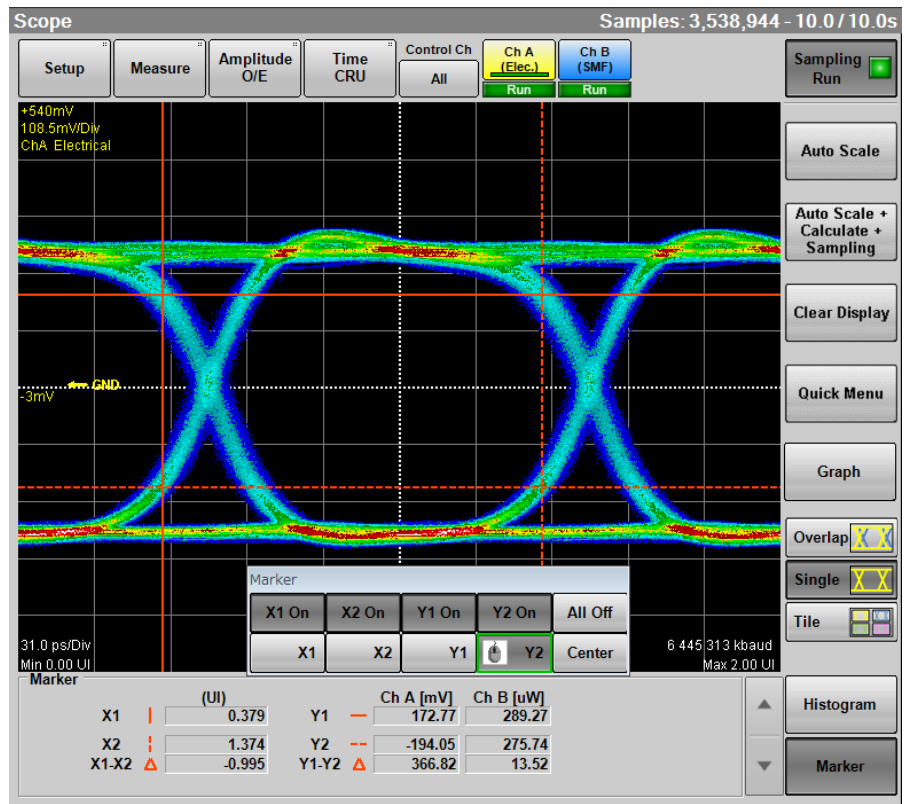

Figure 6.9.5-1 Marker Display

6.9.6 Displaying Waveform Calculation

MP2110A-x21 can display the math results of two waveforms of CH A and CH B as different waveforms. The calculated math results can be measured at Section 6.9.1 “Setting and Displaying Measurement Items”.

Note:

When calculating the EYE pattern waveform, set Sampling Mode to **Coherent Eye** and collect the data.

If Sampling Mode is set to **Eye** and data is collected, a computational error occurs.

Setting waveform calculation method and vertical scale

1. Click **Amplitude** to open the Amplitude dialog box.
2. Click the Channel Math button to set the button display to **On**.
3. Click the Define Function button and select the calculation method from the following:

CH A + CH B

CH A – CH B

CH B – CH A

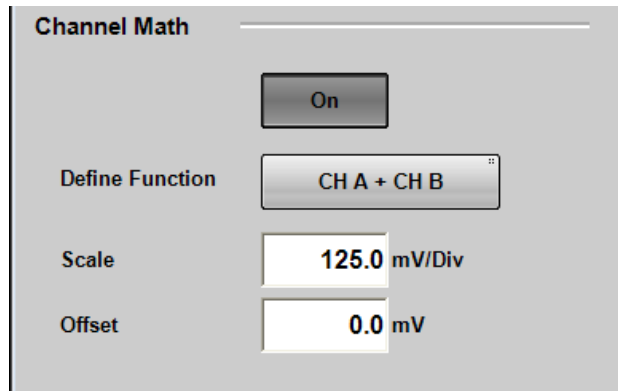

4. Click the Scale text box.
5. Input the voltage per vertical scale.
6. Click the Offset text box.
7. Input the voltage for the center of the vertical scale.

For the adjustment method of the time axis, refer to 6.8.3 “Adjusting Horizontal Axis”.

Even when the calculated waveform is displayed, **Auto Scale** works.

To close the waveform calculation display, click the Channel Math button and set the button display to **Off**.

6.9.7 Using Trace Memory

The trace memory is a function to save the measurement waveform in the memory.

The waveform saved in the trace memory calls the reference trace.

To save the waveform in the trace memory

1. Click **Setup** to open the Setup dialog box.
2. Select a channel or channels for waveform display by clicking the Trace switch buttons.
3. Click the **Utilities** tab.
4. Click **Set** of Reference.



The trace waveform is displayed in the screen.

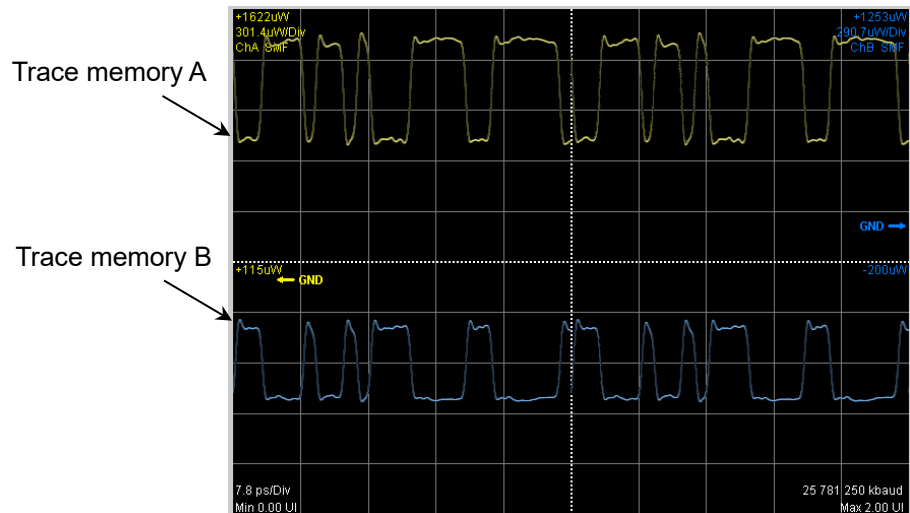

Figure 6.9.7-1 Waveform Display of Trace Memory

To delete the trace memory waveform

1. Click **Setup** to open the Setup dialog box.
2. Click the **Utilities** tab.
3. Click **Clear** of Reference.

Clear Display does not delete the waveforms saved to the trace memory.

6.9.8 Displaying a Label

This section describes how to display an arbitrary string (label) in the Scope screen.

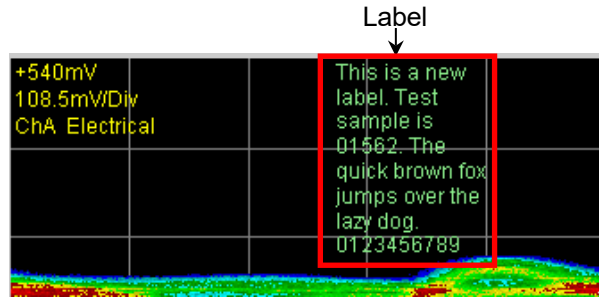

Figure 6.9.8-1 Label Display

Displaying labels

Channels subject to label display vary depending on the graph display mode.

Overlap: Displays the label for the active channel.

Single. Tile: Displays the labels for all channels.

Also, the channels subject to label addition vary depending on the Control Ch setting.

All: Adds labels to all channels.

Single: Adds a label to the active channel.

1. Click **Setup** to open the Setup dialog box.
2. Click **Utilities** tab.
3. Set **Preset Information** to **Off** to specify the start position of label display. Set **Preset Information** to **On** to display the label at the fixed area as shown in Figure 6.9.8-1.
4. Click **Add** of Label to enter the character string for a new label. Inputting a line feed code (`\n`) starts a new line. When **Preset Information** is set to **Off** at step 3, specify the start position of label display (in the waveform display area, the position of upper left is (0, 0) and the position of lower right is (665, 497)).
5. Click **OK** on the software keyboard, and the label is displayed on the screen.

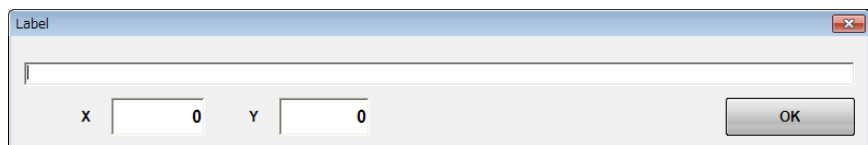

Figure 6.9.8-2 Label Dialog Box

Note:

Up to 1023 characters can be entered. However, all characters may not be displayed because the characters that can be displayed are limited.

The color of the label cannot be changed.

Deleting the displayed label

The channels subject to label deletion vary depending on the Control Ch setting.

All Deletes labels for all channels.

Single Deletes the label for the active channel.

1. Click **Setup** to open the Setup dialog box.
2. Click **Utilities** tab.
3. Click **Delete** for Label, and the displayed label is deleted.

6.9.9 Saving Measurement Results

The sampling oscilloscope results can be saved in the following file types:

- **Screen image**
The image of the entire screen or only the measurement screen is saved to a PNG or JPEG file.
- **Measurement result**
The waveform is saved as a text file or CSV file.
- **Measurement conditions**
The setting values in the Amplitude, Measurement, Setup, and Time dialog boxes are saved to a file.

To save screen image
When saving the entire screen

1. Click **Screen Copy** at the system menu. The **File** dialog box is displayed.

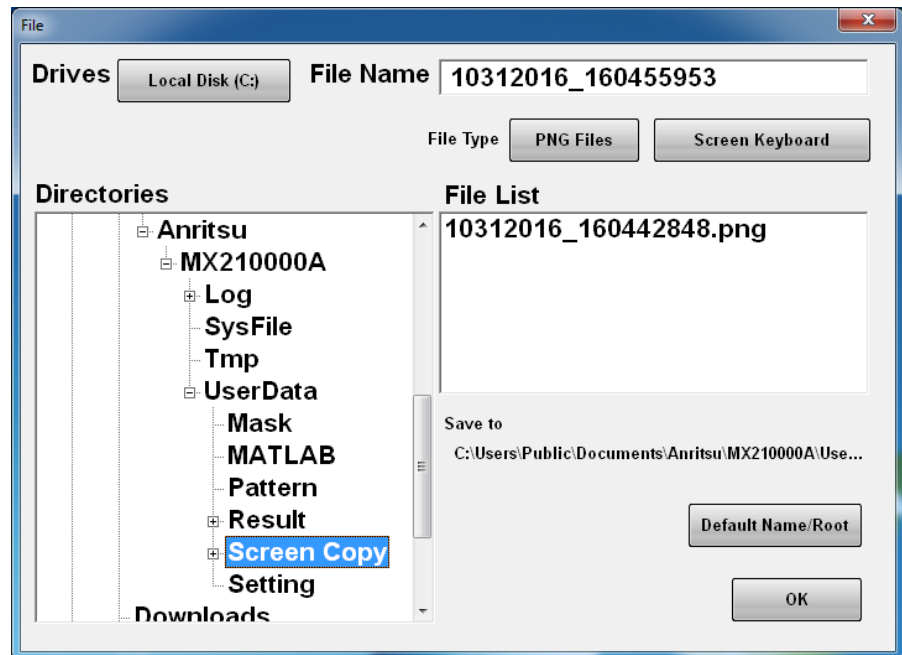

2. Click the Drives button and the Directories field to set the save destination folder. The path to the save folder is displayed at the Save to field.
3. The file format to be saved is displayed in the right button of the file type. Clicking the button can set the file format.
4. To set the file name, click **Screen Keyboard** and input the file name.
5. When overwriting an existing file, click the file name displayed at File List.
6. Click **OK** to save the screen image.
When overwriting a file, a **File** dialog box is displayed.

The path to the default folder is:

C:\Users\Public\Documents\Anritsu\MX21000A\UserData\Screen Copy

The date and time are recorded in the default file name.

When saving the measurement screen:

1. Click **Setup**.
2. Click **Save**.
3. To save the waveform as a color image, select **Color Grade** at Waveform Color .
To save the waveform as a monochrome image, select **Gray Scale** at Waveform Color.
4. To save both waveform and measurement results as an image, switch the option for Waveforms only to **Off**.
To save only the waveform as an image, switch the option for Waveforms only to **On**.
5. To save a screenshot using monitor color, set Inverse background color to **Off**.
To reverse the screen color, set Inverse background color to **On**.

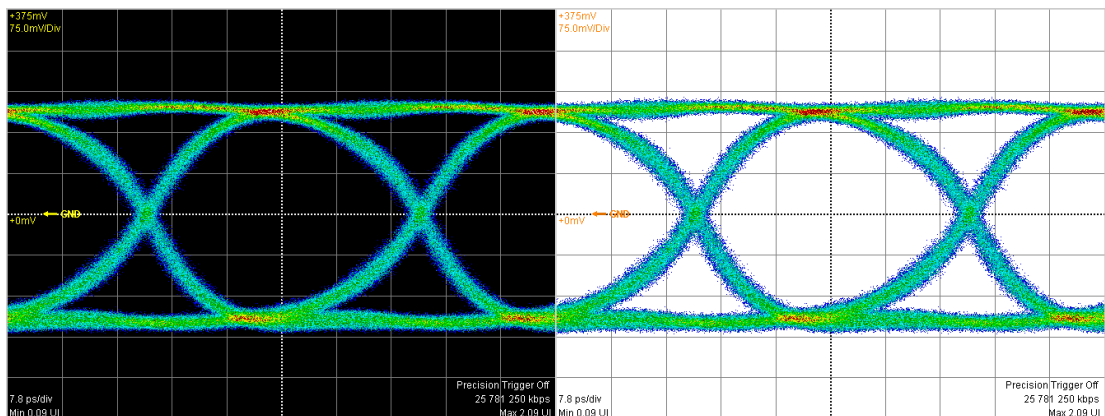

Inverse Off

Inverse On

6. Click **Capture**. The **File** dialog box same as the entire screen to be saved is displayed.
7. Set the file format, folder and file name and click **OK**.
8. The image png file is saved in the following path when the folder is set to the default.

C:\Users\Public\Documents\Anritsu\MX210000A\UserData\Screen Copy

Amplitude/Time Measurement and Histogram
Measurement - Channel A

[Setups]

Axis Amplitude
X1 Marker 0.50UI
X2 Marker 1.50UI
Y1 Marker 98mV
Y2 Marker -101mV

When Histogram
is On

[Results]

One Level Ch A N/A N/A N/A N/A N/A
One Level Ch B N/A N/A N/A N/A N/A
One Level Ch C N/A N/A N/A N/A N/A
One Level Ch D 257.15 257.16 0.15 256.74 257.43
Zero Level Ch A N/A N/A N/A N/A N/A
Zero Level Ch B N/A N/A N/A N/A N/A
Zero Level Ch C N/A N/A N/A N/A N/A
Zero Level Ch D 100.38 100.35 0.03 100.15 100.49
Eye Amplitude Ch A N/A N/A N/A N/A N/A
Eye Amplitude Ch B N/A N/A N/A N/A N/A
Eye Amplitude Ch C N/A N/A N/A N/A N/A
Eye Amplitude Ch D 156.77 156.81 0.17 156.25 157.28
Eye Height Ch A N/A N/A N/A N/A N/A
Eye Height Ch B N/A N/A N/A N/A N/A
Eye Height Ch C N/A N/A N/A N/A N/A
Eye Height Ch D 80.99 81.07 0.16 80.66 82.15
Crossing Ch A N/A N/A N/A N/A N/A
Crossing Ch B N/A N/A N/A N/A N/A
Crossing Ch C N/A N/A N/A N/A N/A
Crossing Ch D 47.01 47.01 0.06 46.95 47.68
SNR Ch A N/A N/A N/A N/A N/A
SNR Ch B N/A N/A N/A N/A N/A
SNR Ch C N/A N/A N/A N/A N/A
SNR Ch D 6.21 6.21 0.01 6.20 6.28
Average Power (dBm) Ch A N/A N/A N/A N/A N/A
Average Power (dBm) Ch B N/A N/A N/A N/A N/A
Average Power (dBm) Ch C N/A N/A N/A N/A N/A
Average Power (dBm) Ch D -7.50 -7.51 0.02 -7.57 -7.50
Average Power (mW) Ch A N/A N/A N/A N/A N/A
Average Power (mW) Ch B N/A N/A N/A N/A N/A
Average Power (mW) Ch C N/A N/A N/A N/A N/A
Average Power (mW) Ch D 0.18 0.18 0.00 0.18 0.18
Extinction Ratio Ch A N/A N/A N/A N/A N/A
Extinction Ratio Ch B N/A N/A N/A N/A N/A
Extinction Ratio Ch C N/A N/A N/A N/A N/A
Extinction Ratio Ch D 4.43 4.43 0.00 4.42 4.45
Jitter P-P Ch A N/A N/A N/A N/A N/A
Jitter P-P Ch B N/A N/A N/A N/A N/A
Jitter P-P Ch C N/A N/A N/A N/A N/A
Jitter P-P Ch D 11.43 11.18 0.41 7.35 11.43
Jitter RMS Ch A N/A N/A N/A N/A N/A
Jitter RMS Ch B N/A N/A N/A N/A N/A
Jitter RMS Ch C N/A N/A N/A N/A N/A
Jitter RMS Ch D 1.59 1.59 0.01 1.58 1.70

Rise Time Ch A N/A N/A N/A N/A N/A
Rise Time Ch B N/A N/A N/A N/A N/A
Rise Time Ch C N/A N/A N/A N/A N/A
Rise Time Ch D 17.49 17.45 0.13 15.51 17.53
Fall Time Ch A N/A N/A N/A N/A N/A
Fall Time Ch B N/A N/A N/A N/A N/A
Fall Time Ch C N/A N/A N/A N/A N/A
Fall Time Ch D 21.07 21.05 0.04 20.80 21.38
Eye Width Ch A N/A N/A N/A N/A N/A
Eye Width Ch B N/A N/A N/A N/A N/A
Eye Width Ch C N/A N/A N/A N/A N/A
Eye Width Ch D 29.30 29.30 0.05 28.65 29.36
DCD Ch A N/A N/A N/A N/A N/A
DCD Ch B N/A N/A N/A N/A N/A
DCD Ch C N/A N/A N/A N/A N/A
DCD Ch D 6.32 6.13 0.91 3.61 10.53
OMA (mW) Ch A N/A N/A N/A N/A N/A
OMA (mW) Ch B N/A N/A N/A N/A N/A
OMA (mW) Ch C N/A N/A N/A N/A N/A
OMA (mW) Ch D 0.16 0.16 0.00 0.16 0.16
OMA (dBm) Ch A N/A N/A N/A N/A N/A
OMA (dBm) Ch B N/A N/A N/A N/A N/A
OMA (dBm) Ch C N/A N/A N/A N/A N/A
OMA (dBm) Ch D -8.05 -8.05 0.00 -8.06 -8.03
OMA at Crossing Ch A N/A N/A N/A N/A N/A
OMA at Crossing Ch B N/A N/A N/A N/A N/A
OMA at Crossing Ch C N/A N/A N/A N/A N/A
OMA at Crossing Ch D 167.67 167.74 0.28 166.52 170.62
VECP Ch A N/A N/A N/A N/A N/A
VECP Ch B N/A N/A N/A N/A N/A
VECP Ch C N/A N/A N/A N/A N/A
VECP Ch D 2.55 2.54 0.05 2.02 2.59
TDEC Ch A N/A N/A N/A N/A N/A
TDEC Ch B N/A N/A N/A N/A N/A
TDEC Ch C N/A N/A N/A N/A N/A
TDEC Ch D N/A N/A N/A N/A N/A
Eye Height (Ratio) Ch A N/A N/A N/A N/A N/A
Eye Height (Ratio) Ch B N/A N/A N/A N/A N/A
Eye Height (Ratio) Ch C N/A N/A N/A N/A N/A
Eye Height (Ratio) Ch D N/A N/A N/A N/A N/A
RIN OMA Ch A N/A N/A N/A N/A N/A
RIN OMA Ch B N/A N/A N/A N/A N/A
RIN OMA Ch C N/A N/A N/A N/A N/A
RIN OMA Ch D N/A N/A N/A N/A N/A
Crossing Time Ch A N/A N/A N/A N/A N/A
Crossing Time Ch B N/A N/A N/A N/A N/A
Crossing Time Ch C N/A N/A N/A N/A N/A
Crossing Time Ch D N/A N/A N/A N/A N/A
Amplitude P-P Ch A N/A N/A N/A N/A N/A
Amplitude P-P Ch B N/A N/A N/A N/A N/A
Amplitude P-P Ch C N/A N/A N/A N/A N/A
Amplitude P-P Ch D N/A N/A N/A N/A N/A

Figure 6.9.9-2 Result File Example (1)

TDECQ Ch A N/A N/A N/A N/A N/A	Level(0) Ch B N/A N/A N/A N/A N/A
TDECQ Ch B N/A N/A N/A N/A N/A	Level(0) Ch C N/A N/A N/A N/A N/A
TDECQ Ch C N/A N/A N/A N/A N/A	Level(0) Ch D N/A N/A N/A N/A N/A
TDECQ Ch D N/A N/A N/A N/A N/A	Level(3) RMS Ch A N/A N/A N/A N/A N/A
Outer OMA(dBm) Ch A N/A N/A N/A N/A N/A	Level(3) RMS Ch B N/A N/A N/A N/A N/A
Outer OMA(dBm) Ch B N/A N/A N/A N/A N/A	Level(3) RMS Ch C N/A N/A N/A N/A N/A
Outer OMA(dBm) Ch C N/A N/A N/A N/A N/A	Level(3) RMS Ch D N/A N/A N/A N/A N/A
Outer OMA(dBm) Ch D N/A N/A N/A N/A N/A	Level(2) RMS Ch A N/A N/A N/A N/A N/A
Outer OMA(uW) Ch A N/A N/A N/A N/A N/A	Level(2) RMS Ch B N/A N/A N/A N/A N/A
Outer OMA(uW) Ch B N/A N/A N/A N/A N/A	Level(2) RMS Ch C N/A N/A N/A N/A N/A
Outer OMA(uW) Ch C N/A N/A N/A N/A N/A	Level(2) RMS Ch D N/A N/A N/A N/A N/A
Outer OMA(uW) Ch D N/A N/A N/A N/A N/A	Level(1) RMS Ch A N/A N/A N/A N/A N/A
Outer ExR Ch A N/A N/A N/A N/A N/A	Level(1) RMS Ch B N/A N/A N/A N/A N/A
Outer ExR Ch B N/A N/A N/A N/A N/A	Level(1) RMS Ch C N/A N/A N/A N/A N/A
Outer ExR Ch C N/A N/A N/A N/A N/A	Level(1) RMS Ch D N/A N/A N/A N/A N/A
Outer ExR Ch D N/A N/A N/A N/A N/A	Level(0) RMS Ch A N/A N/A N/A N/A N/A
Linearity(CL_94) Ch A N/A N/A N/A N/A N/A	Level(0) RMS Ch B N/A N/A N/A N/A N/A
Linearity(CL_94) Ch B N/A N/A N/A N/A N/A	Level(0) RMS Ch C N/A N/A N/A N/A N/A
Linearity(CL_94) Ch C N/A N/A N/A N/A N/A	Level(0) RMS Ch D N/A N/A N/A N/A N/A
Linearity(CL_94) Ch D N/A N/A N/A N/A N/A	Level(3) P-P Ch A N/A N/A N/A N/A N/A
Ceq Ch A N/A N/A N/A N/A N/A	Level(3) P-P Ch B N/A N/A N/A N/A N/A
Ceq Ch B N/A N/A N/A N/A N/A	Level(3) P-P Ch C N/A N/A N/A N/A N/A
Ceq Ch C N/A N/A N/A N/A N/A	Level(3) P-P Ch D N/A N/A N/A N/A N/A
Ceq Ch D N/A N/A N/A N/A N/A	Level(2) P-P Ch A N/A N/A N/A N/A N/A
RIN OMA Ch A N/A N/A N/A N/A N/A	Level(2) P-P Ch B N/A N/A N/A N/A N/A
RIN OMA Ch B N/A N/A N/A N/A N/A	Level(2) P-P Ch C N/A N/A N/A N/A N/A
RIN OMA Ch C N/A N/A N/A N/A N/A	Level(2) P-P Ch D N/A N/A N/A N/A N/A
RIN OMA Ch D N/A N/A N/A N/A N/A	Level(1) P-P Ch A N/A N/A N/A N/A N/A
Transition Time (Rise) Ch A N/A N/A N/A N/A N/A	Level(1) P-P Ch B N/A N/A N/A N/A N/A
Transition Time (Rise) Ch B N/A N/A N/A N/A N/A	Level(1) P-P Ch C N/A N/A N/A N/A N/A
Transition Time (Rise) Ch C N/A N/A N/A N/A N/A	Level(1) P-P Ch D N/A N/A N/A N/A N/A
Transition Time (Rise) Ch D N/A N/A N/A N/A N/A	Level(0) P-P Ch A N/A N/A N/A N/A N/A
Transition Time (Fall) Ch A N/A N/A N/A N/A N/A	Level(0) P-P Ch B N/A N/A N/A N/A N/A
Transition Time (Fall) Ch B N/A N/A N/A N/A N/A	Level(0) P-P Ch C N/A N/A N/A N/A N/A
Transition Time (Fall) Ch C N/A N/A N/A N/A N/A	Level(0) P-P Ch D N/A N/A N/A N/A N/A
Transition Time (Fall) Ch D N/A N/A N/A N/A N/A	Level(3) Skew Ch A N/A N/A N/A N/A N/A
Transition Time (Slow) Ch A N/A N/A N/A N/A N/A	Level(3) Skew Ch B N/A N/A N/A N/A N/A
Transition Time (Slow) Ch B N/A N/A N/A N/A N/A	Level(3) Skew Ch C N/A N/A N/A N/A N/A
Transition Time (Slow) Ch C N/A N/A N/A N/A N/A	Level(3) Skew Ch D N/A N/A N/A N/A N/A
Transition Time (Slow) Ch D N/A N/A N/A N/A N/A	Level(2) Skew Ch A N/A N/A N/A N/A N/A
Level(3) Ch A N/A N/A N/A N/A N/A	Level(2) Skew Ch B N/A N/A N/A N/A N/A
Level(3) Ch B N/A N/A N/A N/A N/A	Level(2) Skew Ch C N/A N/A N/A N/A N/A
Level(3) Ch C N/A N/A N/A N/A N/A	Level(2) Skew Ch D N/A N/A N/A N/A N/A
Level(3) Ch D N/A N/A N/A N/A N/A	Level(1) Skew Ch A N/A N/A N/A N/A N/A
Level(2) Ch A N/A N/A N/A N/A N/A	Level(1) Skew Ch B N/A N/A N/A N/A N/A
Level(2) Ch B N/A N/A N/A N/A N/A	Level(1) Skew Ch C N/A N/A N/A N/A N/A
Level(2) Ch C N/A N/A N/A N/A N/A	Level(1) Skew Ch D N/A N/A N/A N/A N/A
Level(2) Ch D N/A N/A N/A N/A N/A	Level(0) Skew Ch A N/A N/A N/A N/A N/A
Level(1) Ch A N/A N/A N/A N/A N/A	Level(0) Skew Ch B N/A N/A N/A N/A N/A
Level(1) Ch B N/A N/A N/A N/A N/A	Level(0) Skew Ch C N/A N/A N/A N/A N/A
Level(1) Ch C N/A N/A N/A N/A N/A	Level(0) Skew Ch D N/A N/A N/A N/A N/A
Level(1) Ch D N/A N/A N/A N/A N/A	Eye(Upper) Level Ch A N/A N/A N/A N/A N/A
Level(0) Ch A N/A N/A N/A N/A N/A	Eye(Upper) Level Ch B N/A N/A N/A N/A N/A

When MP2110A-x95 is installed

When MP2110A-x95 is installed

Figure 6.9.9-3 Result File Example (2)

Eye(Upper) Level Ch C N/A N/A N/A N/A N/A
 Eye(Upper) Level Ch D N/A N/A N/A N/A N/A
 Eye(Middle) Level Ch A N/A N/A N/A N/A N/A
 Eye(Middle) Level Ch B N/A N/A N/A N/A N/A
 Eye(Middle) Level Ch C N/A N/A N/A N/A N/A
 Eye(Middle) Level Ch D N/A N/A N/A N/A N/A
 Eye(Lower) Level Ch A N/A N/A N/A N/A N/A
 Eye(Lower) Level Ch B N/A N/A N/A N/A N/A
 Eye(Lower) Level Ch C N/A N/A N/A N/A N/A
 Eye(Lower) Level Ch D N/A N/A N/A N/A N/A
 Eye(Upper) Skew Ch A N/A N/A N/A N/A N/A
 Eye(Upper) Skew Ch B N/A N/A N/A N/A N/A
 Eye(Upper) Skew Ch C N/A N/A N/A N/A N/A
 Eye(Upper) Skew Ch D N/A N/A N/A N/A N/A
 Eye(Middle) Skew Ch A N/A N/A N/A N/A N/A
 Eye(Middle) Skew Ch B N/A N/A N/A N/A N/A
 Eye(Middle) Skew Ch C N/A N/A N/A N/A N/A
 Eye(Middle) Skew Ch D N/A N/A N/A N/A N/A
 Eye(Lower) Skew Ch A N/A N/A N/A N/A N/A
 Eye(Lower) Skew Ch B N/A N/A N/A N/A N/A
 Eye(Lower) Skew Ch C N/A N/A N/A N/A N/A
 Eye(Lower) Skew Ch D N/A N/A N/A N/A N/A
 Eye(Upper) Height Ch A N/A N/A N/A N/A N/A
 Eye(Upper) Height Ch B N/A N/A N/A N/A N/A
 Eye(Upper) Height Ch C N/A N/A N/A N/A N/A
 Eye(Upper) Height Ch D N/A N/A N/A N/A N/A
 Eye(Middle) Height Ch A N/A N/A N/A N/A N/A
 Eye(Middle) Height Ch B N/A N/A N/A N/A N/A
 Eye(Middle) Height Ch C N/A N/A N/A N/A N/A
 Eye(Middle) Height Ch D N/A N/A N/A N/A N/A
 Eye(Lower) Height Ch A N/A N/A N/A N/A N/A
 Eye(Lower) Height Ch B N/A N/A N/A N/A N/A
 Eye(Lower) Height Ch C N/A N/A N/A N/A N/A
 Eye(Lower) Height Ch D N/A N/A N/A N/A N/A
 Eye(Upper) Width Ch A N/A N/A N/A N/A N/A
 Eye(Upper) Width Ch B N/A N/A N/A N/A N/A
 Eye(Upper) Width Ch C N/A N/A N/A N/A N/A
 Eye(Upper) Width Ch D N/A N/A N/A N/A N/A
 Eye(Middle) Width Ch A N/A N/A N/A N/A N/A
 Eye(Middle) Width Ch B N/A N/A N/A N/A N/A
 Eye(Middle) Width Ch C N/A N/A N/A N/A N/A
 Eye(Middle) Width Ch D N/A N/A N/A N/A N/A
 Eye(Lower) Width Ch A N/A N/A N/A N/A N/A
 Eye(Lower) Width Ch B N/A N/A N/A N/A N/A
 Eye(Lower) Width Ch C N/A N/A N/A N/A N/A
 Eye(Lower) Width Ch D N/A N/A N/A N/A N/A
 Average Power (dBm) Ch A N/A N/A N/A N/A N/A
 Average Power (dBm) Ch B N/A N/A N/A N/A N/A
 Average Power (dBm) Ch C N/A N/A N/A N/A N/A
 Average Power (dBm) Ch D -7.50 -7.51 0.02 -7.57 -7.50
 Average Power (mW) Ch A N/A N/A N/A N/A N/A
 Average Power (mW) Ch B N/A N/A N/A N/A N/A
 Average Power (mW) Ch C N/A N/A N/A N/A N/A

When MP2110A-x95 is installed

Average Power (mW) Ch D 0.18 0.18 0.00 0.18 0.18
 TDECQ (Upper/Left) Ch A N/A N/A N/A N/A N/A
 TDECQ (Upper/Left) Ch B N/A N/A N/A N/A N/A
 TDECQ (Upper/Left) Ch C N/A N/A N/A N/A N/A
 TDECQ (Upper/Left) Ch D N/A N/A N/A N/A N/A
 TDECQ (Upper/Right) Ch A N/A N/A N/A N/A N/A
 TDECQ (Upper/Right) Ch B N/A N/A N/A N/A N/A
 TDECQ (Upper/Right) Ch C N/A N/A N/A N/A N/A
 TDECQ (Upper/Right) Ch D N/A N/A N/A N/A N/A
 TDECQ (Middle/Left) Ch A N/A N/A N/A N/A N/A
 TDECQ (Middle/Left) Ch B N/A N/A N/A N/A N/A
 TDECQ (Middle/Left) Ch C N/A N/A N/A N/A N/A
 TDECQ (Middle/Left) Ch D N/A N/A N/A N/A N/A
 TDECQ (Middle/Right) Ch A N/A N/A N/A N/A N/A
 TDECQ (Middle/Right) Ch B N/A N/A N/A N/A N/A
 TDECQ (Middle/Right) Ch C N/A N/A N/A N/A N/A
 TDECQ (Middle/Right) Ch D N/A N/A N/A N/A N/A
 TDECQ (Lower/Left) Ch A N/A N/A N/A N/A N/A
 TDECQ (Lower/Left) Ch B N/A N/A N/A N/A N/A
 TDECQ (Lower/Left) Ch C N/A N/A N/A N/A N/A
 TDECQ (Lower/Left) Ch D N/A N/A N/A N/A N/A
 TDECQ (Lower/Right) Ch A N/A N/A N/A N/A N/A
 TDECQ (Lower/Right) Ch B N/A N/A N/A N/A N/A
 TDECQ (Lower/Right) Ch C N/A N/A N/A N/A N/A
 TDECQ (Lower/Right) Ch D N/A N/A N/A N/A N/A
 Overshoot(1.00%) Ch A N/A N/A N/A N/A N/A
 Overshoot(1.00%) Ch B N/A N/A N/A N/A N/A
 Overshoot(1.00%) Ch C N/A N/A N/A N/A N/A
 Overshoot(1.00%) Ch D N/A N/A N/A N/A N/A
 Undershoot(1.00%) Ch A N/A N/A N/A N/A N/A
 Undershoot(1.00%) Ch B N/A N/A N/A N/A N/A
 Undershoot(1.00%) Ch C N/A N/A N/A N/A N/A
 Undershoot(1.00%) Ch D N/A N/A N/A N/A N/A
 P-P Power(1.00%) Ch A N/A N/A N/A N/A N/A
 P-P Power(1.00%) Ch B N/A N/A N/A N/A N/A
 P-P Power(1.00%) Ch C N/A N/A N/A N/A N/A
 P-P Power(1.00%) Ch D N/A N/A N/A N/A N/A
 Power Excursion(1.00%) Ch A N/A N/A N/A N/A N/A
 Power Excursion(1.00%) Ch B N/A N/A N/A N/A N/A
 Power Excursion(1.00%) Ch C N/A N/A N/A N/A N/A
 Power Excursion(1.00%) Ch D N/A N/A N/A N/A N/A
 Noise Margin Ch A N/A N/A N/A N/A N/A
 Noise Margin Ch B N/A N/A N/A N/A N/A
 Noise Margin Ch C N/A N/A N/A N/A N/A
 Noise Margin Ch D N/A N/A N/A N/A N/A
 Noise Margin (Upper/Left) Ch A N/A N/A N/A N/A N/A
 Noise Margin (Upper/Left) Ch B N/A N/A N/A N/A N/A
 Noise Margin (Upper/Left) Ch C N/A N/A N/A N/A N/A
 Noise Margin (Upper/Left) Ch D N/A N/A N/A N/A N/A
 Noise Margin (Upper/Right) Ch A N/A N/A N/A N/A N/A
 Noise Margin (Upper/Right) Ch B N/A N/A N/A N/A N/A
 Noise Margin (Upper/Right) Ch C N/A N/A N/A N/A N/A
 Noise Margin (Upper/Right) Ch D N/A N/A N/A N/A N/A

When MP2110A-x95 is installed

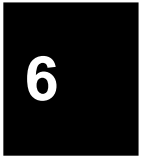

Figure 6.9.9-4 Result File Example (3)

```

Noise Margin (Middle/Left) Ch A N/A N/A N/A N/A N/A
Noise Margin (Middle/Left) Ch B N/A N/A N/A N/A N/A
Noise Margin (Middle/Left) Ch C N/A N/A N/A N/A N/A
Noise Margin (Middle/Left) Ch D N/A N/A N/A N/A N/A
Noise Margin (Middle/Right) Ch A N/A N/A N/A N/A N/A
Noise Margin (Middle/Right) Ch B N/A N/A N/A N/A N/A
Noise Margin (Middle/Right) Ch C N/A N/A N/A N/A
N/A
Noise Margin (Middle/Right) Ch D N/A N/A N/A N/A
N/A
Noise Margin (Lower/Left) Ch A N/A N/A N/A N/A N/A
Noise Margin (Lower/Left) Ch B N/A N/A N/A N/A N/A
Noise Margin (Lower/Left) Ch C N/A N/A N/A N/A N/A
Noise Margin (Lower/Left) Ch D N/A N/A N/A N/A N/A
Noise Margin (Lower/Right) Ch A N/A N/A N/A N/A N/A
Noise Margin (Lower/Right) Ch B N/A N/A N/A N/A N/A
Noise Margin (Lower/Right) Ch C N/A N/A N/A N/A N/A
Noise Margin (Lower/Right) Ch D N/A N/A N/A N/A N/A

Mean -0.43
Std Dev 68.17
P-P 196.47
Hits 209156
Hit Point Detail
98mV 65 Hits
96mV 58 Hits
95mV 56 Hits
93mV 57 Hits
91mV 49 Hits
89mV 46 Hits
88mV 50 Hits
:
-84mV 43 Hits
-86mV 42 Hits
-87mV 42 Hits
-89mV 48 Hits
-91mV 53 Hits
-92mV 54 Hits
-94mV 56 Hits
-96mV 59 Hits
-98mV 66 Hits
-99mV 0 Hits

Waveform
665x497
Ch A
0 0 0 0 0 0 0 ... (waveformdata)
:
Ch B
0 0 0 0 0 0 0 ... (waveformdata)
:
Ch C
0 0 0 0 0 0 0 ... (waveformdata)

```

When MP2110A-x95 is installed

When Histogram is On

```

:
Ch D
0 0 0 0 0 0 0 ... (waveformdata)
:
Jitter Measurement
[Setup]
Symbol Rate                25781271 kbaud
Divide Ratio                4
Pattern Length              511
Target Channel              CHD
Accumulation Type (CHD)    Infinite
Measure Algorithm           Histogram
TJ Measurement BER         1.00E-012
Fixed RJ                    OFF
RJ Value                    1.00 ps rms
Correction Factor           OFF
DJ (Scale) (CHA)           -
DJ (Scale) (CHB)           -
DJ (Scale) (CHC)           -
DJ (Scale) (CHD)           1.00
RJ (Scale)                  1.00
RJ (rms)                    1.00 ps
Define Threshold            Auto
Manual Crossing (CHA)      -
Manual Crossing (CHB)      -
Manual Crossing (CHC)      -
Manual Crossing (CHD)      50.00 %
Jitter Unit                 Time

[Jitter Measurement Results]
TJ(1.00E-012) (CHA)        -
TJ(1.00E-012) (CHB)        -
TJ(1.00E-012) (CHC)        -
TJ(1.00E-012) (CHD)        1.877575e-011
DJ(d-d) (CHA)              -
DJ(d-d) (CHB)              -
DJ(d-d) (CHC)              -
DJ(d-d) (CHD)              3.911747e-012
RJ(d-d) (CHA)              -
RJ(d-d) (CHB)              -
RJ(d-d) (CHC)              -
RJ(d-d) (CHD)              1.056525e-012
EYE Opening (CHA)          -
EYE Opening (CHB)          -
EYE Opening (CHC)          -
EYE Opening (CHD)          2.001209e-011
J2 Jitter (CHA)            -
J2 Jitter (CHB)            -
J2 Jitter (CHC)            -
J2 Jitter (CHD)            9.841571e-012
J4 Jitter (CHA)            -
J4 Jitter (CHB)            -

```

Figure 6.9.9-5 Result File Example (4)

J4 Jitter (CHC)	-	[Bathtub][CHB]		
J4 Jitter (CHD)	-	Measure Edge Type	ALL	
J9 Jitter (CHA)	-	Total Samples	-	
J9 Jitter (CHB)	-			
J9 Jitter (CHC)	-	[Bathtub][CHC]		
J9 Jitter (CHD)	1.705248e-011	Measure Edge Type	ALL	
		Total Samples	-	
[TJ Histogram][CHA]				
Total Samples	-	[Bathtub][CHD]		
		Measure Edge	ALL	
[TJ Histogram][CHB]		Total Samples	65200	
Total Samples	-	Unit Interval	BER(Estimate)	BER(Actual)
		0.000000e+000	2.500797e-001	2.629325e-001
[TJ Histogram][CHC]		3.878785e-010	2.363070e-001	2.199969e-001
Total Samples	-	7.757569e-010	2.187477e-001	1.760318e-001
		1.163635e-009	1.946739e-001	1.231880e-001
[TJ Histogram][CHD]		1.551514e-009	1.636975e-001	8.758698e-002
Total Samples	465200	1.939392e-009	1.281193e-001	6.095059e-002
Edge Deviation	Number Hits	2.327271e-009	9.216683e-002	3.583689e-002
-7.253327e-009	0	2.715149e-009	6.032596e-002	2.320497e-002
-7.238821e-009	0	3.103028e-009	3.563668e-002	1.473366e-002
-7.224314e-009	0	3.490906e-009	1.888023e-002	6.455358e-003
:		3.878785e-009	8.229616e-003	3.710222e-003
:		4.266663e-009	3.418210e-003	1.479800e-003
7.224314e-009	0	4.654542e-009	1.258116e-003	6.433911e-004
7.238821e-009	0	5.042420e-009	4.094003e-004	2.144637e-004
		:		
		:		
[Bathtub][CHA]		3.801209e-008	2.347806e-001	1.967705e-001
Measure Edge Type	ALL	3.839997e-008	2.487629e-001	2.359101e-001
Total Samples	-			

Figure 6.9.9-6 Result File Example (5)

Chapter 7 Performance Test

This chapter describes how to test the performance of the MP2110A.

7.1	Performance Test for Pulse Pattern Generator	7-2
7.1.1	Required Equipment.....	7-2
7.1.2	Frequency Accuracy.....	7-3
7.1.3	Waveform	7-4
7.1.4	Skew	7-9
7.2	Performance Test for Error Detector	7-12
7.2.1	Required Equipment.....	7-12
7.2.2	Operating Frequency.....	7-13
7.2.3	Rx Sensitivity	7-17
7.2.4	Maximum Input Level and Patterns.....	7-19
7.2.5	Error Detection	7-21
7.3	Performance Test for Sampling Oscilloscope	7-23
7.3.1	Required Equipment.....	7-24
7.3.2	Amplitude Accuracy.....	7-26
7.3.3	Optical Power Meter	7-30
7.3.4	CRU (MP2110A-x54).....	7-37
7.3.5	26G/53G CRU (MP2110A-x55).....	7-43

7.1 Performance Test for Pulse Pattern Generator

This section describes the performance test items for the pulse pattern generator.

- Operation frequency range
- Frequency accuracy



CAUTION

Connect a 50 Ω terminator to unused input/output connectors.

7.1.1 Required Equipment

The following table shows the equipment required for the performance test.

Before starting performance tests, warm up the MP2110A and the measuring instruments for at least 1 hour.

Table 7.1.1-1 Equipment for Performance Test

Product Name	Required Performance	Recommended Equipment
Sampling oscilloscope	Electrical interface Bandwidth: 40 GHz or more	MP2110A (Anritsu)
Frequency counter	Frequency range: 500 MHz to 20 GHz Accuracy: 0.1 ppm max.	MF2412C (Anritsu)

7.1.2 Frequency Accuracy

- (1) Specification
 - ±10 ppm (One hour after power on)
- (2) Setup

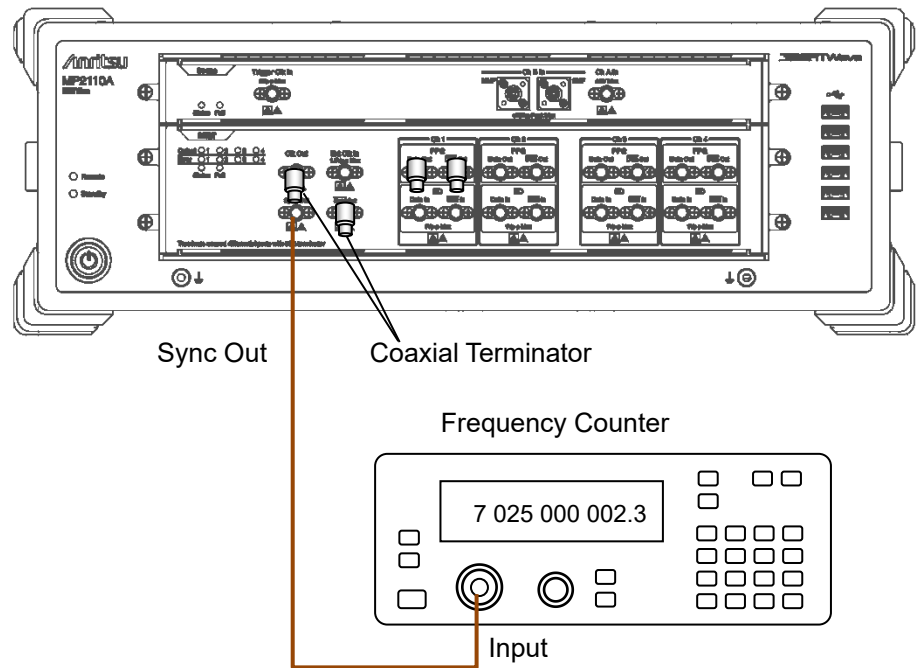

Figure 7.1.2-1 Operation Frequency Range Test Setup

- (3) Procedure
 1. Connect the **Sync Out** connector to the input connector of the frequency counter.
 2. Connect coaxial terminators to **Sync Out** connector.
 3. Click **PPG/ED Ch1**. Configure the settings as shown below:

Item	Setting Value
Reference Clock	Internal
Bit Rate	Variable 28 200 000 kbit/s 0 ppm
Sync Output	PPG_1/8 Clk
Test Pattern (PPG)	PRBS 2 ³¹ -1, POS

4. Read the setting value of the frequency counter.
5. Check that the read value multiplied by 4 is within the following range.
3 525 000 ±35.25 kHz
6. Set Bit Rate to 24 300 000 kbit/s.
When the MP2110A-x93 is installed, input 9 500 000 kbit/s.

7. Read the value measured by the frequency counter.
8. Check that the read value is within the following limited values.
 Without the MP2110A-x93: 3 037 500±30.37 kHz
 With the MP2110A-x93: 1 187 500±11.87 kHz

7.1.3 Waveform

(1) Specification

- Amplitude: 0.1 to 0.8 Vp-p
- Accuracy: (±20% of setting) ±20 mV
- Data Crossing: 50±10%
 (Amplitude: 0.3 Vp-p, Bit rate: 25.78125 Gbit/s)
- Rise/fall time: 17 ps
 (Amplitude: 0.3 Vp-p, Percentage: 20-80%, Bit rate: 25.78125 Gbit/s)
- Jitter (RMS): 0.9 ps (Amplitude 0.3 Vp-p, 25.78125 Gbit/s)

(2) Setup

Figure 7.1.3-1 and Figure 7.1.3-2 show the connection diagrams when performing the test using one MP2110A.

Figure 7.1.3-3 and Figure 7.1.3-4 show the connection diagrams when performing the test using two MP2110As (one MP2110A is used as the sampling oscilloscope).

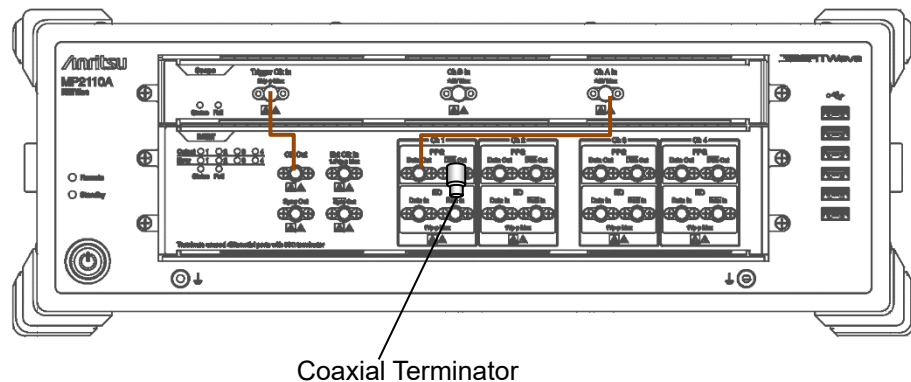

Figure 7.1.3-1 PPG1 Data Out Waveform Test Connection Diagram

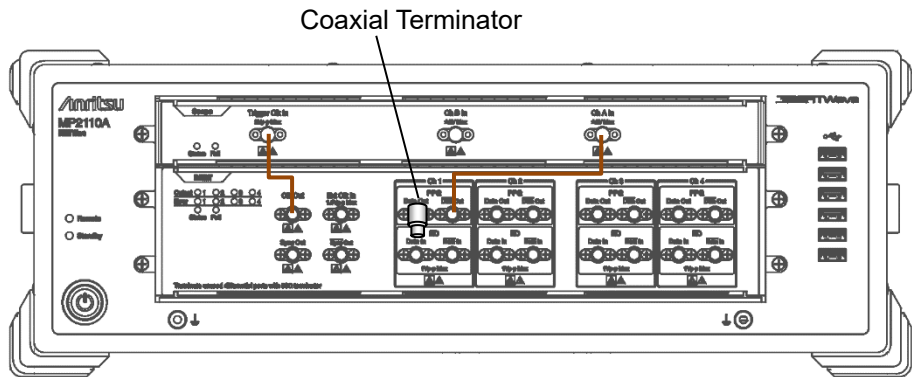

Figure 7.1.3-2 PPG1 Data Out Waveform Test Connection Diagram

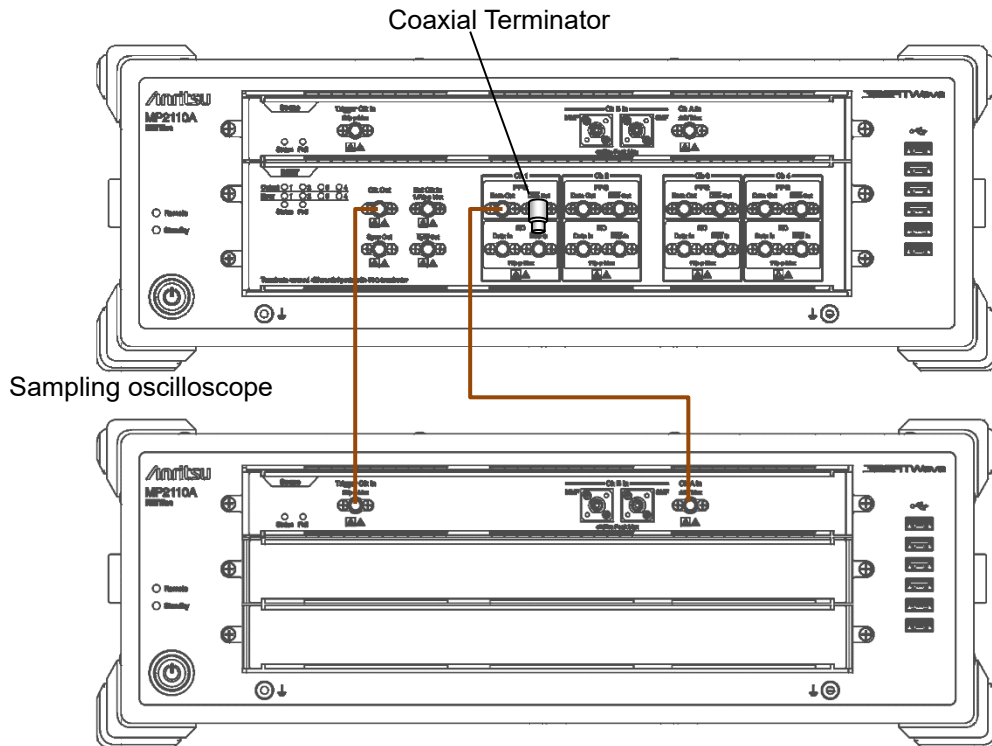

Figure 7.1.3-3 PPG1 Data Out Waveform Test Connection Diagram

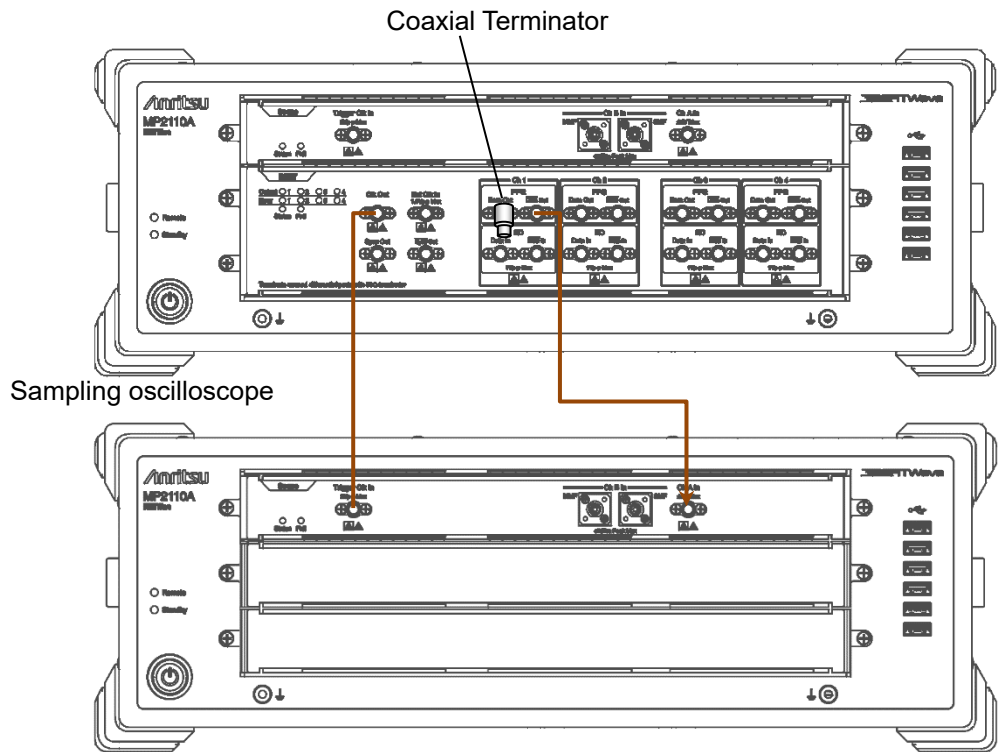

Figure 7.1.3-4 PPG1 Data Out Waveform Test Connection Diagram

(3) Procedure

1. Connect the coaxial terminator to the **PPG1 Data Out** connector.
2. Connect the **Clk Out** connector and the **Trigger Clk In** connector of the sampling oscilloscope using a coaxial cable.
3. Connect the **PPG1 Data Out** connector and the **Ch A In** connector of the sampling oscilloscope using a coaxial cable.
4. Click **PPG/ED Ch1**. Configure the settings as shown below:

Item	Setting Value
Reference Clock	Internal
Bit Rate	100GbE/4 (25.78125G), 0 ppm
Clock Output	Ch1/2
PPG Amplitude	0.1
External ATT	0
Test Pattern (PPG)	PRBS 2 ³¹ -1, POS
PPG Data/XData	ON

5. Click **Scope**. Configure the settings as shown below:

Dialog Box	Item	Setting Value
Setup	Signal Type	NRZ
	Sampling Mode	Eye
	Number of Samples	4050
	Accumulation Time	Persistency
	Time	10.0 sec
Amplitude	Scale	100 mV/Div
	Offset	0 mV
Time	Tracking	Symbol Rate: PPG, Divide Ratio: Clock Output*
Measure - Amplitude/Time	Display	On
	Item	(A) Eye Amplitude
	Rise/Fall Time	20/80%

*: Set it to Off when using two MP2110As (Figure 7.1.3-3 and Figure 7.1.3-4), and input Divide Ratio.

6. Click **Ch A**, **Sampling Hold**, and **Auto Scale** of Scope, and measure the eye amplitude.
7. Click **PPG/ED Ch1**.
8. Set Amplitude to 0.8 Vp-p.
9. Click **Scope**. Measure the EYE amplitude on the sampling oscilloscope.

10. Click **PPG/ED Ch1**.
11. Set Amplitude to 0.3 Vp-p.
12. Click **Scope**. Configure the settings as shown below:

Dialog Box	Item	Setting Value
Measure - Amplitude/Time	Item	(A) Fall Time
		(A) Rise Time
		(A) Crossing
		(A) Jitter RMS

13. Measure the amplitude, rise/fall time, and Data Crossing on the sampling oscilloscope.
14. Connect the coaxial terminator to the **PPG1 Data Out** connector. (Refer to Figure 7.1.3-4.)
15. Connect the **PPG1 Data Out** connector to the **Ch A In** connector of the sampling oscilloscope.
16. Repeat steps 4 to 13.

For PPG2 to PPG4, perform tests in the same way. For PPG3 and PPG4 test, change the Clock Output in step 4 to the following value.

Item	Setting Value
Clock Output	Ch3/4

7.1.4 Skew

- (1) Specification
 - ±8 ps (Amplitude 0.3 V_{p-p}, 25.78125 Gbit/s)
- (2) Setup

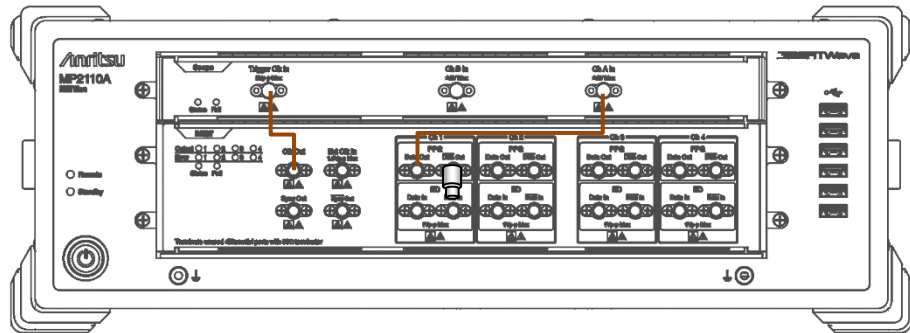

Figure 7.1.4-1 PPG1 Data Out Skew Test Connection Diagram

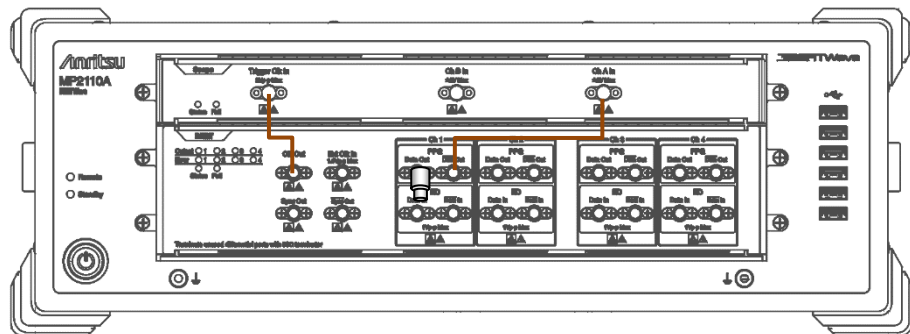

Figure 7.1.4-2 PPG1 Data Out Skew Test Connection Diagram

- (3) Procedure
 1. Connect the **Clk Out** connector and the **Trigger Clk In** connector of the sampling oscilloscope using a coaxial cable.
 2. Connect the **PPG1 Data Out** connector and the **Ch A In** connector of the sampling oscilloscope using a coaxial cable.
 3. Connect the coaxial terminator to the **PPG1 Data Out** connector. (refer to Figure 7.1.4-1).

4. Click **PPG/ED Ch1**. Configure the settings as shown below:

Item	Setting Value
Reference Clock	Internal
Bit Rate	100GbE/4 (25.78125G), 0 ppm
Clock Output	Ch1/2
PPG Amplitude	0.3 Vp-p
External ATT	0 dB
Test Pattern (PPG)	PRBS 2 ⁹⁻¹ , POS
PPG Data/XData	ON

5. Click **Scope**. Configure the settings as shown below:

Dialog Box	Item	Setting Value
Setup	Signal Type	NRZ
	Sampling Mode	Eye
	Number of Samples	4050
	Accumulation Time	Persistency
	Time	10.0 sec

6. Display the X1 marker by clicking **Marker** of Scope, and move the X1 marker to the left cross-point.
7. Connect the coaxial terminator to the **PPG1 Data Out** connector.
8. Connect the **PPG1 Data Out** connector to the **Ch A In** connector of the sampling oscilloscope. (refer to Figure 7.1.4-2).
9. Display the X2 marker by clicking **Marker** of Scope, and move the X2 marker to the left cross-point.
10. When the time unit is **UI**, change Unit in the **Scale/Offset** tab to **Time** by clicking **Time** of Scope.
11. Measure the time lag of two waveforms using the X1 and X2 markers. Note that the polarities of two waveforms are inverted.

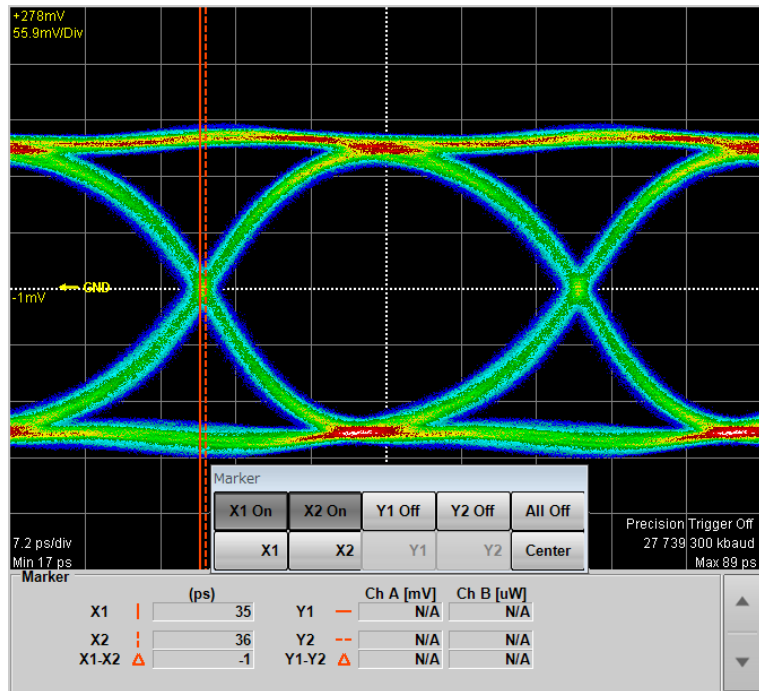

Figure 7.1.4-3 Measurement Example of Skew

For PPG2 to PPG4, perform a test in the same way. For PPG3 and PPG4 test, change the Clock Output in step 4 to the following value.

Item	Setting Value
Clock Output	Ch3/4

7.2 Performance Test for Error Detector

This section describes the performance test items for the error detector.

- Operating Frequency
- Rx Sensitivity
- Maximum Input Level and Patterns
- Error Detection

Before testing the performance of the ED, confirm that the performance of the tested pulse pattern generator satisfies the specifications.

7.2.1 Required Equipment

The following table shows the equipment required for the performance test.

Before starting performance tests, warm up the MP2110A and the measuring instruments for at least 1 hour.

Table 7.2.1-1 Equipment for Performance Test

Product Name	Required Performance	Recommended Equipment
Sampling oscilloscope	Electrical interface Bandwidth: 40 GHz or more	MP2110A (Anritsu)
Fixed attenuator	20 dB, K connector Bandwidth: DC to 40 GHz	41KC-20 (Anritsu)

7.2.2 Operating Frequency

(1) Specification

Without MP2110A-x93:

24.3 Gbit/s -100 ppm to 28.2 Gbit/s +100 ppm

With MP2110A-x93:

24.3 Gbit/s -100 ppm to 28.2 Gbit/s +100 ppm,

9.5 Gbit/s -100 ppm to 14.2 Gbit/s +100 ppm

BER 10^{-12} or less under the following conditions:

- Amplitude: 0.05 Vp-p
- Pattern: PRBS2³¹-1
- Mark ratio: 50%
- Single-end
- Back-to-back connection

(2) Setup

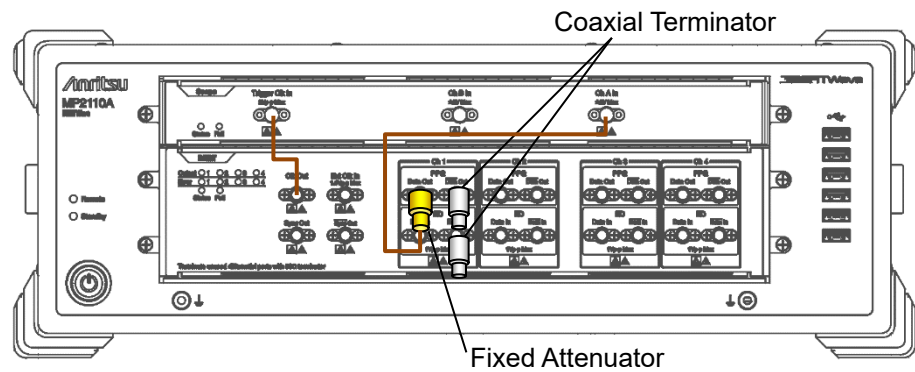

(a) Amplitude Check

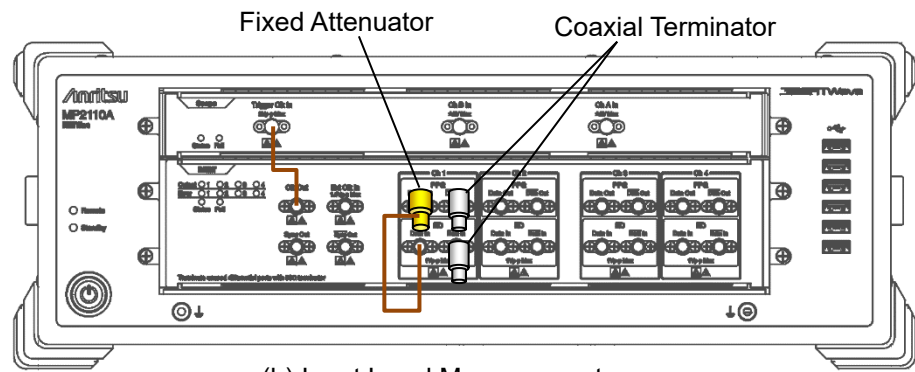

(b) Input Level Measurement

Figure 7.2.2-1 ED1 Data In Input Sensitivity Test Connection Diagram

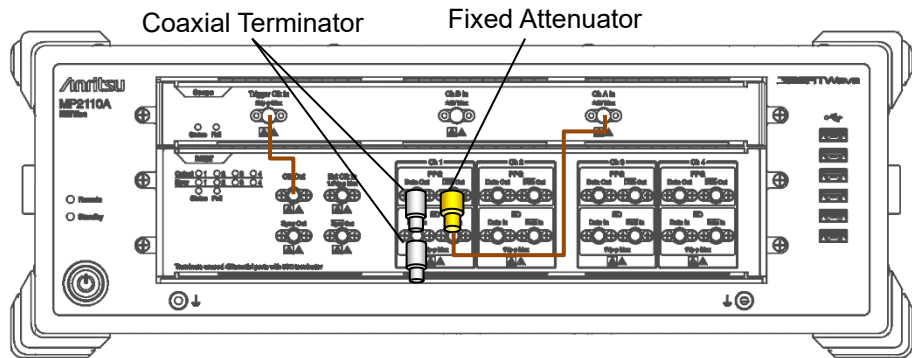

(a) Amplitude Check

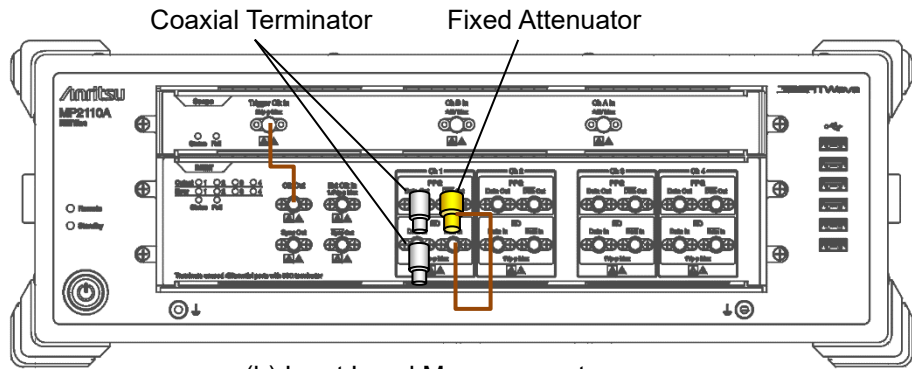

(b) Input Level Measurement

Figure 7.2.2-2 ED1 Data In Input Sensitivity Test Connection Diagram

(3) Procedure

1. Connect the **Clk Out** connector and the **Trigger Clk In** connector of the sampling oscilloscope using a coaxial cable.
2. Connect the coaxial terminator to the **ED1 Data In** connector and **PPG1 Data Out** connector.
3. Attach a 20 dB fixed attenuator to the **PPG1 Data Out** connector. (Refer to (a) in Figure 7.2.2-1.)
4. Connect the 20 dB fixed attenuator and **Ch A In** connector using a coaxial cable.
5. Click **PPG/ED Ch1**. Configure the settings as shown below:

Item	Setting Value
Reference Clock	Internal
Bit Rate	When MP2110A-x93 is not installed: 24 300 000 kbit/s, -100 ppm When MP2110A-x93 is installed: 9 500 000 kbit/s, -100 ppm
Clock Output	Ch1/2
PPG Amplitude	0.5
External ATT	0
Test Pattern (PPG)	PRBS 2 ³¹ -1, POS
Test Pattern (ED)	PRBS 2 ³¹ -1, POS
ED Input Condition	Single-Ended Data
Threshold	0 mV
PPG Data/XData	ON
Gating Cycle	Single
Gating Period	45 s

6. Click **Scope**. Configure the settings as shown below:

Dialog Box	Item	Setting Value
Setup	Signal Type	NRZ
	Sampling Mode	Eye
	Number of Samples	4050
	Accumulation Time	Persistency
	Time	10.0 sec
Time	Tracking	Symbol Rate: PPG, Divide Ratio: Clock Output
Measure - Amplitude/Time	Display	On
	Item Selection	(Ch A) Eye Amplitude

7. In the Scope window, click **Ch A** to measure the amplitude.
8. Adjust the PPG1 Amplitude so that the Scope amplitude is 50±1 mV.

9. Connect the 20 dB fixed attenuator and **ED1 Data In** connector using a coaxial cable. (Refer to (b) in Figure 7.2.2-1.)
10. Click **Start** at All Measurements.
11. Record the error rate ER for the ED Result after measurement is complete.
12. Connect the 20 dB fixed attenuator and **Ch A In** connector using a coaxial cable.
13. Click **PPG/ED Ch1**. Change Bit Rate to following value.
28200000 kbit/s, 100 ppm
14. Repeat steps 7 to 11.
15. Connect coaxial terminators to the **PPG1 Data Out** and **ED1 Data In** connectors. (Refer to (a) in Figure 7.2.2-2.)
16. Attach the 20 dB fixed attenuator to the **PPG1 Data Out** connector.
17. Connect the 20 dB fixed attenuator and **Ch A In** connector using a coaxial cable.
18. Repeat steps 7 and 8.
19. Connect the 20 dB fixed attenuator and **ED1 Data In** connector using a coaxial cable. (Refer to (b) in Figure 7.2.2-2.)
20. Click **PPG/ED Ch1**.
21. Set Data Input Condition to **Single-Ended XData**.
22. Repeat steps 10 and 11.
23. Click **PPG/ED Ch1**. Change Bit Rate to following value.
When MP2110A-x93 is not installed: 24300000 kbit/s, -100 ppm
When MP2110A-x93 is installed: 9500000 kbit/s, -100 ppm
24. Connect the 20 dB fixed attenuator and **Ch A In** connector using a coaxial cable.
25. Repeat steps 7 and 8.
26. Connect the 20 dB fixed attenuator and **ED1 Data In** connector using a coaxial cable. (Refer to (b) in Figure 7.2.2-2.)
27. Repeat steps 10 and 11.

For ED2 to ED4, perform tests in the same way. For ED3 and ED4 test, change the Clock Output in step 4 to the following value.

Item	Setting Value
Clock Output	Ch3/4

7.2.3 Rx Sensitivity

(1) Specification

40 mVp-p

BER 10^{-12} or less under the following conditions:

- Bit rate: 25.78125 Gbit/s
- Pattern: PRBS31
- Mark ratio: 50%
- Single-end
- Back-to-back connection

(2) Setup

Same as Figure 7.2.2-1 and Figure 7.2.2-2.

(3) Procedure

1. Connect the **Clk Out** connector and the **Trigger Clk In** connector of the sampling oscilloscope using a coaxial cable.
2. Connect the coaxial terminators to the **PPG1 Data Out** and **ED1 Data In** connectors.
3. Attach a 20 dB fixed attenuator to the **PPG1 Data Out** connector. (Refer to (a) in Figure 7.2.2-1.)
4. Connect the 20 dB fixed attenuator and **Ch A In** connector using a coaxial cable.
5. Click **PPG/ED Ch1**. Configure the settings as shown below:

Item	Setting Value
Reference Clock	Internal
Symbol Rate	100GbE/4 (25.78125G), 0 ppm
Clock Output	Ch1/2
PPG Amplitude	0.4
External ATT	0
Test Pattern (PPG)	PRBS $2^{31}-1$, POS
Test Pattern (ED)	PRBS $2^{31}-1$, POS
ED Input Condition	Single-Ended Data
Threshold	0 mV
PPG Data/XData	ON
Gating Cycle	Single
Gating Period	45 s

- Click **Scope**. Configure the settings as shown below:

Dialog Box	Item	Setting Value
Setup	Signal Type	NRZ
	Sampling Mode	Eye
	Number of Samples	4050
	Accumulation Time	Persistency
	Time	10.0 sec
Time	Tracking	Bit Rate: PPG, Divide Ratio: Clock Output
Measure - Amplitude/Time	Display	On
	Item	(Ch A) Eye Amplitude

- In the Scope window, click **Ch A** to measure the amplitude.
- Adjust the PPG1 Amplitude so that the Scope EYE amplitude is 40 ± 1 mV.
- Connect the 20 dB fixed attenuator and **ED1 Data In** connector using a coaxial cable. (Refer to (b) in Figure 7.2.2-1.)
- Click **Start** at All Measurements.
- Record the error rate ER for the ED Result after measurement is complete.
- Connect coaxial terminators to the **PPG1 Data Out** and **ED1 Data In** connectors. (Refer to (a) in Figure 7.2.2-2.)
- Attach the 20 dB fixed attenuator to the **PPG1 Data Out** connector.
- Connect the 20 dB fixed attenuator and **Ch A In** connector using a coaxial cable.
- Repeat steps 7 and 8.
- Connect the 20 dB fixed attenuator and **ED1 Data In** connector using a coaxial cable. (Refer to (b) in Figure 7.2.2-2.)
- Click **PPG/ED Ch1**.
- Set ED Input Condition to **Single-Ended XData**.
- Repeat steps 10 and 11.

For ED2 to ED4, perform tests in the same way. For ED3 and ED4 test, change the Clock Output in step 4 to the following value.

Item	Setting Value
Clock Output	Ch3/4

7.2.4 Maximum Input Level and Patterns

(1) Specification

800 mVp-p

BER 10^{-12} or less under the following conditions:

- Bit rate:
 - When MP2110A-x93 is not installed: 24.3 to 28.2 Gbit/s
 - When MP2110A-x93 is installed: 9.5 to 28.2 Gbit/s
- Pattern: PRBS31, PRBS23, PRBS15, PRBS9, PRBS7
- Mark ratio: 50%
- Single-end
- Back-to-back connection

(2) Setup

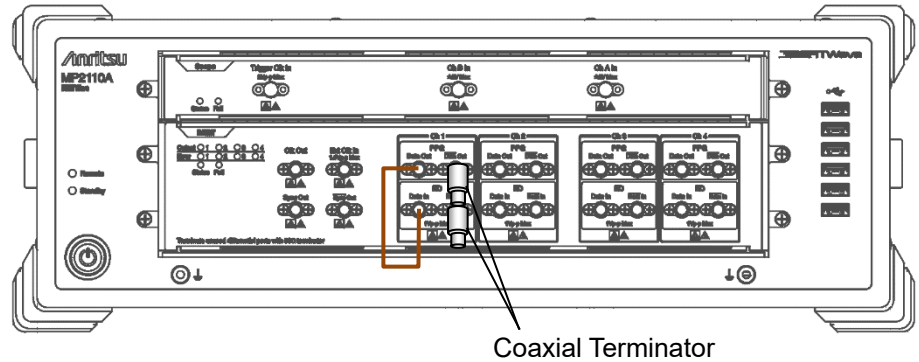

Figure 7.2.4-1 ED1 Data In Pattern Test Connection Diagram

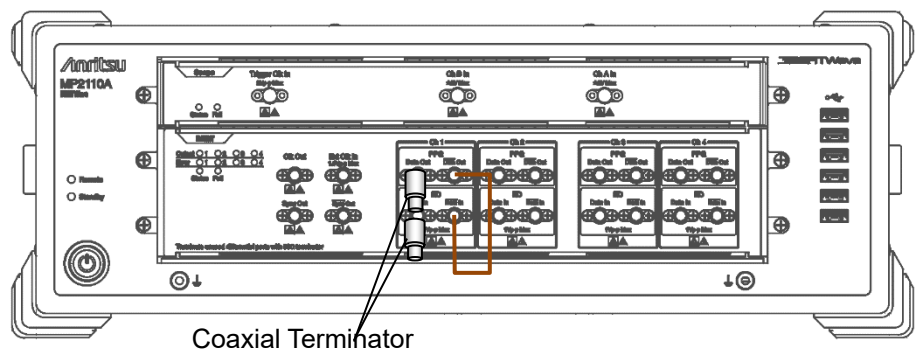

Figure 7.2.4-2 ED1 Data In Pattern Test Connection Diagram

(3) Procedure

1. Connect coaxial terminators to the **PPG1 Data Out** and **ED1 Data In** connectors. (Refer to Figure 7.2.4-1.)
2. Connect the **PPG1 Data Out** and **ED1 Data In** connectors using a coaxial cable.

- Click **PPG/ED Ch1**. Configure the settings as shown below:

Item	Setting Value
Reference Clock	Internal
Symbol Rate	100GbE/4 (25.78125G), 0 ppm
Clock Output	Ch1/2
PPG Amplitude	0.8
External ATT	0
Test Pattern (PPG)	PRBS 2 ³¹ -1, POS
Test Pattern (ED)	PRBS 2 ³¹ -1, POS
ED Input Condition	Single-Ended Data
Threshold	0 mV
PPG Data/XData	ON
Gating Cycle	Single
Gating Period	45 s (28.2 Gbit/s or 24.3 Gbit/s) 120 s (9.5 Gbit/s)

- Click **Start** at All Measurements.
- After measurement, confirm that the error count of the ED Result is 0.
- Change Test Pattern for (PPG) and (ED) in succession to **PRBS 2⁷-1**, **PRBS 2⁹-1**, **PRBS 2¹⁵-1**, and **PRBS 2²³-1**, and repeat steps 4 and 5 each time.
- Connect coaxial terminators to the **PPG1 Data Out** and **ED1 Data In** connectors. (Refer to Figure 7.2.4-2.)
- Connect the **PPG1 Data Out** and **ED1 Data In** connectors using a coaxial cable.
- Click **PPG/ED Ch1** and set ED Input condition to **Single-Ended XData**.
- Repeat steps 3 to 6.
- Change the Bitrate to the following value,

When MP2110A-x93 is not installed:	24.3 Gbit/s
When MP2110A-x93 is installed:	9.5 Gbit/s
- Repeat steps 1 to 10.

For ED2 to ED4, perform tests in the same way. For ED3 and ED4 test, change the Clock Output in step 3 to the following value.

Item	Setting Value
Clock Output	Ch3/4

7.2.5 Error Detection

(1) Specification

Error detection is possible under the following conditions:

- Amplitude: 50 mV
- Bit rate: 25.78125 Gbit/s
- Pattern: PRBS31
- Mark ratio: 50%
- Single-end
- Back-to-back connection

(2) Setup

Same as Figure 7.2.2-1 and Figure 7.2.2-2.

(3) Procedure

1. Connect the **Clk Out** connector and the **Trigger Clk In** connector of the sampling oscilloscope using a coaxial cable.
2. Connect the coaxial terminators to the **ED1 Data In** connector, and **PPG1 Data Out** connector.
3. Attach a 20 dB fixed attenuator to the **PPG1 Data Out** connector. (Refer to (a) in Figure 7.2.2-1.)
4. Connect the 20 dB fixed attenuator and **Ch A In** connector using a coaxial cable.
5. Click **PPG/ED Ch1**. Configure the settings as shown below:

Item	Setting Value
Reference Clock	Internal
Symbol Rate	100GbE/4 (25.78125G), 0 ppm
Clock Output	Ch1/2
PPG Amplitude	0.5
External ATT	0
Test Pattern (PPG)	PRBS 2 ³¹ -1, POS
Test Pattern (ED)	PRBS 2 ³¹ -1, POS
ED Input Condition	Single-Ended Data
Threshold	0 mV
PPG Data/XData	ON
Gating Cycle	Single
Gating Period	45 s

6. Click **Scope**. Configure the settings as shown below:

Dialog Box	Item	Setting Value
Setup	Signal Type	NRZ
	Sampling Mode	Eye
	Number of Samples	4050
	Accumulation Time	Persistency
	Time	10.0 sec
Time	Tracking	Symbol Rate: PPG, Divide Ratio: Sync Output
Measure - Amplitude/Time	Display	On
	Item	(Ch A) Eye Amplitude

7. In the Scope window, click **Ch A** to measure the amplitude.
8. Adjust the PPG Amplitude so that the Scope amplitude is 50 ±1 mV.
9. Connect the 20 dB fixed attenuator and **ED1 Data In** connector using a coaxial cable. (Refer to (b) in Figure 7.2.2-1.)
10. Click **Start** at All Measurements.
11. Click **Insert Error** at **PPG/ED1** once.
12. After measurement, confirm that the error count is 20.
13. Connect coaxial terminators to the **PPG1 Data Out** and **ED1 Data In** connectors. (Refer to (a) in Figure 7.2.2-2.)
14. Attach a 20 dB fixed attenuator to the **PPG1 Data Out** connector.
15. Connect the 20 dB fixed attenuator and **Ch A In** connector using a coaxial cable.
16. Repeat steps 7 and 8.
17. Connect the 20 dB fixed attenuator and **ED1 Data In** connector using a coaxial cable. (Refer to (b) in Figure 7.2.2-2.)
18. Click **PPG/ED Ch1**.
19. Set Data Input Condition to **Single-Ended XData**.
20. Repeat steps 10 to 12.

For ED2 to ED4, perform tests in the same way. For ED3 and ED4 test, change the Clock Output in step 5 to the following value.

Item	Setting Value
Clock Output	Ch3/4

7.3 Performance Test for Sampling Oscilloscope

This section describes the performance test items for the sampling oscilloscope.

- Amplitude Accuracy
- Optical Power Meter
- CRU (MP2110A-x54)
- 26G/53G CRU (MP2110A-x55)

For performance test criteria and how to record results, refer to Appendix D “Performance Test Record Form”.

7.3.1 Required Equipment

The following table shows the equipment required for the performance test.

Before starting performance tests, warm up the MP2110A and measuring instruments for at least 1 hour.

Table 7.3.1-1 Equipment for Performance Test

Product Name	Required Performance	Recommended Equipment
Pulse Pattern Generator or Signal Generator	Clock frequency: 7 GHz Amplitude: 0.5 Vp-p	MP2110A (Anritsu)
DC Power Source* ¹	Power voltage: ±2.5 V Power current: ±50 mA Setting accuracy: 1% or less With current limiting function	2400 (Keithley Instruments)
Light Source* ²	Wavelength: 850, 1310, 1550 nm Output level range: +3 dBm or more Level stability: ±0.05 dB	
Optical Power Meter* ²	Wavelength: 750 to 1700 nm Level range: -40 to +10 dBm (100 nW to 10 mW) Accuracy: 5% Linearity: ±0.05 dB or less	8163B+81623B (Keysight Technologies)
Variable Optical Attenuator* ^{2,*4}	For single-mode fiber: Wavelength: 1200 to 1600 nm Insertion loss: 3 dB or less Attenuation: 0 to 30 dB Resolution: 0.1 dB or less For multi-mode fiber: Wavelength: 800 to 900 nm Insertion loss: 3 dB or less Attenuation: 0 to 30 dB Resolution: 0.1 dB or less	G0350F (Anritsu) G0351F (Anritsu)
Fixed Attenuator* ³	20 dB K connector Bandwidth: DC to 40 GHz	41KC-20 (Anritsu)
Light Source* ⁴	Wavelength: 1310 nm Optical fiber: Single mode Optical Modulation Amplitude (OMA): 0.64 mW (-2 dBm) or more Bit rate: 25.78125 Gbit/s	MT1000A, MU100011A, G0389A (Anritsu)
Sampling oscilloscope* ⁴	Optical interface Bandwidth: 30 GHz or more	MP2110A (Anritsu)

*1: Required for MP2110A-x21, MP2110A-x23, MP2110A-x33, and MP2110A-x43

*2: Required for MP2110A-x22, MP2110A-x23, MP2110A-x25, MP2110A-x26, MP2110A-x30, MP2110A-x32, MP2110A-x33,

7.3 Performance Test for Sampling Oscilloscope

MP2110A-x35, MP2110A-x36, MP2110A-x39, MP2110A-x40,
MP2110A-x42, MP2110A-x45, MP2110A-x46, and MP2110A-x49

*3: Required for MP2110A-x54

*4: Required for MP2110A-x55

7.3.2 Amplitude Accuracy

(1) Specification

(-2%-offset amplitude accuracy) to (+2%+offset amplitude accuracy)

The offset amplitude accuracy after calibration is as shown in the following figure.

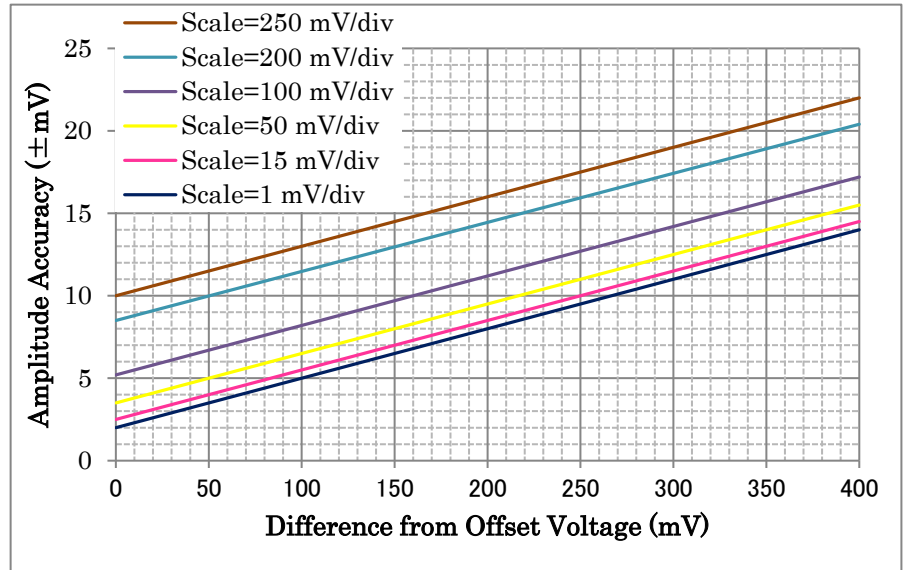

Figure 7.3.2-1 Offset Amplitude Accuracy

(2) Setup

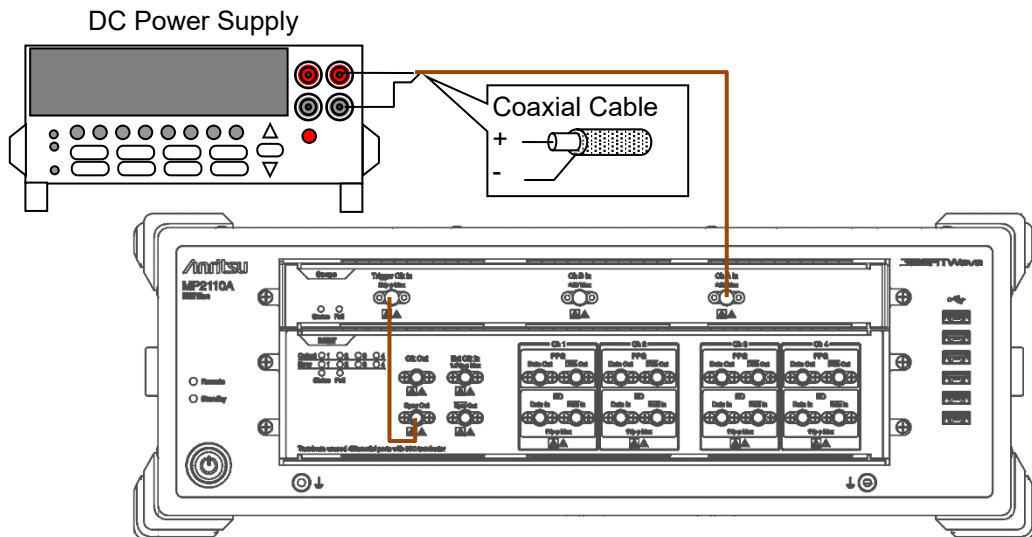

Figure 7.3.2-2 Amplitude Accuracy Test Connection Diagram (When Using a PPG of MP2110A)

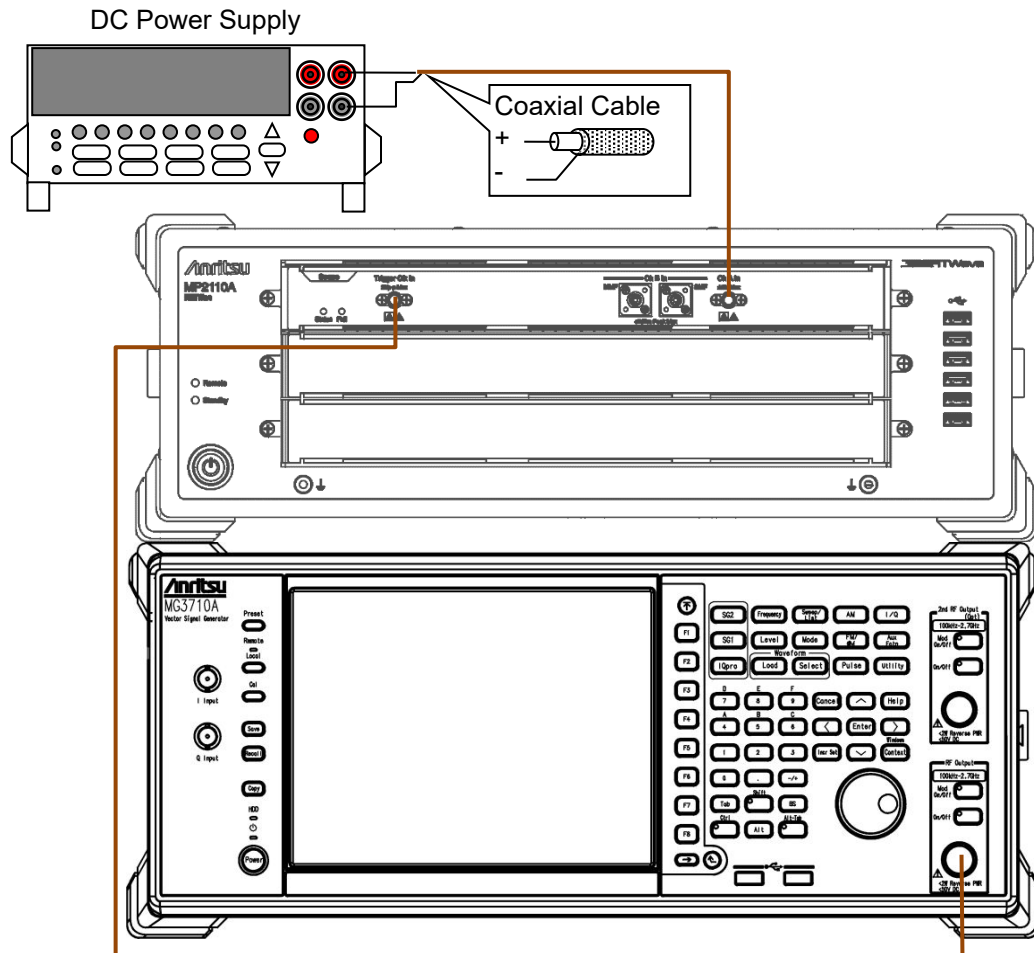

Figure 7.3.2-3 Amplitude Accuracy Test Connection Diagram (When Using a Signal Generator)

(3) Procedure

1. In case of Figure 7.3.2-2, connect the **Sync Out** connector and the **Trigger Clk In** connector using a coaxial cable. In case of Figure 7.3.2-3, connect the **Trigger Clk In** connector and the signal generator **output** connector using a coaxial cable.
2. In case of Figure 7.3.2-2, click **PPG/ED Ch1**. Configure the settings as shown below:

Item	Setting Value
Reference Clock	Internal
Bit Rate	Variable, 28 Gbit/s, 0 ppm
Sync Output	PPG_1/8 Clk

In case of Figure 7.3.2-3, set the signal generator as follows:

- Frequency: 3.5 GHz
 Amplitude: 0.5 V_{p-p} (at sine-wave -2.0 dBm)

- Click **Scope**. Configure the settings as shown below:

Dialog Box	Item	Setting Value
Setup	Signal Type	NRZ
	Sampling Mode	Eye
	Number of Samples	2048
	Accumulation Time	None
Time	Tracking	Off
	Symbol Rate	28 000 000 kbaud
	Divide Ratio	8
	Unit	UI
	UI On Screen	2
	Software Delay	0
Amplitude	Ch A Scale	50 mV/Div.
	Ch A Offset	50 mV
	Ch A Attenuation	0 dB
Histogram	Axis	Amplitude
	X1	0
	X2	2
	Y1	-250 mV
	Y2	250 mV

- Set the Current Limit of DC Power Source to 20 mA.
- Set the DC voltage to 0 V.
- Connect the DC Power Source to **Ch A In** connector.
Connect the center conductor of the coaxial cable to plus terminal and the shield to minus terminal.
- Click **Ch A** to set to On.
- Click **Sampling** to set to Run.
- Record a standard deviation (Std Dev) and an average value (Mean) of the histogram measurement result.
- Set the DC voltage to 200 mV.
- Record the average value of the histogram measurement result.
- Set the DC voltage to -200 mV.
- Record the average value of the histogram measurement result.

With the MP2110A-x21, test the amplitude accuracy for Ch B after measuring the amplitude accuracy for Ch A.

1. Click **Scope**. Configure the settings as shown below:

Dialog Box	Item	Setting Value
Amplitude	Ch B Scale	50 mV/Div.
	Ch B Offset	50 mV
	Ch B Attenuation	0 dB
Histogram	Target Channel	Channel B

2. Set the DC voltage to 0 V.
3. Connect the DC Power Source to **Ch B In** connector.
Connect the center conductor of the coaxial cable to plus and the shield to minus.
4. Click **Ch B** to set to On.
5. Click **Sampling** to set to Run.
6. Record a standard deviation (Std Dev) and an average value (Mean) of the histogram measurement result.
7. Set the DC voltage to 200 mV.
8. Record the average value of the histogram measurement result.
9. Set the DC voltage to -200 mV.
10. Record the average voltage of the histogram measurement result.

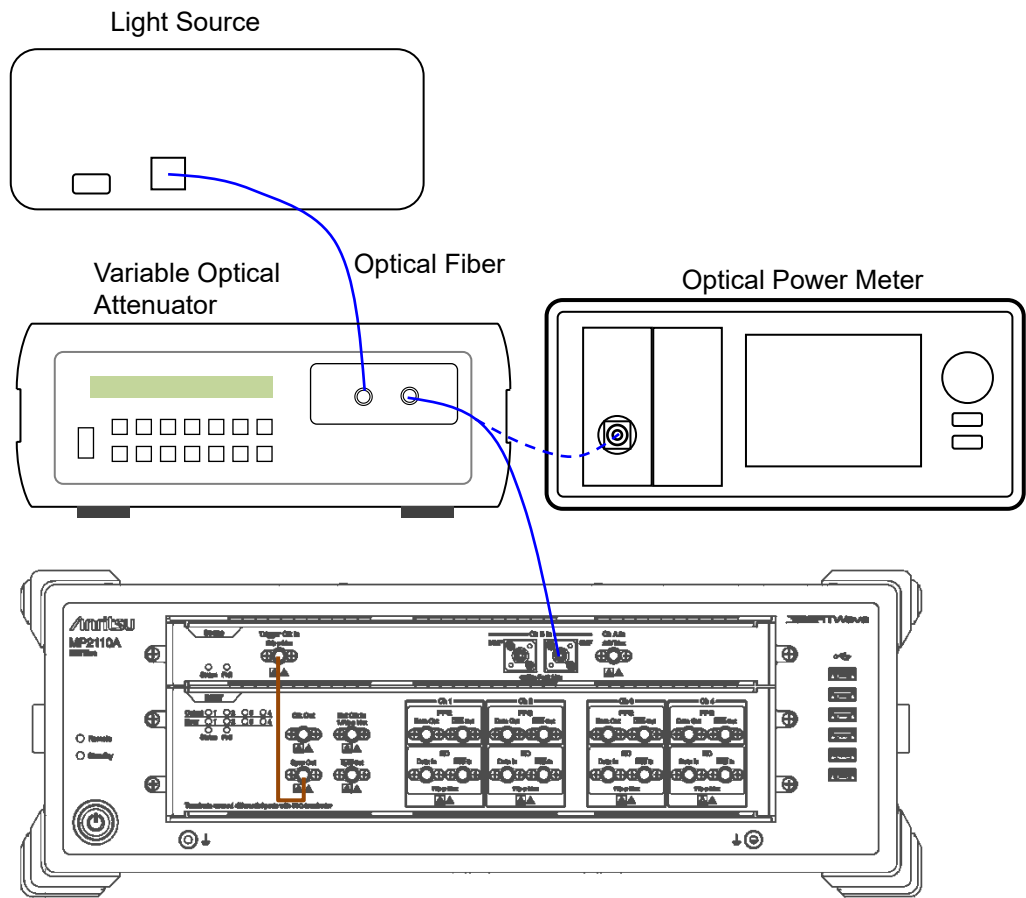

Figure 7.3.3-2 Optical Power Meter Test Connection Diagram (SMF, When Using a PPG of MP2110A)

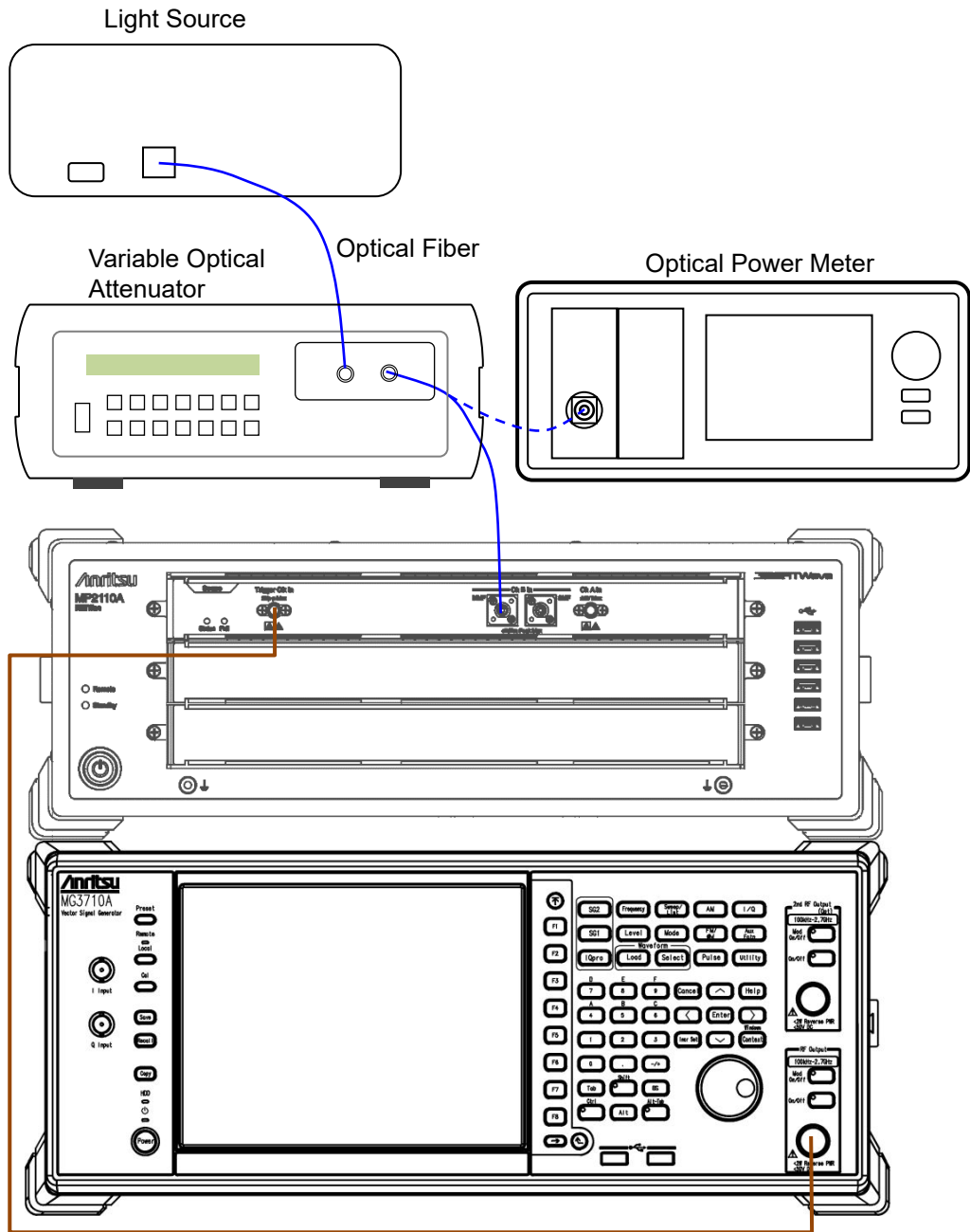

Figure 7.3.3-3 Optical Power Meter Test Connection Diagram (MMF, When Using a Signal Generator)

(3) Procedure

The SMF performance test for Ch B is explained below.

1. Make connection for the **Trigger Clk In** connector as one of the following:
 - In the case of Figure 7.3.3-1, nothing is connected.
 - In the case of Figure 7.3.3-2, connect the **Sync Out** connector and the **Trigger Clk In** connector, using a coaxial cable.
 - In the case of Figure 7.3.3-3, connect the **Output** connector of the signal generator and the **Trigger Clk In** connector, using a coaxial cable.
2. In case of Figure 7.3.3-2, click **PPG/ED Ch1**. Configure the settings as shown below:

Item	Setting Value
Reference Clock	Internal
Bit Rate	Variable, 28 Gbit/s, 0 ppm
Sync Output	PPG_1/8 Clk

In case of Figure 7.3.3-3, set the signal generator as follows:

Frequency: 3.5 GHz

Amplitude: 0.5 Vp-p (at sine-wave -2.0 dBm)

3. Confirm that no light has been input to the optical connector (SMF or MMF) for **Ch B In**.
4. Click **Scope**. Configure the settings as shown below:

Dialog Box	Item	Setting Value
Setup	Signal Type	NRZ
	Sampling Mode	Eye
	Number of Samples	2048
	Accumulation Time	Persistency
	Limit Type	10.0 sec
Time	Tracking	Off
	Divide Ratio	8
	Unit	UI
	UI On Screen	2
	Software Delay	0
Amplitude	Ch B Scale	20 μ W/Div.
	Ch B Offset	60 μ W
	Ch B Attenuation	0 dB
	Input Connector (Wavelength)	SMF 1310 nm
Measure - Amplitude/Time	Display	On
	Item	(Ch B) Average Power (dBm)

5. Click **Calibrate Module** of Amplitude. Click **OK** after completing the calibration.
6. Prepare the variable optical attenuator for single-mode fiber.
7. Connect the output connector of the light source and the input connector of the variable optical attenuator, using a single-mode optical fiber.
8. Connect the output connector of the variable optical attenuator and the optical power meter, using a single-mode optical fiber.
9. Set the light source wavelength to 1310 nm.
10. Set the optical power meter wavelength to 1310 nm.
11. Set the light source output to On.
12. Adjust the variable optical attenuation to set the optical power meter display to around -9 dBm (0.126 mW).
13. Record the optical power meter display P (dBm).
14. Disconnect the optical fiber from the optical power meter and connect it to the optical connector for **SMF of Ch B In**.
15. Click **Scope** to display only Ch B signals on the graph.
16. Click **Sampling** to set to Run.
17. Record the displayed Average Power (dBm).
18. Connect the output connector of the variable optical attenuator and the optical power meter, using a single-mode optical fiber.
19. Set the light source wavelength to 1550 nm.
20. Set the optical power meter wavelength to 1550 nm.
21. Set the Input Connector (Wavelength) to **SMF 1550 nm**.
22. Repeat steps 11 to 17.
23. For MP2110A-x61, prepare the variable optical attenuator and the DFB light source for multi-mode fiber.
24. Connect the output connector of the DFB light source and the input connector of the variable optical attenuator, using a multi-mode optical fiber.
25. Connect the output connector of the variable optical attenuator and the optical power meter, using a multi-mode optical fiber.
26. set the light source wavelength to 850 nm.
27. Set the optical power meter wavelength to 850 nm.
28. Set the Input Connector (Wavelength) to **SMF 850 nm**.
29. Repeat steps 11 to 17.

For the MP2110A-x30 or MP2110A-x40, run the performance test on Ch A, Ch C and Ch D in the same way.

The MMF performance test for Ch B is explained below.

1. Make connection for the **Trigger Clk In** connector as one of the following:
 - In the case of Figure 7.3.3-1, nothing is connected.
 - In the case of Figure 7.3.3-2, connect the **Sync Out** connector and the **Trigger Clk In** connector, using a coaxial cable.
 - In the case of Figure 7.3.3-3, connect the **Output** connector of the signal generator and the **Trigger Clk In** connector, using a coaxial cable.
2. In case of Figure 7.3.3-2, click **PPG/ED Ch1**. Configure the settings as shown below:

Item	Setting Value
Reference Clock	Internal
Bit Rate	Variable, 28 Gbit/s, 0 ppm
Sync Output	PPG_1/8 Clk

In case of Figure 7.3.3-3, set the signal generator as follows:

Frequency: 3.5 GHz

Amplitude: 0.5 Vp-p (at sine-wave -2.0 dBm)

3. Confirm that no light has been input to the optical connector (SMF or MMF) for **Ch B In**.
4. Click **Scope**. Configure the settings as shown below:

Dialog Box	Item	Setting Value
Setup	Signal Type	NRZ
	Sampling Mode	Eye
	Number of Samples	2048
	Accumulation Time	Persistency
	Limit Type	10.0 sec
Time	Tracking	Off
	Divide Ratio	8
	Unit	UI
	UI On Screen	2
	Software Delay	0
Amplitude	Ch B Scale	50 μ W/Div.
	Ch B Offset	150 μ W
	Ch B Attenuation	0 dB
	Input Connector (Wavelength)	MMF 850 nm
Measure - Amplitude/Time	Display	On
	Item	(Ch B) Average Power (dBm)

5. Click **Calibrate Module** of Amplitude. Click **OK** after completing the calibration.

6. Prepare the variable optical attenuator for multimode fiber.
7. Connect the output connector of the light source and the input connector of the variable optical attenuator, using a multi-mode optical fiber.
8. Connect the output connector of the variable optical attenuator and the optical power meter, using a multi-mode optical fiber.
9. Set the light source wavelength to 850 nm.
10. Set the optical power meter wavelength to 850 nm.
11. Set the light source output to On.
12. Adjust the variable optical attenuation to set the optical power meter display to around -5 dBm (0.316 mW).
13. Record the optical power meter display P (dBm).
14. Disconnect the optical fiber from the optical power meter and connect it to the optical connector for **MMF** of **Ch B In**.
15. Click **Scope** to display only Ch B signals on the graph.
16. Click **Sampling** to set to Run.
17. Record the displayed Average Power (dBm).

For the MP2110A-x39 or MP2110A-x49, run the performance test on Ch A, Ch C and Ch D in the same way.

7.3.4 CRU (MP2110A-x54)

(1) Specification

Sensitivity: 20 mVp-p or less

25.78125 Gbit/s, PRBS2³¹-1 NRZ, Loop BW = 10 MHz,
Single-ended, Mark ratio 1/2, Using MP2110A PPG

Additive jitter: 400 fs or less

25.78125 Gbit/s, 26.5625 Gbit/s, 28.05 Gbit/s, Input amplitude
400±100 mVp-p, 1/4Clock Pattern, Loop BW = 10 MHz,
Single-ended, Mark ratio 1/2, Using MP2110A PPG

(2) Setup

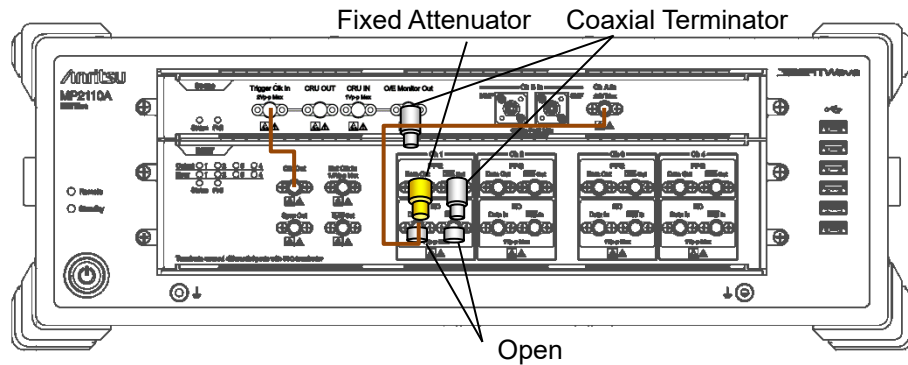

(a) PPG Amplitude Check

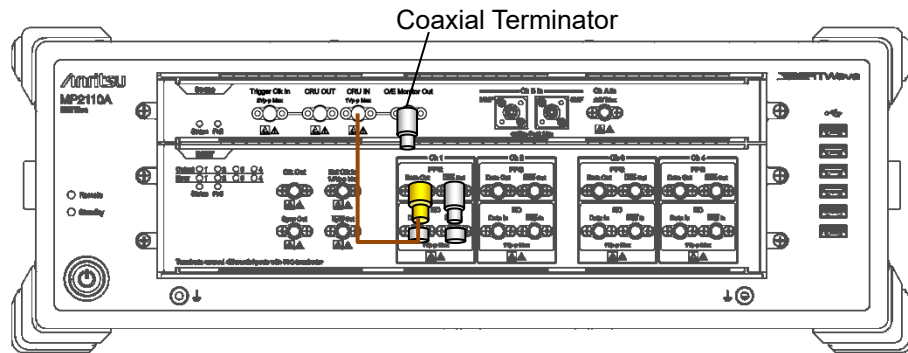

(b) CRU Sensitivity Test

**Figure 7.3.4-1 CRU Sensitivity Test Connection Diagram
(When Using MP2110A's PPG and Electrical Channel Oscilloscope)**

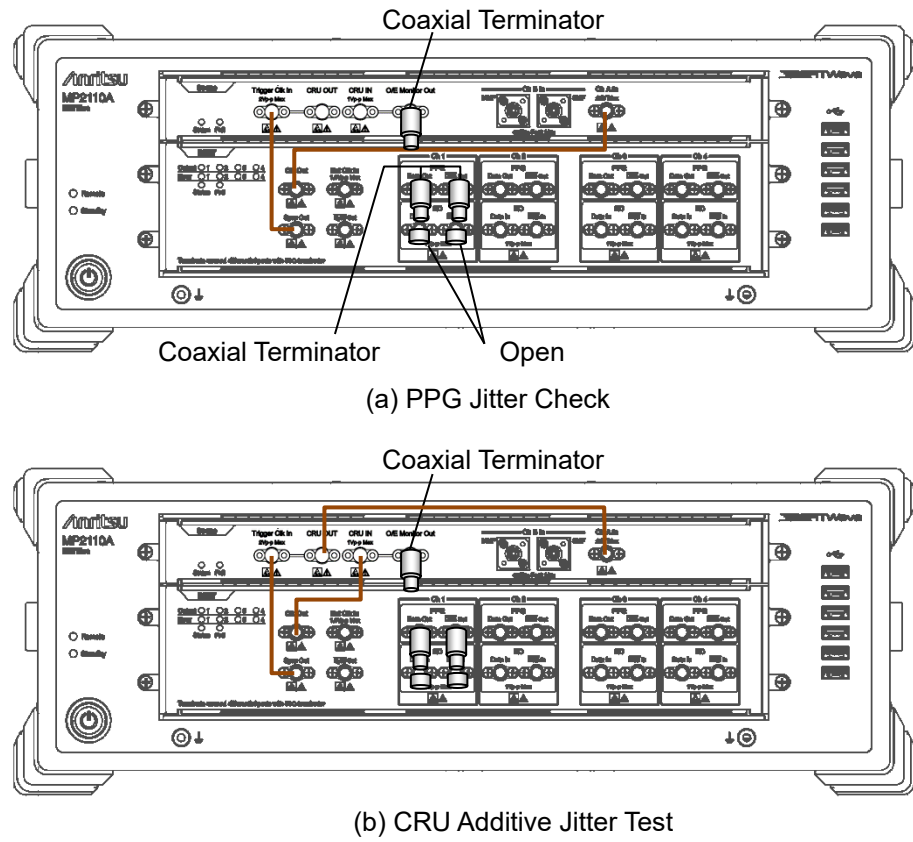

**Figure 7.3.4-2 Additive Jitter Test Connection Diagram
(When Using MP2110A's PPG and Electrical Channel Oscilloscope)**

(3) Procedure

Sensitivity Test: (a) PPG Amplitude Check

1. Connect the **Clk Out** connector and the **Trigger Clk In** connector of the sampling oscilloscope using a coaxial cable.
2. Connect the coaxial terminator to the **PPG1 Data Out** connector and the **O/E Monitor Out** connector of the CRU.
3. Connect an Open connectors to **ED1 Data In** connector, and **ED1 Data In** connector respectively.
4. Connect a 20 dB fixed attenuator to **PPG1 Data Out** connector. Refer to Figure 7.3.4-1 (a).
5. Connect the 20 dB fixed attenuator and **Ch A In** connector using a coaxial cable.
6. Click **PPG/ED Ch1**. Configure the settings as shown below:

Item	Setting Value
Reference Clock	Internal
Bit Rate	25781250 kbit/s
Clock Output	Ch1/2
PPG Amplitude	0.2
External ATT	0
Test Pattern (PPG)	PRBS 2 ³¹ -1, POS
PPG Data/XData	ON

7. Click **Scope**. Configure the settings as shown below:

Dialog Box	Item	Setting Value
Setup	Signal Type	NRZ
	Sampling Mode	Eye
	Number of Samples	4050
	Accumulation Time	Persistency
	Time	10.0 sec
Time - Rate	Tracking	Symbol Rate: PPG, Divide Ratio: Clock Output
Time - CRU	Operation Mode	Recovery
	Operation Rate	100GbE/4 (25.78125G)
	CRU Loop BW	10 MHz

8. Click **Ch A** of Scope and measure the amplitude.
9. Adjust PPG Amplitude to make the eye amplitude on Scope 20±1 mV.
10. Disconnect the coaxial cable that connects the **Clk Out** connector and the **Trigger Clk In** connector.

Sensitivity Test: (b) CRU Sensitivity Test

1. Connect the 20 dB fixed attenuator and **CRU In** connector using the coaxial cable. Make sure that the coaxial terminator is connected to the **OE Monitor Out** connector on the CRU. Refer to Figure 7.3.4-1 (b).
2. Click **Time CRU** of Scope and click the **CRU** tab.
3. Confirm Lock Status turning to Lock in green.

Additive Jitter Test: (a) PPG Jitter Check

1. Remove the 20 dB fixed attenuator from **PPG1 Data Out** connector. Refer to Figure 7.3.4-2 (a).
2. Connect the coaxial terminator to the **PPG1 Data Out** connector and the **O/E Monitor Out** connector of the CRU.
3. Connect the **Sync Out** connector and the **Trigger Clk In** connector using a coaxial cable.
4. Connect the **Clk Out** connector and the **Ch A In** connector o using a coaxial cable.
5. Click **PPG/ED Ch1**. Configure the settings as shown below:

Item	Setting Value
Reference Clock	Internal
Bit Rate	25781250 kbit/s
Sync Out	PPG1_1/8Clk
Clk Out	Ch1/2
Test Pattern (PPG)	PRBS2 ³¹⁻¹
PPG Data/XData	ON

6. Click **Scope**. Configure the settings as shown below:

Dialog Box	Item	Setting Value
Setup	Signal Type	NRZ
	Sampling Mode	Eye
	Number of Samples	4050
	Accumulation Time	Persistency
	Time	10.0 sec
Time - Rate	Tracking	Symbol Rate: PPG, Divide Ratio: UserDefined
	Divide Ratio	4
Time - Scale/Offset	Unit	UI
	UI on Screen	1 UI
Time - CRU	Operation Mode	Recovery
	Operation Rate	100GbE/4 (25.78125G)
	CRU Loop BW	10 MHz
Amplitude	Scale	10.0 mV/Div
	Offset	0 mV
Histogram	Histogram	On
	Axis	Time
	X1	0.00 UI
	X2	1.00 UI
	Y1	1 mV
	Y2	-1 mV

7. Click **Ch A** of Scope to display the graph.
 8. Adjust Software Delay in Time Scale/Offset tab so that the cross point is displayed at center of the window.

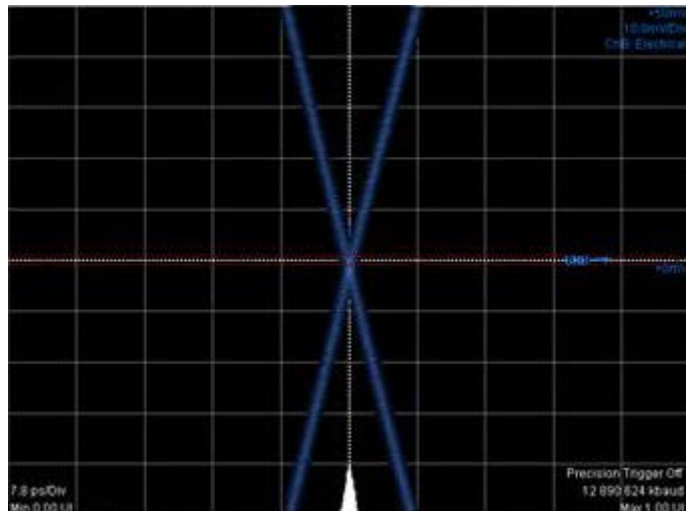

9. Write down the jitter RMS measurement value. The jitter RMS measurement value is the std Dev value for Histogram.

Additive Jitter Test: (b) CRU Additive Jitter Measurement

1. Connect the **Clk Out** connector and the **CRU In** connector using a coaxial cable. Refer to Figure 7.3.4-2 (b).
2. Connect the **CRU Out** connector and the **Ch A In** connector using a coaxial cable. Refer to Figure 7.3.4-2 (b).
3. Click **Time CRU** of Scope and then click **CRU** tab.
4. Confirm Lock Status turning to Lock in Green.
5. Adjust Offset in Time Scale/Offset tab so that the cross point is displayed at center of the window.
6. Write down the jitter RMS measurement value. The jitter RMS measurement value is the std Dev value for Histogram.
7. Calculate the added jitter J_{Add} using the following formula.

$$J_{Add} = \sqrt{(J_{CRU})^2 - (J_{PPG})^2}$$

J_{CRU} : Value measured in step 6.

J_{PPG} : Value measured in step 9 in Additive Jitter Test (a).

8. Change PPG1 Bit Rate and Scope Operation Rate to the following values and repeat steps 4 to 9 in Additive Jitter Test (a) and steps 1 to 7 in Additive Jitter Test (b).

PPG1 Bit Rate	Scope – CRU Operation Rate
26 562 500 kbit/s	400GbE/8 (26.5625G)
28 050 000 kbit/s	32GFC (28.05G)

7.3.5 26G/53G CRU (MP2110A-x55)

(1) Specification

Sensitivity: 265 μW or less (OMA)

25.78125 Gbit/s, PRBS2³¹-1 NRZ, Wavelength 1310 nm

(2) Setup

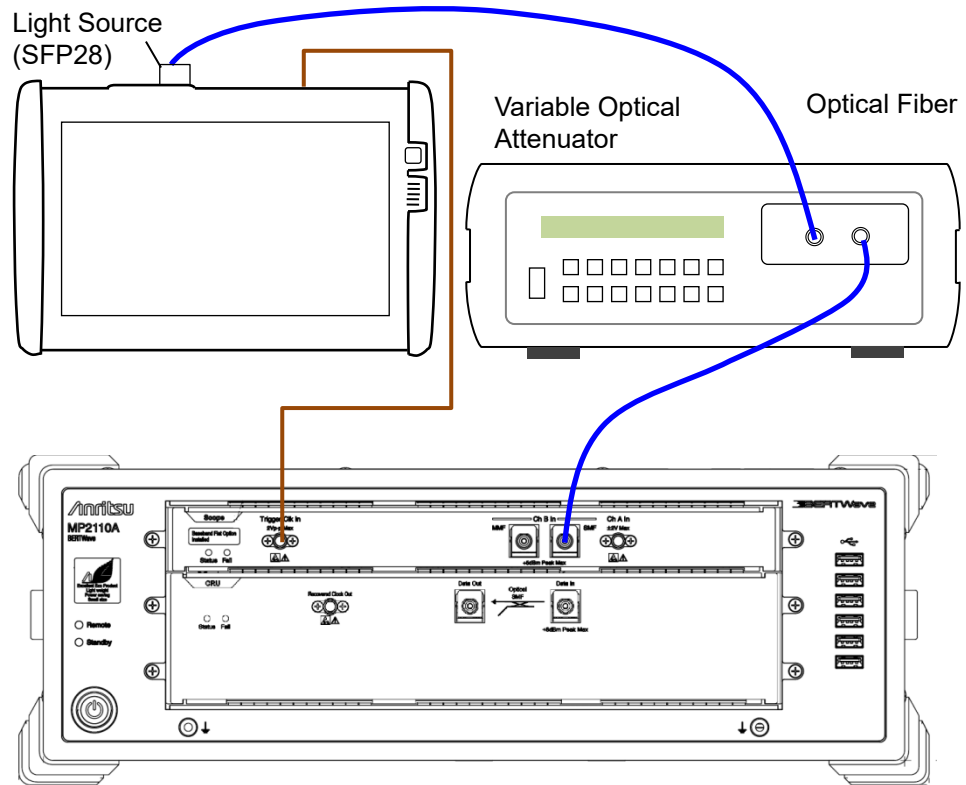

Figure 7.3.5-1 CRU Sensitivity Test Connection Diagram (Optical Modulation Amplitude Check)

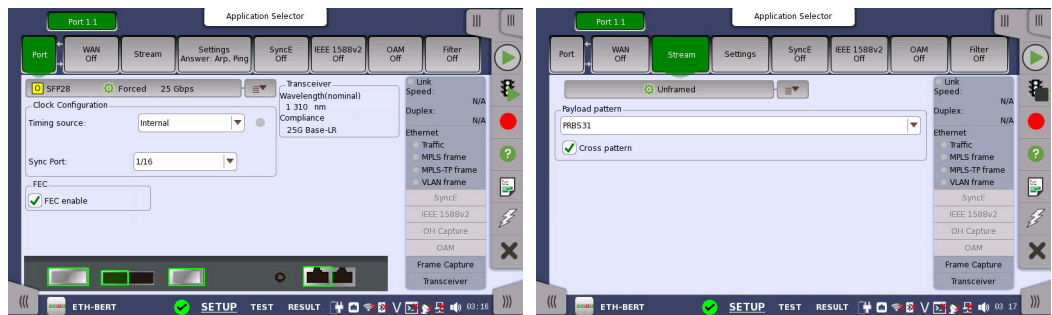

Figure 7.3.5-2 MT1000A Settings

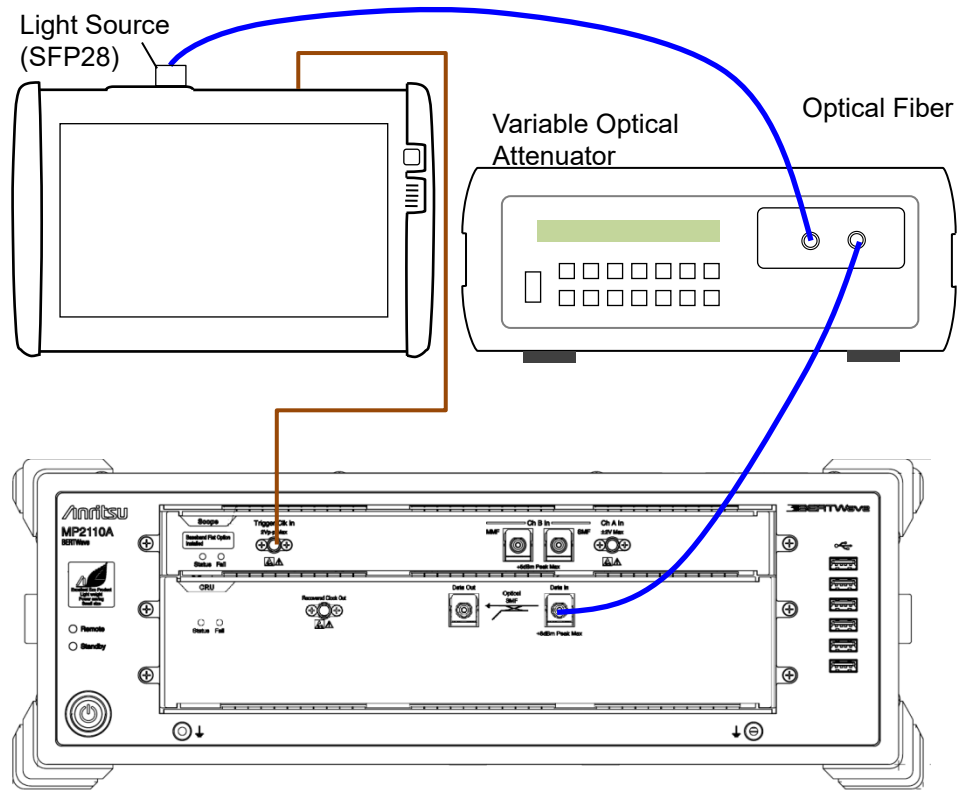

Figure 7.3.5-3 CRU Sensitivity Test Connection Diagram

(3) Procedure

Optical Modulation Amplitude Check

1. Connect the **Sync Clock Out** connector of MU100011A and the **Trigger Clk In** connector of the scope, using a coaxial cable. Refer to Figure 7.3.5-1.
2. Connect the output connector of the light source and the input connector of the variable optical attenuator, using a single-mode optical fiber.
3. Connect the output connector of the variable optical attenuator and the **Ch B In** connector (SMF) of the scope, using a single-mode optical fiber.
4. Configure the settings for MT1000A. Refer to Figure 7.3.5-2.

Item	Setting Value
Application	Ethernet BERT
Port	SFP28
Sync Port	1/16
Stream	Unframed
Payload pattern	PRBS31
Cross pattern	Selected

5. In the MP2110A window, click **Scope**. Configure the settings as shown below:

Dialog Box	Item	Setting Value
Setup - General	Signal Type	NRZ
	Sampling Mode	Eye
	Number of Samples	4050
	Accumulation Time	Persistency
Time - Rate	Tracking	Off
Time - CRU*	Operation Mode	Recovery
	Operation Rate	100GbE/4 (25.78125G)
	CRU Loop BW	4 MHz
	Auto Relock	On

*: When both MP2110A-x54 and MP2110A-x55 are installed, configure the settings on the **CRU(53G)** tab.

6. In the Scope screen, click **Time**, and then on the **Rate** tab, click **Acquire Clock Rate**.
7. Click **Ch B** of Scope and measure the amplitude.

8. Adjust the attenuation of the variable optical attenuator so that the eye amplitude of the scope is $244 \pm 5 \mu\text{W}$.
9. Disconnect the coaxial cable that connects the **Sync Clock Out** connector and the **Trigger Clk In** connector.

CRU Sensitivity Test

1. Connect the output connector of the variable optical attenuator and the **Data In** connector of the 26G/53Gbaud CRU, using a single-mode optical fiber. Refer to Figure 7.3.5-3.
2. Check that the Lock Status indicator turns green (Lock) within 40 seconds.

Chapter 8 Maintenance

This chapter describes maintenance, storage and disposal procedures.

8.1	Daily Maintenance	8-2
8.2	Replacement of Optical Connector.....	8-3
8.3	Optical Connector/Optical Adapter Cleaning.....	8-5
8.4	Displaying Software Version.....	8-8
8.5	Updating Software	8-9
8.6	Adding an Option License.....	8-10
	8.6.1 When adding the MP2110A-39x license	8-10
	8.6.2 When adding other license than MP2110A-39x.....	8-12
8.7	Initializing Corrected Data.....	8-14
8.8	System Recovery Function.....	8-15
	8.8.1 For WES7	8-15
	8.8.2 For Win10	8-23
8.9	Calibration.....	8-31
8.10	Storage	8-32
8.11	Transporting and Disposal.....	8-33

8.1 Daily Maintenance

Before daily maintenance of the MP2110A, be sure to turn the power off and unplug it from the AC outlet.

Panel surface dirt

When surface dirt is noticeable, after the MP2110A has been used in a dusty environment, or when the MP2110A has not been used for an extended period of time, wipe its surface with a cloth soaked in detergent and wrung well.

Loose screws

Use a Phillips screwdriver to tighten screws.

8.2 Replacement of Optical Connector

The standard optical connector is the FC type. The optical connector can be removed and replaced with another connector (sold separately). For information, Figure 8.2-1 shows the connector type.

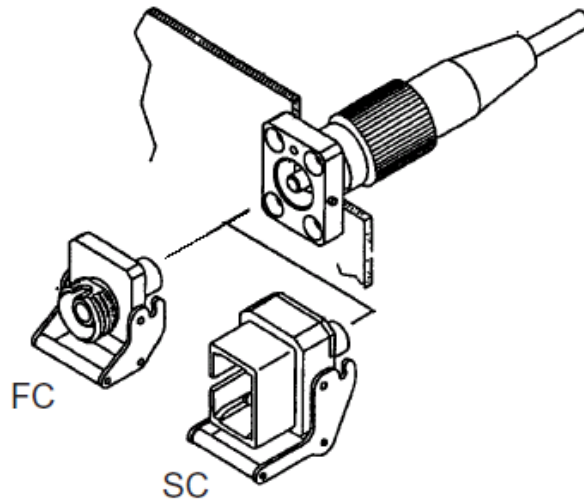

Figure 8.2-1 Connector Type

WARNING

Do not look into the connection surface of the optical fiber cable of the light source optical connector or the end face of the optical fiber cable connected to the light source as invisible laser light output may cause visual deficit and other problems.

CAUTION

Before replacing the optical fiber cable, be sure not to damage the connector and connection surface with connector.

To remove the optical connector:

1. Open the cover.
2. Pull up the connector lever toward you.
3. Check that the latch has been released, and then, gently pull the connector out straight toward you.

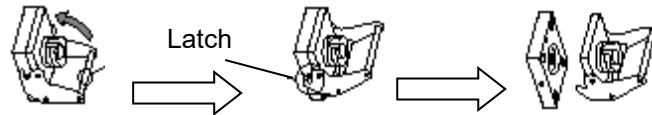

Figure 8.2-2 How to Remove the Optical Connector

8.3 Optical Connector/Optical Adapter Cleaning

Cleaning the Ferrule End Surface

Use an approved adapter cleaner to clean the ferrule end surface in the optical connector. The ferrule in the optical connectors needs periodic cleaning. Although the following procedures use the FC connector and adapter as an example, use the same methods when cleaning other connector and adapter types.

1. Remove the currently connected adapter by raising the adapter lever (you will hear a “click” when the latch disengages) and then gently pull the adapter straight towards you.

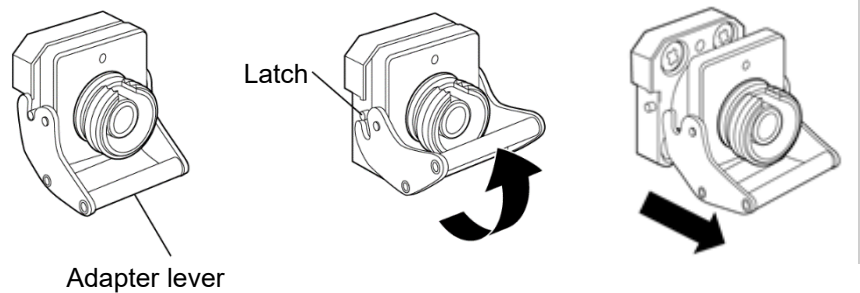

2. Moisten an adapter cleaner with isopropyl alcohol and then use it to clean the end surface and sides of the ferrule.

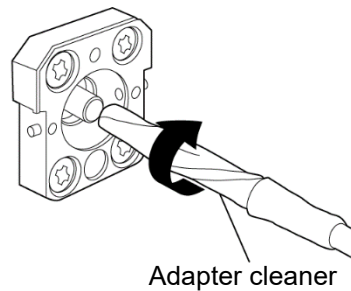

3. Press the tip of a new (dry) adapter cleaner into the ferrule end surface and then wipe in one direction 2 or 3 times to dry the surface.

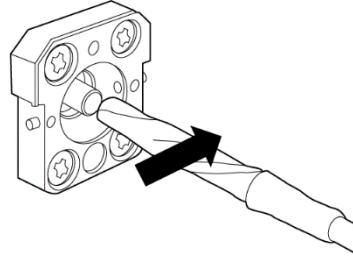

4. Clean the adapter interior with adapter cleaner. (Refer to “Cleaning the Optical Adapter” below.)
5. Attach the adapter in the reverse order. Be careful not to scratch the ferrule end surface.

Cleaning the Optical Adapter

Use an approved adapter cleaner to clean the optical fiber cable optical adapter. Although the following procedures use the FC connector and adapter as an example, use the same methods when cleaning other connector and adapter types.

Insert adapter cleaner into the split sleeve of the optical adapter. Rotate the adapter cleaner in one direction while moving it back and forth.

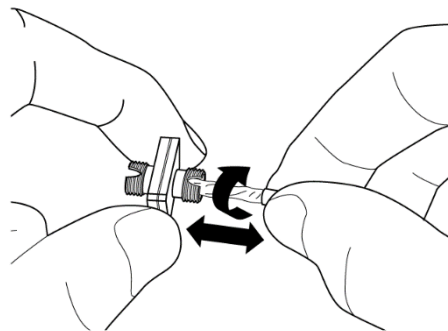

Note:

Check the ferrule diameter and use a cleaner only for the 1.25 mm or 2.5 mm adapter.

Cleaning the Optical Fiber Cable Ferrule End Surface

Use an approved ferrule cleaner to clean the optical fiber cable ferrule end surface. Although the following procedures use the FC connector and adapter as an example, use the same methods when cleaning other connector and adapter types.

1. Pull the ferrule cleaner lever to expose the cleaning surface.

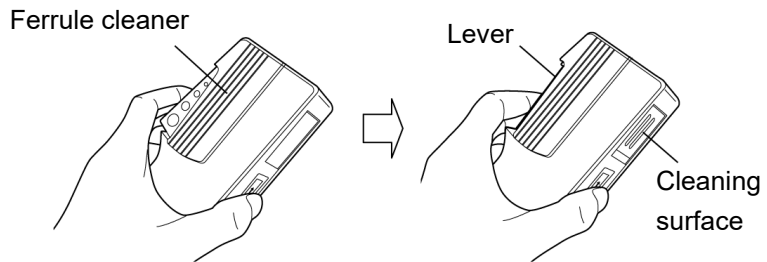

2. Hold the lever in the opened position, press the optical connector ferrule end into the cleaning surface, and then rub in one direction as shown in the following figure.

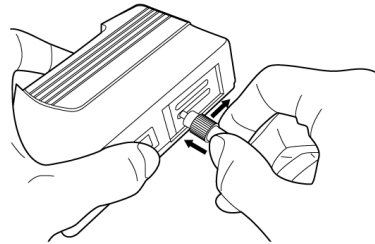

8.4 Displaying Software Version

Refer to Section 4.3.11 “System Information” for the software version display method.

8.5 Updating Software

For how to update the software, refer to the Release Notes. The Release Notes can be downloaded from the following Anritsu website.

<https://www.anritsu.com/en-US/test-measurement/support/downloads?model=MP2110A>

8.6 Adding an Option License

8.6.1 When adding the MP2110A-39x license

This procedure is applied to the following option:

MP2110A-395, MP2110A-396, or MP2110A-398

<Procedure>

1. Download the latest software (MX210000A) and Release Notes from the Anritsu website and update the software. For adding an option license, the software of version 6.01 or later is required.

<https://www.anritsu.com/test-measurement/support/downloads?mode=MP2110A>.

2. Check that the MP2110A Windows time is the current date and time. If the date and time are wrong, correct it in the Windows Control Panel.

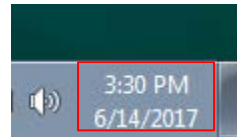

3. Copy the license file (lserverc_XXXX) to the MP2110A desktop.
4. If MX210000A is active, click **System Menu – Exit** to exit it.
5. Click **MX210000A – License** in Start Menu.

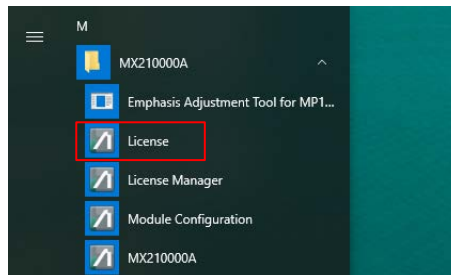

6. Click **Open** on **License Installer** dialog box.
7. Select the license file you copied in step 3 and click **OK**. The license information to be added is displayed.

- Click **Use License**. Wait for a while until the **License Installer** dialog box becomes available.

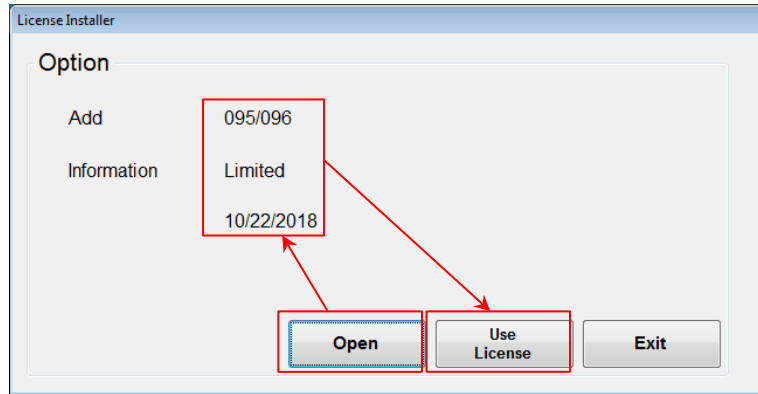

- Click **Exit** to close **License Installer** dialog box.
- Double-click MX210000A on the Desktop to launch the application.
- Click **System Menu – System Information** and confirm the added option.

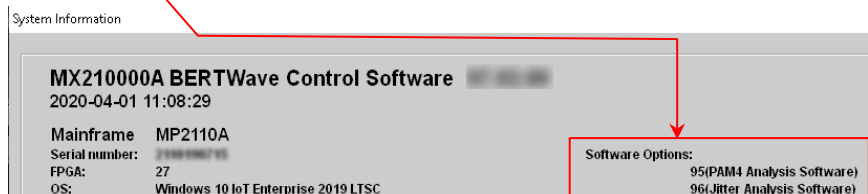
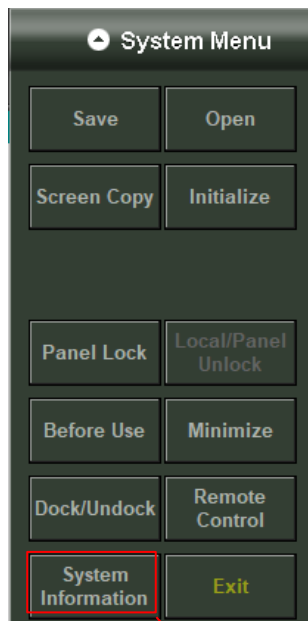

8.6.2 When adding other license than MP2110A-39x

<Procedure>

1. Download the latest software (MX210000A) and Release Notes from Anritsu Web site and update the software. For adding an option license, the software of version 7.04 or later is required.

<https://www.anritsu.com/test-measurement/support/downloads?mode=MP2110A>.

2. Check that the MP2110A Windows time is the current date and time. If the date and time are wrong, correct it in the Windows Control Panel.

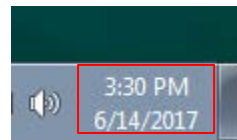

3. Copy the license file (OptionLicense.txt) to the MP2110A desktop.
4. If MX210000A is active, click **System Menu – Exit** to exit it.
5. Click **MX210000A – License Manager** in Start Menu.

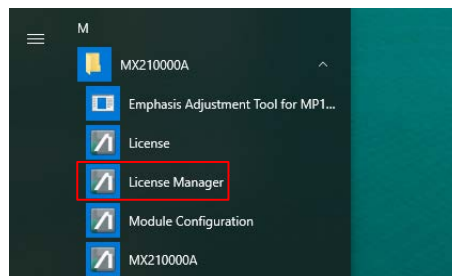

6. Click **Open** on **License Manager** dialog box.
7. Select the license file you copied in step 3 and click **OK**. The license information to be added is displayed.
8. Click **Use License**. Wait for a while until the **License Manager** dialog box becomes available.

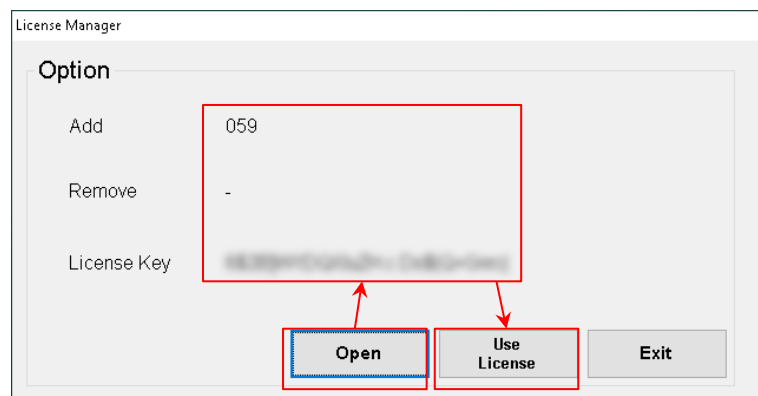

9. Click **Exit** to close **License Manager** dialog box.
10. Double-click MX210000A on the Desktop to launch the application.

11. Click **System Menu – System Information** and confirm the added option.

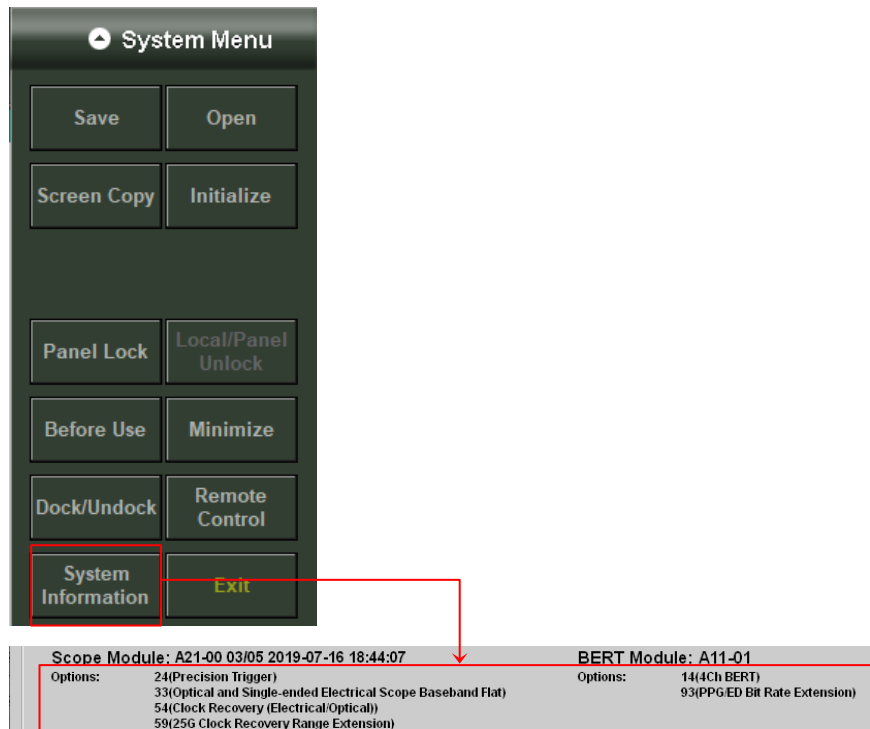

8.7 Initializing Corrected Data

The BERTWave Control Software MX210000A does not initialize some corrected data (to factory defaults) even if you click **System Menu > Initialize**. The following is a list of items outside the scope of **Initialize** and their initialization procedures.*

* The following items are also initialized if the system recovery is performed as described in 8.8.

Table 8.7-1 Items Outside Scope of Initialize

Item	Initialization Procedure
Conversion Gain / Responsivity (Refer to Table 6.2.5-1.)	<ol style="list-style-type: none"> 1. Set Control Ch to All. 2. Click Amplitude O/E to open the dialog box (Figure 6.2.5-2). 3. Click the O/E tab. <ul style="list-style-type: none"> • At Input Connector, select the wavelength to initialize. • Click Factory Reset.*
Noise Coefficient (Refer to Table 6.2.4-3.)	<ol style="list-style-type: none"> 1. Set Control Ch to All. 2. Click Measure to open the dialog box (Figure 6.2.4-1 or 6.2.4-2). 3. On the Amplitude/Time tab, click PAM4 to open the dialog box (Figure 6.2.4-4). 4. In the Setup (PAM4 Amplitude/Time) dialog box, click Reset at Noise Coefficient.*
Digital filter correction value	<ol style="list-style-type: none"> 1. If the MX210000A is started, click System Menu > Exit to exit the MX210000A. 2. Go to the following folder where the correction value file is saved. C:\Users\Public\Documents\Anritsu\MX210000A\SysFile 3. Delete the following file if it exists: <ul style="list-style-type: none"> • FilterCorrection.xml

*: If the settings have been changed from the factory defaults, the date and time of the change are displayed on the GUI. If there is no date display, initialization is not required.

8.8 System Recovery Function

The MP2110A has system recovery function to restore data on the hard disk to the factory shipment status. These functions can be used in the event of system instability.

CAUTION

Fully understand the following and back up all necessary data before performing a system recovery.

- **Executing system recovery restores the original Windows factory settings, and reverts the data stored on the C drive to the original factory state. All data such as applications and updates subsequently added, measurement conditions saved, measurement results, and screen captures will therefore be deleted.**
 - **Data deleted by these functions cannot be restored.**
 - **The MX210000A BERTWave Control Software must be re-installed if system recovery is performed. Before performing system recovery, prepare the MX210000A software installer for the version you are using.**
-

8.8.1 For WES7

<Procedure>

1. Disconnect the MP2110A from the network if connected.
2. Connect the keyboard and mouse to the mainframe, and then turn the MP2110A power On.

3. Press the **F8** key on the keyboard. The following screen will appear.

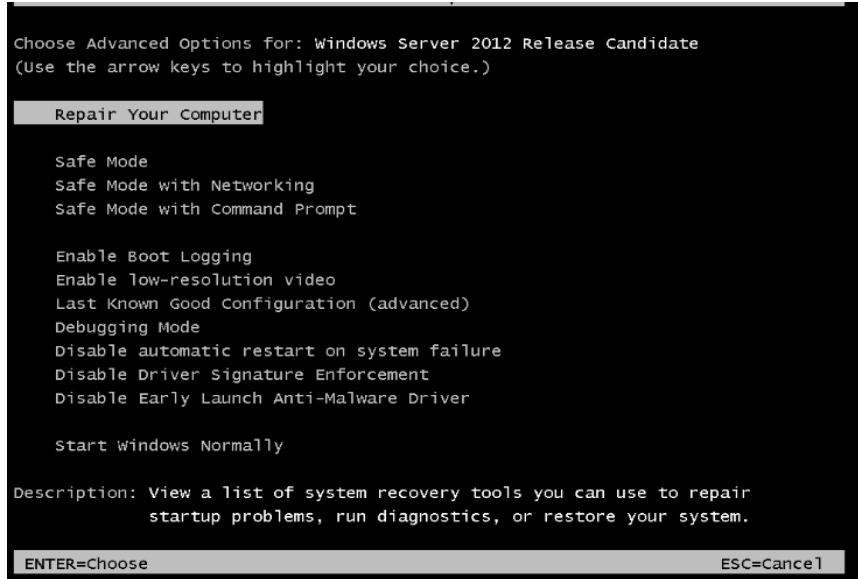

4. Use the keyboard cursor keys to select **Repair Your Computer**, and then press **Enter**.
5. Click **Next**.

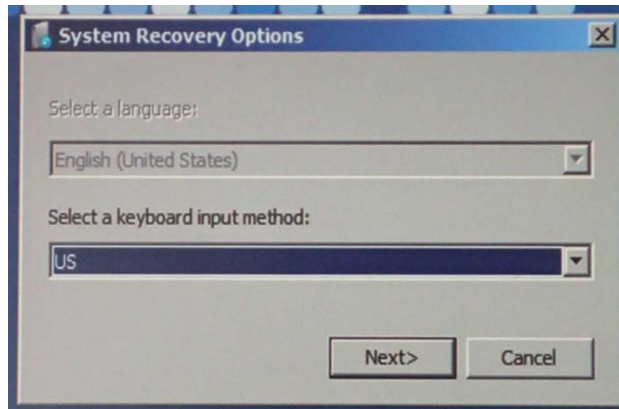

6. Click **OK**. Leave the Password box blank.



7. Click **Reinstall Windows**.

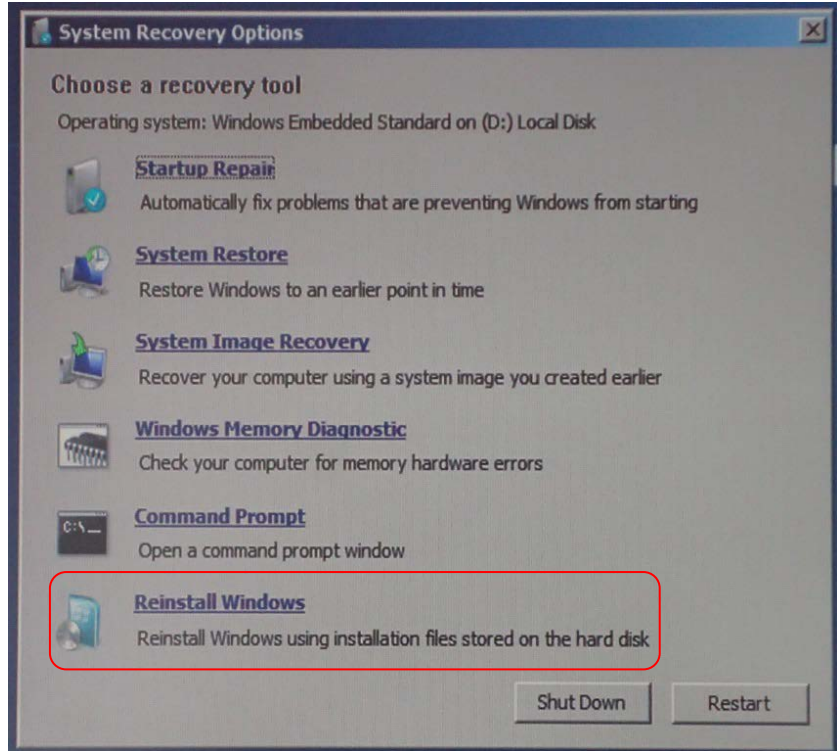

8. Click **Yes**.



- The recovery processing requires 10 to 30 minutes. The **Recovery** dialog box is displayed after restarting MP2110A several times. Click **Restore my files**.

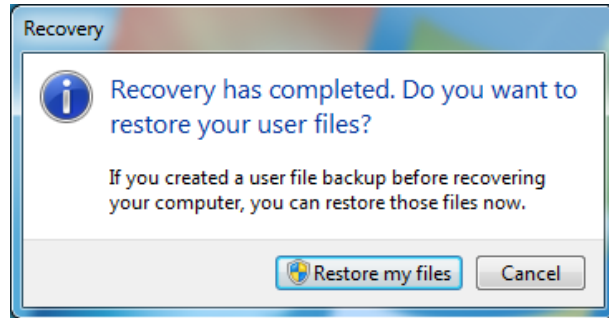

- Click **Cancel**.

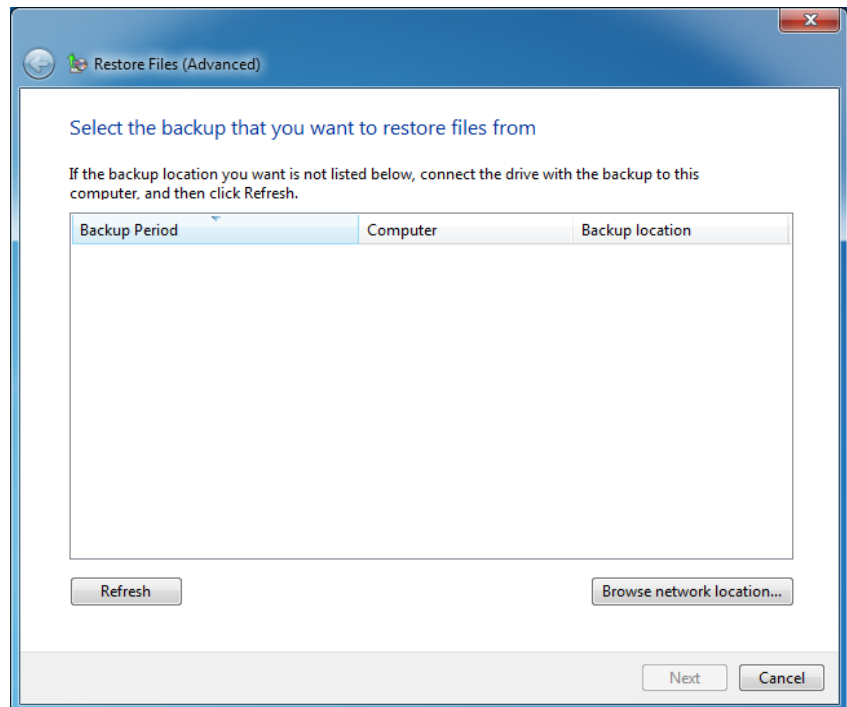

- Start Internet Explorer, and open the following folder.
C:\Program Files\Anritsu\PreSetup
- Right-click “Recovery.bat” and click **run as administrator**.
- Start Internet Explorer after restarting MP2110A. And check that the following folder is deleted.
c:\Windows.old
If the folder has not been deleted, repeat steps 11 and 12.

- In Control Panel, click **Network Connections**.

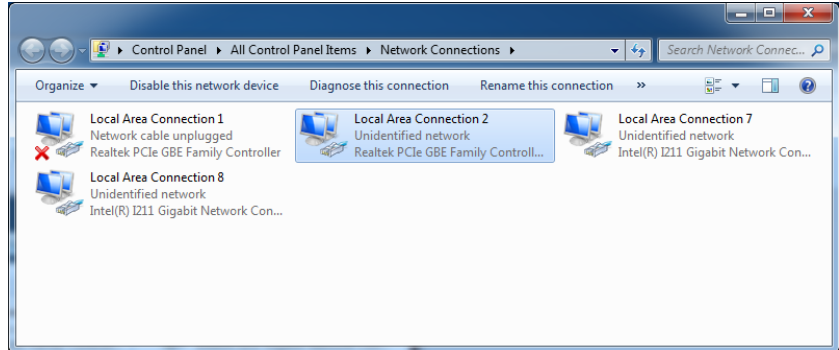

- Connect the cable to the Ethernet connector on the left side of the rear panel to establish the link.

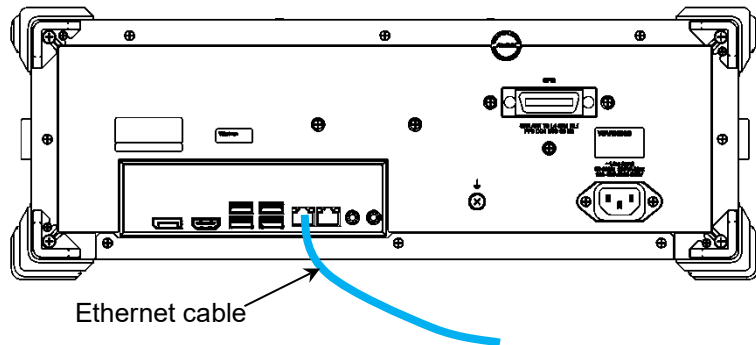

- Right-click the Realtek PCIe GBE Family Controller icon where the cross mark (x) is not displayed.
- Click **Rename**.
- Change the name to “Local Area Connection (Left)”.
- Right-click other Realtek PCIe GBE Family Controller icon.
- Click **Rename**.
- Change the name to “Local Area Connection (Right)”.

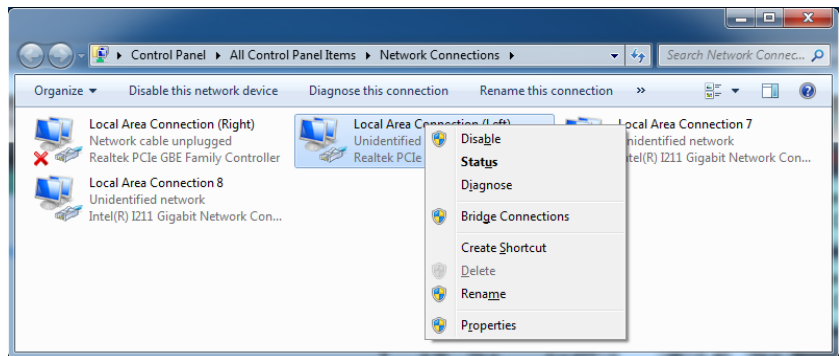

- Right-click the Intel ® I211 Gigabit Network Connection icon.
- Click **Rename**.
- Change the name to “DO NOT CHANGE 1”.

25. When there are two Intel ® I211 Gigabit Network Connection icons, right-click other Intel ® I211 Gigabit Network Connection icon.
26. Click **Rename**.
27. Change the name to “DO NOT CHANGE 2”.

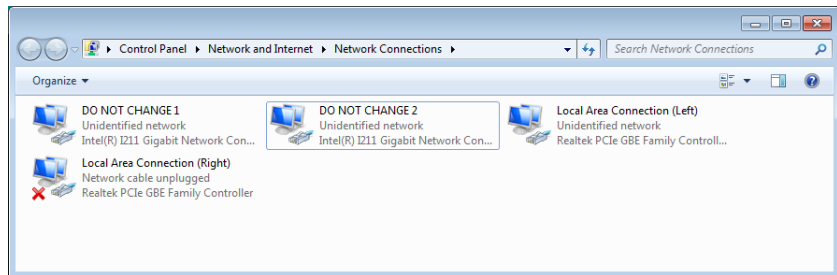

28. Click **All Programs** → **Windows Media Player** from the start menu.
29. Click **Custom Settings**, and click **Next**.



30. Check that all check boxes are not selected, and click **Next**.

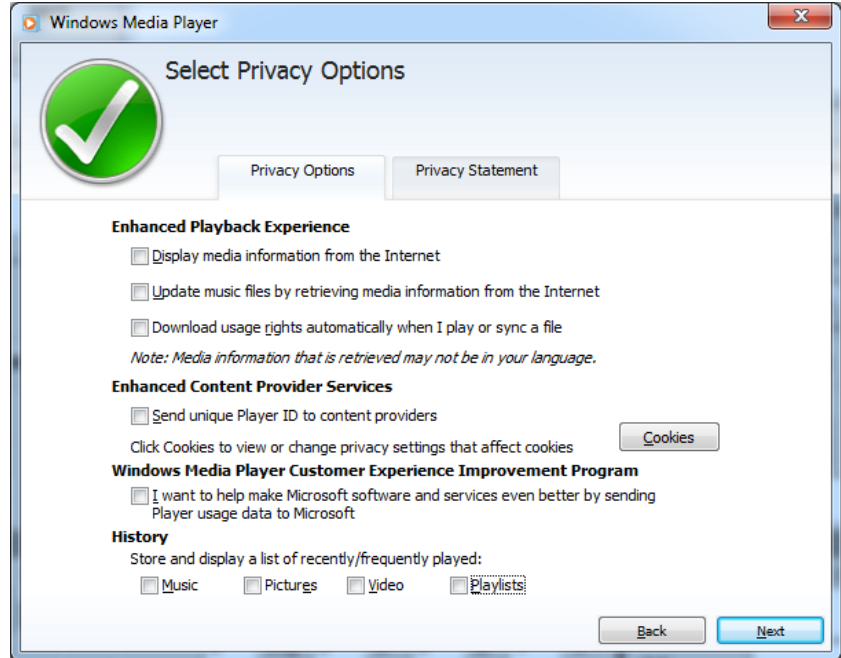

31. Click **Make Windows Media Player the default music and video player**, and click **Finish**.

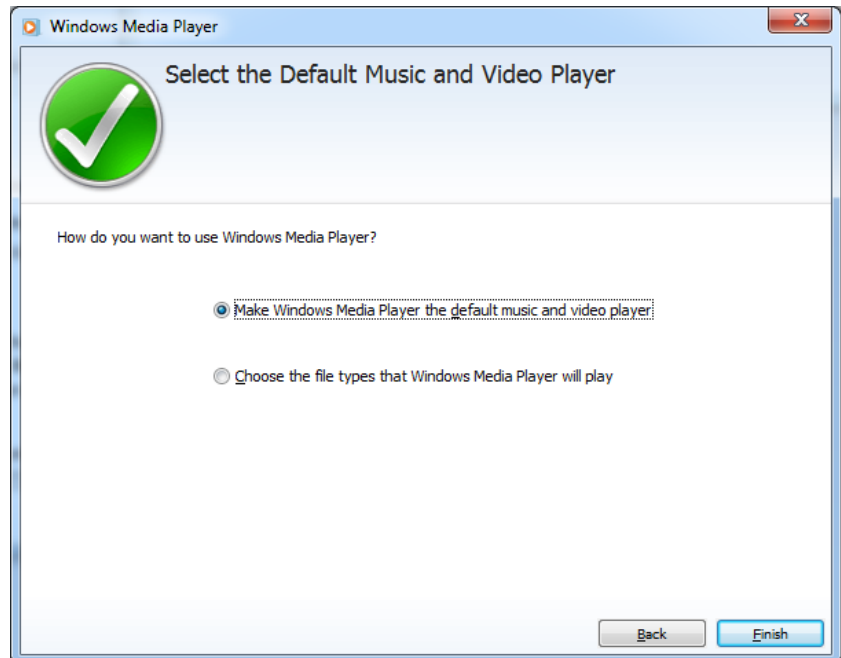

32. Install the BERTWave Control Software (MX210000A) in accordance with the release note. The **Module Configuration** dialog box is displayed after launching the installer. Select the modules installed in MP2110A, and click **OK**.

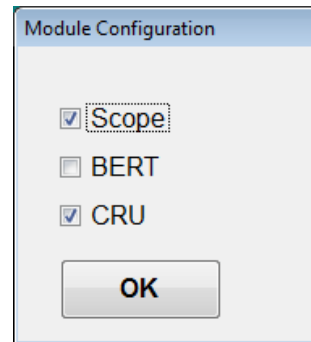

The above dialog box is displayed by clicking **MX210000A** → **Module Configuration** from the start menu of Windows. If the wrong module is selected, display the **Module Configuration** dialog box and select the module again.

33. Configure Windows Firewall exceptions. Refer to 2.11.1 “Activating Firewall”.

Checking operation

Check the operation using the following procedure after recovering the system.

1. Click **All Programs** → **MX210000A** → **MX210000A** from the start menu of Windows.
2. Click **System Menu – Remote Control**. Check that Local Area Connection (Left) and Local Area Connection (Right) are displayed in the **Remote Control** dialog box (refer to Figure 4.3.10-1).
3. Click **System Menu – Before Use**. Check that the video of countermeasure against static electricity is played back.

8.8.2 For Win10

<Procedure>

1. Disconnect the MP2110A from the network if connected.
2. Connect the keyboard and mouse to the mainframe, and then turn the MP2110A power On.
3. Press the **F8** key on the keyboard. The following screen will appear.



4. Use the keyboard cursor keys to select **Repair Your Computer**, and then press **Enter**.
5. In the **Choose an option** screen, click **Troubleshoot**.

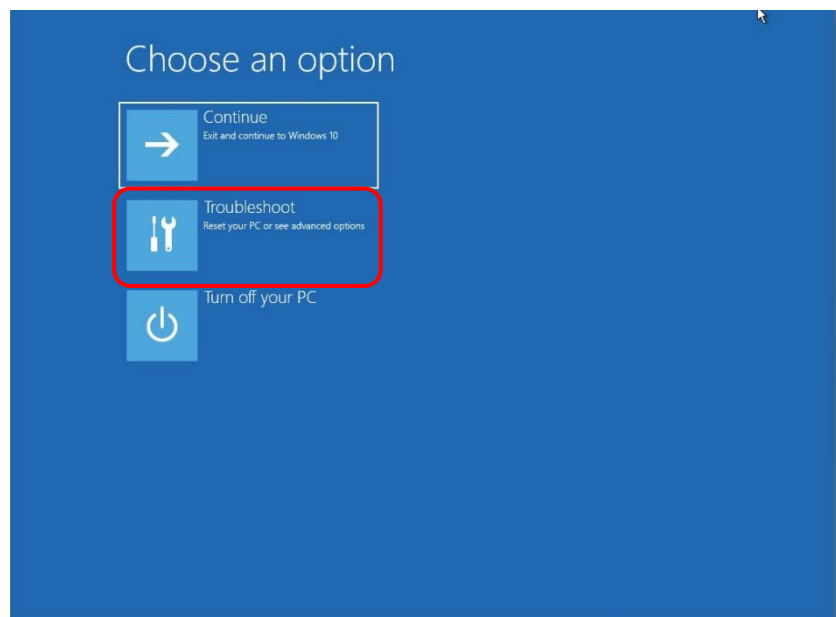

6. In the **Troubleshoot** screen, click **Advanced options**.

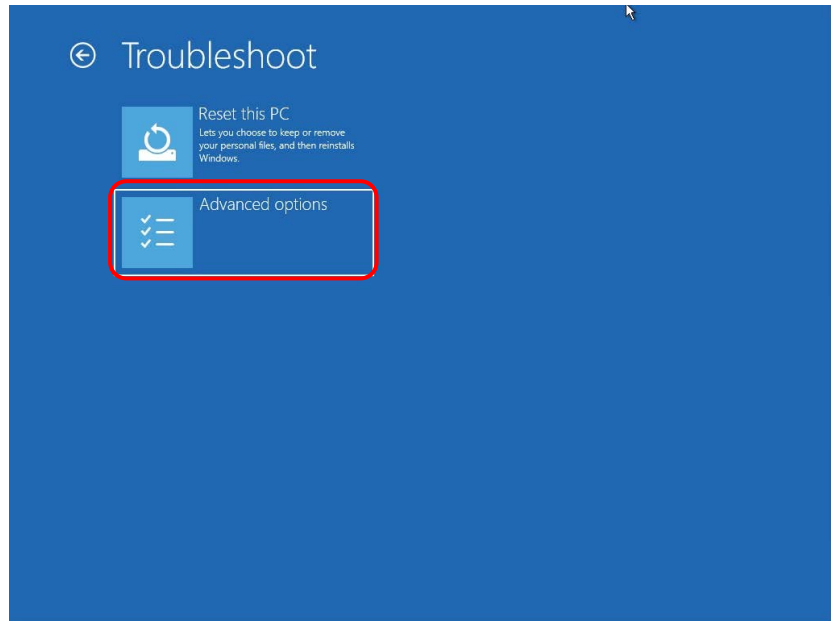

7. In the **Advanced options** screen, click **System Image Recovery**.

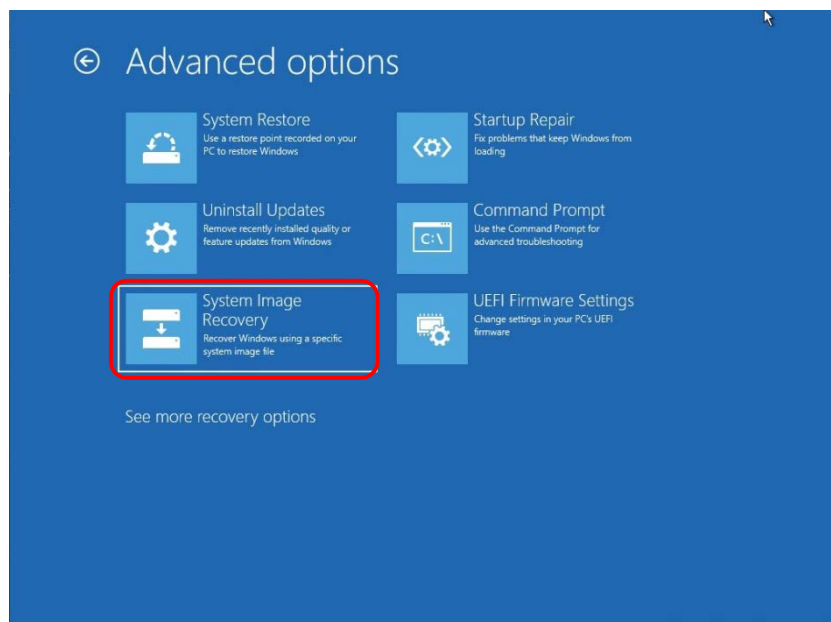

- In the **System Image Recovery** screen, click **AnritsuUser**,

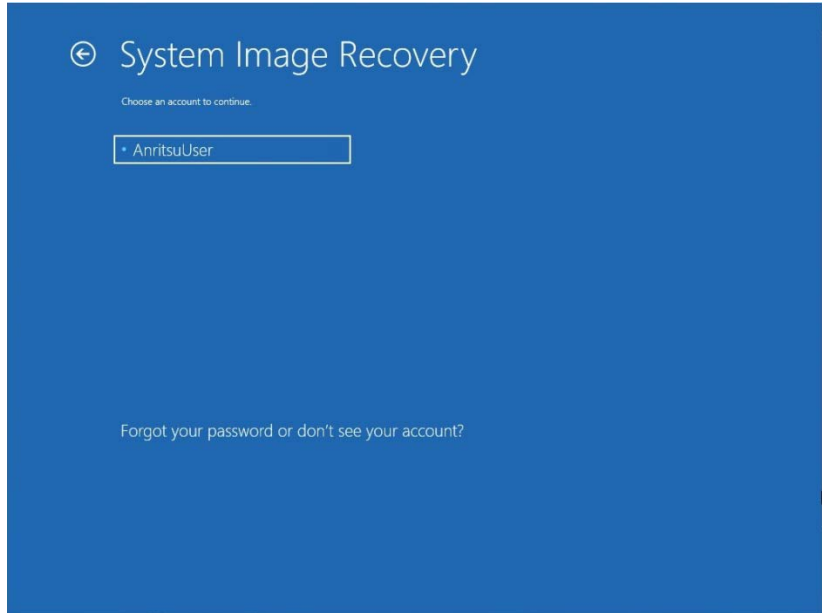

- When you are prompted to enter the password, leave it blank, and then click **Continue**.

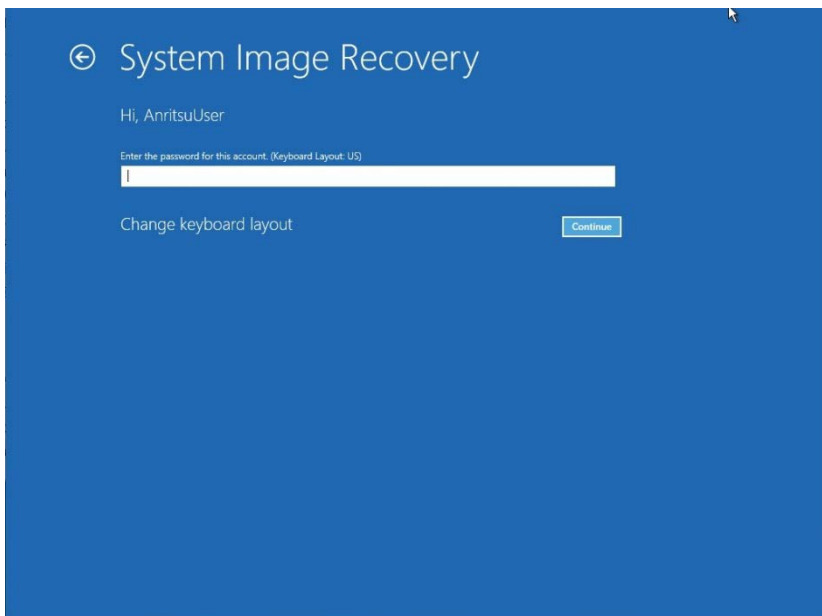

10. In the **Select a system image backup** page, select **Use the latest available system image(recommended)**, and click **Next**.

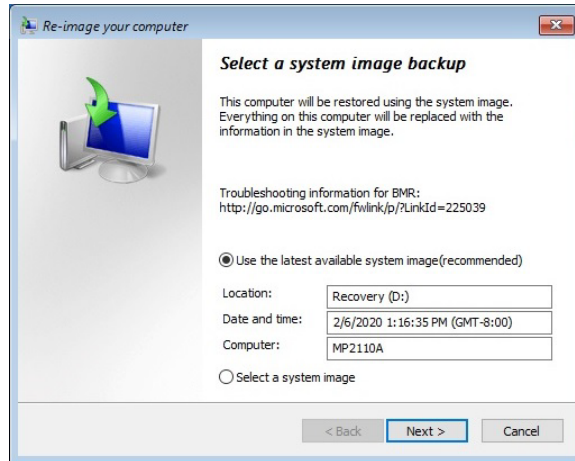

11. In the **Choose additional restore options** page, and click **Next** without any changes.

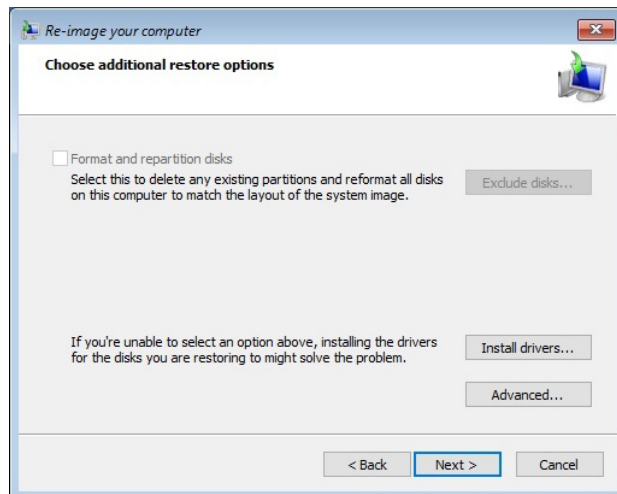

12. When "Your computer will be restored from the following system image:" appears, click **Finish**.
13. When the confirmation screen appears, click **Yes** to start a system recovery.
The Progress bar appears, and the recovery process starts.
Do not click **Stop restore** when a system recovery is in progress.
Although the time required for recovery varies depending on the conditions, it normally takes about ten minutes.
14. After the system recovery is completed, the MP2110A restarts automatically, and Windows starts.

- Click  on the taskbar and type “Control Panel” in the Search box.



- Click Control Panel icon.
- Click **Network and Internet**.
- Click **Network and Sharing Center**.
- Click **Change adapter settings**.

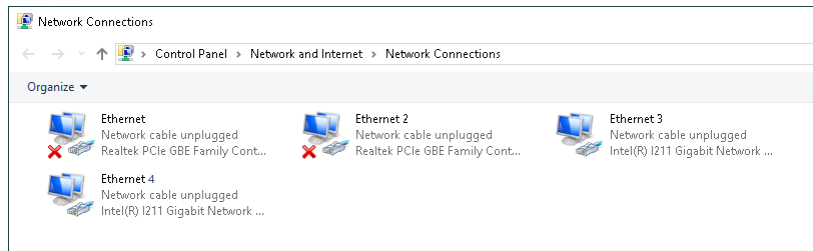

- Connect the cable to the Ethernet connector on the left side of the rear panel to establish the link.

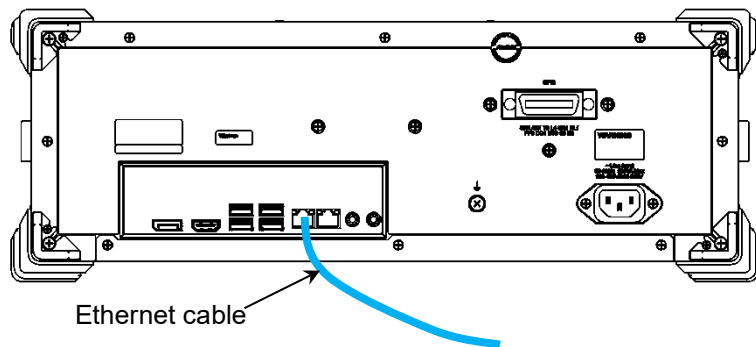

- Right-click the Realtek PCIe GBE Family Controller icon where the cross mark (X) is not displayed.
- Click **Rename**.

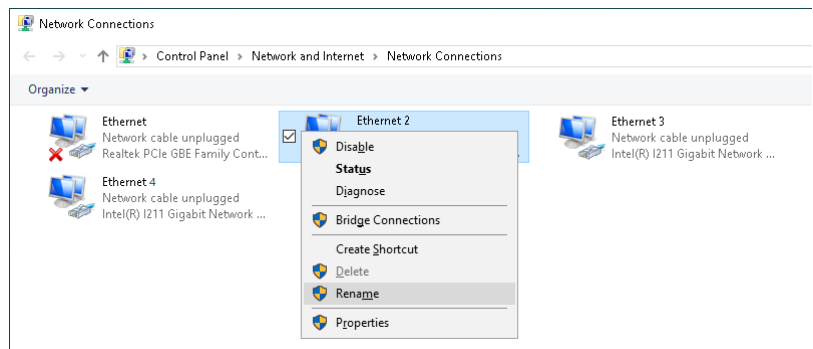

- Change the name to “Local Area Connection (Left)”.
- Right-click other Realtek PCIe GBE Family Controller icon.
- Click **Rename**.
- Change the name to “Local Area Connection (Right)”.
- Right-click the Intel® I211 Gigabit Network Connection icon.

- 28. Click **Rename**.
- 29. Change the name to “DO NOT CHANGE 1”.
- 30. When there are two Intel ® I211 Gigabit Network Connection icons, right-click other Intel ® I211 Gigabit Network Connection icon.
- 31. Click **Rename**.
- 32. Change the name to “DO NOT CHANGE 2”.

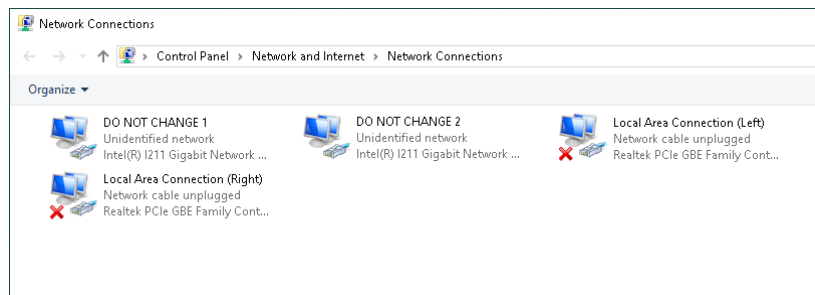

- 33. Click **Start** (Windows logo) → **Windows Media Player** from the start menu.
- 34. Click **Custom Settings**, and click **Next**.



35. Check that all check boxes are not selected, and click **Finish**.

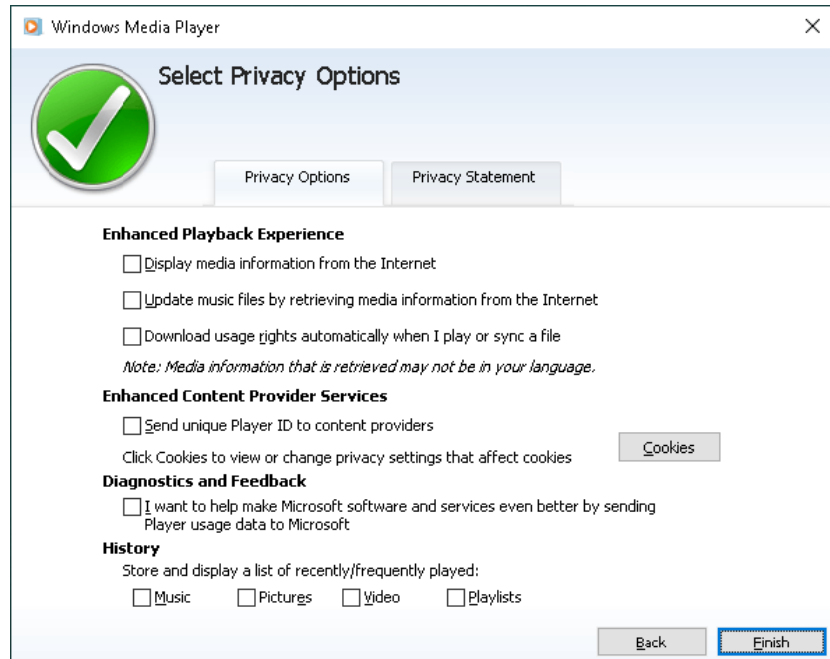

36. Windows Media Player starts. Click “x” on the top right corner of the Windows Media Player window to close it.
37. Install the BERTWave Control Software (MX21000A) in accordance with the release notes. For the release notes, refer to 8.5 “Updating Software”.
38. The **Module Configuration** dialog box is displayed after launching the installer. Select the modules installed in MP2110A, and click **OK**.

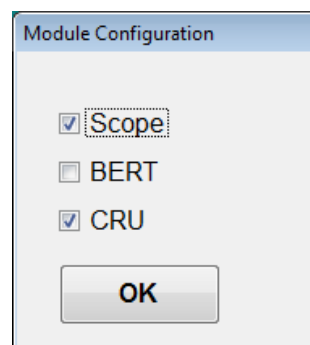

The above dialog box is displayed by clicking **MX21000A** → **Module Configuration** from the start menu of Windows. If the wrong module is selected, display the **Module Configuration** dialog box and select the module again.

39. Configure Windows Firewall exceptions. Refer to 2.11.1 “Activating Firewall”.

Checking operation

Check the operation using the following procedure after recovering the system.

1. Click **Start**  → **MX210000A** → **MX210000A** .
2. Click **System Menu** → **Remote Control**. Check that Local Area Connection (Left) and Local Area Connection (Right) are displayed in the **Remote Control** dialog box (refer to Figure 4.3.10-1).
3. Click **System Menu** → **Before Use**. Check that the video of countermeasure against static electricity is played back.

8.9 Calibration

Regular maintenance such as periodic inspections and calibration is essential for the MP2110A for long-term stable performance. Regular inspection and calibration are recommended for using the MP2110A in its prime condition at all times. The recommended calibration cycle after delivery of the MP2110A is twelve months.

If you require support after delivery, contact an Anritsu Service and Sales office. Contact information can be found on the last page of the printed version of this manual, and is available in a separate file on the PDF version.

We may not provide calibration or repair if any of the following cases apply.

- Seven or more years have elapsed after production and parts for the instrument are difficult to obtain, or it is determined that reliability cannot be maintained after calibration/repair due to significant wear.
- Circuit changes, repair, or modifications are done without our approval.
- It is determined that the repair cost would be higher than the price of a new item.

8.10 Storage

Wipe off dust, fingerprint marks, stains, spots, etc. from the surface of the MP2110A before storing it.

Fit the attached coaxial connector cover to the coaxial connector on the front panel. Also, put the cap on the optical connector.

Put the power cord, DVD-ROM and other accessories in the accessory box and store it with the main frame.

For an Optical Scope, FC adaptor cap should be in place when the MP2110A is not in use to prevent foreign material from entering the optical connector.

Avoid storing the MP2110A in these places:

- In direct sunlight for extended periods
- Outdoors
- In excessively dusty locations
- In liquids, such as water, oil, organic solvents, and medical fluids, or places where these liquids may adhere
- In salty air or where chemically active gases (sulfur dioxide, hydrogen sulfide, chlorine, ammonia, nitrogen oxide, or hydrogen chloride etc.) are present
- Where toppling over may occur
- In the presence of lubricating oil mists
- In places at an altitude of more than 2,000 m
- In the presence of frequent vibration and mechanical shock, such as in cars, ships, and airplanes
- Places with temperatures and relative humidity in the following ranges:

Temperature:	lower than -20°C or higher than 60°C
Humidity:	90% or more

Recommended storage conditions

It is recommended that the MP2110A be stored in a place that meets the ambient conditions suggested above, plus the following conditions, if it is not to be used for a long period of time:

- Temperature: 5 to 45°C
- Humidity: 40 to 80%
- Little temperature and humidity fluctuations within one day

8.11 Transporting and Disposal

The following describes precautions for transporting and disposing of the BERTWave.

Repackaging

Repack the MP2110A in the packing material (box) in which it was delivered. If the packing material has been thrown away or damaged, repack the MP2110A in the following manner:

1. Prepare a corrugated cardboard, wooden, or aluminum box large enough to pack cushioning material in around the MP2110A.
2. Wrap the MP2110A in plastic or a similar material to avoid water droplets and dust.
3. Put the MP2110A in the box.
4. Pack the MP2110A in cushioning material so it does not move in the box.
5. Secure the outside of the box with packing cord, adhesive tape, bands, or other similar materials.

Transporting

Avoiding vibrations as much as possible and meet the recommended storage conditions during transport.

Disposal

Follow the instructions of your local waste disposal office when disposing of the MP2110A.

Before disposing of the MP2110A, dismantle or physically destroy any memory media it contains to ensure that any data saved in memory cannot be recovered by third parties.

Appendix A Specifications

Appendix A describes the specifications for the MP2110A.

Only the specifications of the option installed at shipment are described from Section A.2 “BERT” to Section A.4, “General Performance”. However, the specifications of the retrofit option and the specifications of the option installed at shipment are the same.

A.1	Configuration.....	A-2
A.2	BERT	A-7
	A.2.1 Common Performances.....	A-7
	A.2.2 Pulse Pattern Generator.....	A-9
	A.2.3 Error Detector	A-10
A.3	Sampling Oscilloscope	A-12
	A.3.1 Channel Configuration.....	A-12
	A.3.2 Common Performances.....	A-12
	A.3.3 Time Setting	A-14
	A.3.4 Measurement.....	A-15
	A.3.5 Utilities	A-21
	A.3.6 Maintenance	A-21
	A.3.7 Horizontal System	A-22
	A.3.8 Digital System.....	A-22
	A.3.9 Electrical Channel.....	A-23
	A.3.10 Optical Channel.....	A-26
	A.3.11 CRU (MP2110A-x54).....	A-31
	A.3.12 26G/53G CRU (MP2110A-x55).....	A-33
A.4	General Performance	A-35

A.1 Configuration

Table A.1-1 Standard Configuration

Model/Ordering No.	Product Name	Q'ty
MP2110A	– Main unit – BERTWave	1
	– Standard Accessories – Power Code	1
J0617B	Replaceable optical connector (FC-PC)	*1
J1632A	TERMINATOR	*1
J1341A	OPEN	*1
J1627A	GND connection cable	1
J1763A	U Link Coaxial Cable (K)	1*2
J1764A	U Link Coaxial Cable (SMA)	1*2
Z0397A	FC Adaptor Cap	*1
Z1364A	MX210000A BERTWave Control Software CD-ROM	1

*1: Quantity depends on the options. Refer to Table A.1-2 to Table A.1-4.

*2: Only when MP2100A-x54 is added

Table A.1-2 Connection Destination and Quantity of J0617B and Z0397A

Option Number	Connection Destination	Q'ty
MP2110A-x22, MP2110A-x32, MP2110A-x42	Ch A In SMF, Ch A In MMF, Ch B In SMF, Ch B In MMF	4
MP2110A-x23, MP2110A-x33, MP2110A-x43	Ch B In SMF, Ch B In MMF	2
MP2110A-x25, MP2110A-x35, MP2110A-x45	Ch B In SMF	1
MP2110A-x26, MP2110A-x36, MP2110A-x46	Ch B In MMF	1
MP2110A-x30, MP2110A-x40	Optical In SMF Ch A, Ch B, Ch C, Ch D	4
MP2110A-x39, MP2110A-x49	Optical In MMF Ch A, Ch B, Ch C, Ch D	4
MP2110A-x55	Optical SMF Data In, Data Out	2

Table A.1-3 Connection Destination and Quantity of J1632A

Option Number	Connection Destination	Q'ty
MP2110A-x11	Data Out×1, $\overline{\text{Data}}$ Out×1, $\overline{\text{Sync}}$ Out×1	3
MP2110A-x12	Data Out×2, $\overline{\text{Data}}$ Out×2, $\overline{\text{Sync}}$ Out×1	5
MP2110A-x14	Data Out×4, $\overline{\text{Data}}$ Out×4, $\overline{\text{Sync}}$ Out×1	9
MP2110A-x54	O/E Monitor Out×1	1*

*: When MP2110A-x22, MP2110A-x23, MP2110A-x25, MP2110A-x26, MP2110A-x30, MP2110A-x32, MP2110A-x33, MP2110A-x35, MP2110A-x36, MP2110A-x39, MP2110A-x40, MP2110A-x42, MP2110A-x43, MP2110A-x45, MP2110A-x46, or MP2110A-x49 is added.

Table A.1-4 Connection Destination and Quantity of J1341A

Option Number	Connection Destination	Q'ty
MP2110A-x11	Ext Clk In, Clk Out, Sync Out×1, Data In×1, $\overline{\text{Data}}$ In×1	5
MP2110A-x12	Ext Clk In, Clk Out, Sync Out×1, Data In×2, $\overline{\text{Data}}$ In×2	7
MP2110A-x14	Ext Clk In, Clk Out, Sync Out×1, Data In×4, $\overline{\text{Data}}$ In×4	11
MP2110A-x21	Trigger Clk In, Ch A In, Ch B In	3
MP2110A-x22, MP2110A-x32, MP2110A-x42	Trigger Clk In	1
MP2110A-x23, MP2110A-x33, MP2110A-x43	Trigger Clk In, Ch A In	2
MP2110A-x25, MP2110A-x35, MP2110A-x45	Trigger Clk In	1
MP2110A-x26, MP2110A-x36, MP2110A-x46	Trigger Clk In	1
MP2110A-x30, MP2110A-x39, MP2110A-x40, MP2110A-x49	Trigger Clk In	1
MP2110A-x54	CRU In×1, CRU Out×1	2
MP2110A-x55	Recovered Clock Out×1	1

Table A.1-5 Options

Model	Product Name
	– Options at Shipment –
MP2110A-011	1CH BERT*1,*2
MP2110A-012	2CH BERT*1,*2
MP2110A-014	4CH BERT*1,*2
MP2110A-021	Dual Electrical Scope*1,*3
MP2110A-022	Dual Optical Scope*1,*3
MP2110A-023	Optical and Single-ended Electrical Scope*1,*3
MP2110A-024	Precision Trigger*4
MP2110A-025	Optical Scope for Singlemode*1,*3
MP2110A-026	Optical Scope for Multimode*1,*3
MP2110A-030	Quad Optical Scope for Singlemode Baseband Flat*1,*3
MP2110A-032	Dual Optical Scope Baseband Flat*1,*3
MP2110A-033	Optical and Single-ended Electrical Scope Baseband Flat*1,*3
MP2110A-035	Optical Scope for Singlemode Baseband Flat*1,*3
MP2110A-036	Optical Scope for Multimode Baseband Flat*1,*3
MP2110A-039	Quad Optical Scope for Multimode Baseband Flat*1,*3
MP2110A-040	Quad Optical Scope for Singlemode*1,*3
MP2110A-042	Dual Optical Scope*1,*3
MP2110A-043	Optical and Single-ended Electrical Scope*1,*3
MP2110A-045	Optical Scope for Singlemode*1,*3
MP2110A-046	Optical Scope for Multimode*1,*3
MP2110A-049	Quad Optical Scope for Multimode*1,*3
MP2110A-054	Clock Recovery (Electrical/Optical)*5
MP2110A-055	26G/53Gbaud Clock Recovery (SM Optical)*6
MP2110A-059	25G Clock Recovery Range Extension*7
MP2110A-061	Low Noise and Multimode Support for Opt.040*8
MP2110A-093	PPG/ED Bit Rate Extension*9
MP2110A-095	PAM4 Analysis Software*5
MP2110A-096	Jitter Analysis Software*5
MP2110A-098	Signal Processing Software*5
	– Retrofit Options –
MP2110A-110	Windows10 Upgrade Retrofit
MP2110A-111	1CH BERT Retrofit*10
MP2110A-112	2CH BERT Retrofit*11
MP2110A-114	4CH BERT Retrofit*12
MP2110A-121	Dual Electrical Scope Retrofit*13
MP2110A-122	Dual Optical Scope Retrofit*13, *14
MP2110A-123	Optical and Single-ended Electrical Scope Retrofit*13, *14
MP2110A-124	Precision Trigger Retrofit*4
MP2110A-125	Optical Scope for Singlemode Retrofit*13, *14
MP2110A-126	Optical Scope for Multimode Retrofit*13, *14

Table A.1-5 Options (Cont'd)

Model	Product Name
MP2110A-130	Quad Optical Scope for Singlemode Baseband Flat Retrofit* ¹³ , * ¹⁴
MP2110A-132	Dual Optical Scope Baseband Flat Retrofit* ¹³ , * ¹⁴
MP2110A-133	Optical and Single-ended Electrical Scope Baseband Flat Retrofit* ¹³ , * ¹⁴
MP2110A-135	Optical Scope for Singlemode Baseband Flat Retrofit* ¹³ , * ¹⁴
MP2110A-136	Optical Scope for Multimode Baseband Flat Retrofit* ¹³ , * ¹⁴
MP2110A-139	Quad Optical Scope for Multimode Baseband Flat Retrofit* ¹³ , * ¹⁴
MP2110A-140	Quad Optical Scope for Singlemode Retrofit* ¹³ , * ¹⁴
MP2110A-142	Dual Optical Scope Retrofit* ¹³ , * ¹⁴
MP2110A-143	Optical and Single-ended Electrical Scope Retrofit* ¹³ , * ¹⁴
MP2110A-145	Optical Scope for Singlemode Retrofit* ¹³ , * ¹⁴
MP2110A-146	Optical Scope for Multimode Retrofit* ¹³ , * ¹⁴
MP2110A-149	Quad Optical Scope for Multimode Retrofit* ¹³ , * ¹⁴
MP2110A-154	Clock Recovery (Electrical/Optical) Retrofit* ⁵
MP2110A-155	26G/53Gbaud Clock Recovery (SM Optical) Retrofit* ¹⁵
MP2110A-159	25G Clock Recovery Range Extension Retrofit* ⁷ , * ¹⁶
MP2110A-193	PPG/ED Bit Rate Extension Retrofit * ⁹
MP2110A-195	PAM4 Analysis Software Retrofit* ⁵
MP2110A-196	Jitter Analysis Software Retrofit* ⁵
MP2110A-198	Signal Processing Software Retrofit* ⁵
	– User-installable options –
MP2110A-359	25G Clock Recovery Range Extension Retrofit* ⁷
MP2110A-395	PAM4 Analysis Software Retrofit* ⁵
MP2110A-396	Jitter Analysis Software Retrofit* ⁵
MP2110A-398	Signal Processing Software Retrofit* ⁵

*1: One or more these options are required.

*2: Select one of the BERT options.

BERT options are MP2110A-x11, x12, and x14.

*3: Select one of the Scope options.

Scope options are MP2110A-x21, x22, x23, x25, x26, x30, x32, x33, x35, x36, x39, x40, x42, x43, x45, x46, and x49.

MP2110A-02x represents MP2110A-022, 023, 025, and 026.

MP2110A-03x represents MP2110A-030, 032, 033, 035, 036 and 039.

MP2110A-04x represents MP2110A-040, 042, 043, 045, 046 and 049.

*4: One of the Scope options other than MP2110A-x30, x39, x40 and x49 is required.

*5: Can be selected with the Scope option.

*6: Cannot be installed with BERT options.

*7: MP2110A-x54 is required.

*8: MP2110A-x40 is required.

*9: Can be selected with the BERT option.

*10: When MP2110A-x11, x12, or x14 is not installed.

*11: When MP2110A-x12 or x14 is not installed.

*12: When MP2110A-x14 is not installed.

*13: When Scope option is not installed.

*14: The retrofit options can be installed in the following cases:

- When no Scope option is installed.
- When a Scope option is installed, the retrofit option is MP2110A-02x, 03x or 04x with the same channel configuration. See the following table for available combinations of installed options and retrofit options.

Installed Option	Retrofit Option	Installed Option	Retrofit Option
MP2110A-022	MP2110A-132, MP2110A-142	MP2110A-036	MP2110A-146
MP2110A-023	MP2110A-133, MP2110A-143	MP2110A-039	MP2110A-149
MP2110A-025	MP2110A-135, MP2110A-145	MP2110A-040	MP2110A-130
MP2110A-026	MP2110A-136, MP2110A-146	MP2110A-042	MP2110A-132
MP2110A-030	MP2110A-140	MP2110A-043	MP2110A-133
MP2110A-032	MP2110A-142	MP2110A-045	MP2110A-135
MP2110A-033	MP2110A-143	MP2110A-046	MP2110A-136
MP2110A-035	MP2110A-145	MP2110A-049	MP2110A-139

*15: When BERT option or MP2110A-x55 is not installed.

*16: Available only when ordering with MP2110A-x54.

A.2 BERT

A.2.1 Common Performances

Table A.2.1-1 Common Functions and Performances

Item	Specifications												
Internal clock Frequency Accuracy Bit rate offset	10 MHz ± 10 ppm ^{*1} ± 100 ppm ^{*2}												
Ext Clk In Frequency Connector Termination Amplitude Waveform Division ratio	Function to input an external synchronous clock. <table border="1"> <thead> <tr> <th>Without MP2110A-x93</th> <th>With MP2110A-x93</th> </tr> </thead> <tbody> <tr> <td>607.5 MHz – 100 ppm to 705.0 MHz + 100 ppm</td> <td>593.75 MHz – 100 ppm to 887.5 MHz + 100 ppm^{*3}</td> </tr> <tr> <td></td> <td>607.5 MHz – 100 ppm to 705.0 MHz + 100 ppm^{*4}</td> </tr> </tbody> </table> SMA, female 50 Ω , AC coupled 0.2 to 1.6 V _{p-p} Square or sine wave <table border="1"> <thead> <tr> <th>Without MP2110A-x93</th> <th>With MP2110A-x93</th> </tr> </thead> <tbody> <tr> <td>1/40</td> <td>1/16^{*3}</td> </tr> <tr> <td></td> <td>1/40^{*4}</td> </tr> </tbody> </table>	Without MP2110A-x93	With MP2110A-x93	607.5 MHz – 100 ppm to 705.0 MHz + 100 ppm	593.75 MHz – 100 ppm to 887.5 MHz + 100 ppm ^{*3}		607.5 MHz – 100 ppm to 705.0 MHz + 100 ppm ^{*4}	Without MP2110A-x93	With MP2110A-x93	1/40	1/16 ^{*3}		1/40 ^{*4}
Without MP2110A-x93	With MP2110A-x93												
607.5 MHz – 100 ppm to 705.0 MHz + 100 ppm	593.75 MHz – 100 ppm to 887.5 MHz + 100 ppm ^{*3}												
	607.5 MHz – 100 ppm to 705.0 MHz + 100 ppm ^{*4}												
Without MP2110A-x93	With MP2110A-x93												
1/40	1/16 ^{*3}												
	1/40 ^{*4}												
Sync Output Output Signal Type Output Level Connector	1/8, 1/16, 1/40, Pattern Sync High Level (V _{OH}): –0.2 to 0.05 V Low Level (V _{OL}): –1.2 to –0.7 V SMA, female												

*1: 1 hour after power-on

*2: The offset can adjust only when using the internal clock. (Common setting in all channels)

*3: When operation bit rate is set in the range of 9.5 to 14.2 Gbit/s.

*4: When operation bit rate is set in the range of 24.3 to 28.2 Gbit/s.

Table A.2.1-1 Common Functions and Performances (Cont'd)

Item	Specifications																																																																																			
Clock Output* ⁵ Clock Source* ⁶ Division ratio Amplitude Duty Connector Termination	Ch1/2, Ch3/4																																																																																			
	Without MP2110A-x93		With MP2110A-x93																																																																																	
	1/4		1/2* ³																																																																																	
			1/4* ⁴																																																																																	
Operation Bit Rate	<table border="1"> <thead> <tr> <th colspan="2" data-bbox="488 824 732 875">Without MP2110A-x93</th> <th colspan="2" data-bbox="732 824 1441 875">With MP2110A-x93</th> </tr> <tr> <th data-bbox="488 875 732 954">Standard Name</th> <th data-bbox="732 875 943 954">Bit rate (Gbit/s)</th> <th data-bbox="943 875 1208 954">Standard Name</th> <th data-bbox="1208 875 1441 954">Bit rate (Gbit/s)</th> </tr> </thead> <tbody> <tr> <td data-bbox="488 954 732 992">Variable</td> <td data-bbox="732 954 943 992">24.3 to 28.2*⁷</td> <td data-bbox="943 954 1208 992">Variable</td> <td data-bbox="1208 954 1441 992">24.3 to 28.2, 9.5 to 14.2*⁷</td> </tr> <tr> <td data-bbox="488 992 732 1028">32GFC</td> <td data-bbox="732 992 943 1028">28.05</td> <td data-bbox="943 992 1208 1028">32GFC</td> <td data-bbox="1208 992 1441 1028">28.05</td> </tr> <tr> <td data-bbox="488 1028 732 1064">InfiniBand EDR</td> <td data-bbox="732 1028 943 1064">25.78125</td> <td data-bbox="943 1028 1208 1064">InfiniBand EDR</td> <td data-bbox="1208 1028 1441 1064">25.78125</td> </tr> <tr> <td data-bbox="488 1064 732 1099">100GbE/4</td> <td data-bbox="732 1064 943 1099">25.78125</td> <td data-bbox="943 1064 1208 1099">100GbE/4</td> <td data-bbox="1208 1064 1441 1099">25.78125</td> </tr> <tr> <td data-bbox="488 1099 732 1135">100GbE/4 FEC</td> <td data-bbox="732 1099 943 1135">27.7393</td> <td data-bbox="943 1099 1208 1135">100GbE/4 FEC</td> <td data-bbox="1208 1099 1441 1135">27.7393</td> </tr> <tr> <td data-bbox="488 1135 732 1171">OTU4</td> <td data-bbox="732 1135 943 1171">27.952493</td> <td data-bbox="943 1135 1208 1171">OTU4</td> <td data-bbox="1208 1135 1441 1171">27.952493</td> </tr> <tr> <td></td> <td></td> <td data-bbox="943 1171 1208 1207">10GFC</td> <td data-bbox="1208 1171 1441 1207">10.51875</td> </tr> <tr> <td></td> <td></td> <td data-bbox="943 1207 1208 1243">10GFC FEC</td> <td data-bbox="1208 1207 1441 1243">11.3168</td> </tr> <tr> <td></td> <td></td> <td data-bbox="943 1243 1208 1279">16GFC</td> <td data-bbox="1208 1243 1441 1279">14.025</td> </tr> <tr> <td></td> <td></td> <td data-bbox="943 1279 1208 1314">InfiniBand x4</td> <td data-bbox="1208 1279 1441 1314">10</td> </tr> <tr> <td></td> <td></td> <td data-bbox="943 1314 1208 1350">InfiniBand FDR</td> <td data-bbox="1208 1314 1441 1350">14.0625</td> </tr> <tr> <td></td> <td></td> <td data-bbox="943 1350 1208 1386">10GbE WAN/PHY</td> <td data-bbox="1208 1350 1441 1386">9.95328</td> </tr> <tr> <td></td> <td></td> <td data-bbox="943 1386 1208 1422">10GbE LAN/PHY</td> <td data-bbox="1208 1386 1441 1422">10.3125</td> </tr> <tr> <td></td> <td></td> <td data-bbox="943 1422 1208 1458">OTU1e (10GbE FEC)</td> <td data-bbox="1208 1422 1441 1458">11.049107</td> </tr> <tr> <td></td> <td></td> <td data-bbox="943 1458 1208 1494">OTU2e (10GbE FEC)</td> <td data-bbox="1208 1458 1441 1494">11.095728</td> </tr> <tr> <td></td> <td></td> <td data-bbox="943 1494 1208 1529">OC-192/STM-64</td> <td data-bbox="1208 1494 1441 1529">9.95328</td> </tr> <tr> <td></td> <td></td> <td data-bbox="943 1529 1208 1565">OC-192/STM-64 FEC (G.975)</td> <td data-bbox="1208 1529 1441 1565">10.664228</td> </tr> <tr> <td></td> <td></td> <td data-bbox="943 1565 1208 1601">OTU2</td> <td data-bbox="1208 1565 1441 1601">10.709225</td> </tr> </tbody> </table>				Without MP2110A-x93		With MP2110A-x93		Standard Name	Bit rate (Gbit/s)	Standard Name	Bit rate (Gbit/s)	Variable	24.3 to 28.2* ⁷	Variable	24.3 to 28.2, 9.5 to 14.2* ⁷	32GFC	28.05	32GFC	28.05	InfiniBand EDR	25.78125	InfiniBand EDR	25.78125	100GbE/4	25.78125	100GbE/4	25.78125	100GbE/4 FEC	27.7393	100GbE/4 FEC	27.7393	OTU4	27.952493	OTU4	27.952493			10GFC	10.51875			10GFC FEC	11.3168			16GFC	14.025			InfiniBand x4	10			InfiniBand FDR	14.0625			10GbE WAN/PHY	9.95328			10GbE LAN/PHY	10.3125			OTU1e (10GbE FEC)	11.049107			OTU2e (10GbE FEC)	11.095728			OC-192/STM-64	9.95328			OC-192/STM-64 FEC (G.975)	10.664228			OTU2	10.709225
Without MP2110A-x93		With MP2110A-x93																																																																																		
Standard Name	Bit rate (Gbit/s)	Standard Name	Bit rate (Gbit/s)																																																																																	
Variable	24.3 to 28.2* ⁷	Variable	24.3 to 28.2, 9.5 to 14.2* ⁷																																																																																	
32GFC	28.05	32GFC	28.05																																																																																	
InfiniBand EDR	25.78125	InfiniBand EDR	25.78125																																																																																	
100GbE/4	25.78125	100GbE/4	25.78125																																																																																	
100GbE/4 FEC	27.7393	100GbE/4 FEC	27.7393																																																																																	
OTU4	27.952493	OTU4	27.952493																																																																																	
		10GFC	10.51875																																																																																	
		10GFC FEC	11.3168																																																																																	
		16GFC	14.025																																																																																	
		InfiniBand x4	10																																																																																	
		InfiniBand FDR	14.0625																																																																																	
		10GbE WAN/PHY	9.95328																																																																																	
		10GbE LAN/PHY	10.3125																																																																																	
		OTU1e (10GbE FEC)	11.049107																																																																																	
		OTU2e (10GbE FEC)	11.095728																																																																																	
		OC-192/STM-64	9.95328																																																																																	
		OC-192/STM-64 FEC (G.975)	10.664228																																																																																	
		OTU2	10.709225																																																																																	

*5: It is output when Test Pattern is PRBS and 1/16Clock Pattern and it is not output when Test Pattern is 1/2Clock Pattern.

*6: Only when MP2110A-x14

*7: The bit rate can be specified in 1 kbit/s steps.

A.2.2 Pulse Pattern Generator

Table A.2.2-1 PPG

Item	Specifications																							
Data Output*1																								
Number of output	MP2110A-x11:	1	(Data Out, $\overline{\text{Data}}$ Out)*2																					
	MP2110A-x12:	2	(Data Out, $\overline{\text{Data}}$ Out)*2																					
	MP2110A-x14:	4	(Data Out, $\overline{\text{Data}}$ Out)*2																					
Amplitude																								
Range	0.1 to 0.8 Vp-p / 0.01 V resolution (Single-ended) 0.2 to 1.6 Vp-p / 0.02 V resolution (Differential)																							
Accuracy	± 20 mV $\pm 20\%$ for settings*3																							
Data Crossing	50%																							
Accuracy	$\pm 10\%$ *3,*4																							
Tr/Tf	typ. 15 ps*3,*4 (20-80%) max. 17 ps*3,*4 (20-80%)																							
Jitter	<table border="1"> <thead> <tr> <th></th> <th colspan="2">MP2110A-x11, MP2110A-x12</th> <th colspan="2">MP2110A-x14</th> </tr> <tr> <th></th> <th>typ.</th> <th>max.</th> <th>typ.</th> <th>max.</th> </tr> </thead> <tbody> <tr> <td>Jitter (RMS) *3,*4,*5,*6</td> <td>600 fs</td> <td>900 fs</td> <td>600 fs*8, 900 fs*9</td> <td>900 fs*8, 1200 fs*9</td> </tr> <tr> <td>Intrinsic RJ (RMS) *3,*4,*5,*7</td> <td>400 fs</td> <td>600 fs</td> <td>400 fs*8, 800 fs*9</td> <td>600 fs*8, 1000 fs*9</td> </tr> </tbody> </table>					MP2110A-x11, MP2110A-x12		MP2110A-x14			typ.	max.	typ.	max.	Jitter (RMS) *3,*4,*5,*6	600 fs	900 fs	600 fs*8, 900 fs*9	900 fs*8, 1200 fs*9	Intrinsic RJ (RMS) *3,*4,*5,*7	400 fs	600 fs	400 fs*8, 800 fs*9	600 fs*8, 1000 fs*9
	MP2110A-x11, MP2110A-x12		MP2110A-x14																					
	typ.	max.	typ.	max.																				
Jitter (RMS) *3,*4,*5,*6	600 fs	900 fs	600 fs*8, 900 fs*9	900 fs*8, 1200 fs*9																				
Intrinsic RJ (RMS) *3,*4,*5,*7	400 fs	600 fs	400 fs*8, 800 fs*9	600 fs*8, 1000 fs*9																				
Output ON/OFF	ON/OFF switching																							
Data/XData Skew	± 8 ps max.*3,*4																							
Connector	K Connector (f)																							
Data Format	NRZ																							
Test Pattern	PRBS:	2 ⁷ -1, 2 ⁹ -1, 2 ¹⁵ -1, 2 ²³ -1, 2 ³¹ -1																						
	Auxiliary pattern:	1/2 Clock Pattern, 1/16 Clock Pattern																						
Pattern Invert	ON/OFF																							
External ATT Factor	0 to 30 dB, 1 dB resolution Able to display the relative value of Data output and $\overline{\text{Data}}$ output.																							
Error Addition	Single																							

*1: These are measured in the MP2110A sampling oscilloscope (with MP2110A-x24).

The clock output is used for the external trigger (Trigger) of the sampling oscilloscope.

*2: These can be output separately.

*3: When bit rate is set to 25.78125 Gbit/s.

*4: When amplitude is set to 0.3 Vp-p.

*5: These are measured in 25 \pm 5 degree Celsius.

*6: Test pattern is PRBS 2³¹-1.

*7: Test pattern is 1/16 Clock Pattern.

- *8: Selecting Clock Source to Ch1/2 when measuring Ch1 and Ch2, Selecting Clock Source to Ch3/4 when measuring Ch3 and Ch4.
- *9: Selecting Clock Source to Ch3/4 when measuring Ch1 and Ch2, Selecting Clock Source to Ch1/2 when measuring Ch3 and Ch4.

A.2.3 Error Detector

Table A.2.3-1 ED

Item	Specifications
Data Input	
Number of Input	MP2110A-x11: 1 (Data, $\overline{\text{Data}}$) (Single-ended, differential input) MP2110A-x12: 2 (Data, $\overline{\text{Data}}$) (Single-ended, differential input) MP2110A-x14: 4 (Data, $\overline{\text{Data}}$) (Single-ended, differential input)
Data Format	NRZ, Mark ratio 50%, Single-ended or differential input
Amplitude	0.05 to 0.8 Vp-p
Termination	50 Ω, AC coupled (DC component is terminated to the GND through a resistance of 50 Ω.)
Threshold	-0.085 to +0.085 V*1, 1 mV resolution
Sensitivity	25 mVp-p*2,*3, typ. (25±5°C) 40 mVp-p*2,*3, max.
Connector	K Connector (f)
Jitter Tolerance*2,*4	Sinusoidal jitter amplitude

- *1: Guaranteed under the following conditions:
 - Single-ended
 - External attenuator factor 0 dB
- *2: Guaranteed under the following conditions:
 - Bit rate: 25.78125 Gbit/s
 - Pattern: PRBS2^31-1
 - Single-ended
- *3: Guaranteed under the following conditions:
 - Mark ratio 1/2
 - Loop-back connection
- *4: Amplitude: 50 mV

Table A.2.3-1 ED (Cont'd)

Item	Specifications
External ATT factor	0 to 30 dB*5, 1 dB resolution
Test Pattern	PRBS: 2 ⁷ -1, 2 ⁹ -1, 2 ¹⁵ -1, 2 ²³ -1, 2 ³¹ -1 Logic invertible
Measurement	
Alarm Detection	Sync loss*6
Bit Error Detection	Total Error Rate: 0.0001E-18 to 1.0000E-03 Total Error Count: 0 to 9999999, 1.0000E07 to 9.9999E17
Recovered Clock Detection	Able to detect the input signal frequency (sampling system).
History	Sync loss, Bit error (able to reset the history indicator)
Gate settings	
Gating Unit	1 seconds to 9 days 23 hours 59 minutes 59 seconds
Cycle	Single / Repeat / Untimed
Current	Able to switch On or Off. (When it is Off, the result is updated after set time is passed)
Result Time	Start Time, Elapsed Time, Remaining Time
Progress Bar	Displays the measurement progress in a bar graph and percent figures.
PPG/ED Tracking	Test Pattern

*5: The thresholds corrected by the external attenuation factor are displayed. The formulas are shown below:

$$\text{Upper limit value} = -85 \times 10^{\left(\frac{\text{ATT}}{20}\right)}$$

$$\text{Lower limit value} = 85 \times 10^{\left(\frac{\text{ATT}}{20}\right)}$$

$$\text{Resolution} = 1.0 \times 10^{\left(\frac{\text{ATT}}{20}\right)}$$

*6: It is not synchronizing with Test Pattern.

A.3 Sampling Oscilloscope

A.3.1 Channel Configuration

Table A.3.1-1 Channel Configuration

Option Number	Ch A	Ch B	Ch C	Ch D
MP2110A-x21	Electrical channel	Electrical channel	None	None
MP2110A-x22, MP2110A-x32, MP2110A-x42	Optical channel	Optical channel	None	None
MP2110A-x23, MP2110A-x33, MP2110A-x43	Electrical channel	Optical channel	None	None
MP2110A-x25, MP2110A-x35, MP2110A-x45	None	SMF Input Optical channel *1	None	None
MP2110A-x26, MP2110A-x36, MP2110A-x46	None	MMF Input Optical channel *2	None	None
MP2110A-x30, MP2110A-x40	SMF Input Optical channel*1	SMF Input Optical channel*1	SMF Input Optical channel*1	SMF Input Optical channel*1
MP2110A-x39, MP2110A-x49	MMF Input Optical channel*2	MMF Input Optical channel*2	MMF Input Optical channel*2	MMF Input Optical channel*2

*1: No MMF Input

*2: No SMF Input

A.3.2 Common Performances

Table A.3.2-1 Common Functions and Performances

Item	Specifications	
Sampling System		
Sampling Mode	Eye, Pulse, Coherent Eye, Advanced Jitter*1	
Test Pattern*2	Without MP2110A-x95/x98	With MP2110A-x95 or MP2110A-x98*3
	Variable	Variable, PRBS2 ⁷⁻¹ (127 symbols)*4, PRBS2 ⁹⁻¹ (511 symbols)*4, PRBS2 ¹¹⁻¹ (2047 symbols)*4, PRBS2 ¹³⁻¹ (8191 symbols)*4, PRBS2 ¹⁵⁻¹ (32767 symbols)*4, SSPRQ (65535 symbols)*4

*1: Available when MP2110A-x96 is installed

*2: Trigger division ratio operates at 1, 2, 4, 8, 16, 32, 40, 48 or 64

*3: Possible to analyze the following patterns with Pulse/Coherent Eye (Impossible to analyze with Variable)

PRBS2⁷⁻¹ (127 symbols), PRBS2⁹⁻¹ (511 symbols), PRBS2¹¹⁻¹ (2047 symbols), PRBS2¹³⁻¹ (8191 symbols), PRBS2¹⁵⁻¹ (32767 symbols), SSPRQ (65535 symbols)

*4: Operation is guaranteed at Symbol Rate of 9.95 Gbaud to 60 Gbaud.
Possible to analyze when Symbol Length is same

Table A.3.2-1 Common Functions and Performances (Cont'd)

Item	Specifications
Number of Samples	Number of samples on one screen <Eye>: 1350, 2048, 4050 <Pulse, Coherent Eye>: 512, 1024, 2048, 4096, 8192, 16384*5
Sampling	Run: Execute sampling Hold: Stop sampling
Display	Ch A: ON/OFF, Ch B: ON/OFF, Ch C: ON/OFF, Ch D: ON/OFF
Accumulation Type	Waveform display method None: Display with no accumulation Infinite: Display with infinite accumulation Limited: Display with accumulation up to the specified sample number, time, or number of waveforms Persistency: Display with afterglow indication for the specified time Averaging: Display by averaging the specified number of waveforms (For compatibility) Averaging can be selected only when Sampling Mode is Pulse When Sampling Mode is Advanced Jitter, only Infinite, Limited can be selected
Limit Type	Specifies cumulative completion condition when Accumulation Type is set to Limited Time: Measurement stops when the cumulative time exceeds the set time Sample: Measurement stops when the total cumulative number of samples exceeds the set number of samples. Waveform: Measurement stops when the total waveform sweep count exceeds the set sweep count. Pattern*6: Measurement stops if the total acquisition pattern count exceeds the set sweep count.
Averaging	When set to On , averaging is performed. This is available when one of the following conditions is met: • Sampling mode is Pulse • Sampling mode is Coherent Eye , and Test Pattern is other than Variable
Clear Display	Clears display drawing
Auto Scale	Sets Time Scale and Amplitude to optimum values automatically
Auto Scale + Calculate + Sampling*7	Performs Calculate for Auto Scale and Reference Equalizer, and then sets Sampling to Run . When Calculate fails, Sampling is not set to Run . When Accumulation Type is Limited and Limit Type is Pattern, the data for only the set pattern is collected and the result is displayed.

*5: Fixed to 16384 when Coherent Eye and Test Pattern are set

*6: Not available when Sampling Mode is **Eye**

*7: Displayed only when MP2110A-x95 is installed

A.3.3 Time Setting

Table A.3.3-1 Time Setting

Item	Specifications
Recalculate Option	Specifies the reference parameter Symbol Rate (Symbol Rate is automatically set when Clock Rate is entered) Clock Rate (Clock Rate is automatically set when Symbol Rate is entered)
Symbol Rate	Specifies the baud rate of the signal input to the Scope channel 100 Mbaud to 60 Gbaud, 1 kbaud step
Clock Rate	Specifies the clock frequency input to Trigger In 100 MHz to 15 GHz, 1 kHz step
Tracking	Function that sets Symbol Rate and Divide Ratio to values set by other options, when BERT or Clock Recovery option is installed
Acquire Clock Rate	Updates Clock Rate by measuring the clock rate input to Trigger In (Data Rate is automatically set according to the Divide Ratio)
Divide Ratio	Ratio of Clock and Input Data (1 to 99. However, Pulse / Coherent Eye Mode works only when setting 1, 2, 4, 8, 16, 32, 40, 48, 64)* ¹
Divide Ratio Detect	Detects Divide Ratio automatically
Precision Trigger* ² Enable Reset Alarm	ON/OFF (Trigger Clock ON is possible at input frequency of 2.4 GHz or higher) Ability to redetect the internal correction value for Precision Trigger Ability to display status to the user when the internal correction value becomes inappropriate
Scale/Offset Unit UI On Screen Offset	Specifies the horizontal axis unit of the screen UI, Time(ps) Specifies the number of UI on the screen Eye, Coherent Eye Mode: 1 to 100 UI (1 UI step) Pulse Mode: 1 to 65535 UI (1 UI step) Sets time offset for trigger position 0.00 to 32768.00 UI (0.01 UI step) Available only when Sampling Mode is Pulse.
Software Delay	Function of correcting Inter-channel phase delay Channel A: $\pm \frac{\text{UI On Screen}}{2}$ Display UI converted to ps (0.1 ps step) Channel B: $\pm \frac{\text{UI On Screen}}{2}$ Display UI converted to ps (0.1 ps step) Channel C: $\pm \frac{\text{UI On Screen}}{2}$ Display UI converted to ps (0.1 ps step) Channel D: $\pm \frac{\text{UI On Screen}}{2}$ Display UI converted to ps (0.1 ps step)

*1: 48 is supported by Version 6 or later.

*2: Available when MP2110A-x24 is installed

Table A.3.3-1 Time Setting (Cont'd)

Item	Specifications
Pattern Length Tracking	Specifies capturing pattern length when using Pulse, Coherent Eye Mode BERT option is required*3. Tracks the Pattern length setting of BERT. PPG Ch1, PPG Ch2, PPG Ch3, PPG Ch4, ED Ch1, ED Ch2, ED Ch3, ED Ch4
Manual	Settable when Test Pattern in Table A.3.2-1 is Variable. Specifies the pattern length manually 2 to 32768 UI

*3: When Test Pattern in Table A.3.2-1 is set to anything other than Variable, it cannot be set

A.3.4 Measurement

Table A.3.4-1 Measurement

Item	Specifications
Signal Type	Specifies the signal type of the target channel NRZ, PAM4*
Active Channel	Selects one channel among Ch A, Ch B, Ch C and Ch D.
Marker	X1: ON/OFF, X2: ON/OFF Y1: ON/OFF, Y2: ON/OFF

*: PAM4 is selectable when MP2110A-x95 is installed

Table A.3.4-2 Amplitude/Time Measurement

Item	Specifications
Measurement Select	<p>For channels with Signal Type set to NRZ, the following items can be measured</p> <p>One Level, Zero Level, Eye Amplitude, Eye Height, Eye Height (Ratio), Crossing, SNR, Average Power (dBm)*1, Average Power (mW)*1, Extinction Ratio*1, Jitter p-p, Jitter RMS, Rise Time, Fall Time, Eye Width, DCD, OMA (dBm)*1, OMA (mW)*2, *3, *4, VECP*2, OMA at Crossing*2, *3, *4, TDEC*2, RIN OMA*1, *4, *5, Crossing Time, Amplitude P-P</p> <p>For channels with Signal Type set to PAM4, the following items can be measured</p> <p>TDECQ*2, *5, Outer OMA*2, *3, *4, Outer ExR*1, Linearity, Ceq*2, Partial TDECQ*2, *5, Levels (Level 3, Level 2, Level 1, Level 0) , Levels RMS (Level 3, Level 2, Level 1, Level 0) , Levels P-P (Level 3, Level 2, Level 1, Level 0) , Level Skews (Level 3, Level 2, Level 1, Level 0), Eye Levels (Upper, Middle, Lower), Eye Skews (Upper, Middle, Lower), Eye Heights (Upper, Middle, Lower), Eye Widths (Upper, Middle, Lower), Average Power (dBm)*1, Average Power (mW)*1, RIN OMA*1, *5, Transition Time (Rise/Fall)*2, *5, Transition Time (Slow)*2, *5, Over/Under-shoot*2, P-P Power*1</p> <p>Power Excursion*1, Noise Margin*2, *5, Partial Noise Margin*2, *5</p> <p>When MP2110A-x96 is installed on the channel whose Signal Type is NRZ, the following items can be measured *7</p> <p>TJ (User Define)*6, RJ (d-d) , DJ (d-d) , J2 Jitter, J4 Jitter, J9 Jitter, Eye Opening*6, RJ (rms)*7, PJ (p-p)*7, DDJ (p-p)*7, DCD*7, ISI (p-p) *7, DDPWS*7, PJ Frequency*7, *8</p>
Item Selection	<p>Selects up to 4 or 32 items from Measurement Select and displays the result *9</p>
Measuring Area Marker	<p>Channel, Current Value, Average, Std.Dev, Min, Max</p> <p>Displays the measurement area as a marker</p>

- *1: When optical input channel is selected
- *2: For Version 7.02 or earlier, when an optical channel is selected. For newer than it, both electric and optical channels are supported.
- *3: For electrical channels, the unit is mV.
- *4: For electrical channels, OMA is replaced by VMA.
- *5: Can be measured when Sampling Mode is Coherent Eye and Test Pattern is other than Variable.
- *6: BER specified in TJ Measurement BER in the setting items
- *7: Can be measured when Sampling Mode is Advanced Jitter.
- *8: Impossible to measure with differential signals
- *9: Items 1 to 4 are available with Version 5. Items 1 to 32 are available with Version 6 or later.

Table A.3.4-2 Amplitude/Time Measurement (Cont'd)

Item	Specifications
NRZ Measure Setup	Setup items for measuring NRZ
Eye Boundary	Offset from Crossing: 0 to 1 UI (0.01 UI step)
	Width: 0 to 1 UI (0.01UI step)
Rise/Fall Time	Percentage: 10-90%, 20-80%
	Correction Factor: 0 to 9999.9 ps
	(Correct actual Tr / Tf when inserting LPF)
Noise Measure Area	Sets the position to measure noises of SNR.
	Zero Level + One Level
	Zero Level
	One Level
PAM4 Measure Setup	Setup items for measuring PAM4*10
Sample Timing	“Track to Middle EyeTiming”:
	The phase of Middle EYE is the reference
Eye Center Type	“Independent Timing”:
	The phases of Upper, Middle and Lower are independent reference in each other.
	“Maximum Eye Width”:
	The center of the eye opening at the amplitude where the Eye Width is the maximum is the reference.
	“Maximum Eye Height”:
	The phase where Eye Height becomes maximum is the reference.
Peak Power Hit Ratio	Sets the threshold for determining the Peak Power by the ratio to the number of samples in 1 UI.
	Pmax (Maximum Power): Position of the ratio specified to the number of samples from the maximum value of the waveform
	Pmin (Minimum Power): Position of the ratio specified to the number of samples from the minimum value of the waveform
	Peak Power: Difference between Pmax and Pmin
	If 0 is specified, the difference between maximum and minimum values of the waveform is considered Peak Power.
Eye Opening Definition	“Zero Hits”:
	The value at which the Eye opening becomes the largest in the sample evaluation is measured.
	“1E-01 to 1E-06”:
	Error rate is set in step of 1E+01, The measurement result is calculated at the specified error rate.
Linearity Definition	Sets the definition of the Linearity measurement method.
	IEEE Clause 94
	IEEE Annex 120D
Target SER	Sets the SER (Symbol Error Rate) to be used when measuring TDECQ.
	Range: 9.99E-06 to 1.00E-01
	* This can be set from the IEEE or FC standard.
Optimize Threshold	Sets whether to optimize the threshold for measuring TDECQ as specified in the IEEE 802.3cd.
Optimize TDECQ Histogram	Sets whether to use the function that improves the reproducibility of TDECQ measurement.
Noise Coefficient	Sets the retaining amount of noise aliased by the digital filter.

*10: Available when MP2110A-x95 is installed.

Table A.3.4-3 Jitter Measurement

Item	Specifications																																																															
Jitter Measure Setup	Settings related to jitter measurement items*																																																															
TJ Measurement BER	Sets the BER to measure TJ(User Define) and Eye Opening with the measurement result. Selectable up to 1.0E-001 to 1.0E-018, in 1.0E+001 Step																																																															
Fixed RJ	Function to use User-specified value for RJ results “ON”: Uses the value of Fixed RJ Factor “OFF”: Uses the calculation result for jitter categorizing.																																																															
RJ Value	The value to be used when Fixed RJ is ON 0.01 to 999.99 ps, step 0.01 ps rms																																																															
Correction Factor	Function to correct results by Users “ON”: Corrects the result. “OFF”: Does not correct the result.																																																															
DJ (Scale)	Function to adjust Scale of DJ $DJ = DJ (Scale) \times \text{Measurement result}$ 0.01 to 999.99, step 0.01																																																															
RJ (Scale)	Function to adjust Scale of RJ $RJ = RJ (Scale) \times \text{Measurement result}$ 0.01 to 999.99, step 0.01																																																															
RJ (rms)	Function to adjust rms of RJ $RJ = \sqrt{(\text{Measurement result})^2 - \{RJ(\text{rms})\}^2}$ 0.01 to 999.99 ps rms, step 0.01 ps rms																																																															
Define Threshold	Definition of Crossing value to measure jitter Auto: Automatic adjustment with the use of Crossing value of Scope Manual: User input of Crossing to be measured																																																															
Manual Crossing	Crossing value to measure jitter 30 to 70%, step 1%																																																															
PDJ Measurement	Function to switch Pattern Dependent Jitter measurement method. Available at Advanced Jitter. “ON”: Displays the result to regard DDJ as PDJ. “OFF”: Displays the result to regard DDJ as DDJ.																																																															
PDJ Standard Filter	When PDJ Measurement is ON, the following filters are used for PDJ measurement depending on the Standard. Unit is Hz.																																																															
	<table border="1"> <thead> <tr> <th>Standard</th> <th>HP0</th> <th>HP1</th> <th>HP1'</th> <th>HP2</th> <th>HP'</th> <th>HP</th> <th>LP</th> <th>LP'</th> </tr> </thead> <tbody> <tr> <td>STM-0</td> <td>10</td> <td>100</td> <td>–</td> <td>20 k</td> <td>–</td> <td>12 k</td> <td>400 k</td> <td>–</td> </tr> <tr> <td>STM-1</td> <td>10</td> <td>500</td> <td>–</td> <td>65 k</td> <td>–</td> <td>12 k</td> <td>1.3 M</td> <td>500</td> </tr> <tr> <td>STM-4</td> <td>10</td> <td>1 k</td> <td>–</td> <td>250 k</td> <td>–</td> <td>12 k</td> <td>5 M</td> <td>1 k</td> </tr> <tr> <td>STM-16</td> <td>10</td> <td>5 k</td> <td>–</td> <td>1 M</td> <td>–</td> <td>12 k</td> <td>20 M</td> <td>5 k</td> </tr> <tr> <td>STM-64</td> <td>10</td> <td>20 k</td> <td>10 k</td> <td>4 M</td> <td>50 k</td> <td>12 k</td> <td>80 M</td> <td>20 k</td> </tr> <tr> <td>STM-256</td> <td>–</td> <td>80 k</td> <td>20 k</td> <td>16 M</td> <td>–</td> <td>–</td> <td>320 M</td> <td>–</td> </tr> </tbody> </table>	Standard	HP0	HP1	HP1'	HP2	HP'	HP	LP	LP'	STM-0	10	100	–	20 k	–	12 k	400 k	–	STM-1	10	500	–	65 k	–	12 k	1.3 M	500	STM-4	10	1 k	–	250 k	–	12 k	5 M	1 k	STM-16	10	5 k	–	1 M	–	12 k	20 M	5 k	STM-64	10	20 k	10 k	4 M	50 k	12 k	80 M	20 k	STM-256	–	80 k	20 k	16 M	–	–	320 M	–
Standard	HP0	HP1	HP1'	HP2	HP'	HP	LP	LP'																																																								
STM-0	10	100	–	20 k	–	12 k	400 k	–																																																								
STM-1	10	500	–	65 k	–	12 k	1.3 M	500																																																								
STM-4	10	1 k	–	250 k	–	12 k	5 M	1 k																																																								
STM-16	10	5 k	–	1 M	–	12 k	20 M	5 k																																																								
STM-64	10	20 k	10 k	4 M	50 k	12 k	80 M	20 k																																																								
STM-256	–	80 k	20 k	16 M	–	–	320 M	–																																																								
Measurement Edge Type	Switching of Edge to measure jitter Available at Advanced Jitter. “ALL”: Measures both rising and falling transition. “Rising”: Measures only rising transition. “Falling”: Measures only falling transition. Depending on this setting, the result on the graph also displays the corresponding transition result.																																																															

*: Available when MP2110A-x96 is installed.

Table A.3.4-4 Histogram

Item	Specifications
Histogram	Setting functions related to the Histogram measurement
Target Channel	ON, OFF Measures the Active Channel
Axis	Amplitude, Time
Marker	X1, X2, Y1, Y2
Result Display	Mean, Std. Dev, p-p, Hits

Table A.3.4-5 Mask Test

Item	Specifications
Mask Test	Setting functions related to the Mask Test measurement
Target Channel	Turns on and off by channel.
Compliance Mask	Selects the Mask to be used for measurement from files.
Mask Margin Test Method	One Shot Continuous
Align Method	Function to specify the method to set Mask position.
Auto Align	Zero/One/Crossing
User Defined	Alignment Marker X1, ΔX, Y1, ΔY
Alignment Marker	Display On/ Display Off
Mask Margin	-100 to +100%
Margin Type	Selects from Hit Count or Hit Ratio.
Hit Count	1 to 999999999*1
Hit Ratio	1E-12 to 9E-01*2
Mask Area Restriction	ON/OFF Function to limit Mask effective area in Mask measurement
Angle	-90 to 90° (1° step)
Width	0.01 to 1 UI (0.01 step)
Result Display	Total Samples, Total Waveforms, Mask Margin [%], Hit Count, Total Failed Samples, Top Mask Failed Samples, Center Mask Failed Samples, Bottom Mask Failed Samples

*1: Fail Sample upper limit value for Margin measurement

*2: Hit Count is automatically set with the total sample and set probability.

Table A.3.4-6 Equalizer*1

Item	Specifications
Display Equalized Waveform	“ON”: Displays the waveform after Reference Equalizer process. “OFF”: Displays the waveform before the Reference Equalizer process.
De-embedding Mode Flip S-parameter 4 Port Numbering Antialiasing Filter	Setting functions related to Embedding / De-embedding processing of waveforms*2 Supported file formats are s2p and s4p. Up to three De-embedding settings can be made. “Embedding”: Performs equalizer processing that adds s2p/s4p data characteristics. “De-embedding”: Performs equalizer processing that removes s2p/s4p data characteristics. Settings related to port definition of S-Parameter. When set to ON, S12 is used as a transmission characteristic. Settings related to port definition for loading an s4p file. Input port can be selected from Port1/2 or Port1/3. “ON”: Applies Antialiasing Filter to the band outside the frequency range described in the s2p / s4p file. “OFF”: Does not apply Antialiasing Filter to the band outside the frequency range described in the s2p / s4p file.
CTLE File	Setting functions related to CTLE processing specified by IEEE and CEI.*3 Function for loading a CTLE configuration file.
FFE Equalizer Type Equalizer Tap Optimization Number of Precursors	Setting functions related to FFE processing.*4 Set the equalizer type to automatically calculate the Tap for Reference Equalizer. “TDECQ”: Calculates the Tap coefficient that optimizes TDECQ. “Linear”: Calculates the Tap coefficient that increases the eye opening. “Calculate”: Executes the calculation for Tap optimization. After the calculation, whether the calculation was completed normally is indicated in the item of Status. “Tap Count”: The number of Taps for the Reference Equalizer. It can be set in the range of 3 to 21. “Taps”: The number of Taps for the Reference Equalizer. The number is settable up to 6 decimal places. “Status”: The flag which indicates whether the last calculation was completed successfully. Selects an algorithm to optimize taps. “Fast”: Low optimization level but faster calculation “Auto”: High optimization level but slower calculation. This function is available when the Optimization is set to “Fast”. Range: 0 to (Tap Counts–1)

*1: Settings for the Equalizer function that works when Sampling Mode is set to Coherent Eye and Test Pattern is other than Variable.

*2: For electrical channel, it can be set only when the MP2110A-x98 is installed.

For optical channel, it can be set only when the MP2110A-x95 or MP2110A-x98 is installed.

*3: Can be set only when the MP2110A-x98 is installed.

*4: Can be set only when the MP2110A-x95 is installed.

A.3.5 Utilities

Table A.3.5-1 Utilities

Item	Specifications
EYE/Pulse Shot	Saves Result screen image as jpg or png format image.
Inverse Background Color	Saves EYE / Pulse Shot waveform area with reversing the color.
Waveforms Only	Saves only the waveform display area in the Result screen.
Waveform Color	Selects the gradation table of the waveform at the time of cumulative setting. Option: Color Grade, Gray Scale
Color Select	Selects a basic color when Waveform Color is set to “Gray Scale”. Option: Yellow, Blue, Green, Pink, Orange, Light Blue, Light Green, Red The color can be set separately for before and after adaptation of the TDECQ equalizer.
Mask Color	Selects the color of Mask displayed at Mask Test.
Preset Information	Displays or hides the preset information in the waveform display area.
Label Add Label Delete Label	Displays arbitrary character string on EYE / Pulse Scope screen. One label is displayed on one screen. The maximum number of characters is 1023 characters. Deletes the displaying label.
Trace Memory	Stores measurement waveform in internal memory.
Trace Memory	“Set”: Saves the waveform data of all displayed channels. “Clear”: Clears the saved waveform data.
Graph Display Mode	Switches the display mode. “Overlap”: Displays waveforms of all channels on a graph. “Single”: Displays the waveform of the active channel. “Tile”: Splits the graph area in quarters and displays waveforms of all channels in the separate split graph areas.
Control Ch	Switches the control channel mode. “All”: Applies changes to settings for all channels. “Single”: Changes settings for the active channel only. (Limited to some settings)

A.3.6 Maintenance

Table A.3.6-1 Calibration

Item	Specifications
Calibration	Calibrates Amplitude (Offset and linearity calibration) and O/E Module Calibration of dark current / current system
Application Test	Self-diagnostic function

A.3.7 Horizontal System

Table A.3.7-1 Horizontal System

Item	Specifications
Trigger Clk In Connector	SMA Connector (f.)
Termination	50 Ω, AC coupled
Trigger Clock Frequency	0.1 to 15.0 GHz When this item is set in the range of 2.4 to 15.0 GHz, the Precision Trigger function can be set to ON.
Trigger Clock Sensitivity	Typical 100 mVp-p, Max. 200 mVp-p*1 Typical 200 mVp-p*2
Maximum Amplitude	Min. 1.2 Vp-p
Maximum Amplitude (Before Damage)	2 Vp-p
Jitter, RMS	1.25 GHz or more, 15 GHz or less: Typical 0.4 ps, Max. 1.35 ps 0.1 GHz or more, less than 1.25 GHz: Typical 1.0 ps, Max. 1.5 ps 2.4 GHz or more, 15 GHz or less and when Precision Trigger is ON: Typical 200 fs*3,*4, Max. 280 fs*3 When MP2110A-x30, x39, x40 or x49 is installed 1.25 GHz or more, 15 GHz or less: Typical 350 fs, Max. 600 fs 0.1 GHz or more, less than 1.25 GHz: Typical 1.0 ps, Max. 1.5 ps

*1: It is specified by inputting the square wave when the trigger clock frequency is 1 GHz or less.

*2: When Precision Trigger is ON.

*3: Evaluation by connecting the sine wave output of the MG3695A or equivalent to the Trigger input.

*4: At 25±5°C

A.3.8 Digital System

Table A.3.8-1 Digital System

Item	Specifications
Sampling Speed	150 kSamples/s, Nominal
Effective Sampling Speed	250 kSamples/s, Nominal With Number of Sample = 1350, Symbol Rate = 25.78125 Gbaud, Clock Rate = 6.4453125 GHz, Eye Mode, UI on Screen = 2 UI
Process Speed	Effective process speed of Reference Equalizer Nominal 130 ksps @ 26.5625 Gbaud, Test Pattern = SSPRQ When setting Coherent Eye

A.3.9 Electrical Channel

Table A.3.9-1 Electrical Channel Function

Item	Specifications
Amplitude Setting	
Scale	Scale Setting on the vertical axis. Both ChA and ChB can be set as follows 1 to 200 mV/div, 0.1 mV step
Offset	Offset setting on the vertical axis. Both ChA and ChB can be set as follows -500 to 500 mV, 1 mV step
Attenuation	Function of correcting Amplitude Scale / Offset and measurement result in conjunction with the input attenuation of the attenuator connected to Data Input 0.00 to 30.00 dB, 0.01 dB step
Tracking*	Function to make the other channel track the active channel's Scale, Offset and Attenuation values. ON/OFF
Channel Math*	Function to draw calculation results of ChA and ChB
Channel Math Enable	ON/OFF
Define Function	Selects the calculation method ChA + ChB ChA - ChB ChB - ChA
Scale	Sets scale in Vertical Axis at displaying Channel Math calculation 1 to 200 mV/div, 0.1 mV step
Offset	Sets offset in Vertical Axis at displaying Channel Math calculation -1000 to 1000 mV, 0.1 mV step
Digital Filter	Corrects the frequency characteristics of the electrical channels to the 33 GHz or 40 GHz band by means of software processing Can be set only when Sampling Mode is set to Coherent Eye and Test Pattern is other than Variable.

*: Available when MP2110A-x21 is installed.

Table A.3.9-2 Electrical Channel Performance

Item	Specifications
Data Input Connector Termination Maximum Amplitude Dynamic Range Amplitude Accuracy	Electric Input Connector K Connector (f) 50 Ω, DC coupled ±2 V maximum input before damage ±400 mV* ¹ ±2% of reading ± offset amplitude accuracy (refer to below fig. * ² ,* ³)
Bandwidth (-3 dB) Flatness Noise RMS	Typical 40 GHz Typical ±1 dB (10 MHz to 30 GHz) Typical 1.5 mV Max. 2.5 mV

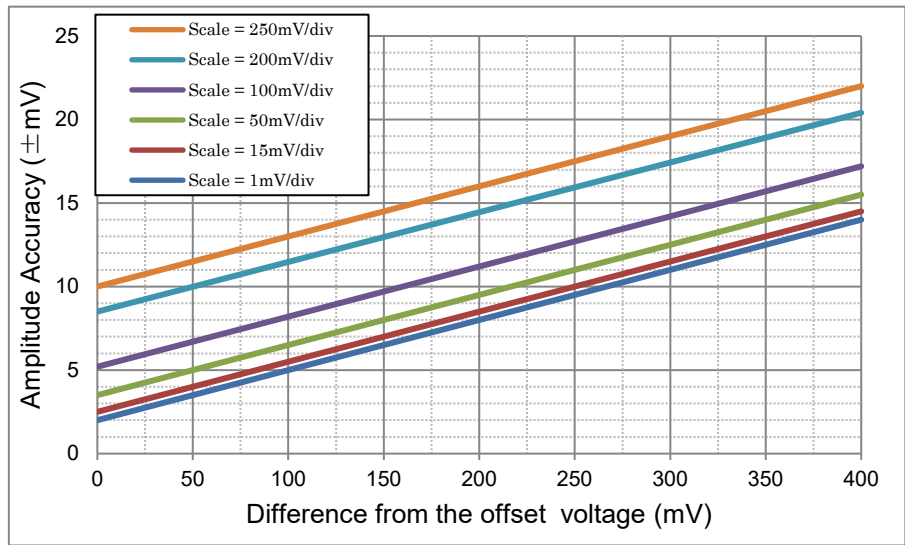

*1: Relative to amplitude offset

*2: After internal calibration

*3: Calculation example: At 400 mV amplitude reading value and 50 mV offset voltage

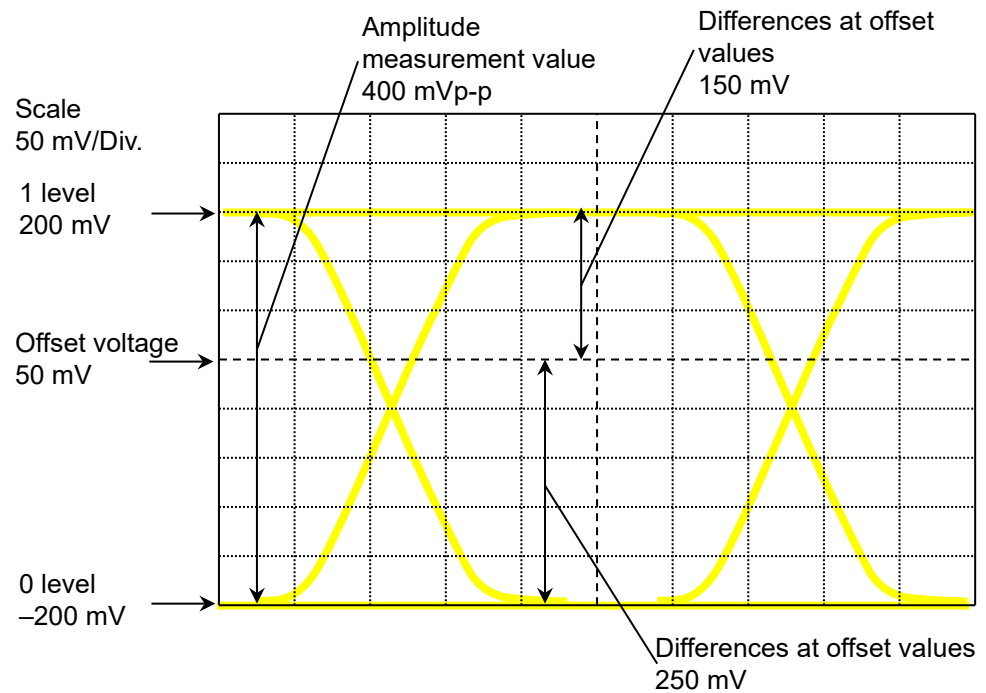

In this example, the difference between 1 level voltage (200 mV) and offset voltage (50 mV) is 150 mV. At a scale of 50 mV/div for a voltage difference of 150 mV, the amplitude accuracy is 8 mV. At 1 level accuracy, the difference is calculated as follows:

$$200 \times 2\% + 8 = 12 \quad \pm 12 \text{ mV}$$

The difference between 0 level voltage (-200 mV) and offset voltage (50 mV) is 250 mV. At the 50 mV/div scale for a voltage difference of 250 mV, the amplitude accuracy is 11 mV. At 0 level accuracy, the difference is calculated as follows:

$$200 \times 2\% + 11 = 15 \quad \pm 15 \text{ mV}$$

A.3.10 Optical Channel

Table A.3.10-1 Optical Channel Function

Item	Specifications
Amplitude Setting	
Scale	Scale setting on the vertical axis. 1 to 200 μ W /div, 1 μ W step
Offset	Offset setting on the vertical axis. Both ChA and ChB can be set as follows. -500 to 500 μ W, 1 μ W step
Attenuation	Function of correcting Amplitude Scale / Offset and measurement result in conjunction with the input attenuation of the attenuator connected to Data Input 0.00 to 30.00 dB, 0.01 dB step
Tracking*	Function to make the other channel track the active channel's Scale, Offset and Attenuation values. ON/OFF
Channel Math	Function not available
Filter Selection	Sets the bandwidth of O/E Input Port to No Filter or Reference Receiver compliant filters. Refer to Filter Response in Table A.3.10-2 for supported filters.
Extinction Ratio Correction	Extinction ratio correction function
Correction Enable	ON/OFF
Correction Factor	-9.99 to +9.99 %, 0.01% step
Conversion Gain	Adjusts two conversion gains. One is for SMF Input and the other is for MMF Input.
Responsivity	Adjusts two responsivities. One is for SMF Input and the other is for MMF Input.
Calibration	Conversion Gain / Responsivity Calibration, O/E Calibration

*: Available when MP2110A-x22, MP2110A-x30, MP2110A-x32, MP2110A-x39, MP2110A-x40, MP2110A-x42 or MP2110A-x49 is installed

Table A.3.10-2 Optical Channel Performance

Item	Specifications
Data Input Connector Fiber	Optical Input Connector Ch A, Ch B, Ch C, Ch D FC Connector (SMF Input, MMF Input) SMF Input:
Wavelength	62.5 μm GI Multimode fiber, accepts single mode fiber (When the installed option is other than MP2110A-x30 or x40) Singlemode fiber (When the installed option is MP2110A-x30 or x40) MMF Input: 62.5 μm GI Multimode fiber, accepts single mode fiber
Bandwidth (No Filter)	SMF Input: 860 to 1650 nm (When other than MP2110A-x30 and x40 is installed) 850 to 1650 nm (When MP2110A-x40 and x61 are installed) 1260 to 1650 nm (When MP2110A-x30 or x40 is installed) MMF Input: 800 to 860 nm
Filter Response	Typical 35 GHz (SMF Input) Typical 25 GHz (MMF Input) Supports the following specifications <NRZ standards> 100GbE/4 (25.78125 Gbit/s) 100GbE/4 FEC (27.7393 Gbit/s) OTU4 (27.952493 Gbit/s) 32GFC (28.05 Gbit/s) 10G LAN/PHY (10.3125 Gbit/s 7.5 GHz) [D] *1 10G WAN/PHY (9.95328 Gbit/s 7.46 GHz) [D] *1 <PAM4 standards>*1 400GbE/8 BiDi MMF (26.5625 Gbaud 8.96 GHz) [D] 400GbE/8 SMF (26.5625 Gbaud 13.3 GHz) [D] 400GbE/8 MMF (26.5625 Gbaud 12.6 GHz) [D] IEEE802.3cd Draft 2.0 400GbE/8 MMF (26.5625 Gbaud 11.2 GHz) [D] 400GbE/8 (26.5625 Gbaud 19.34 GHz) [D] 400GbE/4 SMF (53.125 Gbaud 26.5625 GHz)[D] 400GbE/4 SMF (53.125 Gbaud 38.7 GHz)[D] 400GbE/4 SMF (53.125 Gbaud 39.84 GHz)[D] 64GFC SMF (28.9 Gbaud 14.45 GHz) [D] 64GFC MMF (28.9 Gbaud 12.4 GHz) [D] 400GbE/8 MMF (26.5625 Gbaud 10.35 GHz) [D] (55.78125 Gbaud, 27.890625 GHz) [D] (56.666 Gbaud, 28.333 GHz) [D]

*1: When MP2110A-x95 or MP2110A-x98 is installed, Coherent Eye is set and Test pattern is set other than Variable

Table A.3.10-2 Optical Channel Performance (Cont'd)

Item	Specifications		
Optical Noise	When MP2110A-x22, x23, x25, x26, x32, x33, x35, x36, or x39 is installed:		
	Conditions	When MP2110A-x54 is not installed	When MP2110A-x54 is installed*2
	SMF Input, 1310 nm OTU4 Filter	Typ. 3.4 μ Wrms Max. 4.3 μ Wrms	Typ. 4.8 μ Wrms Max. 6.1 μ Wrms
	SMF Input, 1310 nm No Filter	Typ. 5.4 μ Wrms Max. 7.5 μ Wrms	Typ. 7.6 μ Wrms Max. 10.6 μ Wrms
	MMF Input, 850 nm OTU4 Filter	Typ. 6.7 μ Wrms Max. 8.4 μ Wrms	Typ. 9.5 μ Wrms Max. 11.9 μ Wrms
	MMF Input, 850 nm No Filter	Typ. 8.1 μ Wrms Max. 10.5 μ Wrms	Typ. 11.4 μ Wrms Max. 14.9 μ Wrms
	When MP2110A-x30 is installed:		
	Conditions	When MP2110A-x54 is not installed	When MP2110A-x54 is installed*2
	SMF Input, 1310 nm OTU4 Filter	Typ. 4.8 μ Wrms Max. 6.1 μ Wrms	Typ. 6.8 μ Wrms Max. 8.6 μ Wrms
	SMF Input, 1310 nm No Filter	Typ. 7.6 μ Wrms Max. 10.6 μ Wrms	Typ. 10.8 μ Wrms Max. 15.0 μ Wrms
	When MP2110A-x40 is installed:		
	Conditions	When MP2110A-x54 is not installed	When MP2110A-x54 is installed*2
	SMF Input, 1310 nm OTU4 Filter	Typ. 5.8 μ Wrms Max. 7.3 μ Wrms	Typ. 8.2 μ Wrms Max. 10.4 μ Wrms
	SMF Input, 1310 nm No Filter	Typ. 7.8 μ Wrms Max. 10.6 μ Wrms	Typ. 11.0 μ Wrms Max. 15.0 μ Wrms
	When MP2110A-x42, x43, x45, x46, or x49 is installed:		
	Conditions	When MP2110A-x54 is not installed	When MP2110A-x54 is installed*2
	SMF Input, 1310 nm OTU4 Filter	Typ. 4.1 μ Wrms Max. 5.2 μ Wrms	Typ. 5.8 μ Wrms Max. 7.4 μ Wrms
	SMF Input, 1310 nm, No Filter	Typ. 5.5 μ Wrms Max. 7.5 μ Wrms	Typ. 7.8 μ Wrms Max. 10.6 μ Wrms
	MMF Input, 850 nm OTU4 Filter	Typ. 7.0 μ Wrms Max. 8.9 μ Wrms	Typ. 9.9 μ Wrms Max. 12.6 μ Wrms
	MMF Input, 850 nm No Filter	Typ. 8.6 μ Wrms Max. 11.1 μ Wrms	Typ. 12.1 μ Wrms Max. 15.7 μ Wrms

*2: When the MP2110A-x54 is installed, the specification values apply only to Channel B. To other channels, the specification values at “When MP2110A-x54 is not installed” always apply.

Table A.3.10-2 Optical Channel Performance (Cont'd)

Item	Specifications		
Optical Noise (cont'd)	When MP2110A-x40 and x61 are installed:		
	Conditions	When MP2110A-x54 is not installed	When MP2110A-x54 is installed*2
	SMF Input, 1310 nm OTU4 Filter	Typ. 4.1 μ Wrms Max. 5.2 μ Wrms	Typ. 5.8 μ Wrms Max. 7.4 μ Wrms
	SMF Input, 1310 nm No Filter	Typ. 5.5 μ Wrms Max. 7.5 μ Wrms	Typ. 7.8 μ Wrms Max. 10.6 μ Wrms
	SMF Input, 850 nm 100GbE/4 Filter	Typ. 12.2 μ Wrms Max. 14.0 μ Wrms	Typ. 17.3 μ Wrms Max. 19.8 μ Wrms
Mask Sensitivity	When MP2110A-x22, x23, x25, x26, x32, x33, x35, x36, or x39 is installed:		
	When MP2110A-x54 is not installed		When MP2110A-x54 is installed*2
	SMF: Typ. -15.0 dBm (1310 nm, OTU4 Filter) MMF: Typ. -12.0 dBm (850 nm, OTU4 Filter)		SMF: Typ. -13.5 dBm (1310 nm, OTU4 Filter) MMF: Typ. -10.5 dBm (850 nm, OTU4 Filter)
	When MP2110A-x30 is installed:		
	When MP2110A-x54 is not installed		When MP2110A-x54 is installed*2
	SMF: Typ. -13.5 dBm (1310 nm, OTU4 Filter)		SMF: Typ. -12.0 dBm (1310 nm, OTU4 Filter)
	When MP2110A-x40 is installed:		
	When MP2110A-x54 is not installed		When MP2110A-x54 is installed*2
	SMF: Typ. -12.0 dBm (1310 nm, OTU4 Filter)		SMF: Typ. -10.5 dBm (1310 nm, OTU4 Filter)
	When MP2110A-x42, x43, x45, x46, or x49 is installed:		
	When MP2110A-x54 is not installed		When MP2110A-x54 is installed*2
	SMF: Typ. -14.0 dBm (1310 nm, OTU4 Filter) MMF: Typ. -12.0 dBm (850 nm, OTU4 Filter)		SMF: Typ. -12.5 dBm (1310 nm, OTU4 Filter) MMF: Typ. -10.5 dBm (850 nm, OTU4 Filter)
	When MP2110A-x40 and x61 are installed:		
	When MP2110A-x54 is not installed		When MP2110A-x54 is installed*2
	SMF: Typ. -14.0 dBm (1310 nm, OTU4 Filter) SMF: Typ. -10.0 dBm (850 nm, 100GbE/4 Filter)		SMF: Typ. -12.5 dBm (1310 nm, OTU4 Filter) SMF: Typ. -8.5 dBm (850 nm, 100GbE/4 Filter)
Estimated optical power at which Mask Margin reaches 0% (calculated from the optical noise level)			

Table A.3.10-2 Optical Channel Performance (Cont'd)

Item	Specifications
<p>Maximum Input Power (Before Distortion)</p> <p>Absolute Maximum Power (Before Damage)</p> <p>Optical Return Loss</p>	<p>When MP2110A-x22, x23, x25, x26, x32, x33, x35, x36, x39, x42, x43, x45, x46, or x49 is installed: Typical -2 dBm (SMF Input), @ the signal of 1310 nm, ExR = 8 dB is observed. Typical +2 dBm (MMF Input), @ the signal of 850 nm, ExR = 3 dB is observed.</p> <p>When MP2110A-x30 or x40 is installed: Typical +2 dBm (SMF Input), @ the signal of 1310 nm, ExR = 4 dB is observed.</p> <p><Average> +5 dBm (SMF Input), +7 dBm (MMF Input)</p> <p><Peak> +8 dBm (SMF Input), +10 dBm (MMF Input)</p> <p>Typical -27 dB (SMF Input), @ 1310 nm SMF Fiber is connected Typical -20 dB (MMF Input), @ 850 nm MMF Fiber is connected</p>
<p>Optical Power Meter Range</p> <p>Accuracy</p>	<p>When MP2110A-x22, x23, x25, x26, x32, x33, x35, x36, x39, x42, x43, x45, x46, or x49 is installed: -18 to 0 dBm (SMF Input) -18 to +2 dBm (MMF Input)</p> <p>When MP2110A-x30 or x40 is installed: -18 to +2 dBm (SMF Input)</p> <p>Typical ±0.55 dB (0 to +2 dBm) Typical ±0.35 dB (-12 to 0 dBm) Typical ±0.6 dB (-18 to -12 dBm)</p>
<p>OE Monitor Out Conversion Gain</p> <p>Connector</p>	<p>Signal terminal to output after O/E conversion for CRU connection, added when MP2110A-x54 is installed.</p> <p>When MP2110A-x30 is installed: <SMF Input> Typical 48 V/W</p> <p>When MP2110A-x22, x23, x25, x26, x32, x33, x35, x36, or x39 is installed: <SMF Input> Typical 60 V/W <MMF Input> Typical 33 V/W</p> <p>When MP2110A-x40 is installed: <SMF Input> Typical 42 V/W</p> <p>When MP2110A-x42, x43, x45, x46, or x49 is installed: <SMF Input> Typical 53 V/W <MMF Input> Typical 29 V/W</p> <p>K Connector (f)</p>

A.3.11 CRU (MP2110A-x54)

Table A.3.11-1 CRU Input

Item	Specifications
Data Format	NRZ, PAM4 available (PRBS pattern)
Operation Baud Rate	25.5 to 28.2 Gbaud 25.5 to 28.9 Gbaud* ¹
Sensitivity	Typical 10 mVp-p* ^{2, *3, *4} Max. 20 mVp-p* ^{2, *3}
Maximum Amplitude	800 mVp-p
Maximum Amplitude (Before Damage)	1 Vp-p
Tolerance against consecutive 0s	500 bits or more at Zero Substitution Pattern PRBS 2 ¹⁵ -1
Connector	K Connector (f)
Termination	50 Ω, AC coupled* ⁵

*1: When MP2110A-x59 is installed

*2: With 25.78125 Gbit/s, PRBS 2³¹-1 NRZ, Loop Bandwidth = 10 MHz, Single-ended, Mark ratio 1/2, using MP2110A PPG

*3: When MP2110A-x59 is installed, with 28.9 Gbit/s, PRBS 2³¹-1 NRZ, Loop Bandwidth = 10 MHz, Single-ended, Mark ratio 1/2, using MP1900A PPG

*4: At 25±5°C

*5: DC component is terminated to the GND through a resistance of 50 Ω.

Table A.3.11-2 CRU Output

Item	Specifications
Output Mode	The signal output from CRU Output can be selected from Recovered Clock or input signal. The through output of the input signal can be output only when the input signal is Clock.
Recovered Mode	When CRU Output is set to Recovery Clock
Amplitude	Typical 480 mVp-p
Clock Frequency	12.75 to 14.1 GHz (Half Rate Clock) 12.75 to 14.45 GHz (Half Rate Clock) *1
Additive Jitter (RMS)	Typical 250 fs*2, *3, *4, *5 Max. 400 fs*3, *6
Loop Bandwidth	Selectable from the list as follows. 4MHz 10MHz Bitrate/1667 Attenuation: -20 dB/dec
Lock Detection	Detection function is available.
Through Mode	When CRU Output is set to Through
Amplitude	Typical 500 mVp-p
Operation Frequency	0.1 to 1.7625 GHz (1.7625 GHz is the 1/16 Clock of 28.2 GHz) 0.1 to 1.80625 GHz (1.80625 GHz is the 1/16 Clock of 28.9 GHz) *1
Additive Jitter (RMS)	Typical 200 fs*5, *6, *7, *8 Max. 400 fs*6, *7, *8
Connector	SMA, female
Termination	50 Ω, AC coupled
Waveform Format	Square wave

*1: When MP2110A-x59 is installed

*2: With 25.78125 Gbit/s, 26.5625 Gbit/s, and 28.05 Gbit/s, 1/4Clock Pattern, Loop Bandwidth = 10 MHz, Single-ended, using MP2110A PPG

*3: When MP2110A-x59 is installed, with 28.9 Gbit/s, 1/4Clock Pattern, Loop Bandwidth = 10 MHz, Single-ended, using MP1900A PPG

*4: Input amplitude 400±100 mVp-p

*5: At 25±5°C

*6: Input amplitude 400 mVp-p

*7: With 25.78125 Gbit/s, 26.5625 Gbit/s, and 28.05 Gbit/s, 1/16Clock Pattern, Single-ended, using MP2110A PPG

*8: When MP2110A-x59 is installed, with 28.9 Gbit/s, 1/16Clock Pattern, Single-ended, using MP1900A PPG

A.3.12 26G/53G CRU (MP2110A-x55)

Table A.3.12-1 Optical Data Input

Item	Specifications
Fiber	Singlemode fiber
Wavelength	1260 to 1620 nm
Data Format	NRZ, PAM4 available
Operation Baud Rate	51.0 to 58.0 Gbaud 25.5 to 28.9 Gbaud
Sensitivity (for 53G)	Typical Outer OMA 100 μ W* ¹ Max. Outer OMA 265 μ W* ²
Sensitivity (for 26G)	Typical Outer OMA 100 μ W* ³ Max. Outer OMA 265 μ W* ⁴
Stress Signal Sensitivity	Typical Outer OMA 630 μ W* ⁵
Absolute Maximum Power	+9.0 dBm (Average) +12.0 dBm (Peak)
Optical Return Loss	Typical -30 dB* ⁶
Tolerance against consecutive 0s	500 bits or more at Zero Substitution Pattern PRBS 2 ¹⁵ -1
Connector	FC/PC

*1: 53.125 Gbaud, PRBS13Q, PAM4, LBW = 4 MHz, TDECQ < 2.0 dB, at 25 \pm 5°C

*2: 51 Gaud, 53.125 Gbaud, 58 Gbaud, PRBS13Q, PAM4, TDECQ < 2.0 dB, LBW = 4MHz

*3: 26.5625 Gbaud, PRBS13Q, PAM4, LBW = 4 MHz, TDECQ < 2.0 dB, at 25 \pm 5°C

*4: 25.5 Gbaud, 26.5625 Gbaud, 28.9 Gbaud, PRBS13Q, PAM4, TDECQ < 2.0 dB, LBW = 4 MHz

*5: 53.125 Gbaud, SSPRQ, PAM4, LBW = 4 MHz, TDECQ \approx 3.4 dB, at 25 \pm 5°C

*6: At 1310 nm

Table A.3.12-2 Data Out SMF Optical

Item	Specifications
Insertion Loss	Typical 1.5 dB* Max. 2.3 dB*

*: At 1310 nm

Table A.3.12-3 Recovered Clock Output

Item	Specifications
Output Mode	The signal output from CRU Output can be selected from Recovered Clock or input signal. The through output of the input signal can be output only when the input signal is Clock.
Recovered Mode Amplitude Clock Frequency Additive Jitter (RMS) Loop Bandwidth Lock Detection	When Recovered Clock Out is set to Recovery Clock Typical 440 mVp-p Min. 340 mVp-p 6.375 to 7.25 GHz (1/8 Clock for 53 Gbaud Operation and 1/4 Clock for 26 Gbaud Operation) Typical 200 fs*1, *2, *3 Max. 400 fs*1, *2 Selectable from the list as follows. 2 MHz 4 MHz 10 MHz Bitrate/1667 Attenuation: -20 dB/dec Detection function is available.
Through Mode Amplitude Operation Frequency Additive Jitter (RMS)	When Recovered Clock Out is set to Through Typical 220 mVp-p Min. 200 mVp-p 0.1 to 1.81 GHz, 3.19 to 3.625 GHz (3.625 GHz is the 1/16 Clock of 58 GHz) Typical 200 fs*1, *3 Max. 400 fs*1
Connector Termination Waveform Format	SMA, Connector (f) 50 Ω, AC coupled Square wave

*1: 26.5625 Gbaud, 53.125 Gbaud, when inputting a clock pattern, Outer OMA = 0 dBm input

*2: LBW = 4 MHz

*3: At 25±5°C

A.4 General Performance

Table A.4-1 Functions

Item	Specifications
LED indicator BERT Option Scope Option	Standby, Power, Remote Fail, Status, Output, Error Fail, Status
Function	Panel lock, initialization, minimization of application window
File operation	Setup file save/load, result file save, screen copy, (jpg or png file format)
Recovery Disk	OS recovery can be executed using this disk. The application is installed by the user.
Remote interface	Ethernet, GPIB
Peripheral Devices connection	HDMI, Display Port, USB3.0 (4 ports on rear panel), USB2.0 (6 ports on front panel), Ethernet (2 ports, 10/100/1000 Base-T), Line-Out, Mic
OS	Windows Embedded Standard 7 or Windows 10 IoT Enterprise 2019 LTSC*
Internal storage devices	SSD, 60 GB or more

*: Operation not warranted when software installed after factory shipment

Table A.4-2 Environment Performance

Item	Specifications
EMC	EN61326-1, EN61000-3-2
LVD	EN61010-1
Power voltage*1	AC 100 to 120 V, 200 to 240 V, 50 to 60 Hz
Power consumption	300 VA or less*2
Operating temperature	+5 to +40°C
Storage temperature	-20 to +60°C

*1: Auto switch: 100/200 V

*2: The power consumption in the typical configuration (MP2110A-x14, x23) is 150 VA.

Table A.4-3 Size and Mass

Item	Specifications
Dimensions	142.5 mm(H) × 422 mm(W) × 389.4 mm(D), (excluding protrusions)
Mass	11 kg max.

Appendix B Initial Values

B.1 System Menu

Table B.1-1 Initial Values of System Menu

Item	Initial Value
Dock/Undock	Dock
Remote Control	
GPIB	
Address	1
Raw Socket	
Port Number	5001

B.2 PPG/ED

Table B.2-1 Initial Values of PPG/ED

Item	Initial Value
Data/XData	OFF
Bit Rate Standard	Variable
Bit Rate	25781250 kbit/s
Bit Rate Offset	0 ppm
PPG Amplitude	0.40 V _{p-p}
Ext ATT	0 dB
ED Input Condition	Single-Ended Data
Ext ATT	0 dB
Threshold	0 mV
PPG Test Pattern	PRBS 2 ⁹ -1
PPG Test Pattern Logic	POS
ED Test Pattern	PRBS 2 ⁹ -1
ED Test Pattern Logic	POS
ED Test Pattern Tracking	ON
ED Result	"All"
Result Time	Start Time
Reference CLK	Internal
Sync Out	PPG_1/8Clk
Clk Out	Ch1/2
Gating Cycle	Repeat
Gating Period	1 S
Current	ON

B.3 Scope

Table B.3-1 Initial Values of Result Window

Item	Initial Value
Ch A	ON* ¹ , * ³ OFF* ²
Ch B	ON
Ch C	ON* ³
Ch D	ON* ³
Control Ch	All
Graph display mode setting	Overlap* ¹ , * ³ Single* ²

*1: For MP2110A-x21, MP2110A-x22, MP2110A-x23, MP2110A-x32, MP2110A-x33, MP2110A-x42, and MP2110A-x43

*2: For MP2110A-x25, MP2110A-x26, MP2110A-x35, MP2110A-x36, MP2110A-x45, and MP2110A-x46,
Ch A is not displayed in Version 7 or later.

*3: For MP2110A-x30, MP2110A-x39, MP2110A-x40, and MP2110A-x49

For initial values of Scale/Offset, refer to Table B.3-7 “Amplitude Dialog Box”.

Table B.3-2 Setup Dialog Box

Item	Initial Value
General	
Sampling	
Sampling Type	NRZ
Sampling Mode	Eye
Test Pattern	Variable
Number of Samples	2048
Accumulation Type	Persistency
Limit Type	Time
Time	10.0 sec
Samples	10 million
Waveforms	100 wfms
Pattern	10 patterns
Averaging	Off
Utilities	
Color	
Waveform	Gray Scale
Mask	Purple
Display Information	
Preset Information	On
Label	(None)
Warning	
Overload	On
Questionable Eye	On
Save	
Screen Copy	
EYE/Pulse Shot	Capture
Inverse Background Color	Off
Waveforms Only	Off
Pattern Capture	
Samples / UI	32

Table B.3-3 Measure Dialog Box

Item	Initial Value
Amplitude/Time	
Display	On
Equalizer* ¹	
Display Equalized Waveform	On
Equalizer Type* ²	TDECQ
Equalizer No.1 Enable* ³	On
Equalizer No.2 Enable* ⁴	On
Equalizer No.3 Enable* ²	On
De-embedding File* ³	N/A
De-embedding Mode* ³	De-embedding
De-embedding File S-Parameter* ³	Off
De-embedding 4 Port Numbering* ³	1 ⇔ 2 3 ⇔ 4
De-embedding Antialiasing Filter* ³	Off
CTLE File* ⁴	N/A
Optimization* ²	Auto
Number of Precursors* ²	2
Tap Count* ²	5

*1: When MP2110A-x95 or MP2110A-x98 is installed.

*2: When MP2110A-x95 is installed.

*3: Electrical channels are available when MP2110A-x98 is installed. Optical channels are available when MP2110A-x95 or MP2110A-x98 is installed.

*4: When MP2110A-x98 is installed.

Table B.3-3 Measure Dialog Box (Cont'd)

Item	Initial Value
Equalizer*1 (Cont'd)	
	Tap*2
1	0.000000
2	0.000000
3	1.000000
4	0.000000
5	0.000000
6	0.000000
7	0.000000
8	0.000000
9	0.000000
10	0.000000
11	0.000000
12	0.000000
13	0.000000
14	0.000000
15	0.000000
16	0.000000
17	0.000000
18	0.000000
19	0.000000
20	0.000000
21	0.000000

Table B.3-3 Measure Dialog Box (Cont'd)

Item	Initial Value
Mask Test	
Mask Test	Off
Eye Mask Select	N/A
Test Method	One Shot
Margin Type	Hit Count
Hit Count	1 samples
Hit Ratio	5.0E-05
Mask Margin	0.0%
Align Method	Zero/One/Crossing
Align Marker	Display Off
X1	0.50 UI
ΔX	1.00 UI
Y1	*5
ΔY	*5
Mask Area Restriction	Off
Angle	0 degrees
Width	0.10 UI

*5: Initial value is not defined.

Table B.3-4 Setup (NRZ Amplitude/Time) Dialog Box

Item	Initial Value
Time	
Rise/Fall Time	20/80%
Rise/Fall Time Correction	Off
Correction Factor	0.0 ps
Eye Boundary	
Offset form Crossing	0.50 UI
Width	0.20 UI
SNR Definition	
Noise Measure Area	Zero Level + One Level

Table B.3-5 Setup (PAM4 Amplitude/Time) Dialog Box*

Item	Initial Value
Configuration	
Sample Timing	Track to Middle Eye Timing
Eye Center Type	Maximum Eye Width
Peak Power Hit Ratio	1.00%
EYE Height/Widths	
Eye Opening Definition	Zero Hits
Linearity Definition	IEEE Clause 94
TDECQ	
Target SER	IEEE
(mantissa)	4.80
(exponent)	E-04
Optimize Threshold	On
Optimize TDECQ Histogram	On
Noise Coefficient	1.00

*: When MP2110A-x95 is installed.

Table B.3-6 Jitter Measure Dialog Box*

Item	Initial Value
Algorithm	
PDJ Measurement	Off
Standard	STM-0(51.84M)
PDJ Filter	LP
Measurement Edge Type	ALL
Advanced	
TJ Measurement BER	1.00E-012
Fixed RJ	Off
RJ Value	1.00 ps rms
Correction Factor	Off
DJ (Scale)	1.00
RJ (Scale)	1.00
RJ (rms)	1.00 ps rms
Define Threshold	Auto
Manual Crossing	50%

*: When MP2110A-x96 is installed.

Table B.3-7 Amplitude Dialog Box

Item	Initial Value
Scale Offset	
Scale	100 mV/Div* ¹ (None)* ²
Offset	0 mV* ¹ 0 μW* ²
Attenuation	0 dB
Tracking* ³	Off
Channel Math* ⁴	Off
Define Function	CH A – CH B
Scale	* ⁵
Offset	0 mV
Digital Filter * ¹ ,* ⁶	No Filter
O/E* ²	
Input Connector (Wavelength)	MMF 850nm* ⁷ SMF 1550nm* ⁸
Conversion Gain	* ⁹
Responsivity	* ⁹
Input Power	-7.00 dBm
Filter Selection	No Filter
Extinction Ratio Correction	Off
Extinction Ratio Correction Factor	0.00%

*1: For electrical channels

*2: For optical channels

*3: Excluding MP2110A-x23, MP2110A-x25, MP2110A-x26, MP2110A-x33, MP2110A-x35, MP2110A-x36, MP2110A-x43, MP2110A-x45 and MP2110A-x46

*4: For MP2110A-x21

*5: Initial value is not defined.

*6: When MP2110A-x98 is installed.

*7: For MP2110A-x26, MP2110A-x36, MP2110A-x39, MP2110A-x46, and MP2110A-x49

*8: For MP2110A-x22, MP2110A-x23, MP2110A-x25, MP2110A-x30, MP2110A-x32, MP2110A-x33, MP2110A-x35, MP2110A-x40, MP2110A-x42, MP2110A-x43, 4and MP2110A-x45

*9: This value has been set at the factory to achieve Input Connector (Wavelength) default wavelength.

Table B.3-8 Time Dialog Box

Item	Initial Value
Rate	
Data Clock Rate	
Tracking	Off
Tracking Target	26G
Recalculate Option	Clock Rate
Clock Rate	6 445 313 kHz
Divide Ratio	4
Symbol Rate	25 781 250 kbaud
Divide Ratio Detect	On
Precision Trigger*1	Off
Scale/Offset	
Unit	UI
UI On Screen	2 UI
Offset*2	0.00 UI
Pattern Length	
Tracking	Off
Master	PPG1
Length	511 symbols
Software Delay	
Channel A	0.0 ps
Channel B	0.0 ps
Channel C	0.0 ps
Channel D	0.0 ps
CRU or CRU(26G)*3	
Operation Mode	Off
Clock Recovery	
Operation Rate (Rate)	Variable 25 781 250 kbaud
CRU Loop BW	10 MHz
Auto Relock	On
CRU or CRU(53G)*4	
Operation Mode	Off
Clock Recovery	
Operation Rate (Rate)	Variable (51.0-58.0Gbaud) 53 125 000 kbaud
CRU Loop BW	4 MHz
Auto Relock	Off

*1: When MP2110A-x24 is installed.

*2: When Sampling Mode is set to **Pulse**.

*3: When MP2110A-x54 is installed.

*4: When MP2110A-x55 is installed.

Table B.3-9 Histogram Panel

Item	Initial Value
Histogram	Off
Axis	Amplitude
X1	0.50 UI
X2	1.50 UI
Y1	100 mV* ¹ 100 μ W* ²
Y2	-100 mV* ¹ -100 μ W* ²

*1: For MP2110A-x21, MP2110A-x23, MP2110A-x33, and MP2110A-x43

*2: For MP2110A-x22, MP2110A-x25, MP2110A-x26, MP2110A-x30, MP2110A-x32, MP2110A-x35, MP2110A-x36, MP2110A-x39, MP2110A-x40, MP2110A-x42, MP2110A-x45, MP2110A-x46, and MP2110A-x49

Table B.3-10 Marker Panel

Item	Initial Value
Marker Disp	Off
X1	Off
X2	Off
Y1	Off
Y2	Off

Appendix C File Specifications

Appendix C describes the specifications for mask files.

C.1	Mask file Specifications	C-2
C.2	S Parameter File	C-5

C.1 Mask file Specifications

The mask file specifications reading with Sampling oscilloscope is as follows.

Table C.1-1 Mask File Specifications

Item	Specification
Save folder	C:\Users\Public\Documents\Anritsu\MX21000A\Userdata\Mask
File extension	txt

The mask file is the text format file.

Describe the coordinates of the mask vertices, in which the mask margins are 100% (max.), 0%, and -100% (min), in the file.

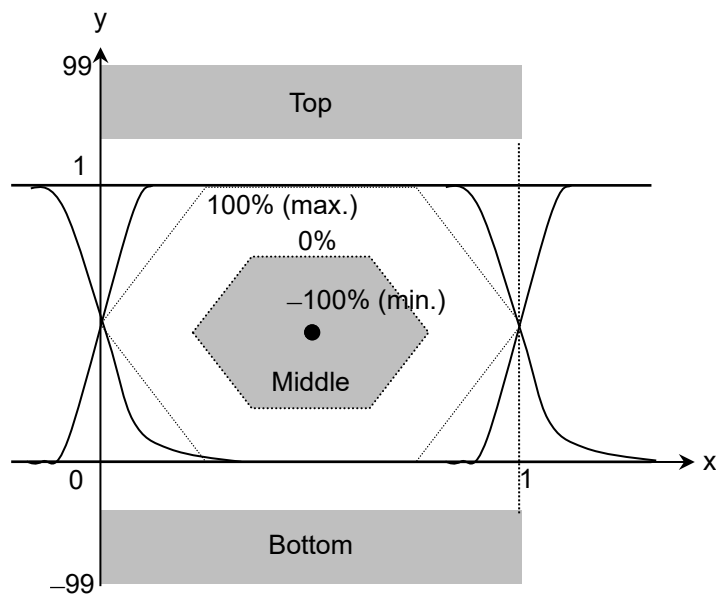

Figure C.1-1 Coordinate System of Mask

The following items are described in the mask file.

Table C.1-2 Details of Mask File

Item	Parameter to be set	Description
Version	Masks Version#1	Make sure that the version is written.
Mask name	Mask name	Mask name displayed on the measurement screen.
Mask type	Relative Mask Fixed Mask	Relative: Sets coordinate of amplitude direction by rate. The Mask coordinate varies with the amplitude of input signal. Fixed: Sets coordinate of amplitude direction at the fixed value. The Mask coordinate does not vary with the amplitude of input signal.
Coordinates in the top	TOP X Y X_min Y_min X_max Y_max	Specifies each X and Y coordinate in the area of Top/Middle/Bottom. As for X_min and Y_min, set the coordinate at -100% of Mask Margin. As for X_max, and Y_max, set the coordinate at +100% of Mask Margin.
Coordinates in the middle	MIDDLE X Y X_min Y_min X_max Y_max	
Coordinates in the bottom	BOTTOM X Y Y_min X_max Y_max	

```

>>>>>>>>> START >>>>>>>>>
Masks Version#1
<1GFC ; 1G Optical Fibre Channel Mask (1.0625 Gbps)> Relative Mask;

Top   X      Y      X_min Y_min X_max Y_max
      0      99      0      99      0      99
      0      1.3    0      1.6    0      1
      1      1.3    1      1.6    1      1
      1      99      1      99      1      999
      -1     -1     -1     -1     -1     -1
      -1     -1     -1     -1     -1     -1
      -1     -1     -1     -1     -1     -1
      -1     -1     -1     -1     -1     -1
      -1     -1     -1     -1     -1     -1
      -1     -1     -1     -1     -1     -1
Middle X      Y      X_min Y_min X_max Y_max
      0.215  0.5    0.5    0.5    0      0.5
      0.4    0.8    0.5    0.5    0.4    1
      0.6    0.8    0.5    0.5    0.6    1
      0.785  0.5    0.5    0.5    1      0.5
      0.6    0.2    0.5    0.5    0.6    0
      0.4    0.2    0.5    0.5    0.4    0
      -1     -1     -1     -1     -1     -1
      -1     -1     -1     -1     -1     -1
      -1     -1     -1     -1     -1     -1
      -1     -1     -1     -1     -1     -1
Bottom X      Y      X_min Y_min X_max Y_max
      0      -99     0      -99     0      -99
      0      -0.2    0      -0.4    0      0
      1      -0.2    1      -0.4    1      0
      1      -99     1      -99     1      -99
      -1     -1     -1     -1     -1     -1
      -1     -1     -1     -1     -1     -1
      -1     -1     -1     -1     -1     -1
      -1     -1     -1     -1     -1     -1
      -1     -1     -1     -1     -1     -1
      -1     -1     -1     -1     -1     -1
>>>>>>>>> END >>>>>>>>>

```

Figure C.1-2 Example of Mask File

C.2 S Parameter File

When the MP2110A-x98 is added, the Equalizer of the Scope loads a frequency characteristics file and adds and cancels the contained frequency characteristics. The frequency characteristics are loaded from a text file that describes the frequencies and S parameters.

The file is stored in the folder below:

C:\Users\Public\Documents\Anritsu\MX210000A\Userdata\DeEmbedding

s2p format

Text files with description of 2D S parameter values

Frequency and amplitude/phase data of pass characteristics (S_{21} , S_{12}) and reflection characteristics (S_{11} , S_{22}) are described.

The Equalizer processing uses only the pass characteristics data in the s2p format file.

The MX210000A does not use the reflection characteristics data even if it exists in the file to load.

```
!MX210002A 2011/6/20
!
!freq-unit  param-type  data-format  keyword  impedance-ohms
# GHz      S          MA          R          50
!-----
!Freq      MagS11     AngS11     MagS21     AngS21     MagS12     AngS12     MagS22     AngS22
0.000000  0.0        0.0        1.002635   -7.374129  0.0        0.0        0.0        0.0
0.025000  0.0        0.0        1.002635   -7.374129  0.0        0.0        0.0        0.0
0.050000  0.0        0.0        1.002635   -7.374129  0.0        0.0        0.0        0.0
0.075000  0.0        0.0        1.002635   -7.374129  0.0        0.0        0.0        0.0
0.100000  0.0        0.0        1.002635   -7.374129  0.0        0.0        0.0        0.0
0.125000  0.0        0.0        1.002635   -7.374129  0.0        0.0        0.0        0.0
0.150000  0.0        0.0        1.002509   -7.969909  0.0        0.0        0.0        0.0
0.175000  0.0        0.0        1.002497   -8.516415  0.0        0.0        0.0        0.0
0.200000  0.0        0.0        1.002532   -7.058710  0.0        0.0        0.0        0.0
0.225000  0.0        0.0        1.002561   -6.454731  0.0        0.0        0.0        0.0
0.250000  0.0        0.0        1.002616   -5.939568  0.0        0.0        0.0        0.0
0.275000  0.0        0.0        1.002790   -6.543123  0.0        0.0        0.0        0.0
0.300000  0.0        0.0        1.002752   -6.029175  0.0        0.0        0.0        0.0
0.325000  0.0        0.0        1.002562   -5.344590  0.0        0.0        0.0        0.0
0.350000  0.0        0.0        1.002473   -5.669611  0.0        0.0        0.0        0.0
0.375000  0.0        0.0        1.002506   -5.325497  0.0        0.0        0.0        0.0
0.400000  0.0        0.0        1.002543   -3.542136  0.0        0.0        0.0        0.0
0.425000  0.0        0.0        1.002522   -3.351720  0.0        0.0        0.0        0.0
0.450000  0.0        0.0        1.002260   -2.983581  0.0        0.0        0.0        0.0
0.475000  0.0        0.0        1.002289   -3.177759  0.0        0.0        0.0        0.0
0.500000  0.0        0.0        1.002500   -3.566260  0.0        0.0        0.0        0.0
0.525000  0.0        0.0        1.002587   -3.764469  0.0        0.0        0.0        0.0
0.550000  0.0        0.0        1.002462   -2.703423  0.0        0.0        0.0        0.0
0.575000  0.0        0.0        1.002529   -1.676393  0.0        0.0        0.0        0.0
0.600000  0.0        0.0        1.002482   -1.864907  0.0        0.0        0.0        0.0
0.625000  0.0        0.0        1.002535   -2.331279  0.0        0.0        0.0        0.0
0.650000  0.0        0.0        1.002554   -2.544649  0.0        0.0        0.0        0.0
0.675000  0.0        0.0        1.002582   -2.113384  0.0        0.0        0.0        0.0
0.700000  0.0        0.0        1.002786   -1.604808  0.0        0.0        0.0        0.0
0.725000  0.0        0.0        1.002910   -1.886435  0.0        0.0        0.0        0.0
0.750000  0.0        0.0        1.002988   -0.975934  0.0        0.0        0.0        0.0
0.775000  0.0        0.0        1.003041   -1.125352  0.0        0.0        0.0        0.0
0.800000  0.0        0.0        1.003146   -0.299080  0.0        0.0        0.0        0.0
```

Figure C.2-1 File Example for s2p Format

s4p format

The Equalizer processing uses the values of the Mixed Mode S parameters calculated from the pass characteristics corresponding to the De-embedding Flip S-Parameter and De-embedding 4 Port Numbering settings.

```

! 7/13/2011 3:38:22 PM
! E:\YH17_H18 27INCHES 334PTS WITH BLUE CABLES_D.S4P
! CHANNEL_1
! TR.MEASUREMENT
! CORRECTED.DATA
# GHZ S RI R 50.0
! FREQ.GHZ
!
! S11RE S11IM S12RE S12IM S13RE S13IM S14RE S14IM
! S21RE S21IM S22RE S22IM S23RE S23IM S24RE S24IM
! S31RE S31IM S32RE S32IM S33RE S33IM S34RE S34IM
! S41RE S41IM S42RE S42IM S43RE S43IM S44RE S44IM
!; PortSelection: Port_1234
0.000070000 0.0284027 0.0009668 -0.0004664 0.0006219 0.6584494 -0.0059120 -0.0008744 -0.0015127
-0.0006316 0.0005547 0.0240792 -0.0003294 -0.0006752 -0.0015253 0.6628518 -0.0041101
0.6619428 -0.0041337 -0.0003821 -0.0004105 0.0271173 0.0017439 0.0002420 -0.0008705
-0.0005134 -0.0004481 0.6647863 -0.0068479 0.0002165 -0.0008964 0.0256025 0.0025547
0.125383108 0.0477104 -0.0024019 0.0420608 0.0259672 0.6144243 -0.4755415 0.0030628 0.0078372
0.0419931 0.0259166 0.0533130 -0.0087509 0.0030981 0.0084906 0.6184164 -0.4788730
0.6148008 -0.4766030 0.0030466 0.0085106 0.0478268 0.0277937 0.0225848 0.0419859
0.0031333 0.0079110 0.6191277 -0.4806471 0.0226212 0.0419986 0.0352512 0.0306154
0.250696216 0.0380989 -0.0397731 0.0536892 -0.0084251 0.2395749 -0.6915352 0.0145061 0.0064102
0.0537139 -0.0084368 0.0392565 -0.0463589 0.0150198 0.0065719 0.2425124 -0.6948401
0.2405008 -0.6935092 0.0149321 0.0063964 0.0439622 0.0356846 0.0386077 0.0349467
0.0146098 0.0064701 0.2417046 -0.6973683 0.0385598 0.0349180 0.0384348 0.0395513
0.376009323 -0.0123162 0.0053029 0.0070809 -0.0107661 -0.1586659 -0.6829085 0.0213362 -0.0074848
0.0071771 -0.0108284 -0.0212343 0.0074978 0.0213267 -0.0078433 -0.1570560 -0.6854615
-0.1599129 -0.6834644 0.0213164 -0.0079516 -0.0102746 0.0103038 0.0086972 0.0084908
0.0214681 -0.0075305 -0.1586202 -0.6876989 0.0086368 0.0084608 -0.0212463 0.0086875
0.501322431 0.0303552 0.0294044 0.0181837 0.0341020 -0.4750811 -0.4722240 0.0180806 -0.0181143
0.0182229 0.0341093 0.0219857 0.0270775 0.0176553 -0.0179271 -0.4734309 -0.4775656
-0.4758781 -0.4729796 0.0175831 -0.0180549 -0.0447503 0.0175638 -0.0359664 -0.0008058
0.0179684 -0.0181908 -0.4753254 -0.4775926 -0.0360006 -0.0009413 -0.0434360 0.0242188
0.626635539 0.0532951 0.0032990 0.0588308 0.0154733 -0.6255297 -0.1488052 0.0084022 -0.0282436
0.0587991 0.0156524 0.0550492 0.0005107 0.0093887 -0.0283406 -0.6276904 -0.1532331

```

Figure C.2-2 File Example for s4p Format

D.1 Pulse Pattern Generator

Measurement Uncertainty

The measurement uncertainty is up to double the amplitude measurement accuracy of the measuring instrument. When a value of which the measurement uncertainty is added or subtracted to/from the measurement value is in the range of the specifications, the value passes.

The measurement uncertainty of the frequency accuracy when using MF2412C Microwave Frequency Counter as the frequency counter is shown below.

Without MF2412C-003: 0.1 ppm
With MF2412C-003: 0.01 ppm

Refer to Amplitude accuracy in Table A.3.9-2 “Electrical Channel Performance” for the amplitude measurement uncertainty when using MP2110A as the sampling oscilloscope. Examples of calculating the amplitude measurement uncertainty are listed below.

Table D.1-1 Amplitude Measurement Uncertainty

Measured Value (V)	Measurement Accuracy (mV)*	Measurement Uncertainty (mV)
0.96	19.6	39.2
0.80	17.2	34.4
0.64	14.8	29.6
0.12	7.0	14.0
0.10	6.7	13.4
0.08	5.5	11.0

*: The measurement uncertainty when Scale and Offset are set as follows:

Scale: 100 mV/div

Offset: 0 mV

**Table D.1-2 Pulse Pattern Generator Performance Test Record Form
(Without MP2110A-x93)**

Frequency Accuracy					
Connector	Set Bit Rate (kbit/s)	Minimum Value (kHz)	Measured Value (kHz)	Maximum Value (kHz)	Pass/Fail
Sync Out	28200000	3524964.8		3525035.2	Pass/Fail
	24300000	3037469.7		3037530.3	Pass/Fail
Measurement Channel PPG 1 2 3 4					
Waveform (Amplitude)					
Connector	Set Amplitude	Minimum Value	Measured Value	Maximum Value	Pass/Fail
Data Out	0.1 V _{p-p}	0.06 V _{p-p}	V _{p-p}	0.14 V _{p-p}	Pass/Fail
	0.8 V _{p-p}	0.62 V _{p-p}	V _{p-p}	0.98 V _{p-p}	Pass/Fail
$\overline{\text{Data Out}}$	0.1 V _{p-p}	0.06 V _{p-p}	V _{p-p}	0.14 V _{p-p}	Pass/Fail
	0.8 V _{p-p}	0.62 V _{p-p}	V _{p-p}	0.98 V _{p-p}	Pass/Fail
Waveform					
Connector	Item	Minimum Value	Measured Value	Maximum Value	Pass/Fail
Data Out	Crossing	40%	%	60%	Pass/Fail
	Rise Time		ps	17 ps	Pass/Fail
	Fall Time		ps	17 ps	Pass/Fail
	Jitter (rms)		ps	0.9 ps	Pass/Fail
$\overline{\text{Data Out}}$	Crossing	40%	%	60%	Pass/Fail
	Rise Time		ps	17 ps	Pass/Fail
	Fall Time		ps	17 ps	Pass/Fail
	Jitter (rms)		ps	0.9 ps	Pass/Fail
Skew					
Connector	Set Amplitude	Minimum Value	Measured Value	Maximum Value	Pass/Fail
Data Out, $\overline{\text{Data Out}}$	0.3 V _{p-p}		ps	±8 ps	Pass/Fail

Appendix D Performance Test Record Form

Table D.1-3 Pulse Pattern Generator Performance Test Record Form (With MP2110A-x93)

Frequency Accuracy					
Connector	Set Bit Rate (kbit/s)	Minimum Value (kHz)	Measured Value (kHz)	Maximum Value (kHz)	Pass/Fail
Sync Out	28200000	3524964.8		3525035.2	Pass/Fail
	9500000	1187488.2		1187511.8	Pass/Fail
Measurement Channel PPG 1 2 3 4					
Waveform (Amplitude)					
Connector	Set Amplitude	Minimum Value	Measured Value	Maximum Value	Pass/Fail
Data Out	0.1 V _{p-p}	0.06 V _{p-p}	V _{p-p}	0.14 V _{p-p}	Pass/Fail
	0.8 V _{p-p}	0.62 V _{p-p}	V _{p-p}	0.98 V _{p-p}	Pass/Fail
$\overline{\text{Data Out}}$	0.1 V _{p-p}	0.06 V _{p-p}	V _{p-p}	0.14 V _{p-p}	Pass/Fail
	0.8 V _{p-p}	0.62 V _{p-p}	V _{p-p}	0.98 V _{p-p}	Pass/Fail
Waveform					
Connector	Item	Minimum Value	Measured Value	Maximum Value	Pass/Fail
Data Out	Crossing	40%	%	60%	Pass/Fail
	Rise Time		ps	17 ps	Pass/Fail
	Fall Time		ps	17 ps	Pass/Fail
	Jitter (rms)		ps	0.9 ps	Pass/Fail
$\overline{\text{Data Out}}$	Crossing	40%	%	60%	Pass/Fail
	Rise Time		ps	17 ps	Pass/Fail
	Fall Time		ps	17 ps	Pass/Fail
	Jitter (rms)		ps	0.9 ps	Pass/Fail
Skew					
Connector	Set Amplitude	Minimum Value	Measured Value	Maximum Value	Pass/Fail
Data Out, $\overline{\text{Data Out}}$	0.3 V _{p-p}		ps	±8 ps	Pass/Fail

D.2 Error Detector

Table D.2-1 Error Detector Performance Test Record Form (Without MP2110A-x93)

Measurement Channel		ED	1	2	3	4
Operating Frequency						
Connector	Set Bit Rate	Minimum Value	Measured ER Value	Maximum Value	Pass/Fail	
Data Out	28200000 kbit/s			1E-12	Pass/Fail	
	24300000 kbit/s			1E-12	Pass/Fail	
Data Out	28200000 kbit/s			1E-12	Pass/Fail	
	24300000 kbit/s			1E-12	Pass/Fail	
Rx Sensitivity						
Connector	Set Bit Rate	Minimum Value	Measured ER Value	Maximum Value	Pass/Fail	
Data Out	25781250 kbit/s			1E-12	Pass/Fail	
Data Out	25781250 kbit/s			1E-12	Pass/Fail	
Input Level • Pattern						
Connector	Pattern	Minimum Value	Measured ER Value	Maximum Value	Pass/Fail	
Data Out	PRBS2 ⁷⁻¹			1E-12	Pass/Fail	
	PRBS2 ⁹⁻¹			1E-12	Pass/Fail	
	PRBS2 ¹⁵⁻¹			1E-12	Pass/Fail	
	PRBS2 ²³⁻¹			1E-12	Pass/Fail	
	PRBS2 ³¹⁻¹			1E-12	Pass/Fail	
Data Out	PRBS2 ⁷⁻¹			1E-12	Pass/Fail	
	PRBS2 ⁹⁻¹			1E-12	Pass/Fail	
	PRBS2 ¹⁵⁻¹			1E-12	Pass/Fail	
	PRBS2 ²³⁻¹			1E-12	Pass/Fail	
	PRBS2 ³¹⁻¹			1E-12	Pass/Fail	

Table D.2-1 Error Detector Performance Test Record Form (Without MP2110A-x93) (Cont'd)

Error Detection					
Connector	Set Bit Rate	Minimum Value	Measured EC Value	Maximum Value	Pass/Fail
Data Out	25781250 kbit/s			20	Pass/Fail
$\overline{\text{Data Out}}$	25781250 kbit/s			20	Pass/Fail

Table D.2-2 Error Detector Performance Test Record Form (With MP2110A-x93)

Measurement Channel						ED	1	2	3	4
Operating Frequency										
Connector	Set Bit Rate	Minimum Value	ER Measured Value	Maximum Value	Pass/Fail					
Data Out	28200000 kbit/s			1E-12	Pass/Fail					
	9500000 kbit/s			1E-12	Pass/Fail					
Data Out	28200000 kbit/s			1E-12	Pass/Fail					
	9500000 kbit/s			1E-12	Pass/Fail					
Rx Sensitivity										
Connector	Set Bit Rate	Minimum Value	ER Measured Value	Maximum Value	Pass/Fail					
Data Out	25781250 kbit/s			1E-12	Pass/Fail					
Data Out	25781250 kbit/s			1E-12	Pass/Fail					
Input Level • Pattern										
Connector	Pattern	Minimum Value	ER Measured Value	Maximum Value	Pass/Fail					
Data Out	PRBS2 ⁷⁻¹			1E-12	Pass/Fail					
	PRBS2 ⁹⁻¹			1E-12	Pass/Fail					
	PRBS2 ¹⁵⁻¹			1E-12	Pass/Fail					
	PRBS2 ²³⁻¹			1E-12	Pass/Fail					
	PRBS2 ³¹⁻¹			1E-12	Pass/Fail					
Data Out	PRBS2 ⁷⁻¹			1E-12	Pass/Fail					
	PRBS2 ⁹⁻¹			1E-12	Pass/Fail					
	PRBS2 ¹⁵⁻¹			1E-12	Pass/Fail					
	PRBS2 ²³⁻¹			1E-12	Pass/Fail					
	PRBS2 ³¹⁻¹			1E-12	Pass/Fail					

Table D.2-2 Error Detector Performance Test Record Form (With MP2110A-x93) (Cont'd)

Error Detection					
Connector	Set Bit Rate	Minimum Value	EC Measured Value	Maximum Value	Pass/Fail
Data Out	25781250 kbit/s			20	Pass/Fail
$\overline{\text{Data Out}}$	25781250 kbit/s			20	Pass/Fail

D.3 Sampling Oscilloscope

For details of the performance test, refer to 7.3 “Performance Test for Sampling Oscilloscope”.

Amplitude Accuracy

Table D.3-1 Level Accuracy

Connector	Setting Voltage	Minimum Value	Measured Value	Maximum Value	Pass/Fail
Ch A	+200 mV	+188 mV	mV	+212 mV	Pass/Fail
	-200 mV	-215 mV	mV	-185 mV	Pass/Fail
Ch B	+200 mV	+188 mV	mV	+212 mV	Pass/Fail
	-200 mV	-215 mV	mV	-185 mV	Pass/Fail

Optical Power Meter: ± 0.35 dB or less (-12 to 0 dBm, typical)

± 0.35 dB is a typical value. In the actual measurement, it is necessary to consider the uncertainty due to the optical fiber connector.

Table D.3-2 Accuracy of Optical Power Meter (Ch A)

Connector	Wavelength	Reading of Optical Power Meter	Measured Average Power (dBm) Value	Minimum Value	Level Difference	Maximum Value
MMF	850 nm	dBm	dBm		dB	
SMF	1310 nm	dBm	dBm		dB	
SMF	1550 nm	dBm	dBm		dB	

Table D.3-3 Accuracy of Optical Power Meter (Ch B)

Connector	Wavelength	Reading of Optical Power Meter	Average Power (dBm) Measurement Value	Minimum Value	Level Difference	Maximum Value
MMF	850 nm	dBm	dBm		dB	
SMF	1310 nm	dBm	dBm		dB	
SMF	1550 nm	dBm	dBm		dB	

Table D.3-4 Accuracy of Optical Power Meter (Ch C)

Connector	Wavelength	Reading of Optical Power Meter	Average Power (dBm) Measurement Value	Minimum Value	Level Difference	Maximum Value
MMF	850 nm	dBm	dBm		dB	
SMF	1310 nm	dBm	dBm		dB	
SMF	1550 nm	dBm	dBm		dB	

Table D.3-5 Accuracy of Optical Power Meter (Ch D)

Connector	Wavelength	Reading of Optical Power Meter	Average Power (dBm) Measurement Value	Minimum Value	Level Difference	Maximum Value
MMF	850 nm	dBm	dBm		dB	
SMF	1310 nm	dBm	dBm		dB	
SMF	1550 nm	dBm	dBm		dB	

CRU (MP2110A-x54)

Table D.3-6 CRU Output

Sensitivity			
Pass/Fail			
Additive jitter			
Operation Rate	Jitter RMS*1	Jitter RMS*2	Calculated Value*3
25.78125 Gbaud			
26.5625 Gbaud			
28.05 Gbaud			

*1: Result obtained by measuring PPG1 Data waveform

*2: Result obtained by measuring CRU Out waveform

*3: Calculate the value using the following formula.

$$J_{Add} = \sqrt{(J_{CRU})^2 - (J_{PPG})^2}$$

26G/53G CRU (MP2110A-x55)

Table D.3-7 CRU Output

Sensitivity	Pass/Fail
-------------	-----------

Appendix E Bibliography

- (1) IEC60825-1 *Safety of laser products. Part 1: Equipment classification, requirements and user's guide*
- (2) IEC61010-1 *Safety requirements for electrical equipment for measurement, control, and laboratory use - Part 1: General requirements*
- (3) IEC61280-2-1 *Fibre optic communication subsystem basic test procedures - Part 2-1: Test procedures for digital systems - Receiver sensitivity and overload measurement*
- (4) IEC61280-2-2 *Fibre optic communication subsystem test procedures - Part 2-2: Digital systems Optical eye pattern, waveform and extinction ratio measurement*
- (5) IEC62150-2 *Fibre optic active components and devices - Test and measurement procedures - Part 2: ATM-PON transceivers*
- (6) IEEE Std 802.3-2015 *IEEE Standard for Ethernet*
- (7) ISO/IEC 14165-115 *Information technology - Fibre channel - Part 115: Physical interfaces (FC-PI)*
- (8) ITU-T G.651.1 *Characteristics of a 50/125 μm multimode graded index optical fibre cable for the optical access network*
- (9) ITU-T G.652 *Characteristics of a single-mode optical fibre and cable*
- (10) ITU-T G.707 *Network node interface for the synchronous digital hierarchy (SDH)*
- (11) ITU-T G.709 *Interfaces for Optical Transport Network (OTN)*
- (12) ITU-T G.825 *The control of jitter and wander within digital networks which are based on the synchronous digital hierarchy (SDH)*
- (13) ITU-T G.957 *Optical interfaces for equipments and systems relating to the synchronous digital hierarchy*
- (14) ITU-T O.150 *General requirements for instrumentation for performance measurements on digital transmission equipment*
- (15) ITU-T O.151 *Error performance measuring equipment operating at the primary rate and above*
- (16) ITU-T O.172 *Jitter and wander measuring equipment for digital systems which are based on the synchronous digital hierarchy (SDH)*
- (17) ITU-T O.173 *Jitter measuring equipment for digital systems which are based on the Optical Transport Network (OTN)*
- (18) ANSI INCITS Project 2221-D / Rev 3.10 *Fibre Channel - Physical Interface-6 (FC-PI-6)*
- (19) *InfiniBand Architecture Specification Volume 2 Release 1.3.1*
- (20) CFP MSA *CFP Hardware Specification Revision 1.0*

- (21) CFP MSA *CFP4 Hardware Specification Revision 1.1*
- (22) SFF Committee SFF-8438i *QSFP (Quad Formfactor Pluggable) Transceiver Rev 1.0*
- (23) SFF Committee SFF-8635 *QSFP+ 10 Gb/s 4X Pluggable Transceiver Solution (QSFP10) Rev 0.6*
- (24) SFF Committee SFF-8665 *QSFP+ 28 Gb/s 4X Pluggable Transceiver Solution (QSFP28) Rev 1.9*
- (25) SFF Committee SFF-8679 *QSFP+ 4X Base Electrical Specification Rev 1.7*
- (26) Common Public Radio Interface *CPRI Specification V7.0*
- (27) Open Base Station Architecture Initiative *Reference Point 3 Specification Version 4.2*
- (28) Anritsu Corporation *Selecting Tools at Measurement of High-Speed Digital Signals*
<https://www.anritsu.com/en-US/test-measurement/support/downloads/technical-notes/dwl009698>
- (29) Anritsu Corporation *Measurement Environment Solutions for Eliminating ESD/EOS*
<https://www.anritsu.com/en-US/test-measurement/support/downloads/application-notes/dwl18357>
- (30) Anritsu Corporation *Jitter Analysis - Basic Classification of Jitter Components using Sampling Scope*
<https://www.anritsu.com/en-US/test-measurement/support/downloads/application-notes/dwl009658>
- (31) Anritsu Corporation *Measurement Intrinsic Jitter Correction for Jitter Measurements*
<https://www.anritsu.com/en-US/test-measurement/support/downloads/technical-notes/dwl009659>
- (32) Anritsu Corporation *Procedure for Calculating Extinction Ratio Correction Factor*
<https://www.anritsu.com/en-US/test-measurement/support/downloads/manuals/dwl010776>
- (33) Anritsu Corporation *Signal Integrity Analysis of 28 Gbit/s High-Speed Digital Signal*
<https://www.anritsu.com/en-US/test-measurement/support/downloads/application-notes/dwl008945>
- (34) Anritsu Corporation *PAM4 Signal Generation and BER Measurement Solution*
<https://www.anritsu.com/en-US/test-measurement/support/downloads/product-introductions/dwl17851>

References are to page numbers.

Symbol and Numbers

1

1/16 Clock Pattern.....	5-11
1/2 Clock Pattern.....	5-11
1/2Clock.....	5-16
1/4Clock.....	5-16

A

Abbreviation.....	1-48
Accumulation Type.....	6-77
Acquire Clock Rate.....	6-73
Add.....	6-126
Adjusting Horizontal-axis of Waveform Display Area.....	6-87
Adjusting mask position.....	6-109
Adjusting Screen Scale.....	6-82
Adjusting the number of bits to display.....	6-87
Adjusting time at left edge of waveform display area.....	6-87
Adjusting Vertical-axis Screen.....	6-85
Advanced tab.....	6-42
Algorithm.....	6-40
Alignment Marker.....	6-109
All BER Results.....	4-22
All Edges.....	6-23
All Measurements.....	4-20
All Off.....	6-122
All Outputs.....	4-19
All Samples.....	6-23
Amplitude and time measurements.....	6-88
Amplitude O/E.....	6-49
Amplitude/Time.....	6-32
Angle.....	6-110
Application Window.....	2-22
Arrow Key Entry Panel.....	4-5
Attenuation.....	6-86
Attenuator Factor.....	5-19
Auto Scale.....	6-82, 6-83
averaging.....	6-79
Averaging.....	6-80
Averaging process.....	6-79

B

Basic Procedure of Generating Pulse Signal.....	5-2
Bathtub.....	1-23, 6-18, 6-20
Before Use.....	4-13
BERT Panel Names.....	2-7
BERTWave Types.....	1-2
Bit Error Rate.....	1-21
Bit Rate.....	1-22, 5-5
Bit Rate Standard Value.....	5-8
Bottom Mask Failed Samples.....	6-108
BUJ.....	1-35

C

CAL.....	6-13
Calibrating Sampling Oscilloscope.....	6-62
Calibration.....	8-31
Capture.....	6-129
Cautions on Handling Optical Fiber Cables.....	2-18
CC.....	5-26
CE Conformity Marking.....	xvi
Center.....	6-25, 6-110, 6-120, 6-122
Center Mask Failed Samples.....	6-108
Ch Tracking.....	4-21
Ch1/2.....	5-16
Ch3/4.....	5-16
Change Network Connections.....	4-16
Changing the window display method.....	4-14
Channel Math.....	6-124
Cleaning the Ferrule End Surface.....	8-5
Cleaning the Optical Adapter.....	8-6
Cleaning the Optical Fiber Cable Ferrule End Surface.....	8-7
Clear.....	6-125
Clk Out.....	5-6, 5-16
Coherent Eye.....	6-124
Composite Histogram.....	6-22
Connect the coaxial cable.....	2-20
Connecting Peripheral Devices.....	2-15
Connecting Power Cord.....	2-14
Connecting Remote Control Devices.....	2-16
Continues Time Linear Equalizer.....	1-23

Index

Continuous6-106
Control Ch 6-5
Correction Factor.....6-43
Correction Factor.....6-96
Correspondence between Mouse Operation and
Keyboard..... 4-5
Crossed-out Wheeled Bin Symbol xii
CRU6-56, 6-67
Current..... 5-6
Current Mask6-108

D

Daily Maintenance 8-2
Data Clock Rate.....6-72
Data Input Method..... 4-5
DCD1-35
DDJ.....1-35
DDJ Histogram6-23
DDJ vs Bit6-25
DDPWS.....1-26
Default Name/Root.....4-11
Define Function.....6-124
Define Threshold6-43
Delete.....6-127
Deleting items6-93
Deleting overwritten waveform display6-78
Differential 50 Ohm5-19
Discarding screen display.....6-81
Display.....6-34
Display status.....4-23
Displaying Software Version..... 8-8
Displaying the system information4-17
Displaying Time and Status.....4-23
Displaying Waveform Calculation.....6-124
Displaying Windows Desktop.....2-24
Disposal8-33
Divide Ratio.....6-71
DJ1-35
DJ (Scale)6-43
Dock/Undock.....4-14
Dual-Dirac BER Bathtub6-18, 6-20
Duty Cycle Distortion.....1-24

E

Earliest Edge 6-25
EC 5-26
ED Input Condition 5-5
Elapsed Time 5-25
Equalizer6-36, 6-44
ER 5-26
Error Addition 5-6
Estimate RJ/DJ Histogram 6-17
Estimate RJ/PJ Histogram..... 6-21
Ethernet connector 2-16
Exit 4-18
Ext Clk 1/16..... 5-7
Ext Clk 1/40 5-7
External Attenuation 5-19
Extinction Ratio..... 1-28
Eye Amplitude 1-28
Eye Center Type 6-37
Eye Crossing Percentage..... 1-28
Eye Crossing Time..... 1-28
Eye Height..... 1-29
Eye Levels..... 1-30
Eye Mask 1-30
Eye Mask Select 6-104, 6-106
Eye Opening Definition 6-38
Eye Pattern..... 1-31
Eye Skews..... 1-32
Eye Width 1-33
Eye Widths 1-30

F

Fall Edges..... 6-23
Fall Samples 6-23
Fall Time 1-42
Features..... 1-17
Fixed RJ..... 6-43
Free Running..... 6-14
Front Panel..... 2-5

G

Gating Current..... 5-23
Gating Cycle 5-6
GPIB Cable Connection..... 2-16

H

Histogram Marker.....6-120
 History Rese5-25
 History Reset..... 5-6
 Hit Count.....6-108
 Hit Ratio6-108
 Hits.....6-120

I

Infinite.....6-77
 Initial Values of PPG/EDB-2
 Initial Values of System MenuB-1
 Initialize4-12
 Initializing measurement conditions.....4-12
 Insert Error5-17
 Inserting Bit Error5-17
 Inserting bit errors one bit at a time using
 screen operation.....5-17
 Insertion Error1-46
 Installation 2-2
 Intended Use1-18
 Internal..... 5-7
 Introduction of BERTWave Series 1-2
 Inverse background color6-129
 ISI.....1-35
 Item Selection.....6-34

J

J2.....6-18, 6-20
 J4.....6-18, 6-20
 J9.....6-18, 6-20
 Jitter.....1-34
 Jitter analysis.....6-88
 Jitter Analysis (Advanced Jitter)6-116
 Jitter Analysis (Eye).....6-115
 Jitter Measure dialog box.....6-40

L

Latest Edge.....6-25
 Length6-74
 Level Skews.....1-36
 Levels p-p1-36
 Levels RMS.....1-36
 Limit Type6-78

Limited 6-77
 Linearity..... 1-37
 Loading measurement conditions from file. 4-10
 Local/Panel Unlock..... 4-12
 Locking the panel operation..... 4-12
 lservrc 8-10

M

Manual Crossing 6-43
 Manual Notation System.....II
 Marker 6-122
 Mask Area Restriction..... 6-110
 Mask File Specifications.....C-2
 Mask Margin1-38, 6-108
 Mask test 6-89
 Mask Test6-47, 6-103
 Mean..... 6-120
 Measurement Edge Type..... 6-40
 Measurement Result 5-25
 Measurement Using Histogram 6-119
 Measuring Waveform 6-88
 Minimize..... 4-14
 Minimizing the screen display 4-14

N

Negative Logic (NEG)..... 5-12
 Noise Margin 1-38
 Notes On Export Management..... xi
 NRZ Amplitude/Time 6-94
 Number of samples..... 6-78
 Number of Samples 6-79
 Numeric value entry panel..... 4-6

O

O/E..... 6-53
 Adjusting 6-86
 Offset6-25, 6-124
 Offset from Crossing..... 6-94
 OK..... 6-129
 OMA 1-38
 Omission Error 1-46
 One Level..... 1-39
 One Shot..... 6-106
 Open 4-10

Index

Optical Connector/Optical Adapter Cleaning 8-5
Optical Modulation Amplitude.....1-38
Option License.....8-10
Optional Accessories.....1-15
OptionLicense.....8-12
Options1-13
Outer Extinction Ratio1-39
Outer OMA.....1-40
Overlap.....6-9
Overshoot1-40

P

PAM4 Amplitude/Time.....6-100
Panel Lock.....4-12
Pattern.....6-25
Pattern Sync.....5-15
PDJ Filter.....6-40
PDJ Measurement.....6-40
PDJ vs Bit.....6-25
Performance Test for Error Detector.....7-12
Performance Test for Sampling oscilloscope 7-23
Performance Test Record Form
 Error Detector.....D-5
 Sampling Oscilloscope.....D-9
Persistency6-77
Pertial Noise Margin.....1-40
PJ.....1-35
PJ Calculate6-24
PJ vs Frequency6-24
Positive Logic (POS)5-12
Power Configuration.....2-22
Power Excursion.....1-41
Power Requirements2-13
Power-off.....2-23
Power-on.....2-22
p-p.....1-40
P-P6-120
PPG Amplitude.....5-5
PPG Data/XData5-5
PPG/ED5-3
PRBS1-42

Q

Quick Menu6-8, 6-85

R

Rate6-55
RCM Conformity Marking.....xix
Rear Panel2-12
Recommended storage conditions.....8-32
Reference CLK.....5-6
reference trace6-125
Remaining Time5-25
Remote Control.....4-15
Repackaging8-33
Repeat.....5-22
Replacement of Optical Connector8-3
Result Window.....6-3, 6-14
Rise Edges6-23
Rise Samples6-23
Rise Time.....1-42
Rise/Fall Time6-35, 6-96
Rise/Fall Time Correction.....6-96
RJ.....1-35
RJ (rms).....6-43
RJ (Scale).....6-43
RJ Value6-43
RJ/PJ Histogram6-21
RMS.....1-43

S

s2p format.....C-5
s4p format.....C-6
Sample.....6-78
Sampling Oscilloscope1-44
Sampling Timing6-37
Save4-9
Save To Clipboard4-17
Save To File4-17
Saving measurement conditions and
 measurement results4-9
Saving Measurement Result6-127
Saving screenshots as image files4-11
Scale6-124
Scale Offset.....6-52
Scope Panel Names2-8
Screen Copy4-11
self test6-66
Set.....6-125

-
- Setting and Displaying Measurement Items 6-90
- Setting Clock Rate and Divide Ratio.....6-73
- Setting Control Panel.....2-24, 2-25
- Setting Error Detection Method.....5-18
- Setting overwritten waveform display6-77
- Setting Pattern Length6-74
- Setting Patterns5-10
- Setting Reference Clock 5-7
- Setting Restrictions.....5-28
- Setting same vertical scale for two waveforms
.....6-86
- Setting Symbol Rate.....6-72
- Setting Sync Output.....5-14
- Setting System Menu 4-8
- Setup/Result 5-5
- Single.....5-22, 6-9
- Single-End Data5-19
- Single-End XData.....5-19
- SNR1-44
- Software Keyboard 4-7
- Standard.....6-40
- Start Time5-25
- Start/Stop 5-6
- Starting data collection6-81
- Starting/finishing Analysis6-117
- Std Dev6-120
- Stopping data collection6-81
- Storage.....8-32
- Symbol Rate1-44
- Sync Loss.....5-24
- Sync Out.....5-6, 5-14
- System Information.....4-17
- System Menu..... 4-8
- System Recovery.....8-15
- T**
- TD data.....6-18, 6-20
- TDEC.....1-45
- TDECQ.....1-46, 6-38
- Technical Terms1-21
- Terminating application.....4-18
- Test Pattern.....5-6, 5-12
- Threshold Level.....5-20
- Tile..... 6-9
- Time..... 6-78
- TJ..... 1-35
- TJ Histogram.....6-17, 6-19
- TJ Measurement BER.....6-18, 6-20, 6-43
- To adjust center power voltage or optical power
at vertical axis..... 6-85
- To change EYE Boundary 6-94
- To display date and time 4-23
- To display measurement area 6-91
- To limit mask area 6-110
- To measure mask margin..... 6-106
- To select channel and mask..... 6-104
- To set Mask Margin and execute mask test
..... 6-107
- To set measurement items 6-91
- To set measurement method of rise/fall time
..... 6-96
- To switch to Eye/Pulse/Coherent Eye mode 6-76
- Top Mask Failed Samples 6-108
- Total Error..... 1-46
- Total Failed Samples..... 6-108
- Total Samples..... 6-108
- Total Waveforms..... 6-108
- Tracking Off..... 6-74
- Transition Time..... 1-46
- Transporting..... 8-33
- Transporting and Destroy 8-33
- Trigger setting wrong..... 6-14
- Turning on external control mode 4-12
- Turning off external control mode..... 4-12
- Turning Power On/Off..... 2-22
- U**
- UKCA Marking..... xviii
- Undershoot 1-47
- Unlocking the panel 4-12
- Unpacking 2-2
- Untimed..... 5-22
- Update 6-109
- Using Marker 6-122
- Using Trace Memory 6-125
- Utilities.....6-125, 6-126

V

VECP1-47

VMA.....1-47

W

Waveform6-78

Waveform display area..... 6-7

Waveforms Color6-129

Waveforms only6-129

Width.....6-94, 6-110

Window Configuration 4-2

Z

Zero Level.....1-47

Zoom In.....6-25

Zoom Out.....6-25