

MP2100B BERTWave Operation Manual

Second Edition

**For safety and warning information, please read this manual before attempting to use the equipment.
Keep this manual with the equipment.**

ANRITSU CORPORATION

Safety Symbols

To prevent the risk of personal injury or loss related to equipment malfunction, Anritsu Corporation uses the following safety symbols to indicate safety-related information. Ensure that you clearly understand the meanings of the symbols BEFORE using the equipment. Some or all of the following symbols may be used on all Anritsu equipment. In addition, there may be other labels attached to products that are not shown in the diagrams in this manual.

Symbols used in manual



DANGER

This indicates a very dangerous procedure that could result in serious injury or death if not performed properly.



WARNING

This indicates a hazardous procedure that could result in serious injury or death if not performed properly.



CAUTION

This indicates a hazardous procedure or danger that could result in light-to-severe injury, or loss related to equipment malfunction, if proper precautions are not taken.

Safety Symbols Used on Equipment and in Manual

The following safety symbols are used inside or on the equipment near operation locations to provide information about safety items and operation precautions. Ensure that you clearly understand the meanings of the symbols and take the necessary precautions BEFORE using the equipment.



This indicates a prohibited operation. The prohibited operation is indicated symbolically in or near the barred circle.



This indicates an obligatory safety precaution. The obligatory operation is indicated symbolically in or near the circle.



This indicates a warning or caution. The contents are indicated symbolically in or near the triangle.



This indicates a note. The contents are described in the box.



These indicate that the marked part should be recycled.

MP2100B BERTWave
Operation Manual

4 September 2015 (First Edition)
15 October 2015 (Secind Edition)

Copyright © 2015, ANRITSU CORPORATION.

All rights reserved. No part of this manual may be reproduced without the prior written permission of the publisher.

The contents of this manual may be changed without prior notice.

Printed in Japan

For Safety

WARNING



- ALWAYS refer to the operation manual when working near locations at which the alert mark shown on the left is attached. If the advice in the operation manual is not followed, there is a risk of personal injury or reduced equipment performance. The alert mark shown on the left may also be used with other marks and descriptions to indicate other dangers.
- Overvoltage Category
This equipment complies with overvoltage category II defined in IEC 61010. DO NOT connect this equipment to the power supply of overvoltage category III or IV.
- Laser radiation warning
 - NEVER look directly into the cable connector on the equipment nor into the end of a cable connected to the equipment. There is a risk of injury if laser radiation enters the eye.
 - The Laser Safety label is attached to the equipment for safety use as indicated in "Laser Safety" later in this section.

Electric Shock

- To ensure that the equipment is grounded, always use the supplied 3-pin power cord, and insert the plug into an outlet with a ground terminal. If power is supplied without grounding the equipment, there is a risk of receiving a severe or fatal electric shock or causing damage to the internal components.

Repair



- Only qualified service personnel with a knowledge of electrical fire and shock hazards should service this equipment. This equipment cannot be repaired by the operator. DO NOT attempt to remove the equipment covers or unit covers or to disassemble internal components. There are high-voltage parts in this equipment presenting a risk of severe injury or fatal electric shock to untrained personnel. In addition, there is a risk of damage to precision components.

For Safety

WARNING

Calibration



- The performance-guarantee seal verifies the integrity of the equipment. To ensure the continued integrity of the equipment, only Anritsu service personnel, or service personnel of an Anritsu sales representative, should break this seal to repair or calibrate the equipment. Be careful not to break the seal by opening the equipment or unit covers. If the performance-guarantee seal is broken by you or a third party, the performance of the equipment cannot be guaranteed.

Falling Over

- This equipment should always be positioned in the correct manner. If the cabinet is turned on its side, etc., it will be unstable and may be damaged if it falls over as a result of receiving a slight mechanical shock.
Always set up the equipment in a position where the power switch can be reached without difficulty.

LCD

- This equipment uses a Liquid Crystal Display (LCD). DO NOT subject the equipment to excessive force or drop it. If the LCD is subjected to strong mechanical shock, it may break and liquid may leak.
This liquid is very caustic and poisonous.
DO NOT touch it, ingest it, or get in your eyes. If it is ingested accidentally, spit it out immediately, rinse your mouth with water and seek medical help. If it enters your eyes accidentally, do not rub your eyes, rinse them with clean running water and seek medical help. If the liquid gets on your skin or clothes, wash it off carefully and thoroughly.
-

For Safety



CAUTION

Cleaning

- Always remove the main power cable from the power outlet before cleaning dust around the power supply and fan.
 - Clean the power inlet regularly. If dust accumulates around the power pins, there is a risk of fire.
 - Keep the cooling fan clean so that the ventilation holes are not obstructed. If the ventilation is obstructed, the cabinet may overheat and catch fire.

Check Terminal



- Never input a signal of more than the indicated value between the measured terminal and ground. Input of an excessive signal may damage the equipment.
-

For Safety

Laser Safety

Class 1 indicates the danger degree of the laser radiation specified below according to IEC 60825-1:2007.

Class 1: Lasers that are safe under reasonably foreseeable conditions of operation, including the use of optical instruments for intrabeam viewing.

Class I indicates the degree of danger of the laser radiation outlined below as defined by 21 CFR 1040.10:1995.

Class I: Class I levels of laser radiation are not considered to be hazardous.



WARNING

The laser in this equipment is classified as Class 1 according to the IEC 60825-1:2007 standard, or as Class I according to the 21 CFR 1040.10:1995 standard.



CAUTION

Use of controls or adjustments or performance of procedures other than those specified herein may result in hazardous radiation exposure.

The use of optical instruments with this product will increase eye hazard.

For Safety

Laser Safety

The model names of “Anritsu-recommended SFP/SFP+” written on label are listed in Table 1.

Table 1 Laser Safety Classifications Based on IEC 60825-1:2007

Model Name	Class	Max. Optical Output Power (mW)*	Pulse Width (s)/ Repetition Rate	Emitted Wavelength (nm)	Beam Radiation Angle (deg.)	Laser Aperture
G0177A	1	0.56	CW	850	23.0	Figure 2 [1]
G0178A	1	1.0	CW	1310	11.5	Figure 2 [1]
G0179A	1	1.0	CW	1550	11.5	Figure 2 [1]
G0238A	1	0.8	CW	850	23.0	Figure 2 [1]
G0239A	1	1.12	CW	1310	11.5	Figure 2 [1]

*: Indicates the possible optical output power when each and every reasonably foreseeable single-fault condition is included.

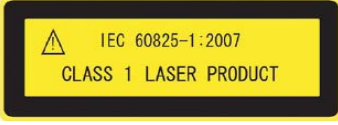

Table 2 Specifications of Laser Built into MP2100B

Model Name	Max. Optical Output Power (mW)*	Pulse Width (s)/ Repetition Rate	Emitted Wavelength (nm)	Beam Radiation Angle (deg.)
G0177A	0.56	CW	850	23.0
G0178A	1.0	CW	1310	11.5
G0179A	1.0	CW	1550	11.5
G0238A	0.8	CW	850	23.0
G0239A	1.12	CW	1310	11.5

*: Maximum output power is the estimated value when something breaks down.

For Safety

Table3 Labels on Product

	Type	Label	Location	Model Name
1	Explanation		Figure 1, A	MP2100B and MP2100B-051
2	Certification		Figure 1, B	MP2100B and MP2100B-051
3	Identification		Figure 1, C	MP2100B and MP2100B-051

For Safety

Laser Radiation Markings

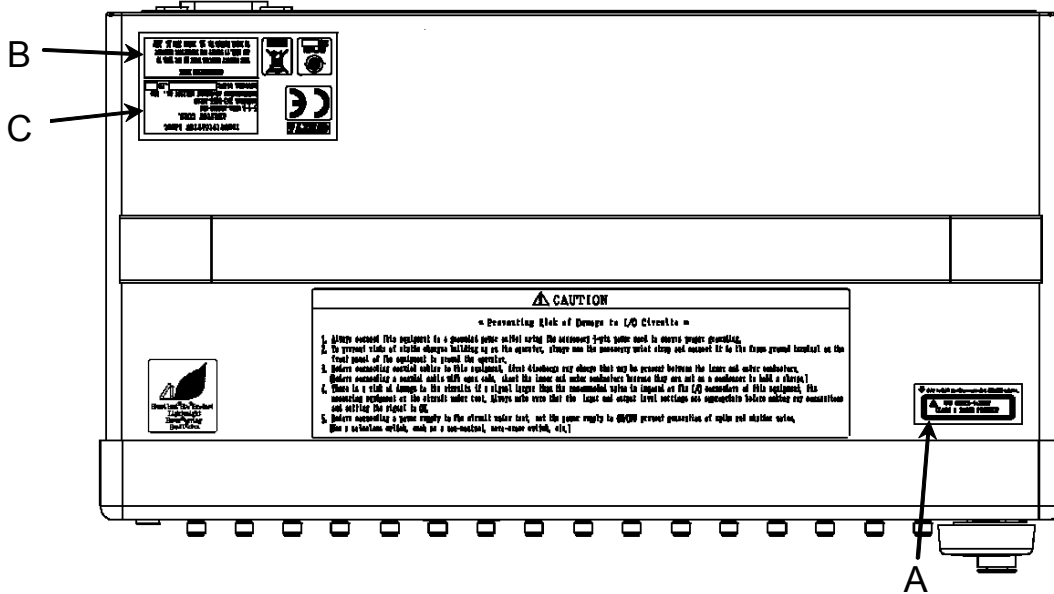

Figure 1 Locations of Labels (Top View)

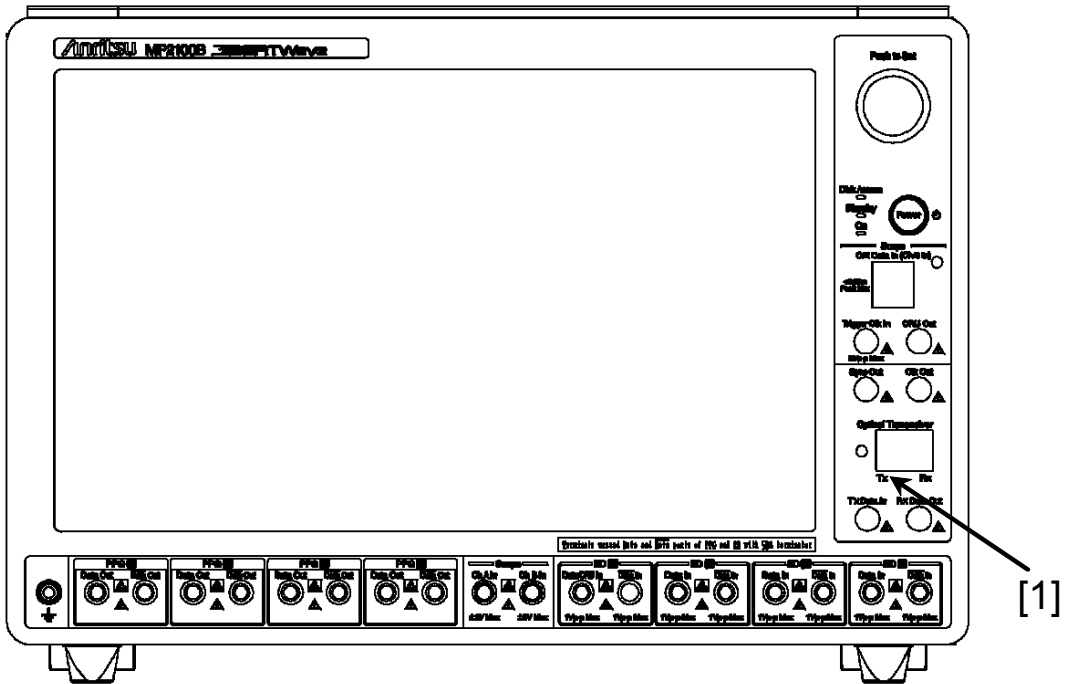

Figure 2 Location of Laser Aperture

For Safety



CAUTION

Replacing Memory Back-up Battery

This equipment uses a Poly-carbon fluoride lithium battery to backup the memory. This battery must be replaced by service personnel when it has reached the end of its useful life; contact the Anritsu sales section or your nearest representative.

Note: The battery used in this equipment has a maximum useful life of 2 years. It should be replaced before this period has elapsed.

External Storage Media

This equipment uses USB memory devices as external storage media for storing data and programs.

If this media is mishandled or becomes faulty, important data may be lost. To prevent this chance occurrence, all important data and programs should be backed-up.

Anritsu will not be held responsible for lost data.

Pay careful attention to the following points.

- Never remove the USB memory device from the instrument while it is being accessed.
 - The USB memory device may be damaged by static electric charges.
 - Anritsu has thoroughly tested all external storage media such as USB memory, Hard disk drive and DVD drive. Users should note that external storage media may not have been tested by Anritsu, thus Anritsu cannot guarantee the performance or suitability of such media.
-

For Safety



CAUTION

Flash Memory

The instrument is equipped with an internal memory from which, as with any flash memory, data may be lost because of limitation of writing times. The writing limitation of flash memory is approximately one million.

Anritsu will not be held responsible for lost data.

Note: The flash memory used in this equipment has a maximum writing time of one million.

Anritsu can take no responsibility for lost data, and users are recommended to always back up important data at regular intervals. To reduce the possibility of data loss, particular attention should be given to the following points.

- The instrument should only be used within the recommend temperature range, and should not be used in locations where the temperature may fluctuate suddenly.
- Always follow the guidelines to ensure that the instrument is set up in the specified manner.
- Always ensure that the fans at the rear and side of the instrument are not blocked or obstructed in any way.
- Exercise care not to bang or shake the instrument while the power is on.
- Never disconnect the mains power at the plug or cut the power at the breaker with the instrument turned on.

Use in a residential environment

This instrument is designed for an industrial environment. In a residential environment this instrument may cause radio interference in which case the user may be required to take adequate measures.

Use in Corrosive Atmospheres

Exposure to corrosive gases such as hydrogen sulfide, sulfurous acid, and hydrogen chloride will cause faults and failures. Note that some organic solvents release corrosive gases.

Equipment Certificate

Anritsu Corporation certifies that this equipment was tested before shipment using calibrated measuring instruments with direct traceability to public testing organizations recognized by national research laboratories, including the National Institute of Advanced Industrial Science and Technology, and the National Institute of Information and Communications Technology, and was found to meet the published specifications.

Anritsu Warranty

Anritsu Corporation will repair this equipment free-of-charge if a malfunction occurs within one year after shipment due to a manufacturing fault. However, software fixes will be made in accordance with the separate Software End-User License Agreement. Moreover, Anritsu Corporation will deem this warranty void when:

- The fault is outside the scope of the warranty conditions separately described in the operation manual.
- The fault is due to mishandling, misuse, or unauthorized modification or repair of the equipment by the customer.
- The fault is due to severe usage clearly exceeding normal usage.
- The fault is due to improper or insufficient maintenance by the customer.
- The fault is due to natural disaster, including fire, wind, flooding, earthquake, lightning strike, or volcanic ash, etc.
- The fault is due to damage caused by acts of destruction, including civil disturbance, riot, or war, etc.
- The fault is due to explosion, accident, or breakdown of any other machinery, facility, or plant, etc.
- The fault is due to use of non-specified peripheral or applied equipment or parts, or consumables, etc.
- The fault is due to use of a non-specified power supply or in a non-specified installation location.
- The fault is due to use in unusual environments^(Note).
- The fault is due to activities or ingress of living organisms, such as insects, spiders, fungus, pollen, or seeds.

In addition, this warranty is valid only for the original equipment purchaser. It is not transferable if the equipment is resold.

Anritsu Corporation shall assume no liability for injury or financial loss of the customer due to the use of or a failure to be able to use this equipment.

Note:

For the purpose of this Warranty, "unusual environment" means use:

- In places of direct sunlight
- In dusty places
- Outdoors
- In liquids, such as water, oil, or organic solvents, and medical fluids, or places where these liquids may adhere
- In salty air or in places where chemically active gases (sulfur dioxide, hydrogen sulfide, chlorine, ammonia, nitrogen oxide, or hydrogen chloride etc.) are present
- In places where high-intensity static electric charges or electromagnetic fields are present
- In places where abnormal power voltages (high or low) or instantaneous power failures occur
- In places where condensation occurs
- In the presence of lubricating oil mists
- In places at an altitude of more than 2,000 m
- In the presence of frequent vibration or mechanical shock, such as in cars, ships, or airplanes

Anritsu Corporation Contact

In the event that this equipment malfunctions, contact an Anritsu Service and Sales office. Contact information can be found on the last page of the printed version of this manual, and is available in a separate file on the CD version.

Notes On Export Management

This product and its manuals may require an Export License/Approval by the Government of the product's country of origin for re-export from your country.

Before re-exporting the product or manuals, please contact us to confirm whether they are export-controlled items or not.

When you dispose of export-controlled items, the products/manuals need to be broken/shredded so as not to be unlawfully used for military purpose.

Lifetime of Parts

The life span of certain parts used in this instrument is determined by the operating time or the power-on time. Due consideration should be given to the life spans of these parts when performing continuous operation over an extended period. These parts must be replaced at the customer's expense even if within the guaranteed period described in Warranty at the beginning of this manual.

Coaxial switch: 10 million counts (switching count for Low-pass filter)

LCD: 50,000 hours

Crossed-out Wheeled Bin Symbol

Equipment marked with the Crossed-out Wheeled Bin Symbol complies with council directive 2012/19/EC (the “WEEE Directive”) in European Union.



For Products placed on the EU market after August 13, 2005, please contact your local Anritsu representative at the end of the product's useful life to arrange disposal in accordance with your initial contract and the local law.

Software End-User License Agreement (EULA)

Please read this Software End-User License Agreement (hereafter this EULA) carefully before using (includes executing, copying, registering, etc.) this software (includes programs, databases, scenarios, etc., used to operate, set, etc., Anritsu electronic equipment). By reading this EULA and using this software, you are agreeing to be bound by the terms of its contents and Anritsu Corporation (hereafter Anritsu) hereby grants you the right to use this Software with the Anritsu-specified equipment (hereafter Equipment) for the purposes set out in this EULA.

1. Grant of License and Limitations

1. Regardless of whether this Software was purchased from or provided free-of-charge by Anritsu, you agree not to rent, lease, lend, or otherwise distribute this Software to third parties and further agree not to disassemble, recompile, reverse engineer, modify, or create derivative works of this Software.
2. You may make one copy of this Software for backup purposes only.
3. You are not permitted to reverse engineer this software.
4. This EULA allows you to install one copy of this Software on one piece of Equipment.

2. Disclaimers

To the extent not prohibited by law, in no event shall Anritsu be liable for personal injury, or any incidental, special, indirect or consequential damages whatsoever, including, without limitation, damages for loss of profits, loss of data, business interruption or any other commercial damages or losses, arising out of or related to your use or inability to use this Software.

3. Limitation of Liability

- a. If a fault (bug) is discovered in this Software, preventing operation as described in the operation manual or specifications whether or not the customer uses this software as described in the manual, Anritsu shall at its own discretion, fix the bug, or exchange the software, or suggest a workaround, free-of-charge. However, notwithstanding

the above, the following items shall be excluded from repair and warranty.

- i) If this Software is deemed to be used for purposes not described in the operation manual or specifications.
 - ii) If this Software is used in conjunction with other non-Anritsu-approved software.
 - iii) Recovery of lost or damaged data.
 - iv) If this Software or the Equipment has been modified, repaired, or otherwise altered without Anritsu's prior approval.
 - v) For any other reasons out of Anritsu's direct control and responsibility, such as but not limited to, natural disasters, software virus infections, etc.
- b. Expenses incurred for transport, hotel, daily allowance, etc., for on-site repairs by Anritsu engineers necessitated by the above faults shall be borne by you.
 - c. The warranty period for faults listed in article 3a above covered by this EULA shall be either 6 months from the date of purchase of this Software or 30 days after the date of repair, whichever is longer.

4. Export Restrictions

You may not use or otherwise export or re-export directly or indirectly this Software except as authorized by Japanese and United States law. In particular, this software may not be exported or re-exported (a) into any Japanese or US embargoed countries or (b) to anyone on the Japanese or US Treasury Department's list of Specially Designated Nationals or the US Department of Commerce Denied Persons List or Entity List. By using this Software, you warrant that you are not located in any such country or on any such list. You also agree that you will not use this Software for any purposes prohibited by Japanese and US law, including, without limitation, the development, design and manufacture or production of missiles or nuclear, chemical or biological weapons of mass destruction.

5. Termination

Anritsu shall deem this EULA terminated if you violate any conditions described herein. This EULA shall also be terminated if the conditions herein cannot be continued for any good reason, such as violation of copyrights, patents, or other laws and ordinances.

6. Reparations

If Anritsu suffers any loss, financial or otherwise, due to your violation of the terms of this EULA, Anritsu shall have the right to seek proportional damages from you.

7. Responsibility after Termination

Upon termination of this EULA in accordance with item 5, you shall cease all use of this Software immediately and shall as directed by Anritsu either destroy or return this Software and any backup copies, full or partial, to Anritsu.

8. Dispute Resolution

If matters of dispute or items not covered by this EULA arise, they shall be resolved by negotiations in good faith between you and Anritsu.

9. Court of Jurisdiction

This EULA shall be interpreted in accordance with Japanese law and any disputes that cannot be resolved by negotiation described in Article 8 shall be settled by the Japanese courts.

Notice

The following actions are strictly prohibited for all of the software installed in this product or otherwise provided by Anritsu:

1. Copying, except for archival purposes.
2. Transferring to a third party separately from this product.
3. Analyzing the incorporated software including but not limited to modifying, decompiling, disassembling, and reverse engineering.

Cautions against computer virus infection

- Copying files and data
Only files that have been provided directly from Anritsu or generated using Anritsu equipment should be copied to the instrument.
All other required files should be transferred by means of USB or CompactFlash media after undergoing a thorough virus check.
- Adding software
Do not download or install software that has not been specifically recommended or licensed by Anritsu.
- Network connections
Ensure that the network has sufficient anti-virus security protection in place.

CE Conformity Marking

Anritsu affixes the CE conformity marking on the following product(s) in accordance with the Council Directive 93/68/EEC to indicate that they conform to the EMC and LVD directive of the European Union (EU).

CE marking



1. Product Model

Model: MP2100B BERTWave

2. Applied Directive

EMC: Directive 2004/108/EC

LVD: Directive 2006/95/EC

3. Applied Standards

- EMC: Emission: EN 61326-1: 2013 (Class A)
Immunity: EN 61326-1: 2013 (Table 2)

	Performance Criteria*
IEC 61000-4-2 (ESD)	B
IEC 61000-4-3 (EMF)	A
IEC 61000-4-4 (Burst)	B
IEC 61000-4-5 (Surge)	B
IEC 61000-4-6 (CRF)	A
IEC 61000-4-11 (V dip/short)	B, C

*: Performance Criteria

A: The equipment shall continue to operate as intended during and after the test. No degradation of performance or loss of function is allowed below a performance level specified by the manufacturer, when the equipment is used as intended. The performance level may be replaced by a permissible loss of performance. If the minimum performance level or the permissible performance loss is not specified by the manufacturer, either of these may be derived from the product description and documentation and what the user may reasonably expect from the equipment if used as intended.

- B: The equipment shall continue to operate as intended after the test. No degradation of performance or loss of function is allowed below a performance level specified by the manufacturer, when the equipment is used as intended. The performance level may be replaced by a permissible loss of performance. During the test, degradation of performance is however allowed. No change of actual operating state or stored data is allowed. If the minimum performance level or the permissible performance loss is not specified by the manufacturer, either of these may be derived from the product description and documentation and what the user may reasonably expect from the equipment if used as intended.
- C: Temporary loss of function is allowed, provided the function is self-recoverable or can be restored by the operation of the controls.

Harmonic current emissions:

EN 61000-3-2: 2006 +A1:2009 A2:2009

(Class A equipment)

: No limits apply for this equipment with an active input power under 75 W.

- LVD: EN 61010-1: 2010 (Pollution Degree 2)

4. Authorized representative

Name: Murray Coleman
Head of Customer Service EMEA
ANRITSU EMEA Ltd.

Address, city: 200 Capability Green, Luton
Bedfordshire, LU1 3LU

Country: United Kingdom

C-Tick Conformity Marking

Anritsu affixes the C-Tick mark on the following product(s) in accordance with the regulation to indicate that they conform to the EMC framework of Australia/New Zealand.

C-Tick marking



1. Product Model

Model: MP2100B BERTWave

2. Applied Standards

EMC: Emission: EN 61326-1: 2013 (Class A equipment)

About Eco Label



The label shown on the left is attached to Anritsu products meeting our environmental standards.

Details about this label and the environmental standards are available on the Anritsu website at <http://www.anritsu.com>

About This Manual

The manual set for the BERTWave Series consists of the following five operation manuals:

MP2100B BERTWave Operation Manual
Operation (M-W3772AE) (This Manual)

This manual is intended for those who use the MP2100B BERTWave, and explains the installation procedure, handling precautions, connector connection procedures, panel operations, maintenance procedures, specifications and various functions.

MP2100A/MP2101A/MP2102A BERTWave
Operation Manual Operation (M-W3349AE)

This manual is intended for those who use the MP2100A/MP2101A/MP2102A BERTWave, and explains the installation procedure, handling precautions, connector connection procedures, panel operations, maintenance procedures, specifications and various functions.

BERTWave series Remote Control
Operation Manual (M-W3773AE)

This manual explains the commands to control the BERTWave, status register structure, and sample programs.

MX210001A Jitter Analysis Software
Operation Manual (M-W3569AE)

This manual explains the operation method and remote control commands for the MX210001A Jitter Analysis Software.

MX210002A Transmission Analysis Software
Operation Manual (M-W3571AE)

This manual explains the operation method and remote control commands for the MX210002A Transmission Analysis Software.

This operation manual assumes the reader has the following basic knowledge:

- Optical communications, handling optical parts
- Windows file operations and the Windows Control Panel

Manual Notation System

The MP2100B BERTWave is referred to as the BERTWave in this manual.

The names of panel and function keys are in bold.

Example: **Power**:

The user interface such as button and tag names are in square brackets.

Example: [PPG], [System Menu]

Table of Contents

For Safety iii

About This Manual I

Chapter 1 Outline 1-1

- 1.1 Introduction of BERTWave 1-2
- 1.2 Configuration 1-3
- 1.3 Features 1-8
- 1.4 Intended Use 1-9
- 1.5 Technical Terms 1-13
- 1.6 Abbreviations 1-23

Chapter 2 Before Use 2-1

- 2.1 Unpacking and Installation 2-2
- 2.2 Part Names 2-5
- 2.3 Power Connection 2-10
- 2.4 Connecting Peripheral Devices 2-12
- 2.5 Connecting Remote Control Devices 2-13
- 2.6 Cautions on Handling Optical Fiber Cables 2-14
- 2.7 Connecting Coaxial Cable 2-16
- 2.8 Installing Optical Transceiver 2-17
- 2.9 Turning Power On/Off 2-20
- 2.10 Using Touch Panel and Rotary Knob 2-23
- 2.11 Setting Control Panel 2-24
- 2.12 Using External Monitor 2-26
- 2.13 Configuring Power Options 2-28
- 2.14 Setting Interface for Remote Control 2-29
- 2.15 Precautions for Preventing Damage 2-34
- 2.16 System Recovery Function 2-40

Chapter 3 Connecting with DUT 3-1

- 3.1 Measuring Bit Error Rate 3-2
- 3.2 Measuring Waveform 3-7
- 3.3 Simultaneously Measuring Bit Error Rate and
Waveform 3-12
- 3.4 Measuring QSFP Module Bit Error Rate 3-14

1
2
3
4
5
6
7
8
9
10
Appendix
Index

Chapter 4 Screen Operation..... 4-1

- 4.1 Screen Configuration4-2
- 4.2 Data Input Method4-5
- 4.3 Setting System Menu4-8
- 4.4 Multi-channel Signal Output4-15
- 4.5 Simultaneous Measurement Start and Stop at
Multi-channels.....4-16
- 4.6 Linking Measurement Settings for Multiple Channels.4-17
- 4.7 Displaying BER Measurement Results for Multiple
Channels4-18
- 4.8 Displaying Date/Time and Status4-19
- 4.9 Actions to Take When System Alarm Occurs4-20

Chapter 5 Generating Pulse Signal 5-1

- 5.1 List of Setting Items5-2
- 5.2 Setting Restrictions5-9
- 5.3 Procedure for Generating Pulse Signal.....5-10
- 5.4 Setting Reference Clock.....5-11
- 5.5 Setting Output Waveform5-16
- 5.6 Setting Patterns5-20
- 5.7 Inserting Bit Error.....5-25
- 5.8 Setting Sync Output.....5-26

Chapter 6 Measuring Bit Error 6-1

- 6.1 Function List6-2
- 6.2 Procedure of Measuring Bit Error Rate6-9
- 6.3 Setting Conditions for Error Detection6-10
- 6.4 Setting Measurement Conditions.....6-21
- 6.5 Measurement Result6-24
- 6.6 Saving Measurement Results.....6-25

Chapter 7 Measuring Waveform 7-1

- 7.1 EYE/Pulse Scope Screen.....7-2
- 7.2 Setting Item List.....7-12
- 7.3 Restrictions for Setting Parameters7-22

7.4	Measurement Procedure.....	7-23
7.5	Calibrating Sampling Oscilloscope	7-24
7.6	Setting Clock Recovery and Rate.....	7-28
7.7	Setting Data Collection Method	7-33
7.8	Setting Pattern Length	7-38
7.9	Collecting Data	7-39
7.10	Adjusting Screen Scale	7-41
7.11	Measuring Waveform	7-47
7.12	Using Marker	7-66
7.13	Waveform Math Calculation	7-68
7.14	Using Trace Memory.....	7-69
7.15	Displaying a Label.....	7-70
7.16	Saving Measurement Results.....	7-71
Chapter 8 Operating Optical Interface		8-1
8.1	Optical Interface Types	8-2
8.2	Operating Optical Transceiver.....	8-5
8.3	Operating O/E Converter.....	8-7
Chapter 9 Performance Test		9-1
9.1	Performance Test for Pulse Pattern Generator	9-2
9.2	Performance Test for Error Detector.....	9-8
9.3	Performance Test for Sampling Oscilloscope	9-21
9.4	Performance Test for Optical Interface (O/E Converter)	9-25
Chapter 10 Maintenance		10-1
10.1	Daily Maintenance	10-2
10.2	Replacement of Optical Connector.....	10-3
10.3	Optical Connector/Optical Adapter Cleaning.....	10-5
10.4	Displaying Software Version.....	10-8
10.5	Updating Software	10-10
10.6	Touch Panel Position Calibration.....	10-11
10.7	Calibration	10-13
10.8	Storage.....	10-14
10.9	Transporting and Disposal	10-15

1

2

3

4

5

6

7

8

9

10

Appendix

Index

Appendix A Specifications	A-1
Appendix B Initial Values	B-1
Appendix C Keyboard and Mouse Operations	C-1
Appendix D Pattern Files.....	D-1
Appendix E Performance Test Record Form ..	E-1
Appendix F Bibliography.....	F-1
Index	Index-1

Chapter 1 Outline

This chapter explains the BERTWave types and features, and technical terms used in this manual.

1.1	Introduction of BERTWave	1-2
1.2	Configuration.....	1-3
1.2.1	Standard Configuration	1-3
1.2.2	Options	1-4
1.2.3	Optional Accessories.....	1-6
1.3	Features.....	1-8
1.4	Intended Use.....	1-9
1.5	Technical Terms	1-13
1.6	Abbreviations	1-23

1.1 Introduction of BERTWave

The MP2100B BERTWave is a measuring instrument that combines the functions of a pulse pattern generator (PPG), bit error detector (ED) and sampling oscilloscope all-in-one instrument.

The PPG creates a digital signal with editable data transmission speed, pulse voltage level, and send data pattern.

The ED compares the received data bit string with the expected data a bit string and calculates the number of different bits (bit error count). It calculates the bit error rate from the number of received bits and the bit error account. The voltage level for recognizing 0 and 1 of the digital signal, and the data bit string (pattern) can be edited.

The sampling oscilloscope displays the periodic signal waveform. An Eye diagram can be displayed by summing the signal waveforms and signal waveforms can be analyzed and mask tested.

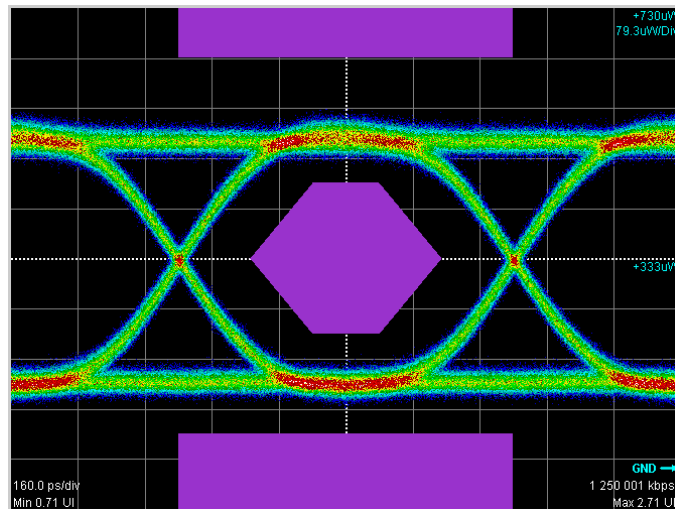

Figure 1.1-1 Mask Test Waveform

1.2 Configuration

1.2.1 Standard Configuration

The following table lists the standard configuration of the BERTWave.

Table 1.2.1-1 Standard Configurations

Item	Model/ Ordering No.	Product Name	Q'ty	Remarks
Main unit	MP2100B	BERTWave	1	
Accessories	MX210000A	BERTWave Control Software (CD-ROM)	1	Contained in accessory box.
		POWER CORD	1	
	J1359A	COAXIAL ADAPTOR (K-P.K-J, SMA)	*	
	J1137	TERMINATOR	*	
	J1341A	OPEN	*	Coaxial connector cover

*: The quantities are the totals provided for each option.

Option Number	J1137	J1341A	J1359A
MP2100B-011	2	5	0
MP2100B-012	4	7	0
MP2100B-014	8	11	0
MP2100B-021	0	3	2
MP2100B-023	0	2	1
MP2100B-051	0	2	0
MP2100B-053	0	2	0
MP2100B-054	0	1	0
MP2100B-055	0	1	0

1.2.2 Options

Option name format

The option number is indicated by three digits.

MP2100B- x x x

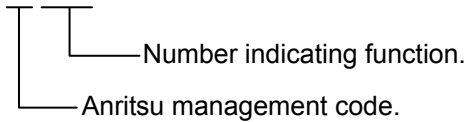

- 0: Installed at time of shipping
- 1: Retro-fitted option.
Must be returned to Anritsu (Japan) when installing.
- 2: Retro-fitted option.
Must be returned to an Anritsu Service and Sales office when installing.
- 3: Software option.
License registration is required when installing.

The MP2100B options are shown below.

The numbers of the options added are indicated on the label on the rear panel.

For details of whether retro-fitted options or software options are included, please refer to the ordering information on the Anritsu website.

<http://www.anritsu.com/en-US/Products-Solutions/Products/MP2100B.aspx>

Table 1.2.2-1 MP2100B Option List

Option Number	Name	Description
MP2100B-011*1,*3	1CH BERT	
MP2100B-012*1,*3	2CH BERT	
MP2100B-014*1,*3	4CH BERT	
MP2100B-021*2,*3	Dual Electrical Scope	
MP2100B-023*2,*3	Optical and Single-ended Electrical Scope	
MP2100B-030	GPIO	Interface for remote control
MP2100B-037*4,*5	FC Connector	Replacement optical connector
MP2100B-040*4,*5	SC Connector	Replacement optical connector
MP2100B-051*6	SFP+ Slot	Slot for installing optical transceiver

- *1: Select one of the Options 011, 012, and 014.
- *2: Select one of the Options 021 or 023.
- *3: Either one or both of the BERT options (011, 012, 014) and scope options (021, 023) must be selected.
- *4: Can be selected with the Option 023.
- *5: Select one of the Options 037 or 040.
- *6: Can be selected with the Option 011, 012, or 014.

Table 1.2.2-1 MP2100B Option List (Cont'd)

Option Number	Name	Description
MP2100B-053*7	Clock Recovery (External Data)	
MP2100B-054*7	Clock Recovery (Optical Data)	
MP2100B-055*7	Clock Recovery (with BER Measurement)	
MP2100B-063*4,*8	High Rate Filter Bank	
MP2100B-065*4,*8	Low Rate Filter Bank	
MP2100B-069*4,*8	Multi Rate Filter Bank	
MP2100B-070*9	LPF for 156M (L)	
MP2100B-071*9	LPF for 622M (L)	
MP2100B-072*9	LPF for 1.0G (L)	
MP2100B-073*9	LPF for 1.2G (L)	
MP2100B-075*9	LPF for 2.5G (L)	
MP2100B-076*10	LPF for 2.1G (H)	
MP2100B-078*10	LPF for 2.6G (H)	
MP2100B-079*10	LPF for 3.1G (H)	
MP2100B-080*10	LPF for 4.2G (H)	
MP2100B-081*10	LPF for 5.0G (H)	
MP2100B-082*10	LPF for 6.2G (H)	
MP2100B-086*10	LPF for Multi 10G (8.5G to 11.3G) (H)	
MP2100B-087*4,*8	Filter Bank Set (622M/1.2G/2.5G/4.2G/6.2G/Multi 10G)	
MP2100B-088*4,*8	Filter Bank Set (4.2G/5.0G/6.2G/ Multi 10G)	
MP2100B-089*4,*8	Filter Bank Set (156M/622M/1.2G/2.5G)	
MP2100B-092*6	PPG/ED Bit Rate Extension for 125M to 12.5G	Extends the setting range of PPG and ED bit rate.
MP2100B-ES310	3-year Warranty Extended Service	
MP2100B-ES510	5-year Warranty Extended Service	

*7: The following table lists the clock recovery option numbers that can be installed depending on the option configuration.

	Option 011, 012, 014	
	Not selected	Selected
Option 021	053	055
Option 023	053, 054	054, 055

*8: Select one of 063, 065, 069, or 087 to 089.

*9: Can be selected with the Option 065 or 069.

*10: Can be selected with the Option 063 or 069.

1.2.3 Optional Accessories

Table 1.2.3-1 shows the optional accessories for BERTWave.

Table 1.2.3-1 Optional Accessories

Model/Order No.	Name	Remarks
MX210001A	Jitter Analysis Software	
MX210002A	Transmission Analysis Software	
B0650A	Rack Mount Kit	
B0716A	Carrying Case	
G0177A	850 nm SFP Module (1.062 to 4.25Gbit/s)	
G0178A	1310 nm SFP Module (0.155 to 2.67Gbit/s)	
G0179A	1550 nm SFP Module (0.155 to 2.67Gbit/s)	
G0238A	SFP+ SR 850 nm	
G0239A	SFP+ LR 1310 nm	
G0307A	Clock Recovery Module (<2.667G)	
G0334A	40G LR4 1310 nm QSFP+	
G0359A	40G SR4 850 nm QSFP+	
G0344F	Optical Switch (1x4, SM9, FC/UPC)	
G0344S	Optical Switch (1x4, SM9, SC/UPC)	
G0345F	Optical Switch (1x16, SM9, FC/UPC)	
G0345S	Optical Switch (1x16, SM9, SC/UPC)	
G0346F	Optical Switch (1x4, GI50, FC/UPC)	
G0346S	Optical Switch (1x4, GI50, SC/UPC)	
G0347F	Optical Switch (1x4, GI62.5, FC/UPC)	
G0347S	Optical Switch (1x4, GI62.5, SC/UPC)	
G0348F	Optical Switch (2x4, GI50, FC/UPC)	
G0348S	Optical Switch (2x4, GI50, SC/UPC)	
G0349F	Optical Switch (2x4, GI62.5, FC/UPC)	
G0349S	Optical Switch (2x4, GI62.5, SC/UPC)	
J0617B	Replaceable optical connector (FC-PC)	
J0618D	Replaceable Optical Connector (ST)	
J0618E	Replaceable Optical Connector (DIN)	
J0619B	Replaceable Optical Connector (SC)	
J1137	Terminator	
J1139A	FC·PC-LC·PC-1M-SM	
J1341A	Open (Coaxial connector cover)	
J1342A	Coaxial Cable 0.8 m	
J1343A	Coaxial Cable 1.0 m	
J1344A	LC·PC-LC·PC-1M-SM	
J1345A	SC·PC-LC·PC-1M-SM	
J1346A	LC·PC-LC·PC-1M-GI (62.5/125)	
J1347A	FC·PC-LC·PC-1M-GI (62.5/125)	
J1348A	SC·PC-LC·PC-1M-GI (62.5/125)	

Table 1.2.3-1 Optional Accessories (Cont'd)

Model/Order No.	Name	Remarks
J1349A	Coaxial Cable 0.3 m	
J1359A	Coaxial Adaptor (K-P.K-J,SMA)	
J1510A	Pick OFF Tee	
J1512A	7.5G Passive Probe Set	
J1519A	Optical Fiber Cord (MM, 12FIBER, MPO, 3M)	
J1680A	4Channel CWDM MUX or DEMUX	
J1681A	MPO Loopback Cable	
J1682A	MPO to FC convert cable	
J1683A	QSFP+ 40Gbps Test Adapters	
J1684A	Single-mode Coupler	
J1685A	Multi-mode Coupler	
W3772AE	MP2100B BERTWave Operation Manual	Printed version
W3773AE	BERTWave Series Remote Control Operation Manual	Printed version
Z0306A	Wrist Strap	
Z0914A	Ferrule Cleaner	
Z0915A	Replacement Reel for Ferrule Cleaner	6 pcs
Z0916A	Ferrule side face cleaner	Stick type (200 pcs)

1.3 Features

The BERTWave has the following features:

- Bit error rate measurement and waveform monitoring in one instrument
- Easy touch panel operation
- Compact size (180 mm deep)
- 4-channel simultaneous BER measurement, handy for QSFP module testing (Option 014)
- GPIB interface option for remote control
- Compatibility of remote commands with previous Anritsu measuring instruments

1.4 Intended Use

The BERTWave can be used for the following applications:

- Evaluating optical transceivers used in optical fiber communications
- Evaluating parts for digital communications

Evaluating optical transceivers used in optical fiber communications

Computer-based and public communications systems send and receive digital signals. These signals are converted to electrical or optical signals optimized for passage through the transmission path, which may be either coaxial cable or optical fiber. The device for converting the signal before sending through the transmission path is called the transmitter and the device for converting the signal after passage through the transmission path is called the receiver.

A device incorporating an optical signal transmitter and receiver in the same module is called an optical transceiver.

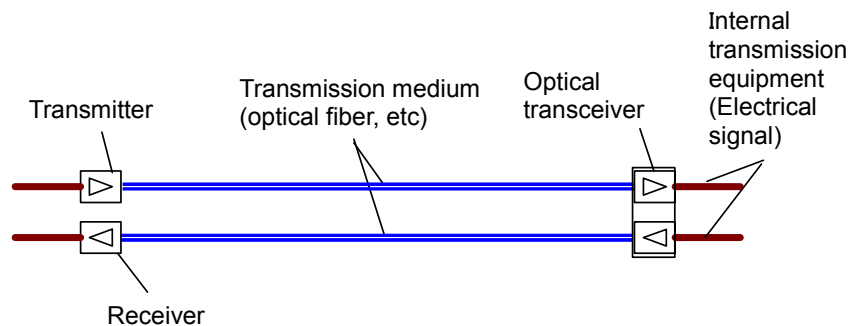

Figure 1.4-1 Uses of Receiver and Transmitter

Transmitters and receivers must have the functions and performance specified by IEEE and ITU-T.

Table 1.4-1 and Table 1.4-2 list the specifications for computer-based Ethernet communications as an example of the required performance and functions. In these tables, the optical fiber transmission medium has a speed of 10 Gbit/s specified as 10GBASE-L.

Table 1.4-1 Transmitter Optical Output

Item	Specifications
Transmission rate	9.95328 Gbit/s \pm 20 ppm (10GBASE-LR) 10.3125 Gbit/s \pm 20 ppm (10GBASE-LW)
Center wavelength	1260 to 1355 nm
Averaging output	-8.5 to 0.5 dBm
Minimum modulation amplitude	-5.2 dBm
Minimum extinction ratio	3.5 dB
Eye mask pattern (X1, X2, X3, Y1, Y2, Y3)	(0.25, 0.40, 0.45, 0.25, 0.28, 0.40)

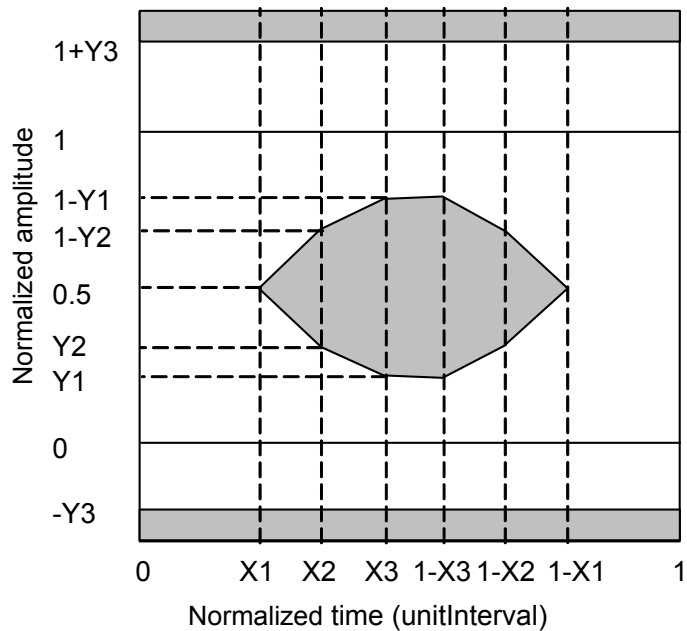

Figure 1.4-2 Definition of Eye Mask Pattern

Table 1.4-2 Receiver Optical Interface

Item	Specifications
Transmission rate	9.95328 Gbit/s \pm 100 ppm (10GBASE-LR) 10.3125 Gbit/s \pm 100 ppm (10GBASE-LW)
Center wavelength	1260 to 1355 nm
Average Rx power	-14.4 to 0.5 dBm
Rx sensitivity based on optical modulation amplitude*	0.093 mW (-10.3 dBm)

*: Bit error rate: 10^{-12} or less

Excluding center wavelength, the items in Table 1.4-1 are tested with the BERTWave.

The following figure shows a connection example between the DUT and the measurement.

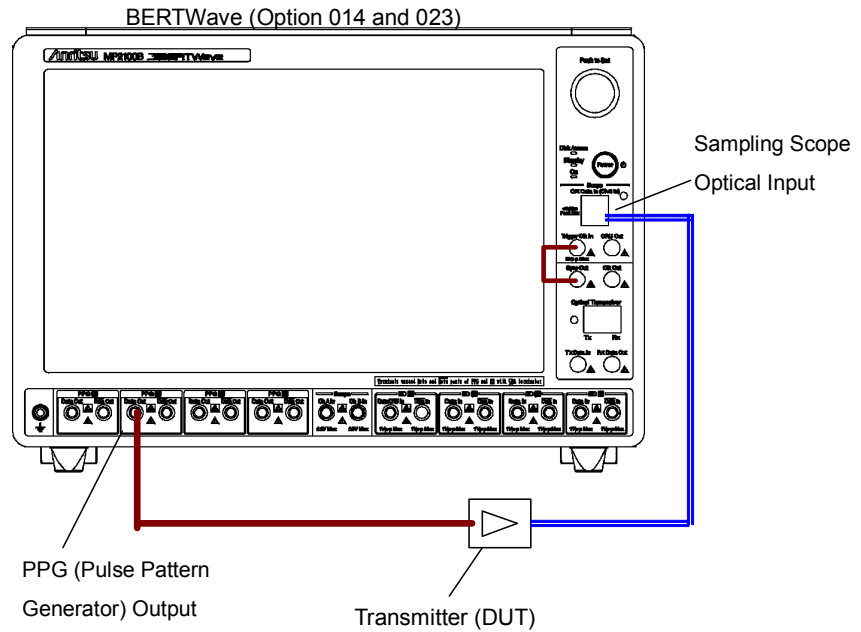

Figure 1.4-3 Transmitter Test Method

The sampling oscilloscope is used to test whether or not the output waveform of the optical transceiver satisfies the standard values in Table 1.4-1.

Excluding center wavelength, the items in Table 1.4-2 are used to test E/O converters, optical power meters, optical attenuator, and optical couplers with the BERTWave.

The following figure shows a connection example for the BERTWave when SFP + module is being measured.

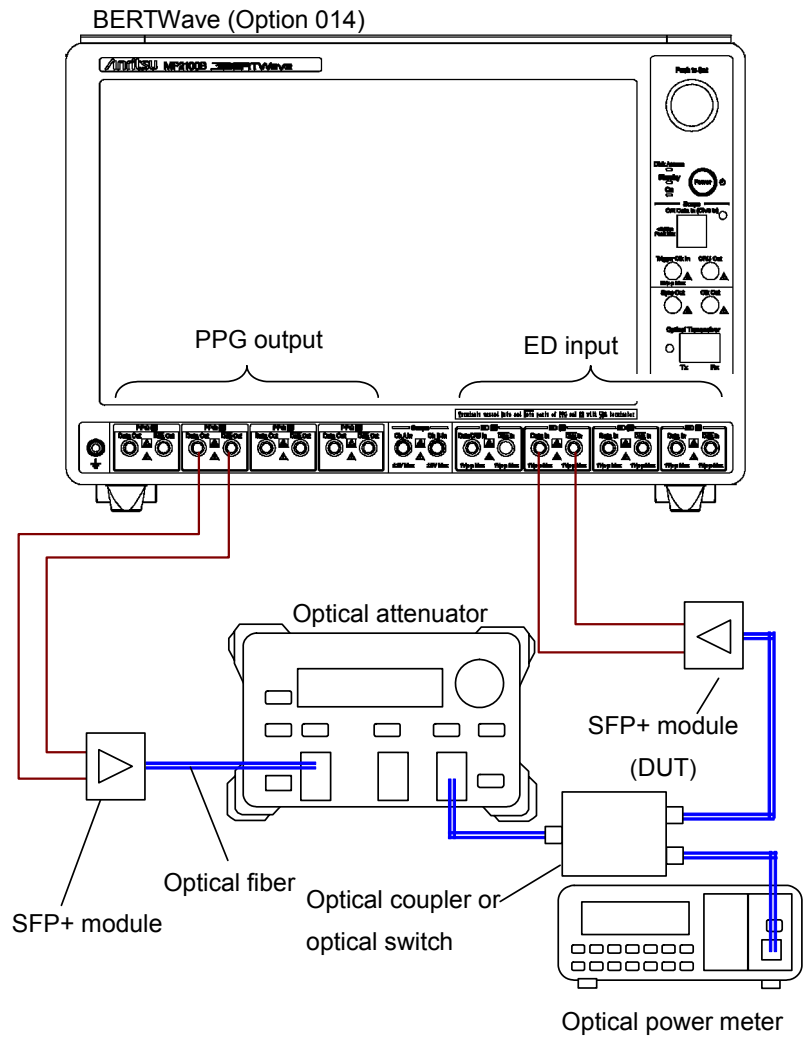

Figure 1.4-4 Receiver Test Method

1.5 Technical Terms

This section explains the technical terms used in this manual.

0 Level (Zero Level)

At Eye pattern measurement, the maximum level at the center 20% of the bit interval is the average value of the low histogram.

1 Level (One Level)

At Eye pattern measurement, the maximum level at the center 20% of the bit interval is the average value of the high histogram.

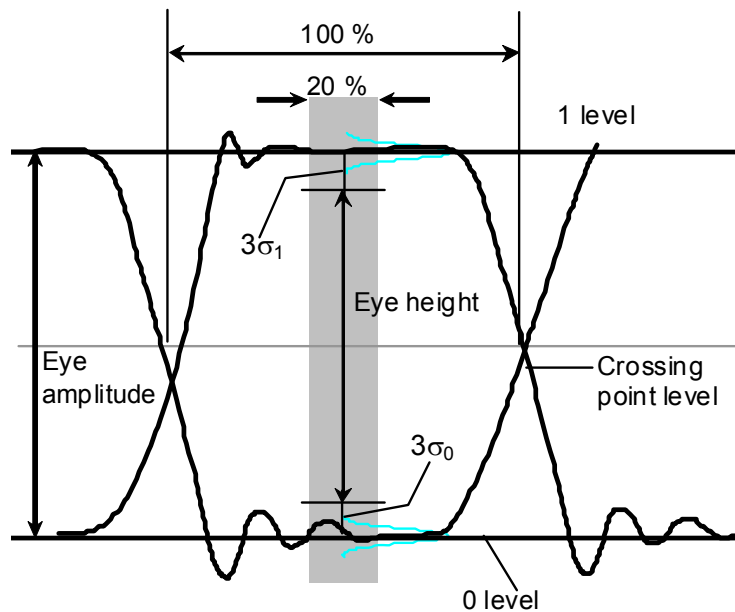

Figure 1.5-1 0 Level, 1 Level, Eye Amplitude and Eye Height

p-p (peak to peak)

Indicates difference between maximum and minimum values for signal amplitude and data distribution width

For example, V_{p-p} means the difference between the maximum and minimum values of the AC voltage.

Jitter p-p means the difference between the maximum and minimum values of the jitter time distribution.

PRBS (Pseudo-Random Bit Sequence)

PRBS is the abbreviation for pseudorandom bit sequence. It is a bit string approximating actual communications data with a random distribution of “1” and “0”. In a bit length of 2^n-1 , n is called the number of the PRBS. Using the BERTWave, n can be set to 7, 9, 15, 23, and 31.

Table 1.5-1 PRBS Bit Length

n	2^n-1
7	127
9	511
15	32767
23	8388607
31	2147483647

The number of the PRBS used for measuring the Rx sensitivity is determined by the communications standard.

RMS (root mean square)

This is the DC voltage consuming the equal power the same as the consumed power when impressing AC voltage on a resistance.

In Voltage, RMS is DC voltage consuming the equal power when AC voltage is impressing on a resistance.

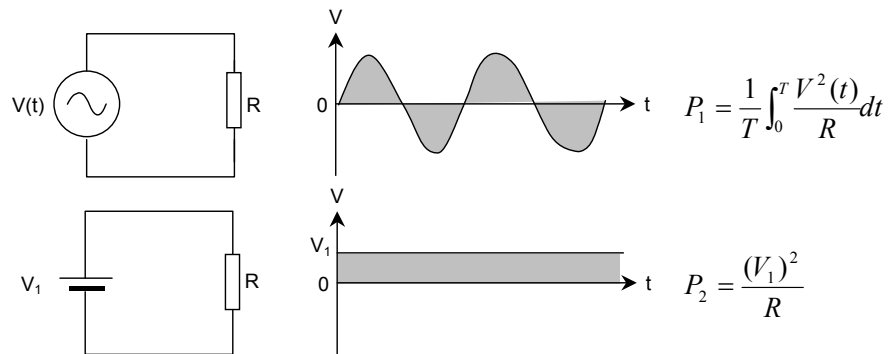

Figure 1.5-2 AC and DC Voltage Power Consumption

In the circuit in Figure 1.5-2, the voltage V_1 when the power P_1 and P_2 consumed by resistance R is equal is the effective AC voltage $V(t)$. V_1 is the root mean square found using the following equation.

$$V_1 = \sqrt{\frac{1}{T} \int_0^T V^2(t) dt}$$

For a sine wave, the ratio of RMS and p-p is $2\sqrt{2}$.

V_{rms} means the effective voltage value.

Jitter rms is expressed as the standard deviation of the jitter time domain histogram.

SNR (Signal to Noise Ratio)

This is the ratio of the signal amplitude to the noise amplitude. The sampling oscilloscope can be calculated by the following formula.

$$\text{SNR} = (1 \text{ Level} - 0 \text{ Level}) / (\sigma_1 + \sigma_0)$$

σ_1 : 1 Level Standard Deviation

σ_0 : 0 Level Standard Deviation

Eye Crossing Percentage

The Eye Crossing Percentage is the ratio of the Eye amplitude rising and falling waveforms. The calculation formula is as follows. Refer to Figure 1.5-1.

$$\text{Crossing} = (\text{crossing point level} - 0 \text{ Level}) / (1 \text{ Level} - 0 \text{ Level})$$

Eye Amplitude

The eye amplitude is the difference between 1 Level and 0 Level. Refer to Figure 1.5-1.

Eye Height

The eye height can be calculated by the following formula. Refer to Figure 1.5-1.

$$\text{Eye Height} = (1 \text{ Level} - 3 \sigma_1) - (0 \text{ Level} + 3 \sigma_0)$$

σ_1 : 1 Level Standard Deviation

σ_0 : 0 Level Standard Deviation

Eye Pattern

The Eye Pattern is the pattern created by superimposing the digital waveforms sampled at the same timing.

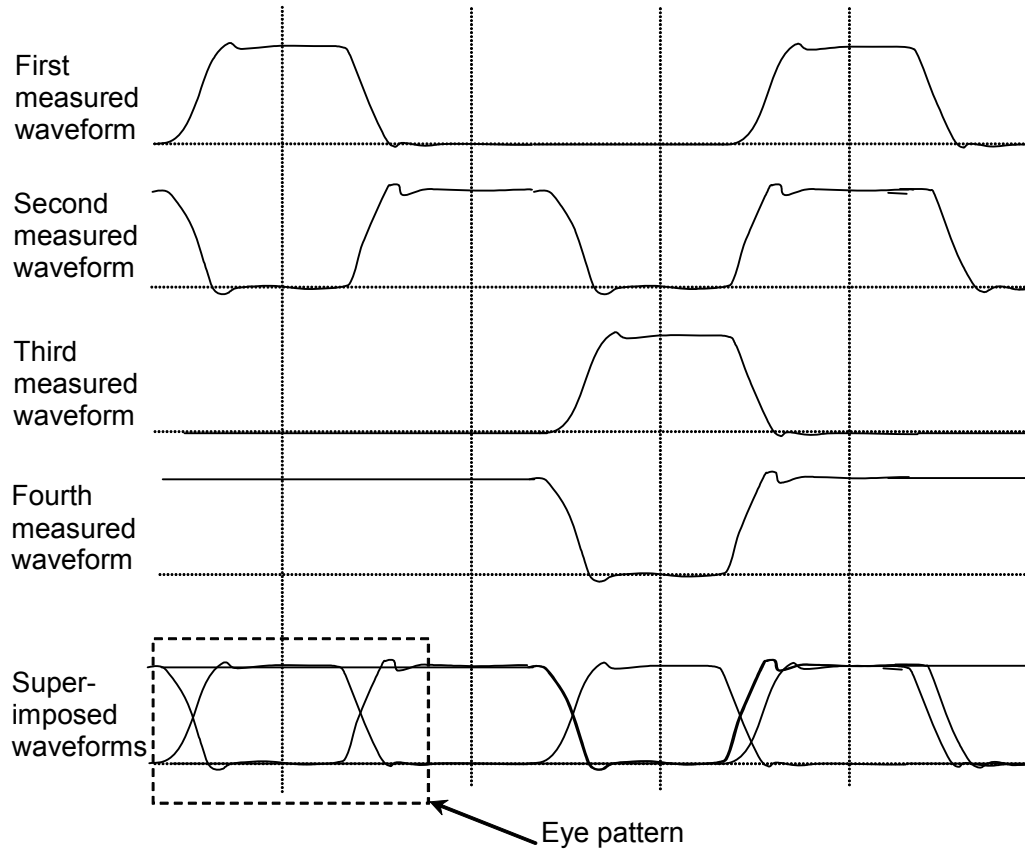

Figure 1.5-3 Eye Pattern Drawing Method

Eye Width

Eye Width is equivalent to Eye Height in the horizontal direction. It is calculated from a histogram of the two eye pattern crossing points in the time direction.

$$\text{Eye Width} = (t_2 - 3\sigma_2) - (t_1 + 3\sigma_1)$$

t_1 : Average time of first crossing point

t_2 : Average time of second crossing point

σ_1 : Standard deviation of first crossing point

σ_2 : Standard deviation of second crossing point

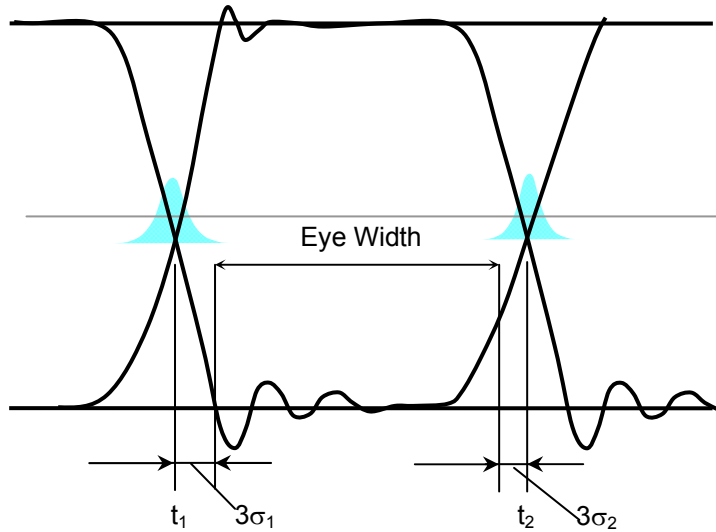

Figure 1.5-4 Eye Width

Eye Mask

The Eye Mask is the boundary of the eye pattern waveform time and amplitude. The value and waveform are specified by the communications standards.

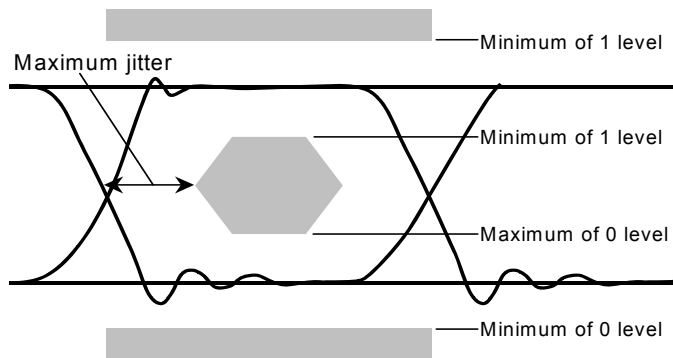

Figure 1.5-5 Example of Eye Mask

Sampling Oscilloscope

The sampling oscilloscope is a function for monitoring the waveform of the input signal. It requires a clock input sampling and the waveform is drawn out of the clock timing. For a periodic signal like PRBS, the waveform data is obtained by slightly varying the sampling timing. This waveform data is drawn by superimposing the waveforms.

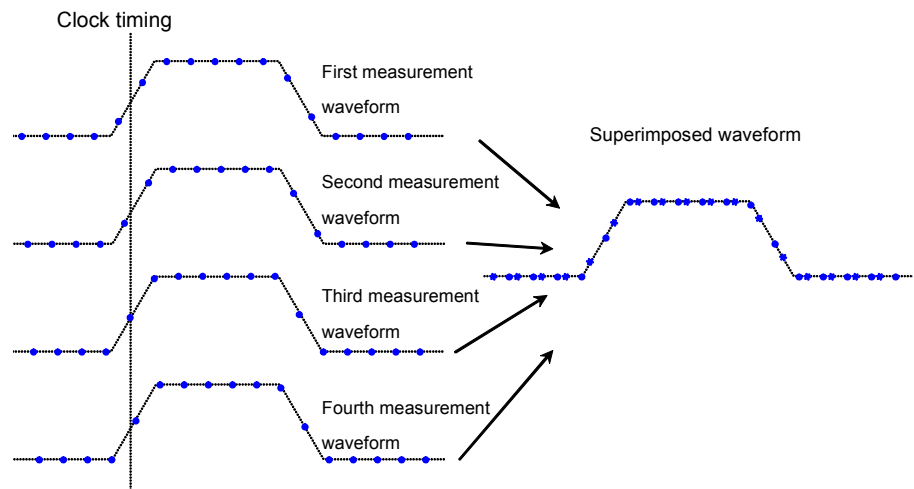

Figure 1.5-6 Drawing Method of Sampling Oscilloscope

Jitter

Jitter is the variation in the time of the crossover point between the Eye Diagram rising and falling parts of the waveform.

Jitter p-p (Jitter p-p): Full width of histogram in time direction

Jitter RMS (Jitter RMS): Standard deviation of histogram in time direction

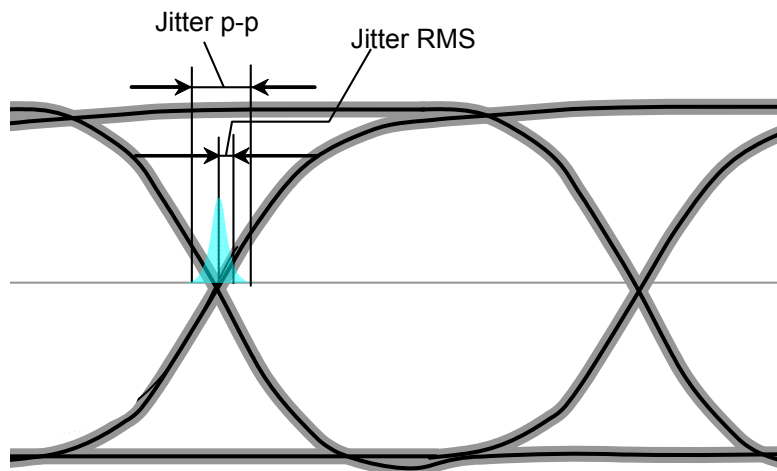

Figure 1.5-7 Jitter p-p and Jitter RMS

Extinction Ratio

The extinction ratio is the ratio of 1 Level and 0 Level; it is used for evaluating optical signal waveforms.

The extinction ratio is calculated by the following formula.

$$\text{Extinction Ratio} = 10\log_{10} \left\{ \frac{(L_1 - L_D)}{(L_0 - L_D)} \right\} \quad (\text{dB})$$

L_1 : 1 Level (mW)

L_0 : 0 Level (mW)

L_D : Level without optical input (mW)

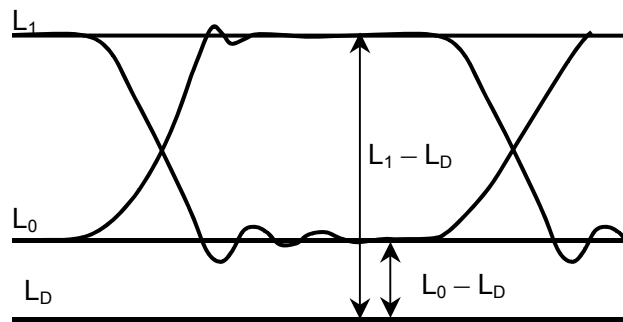

Figure 1.5-8 Extinction Ratio Measurement Level

Duty Cycle Distortion

The duty cycle distortion (DCD) is found from the following equation:

$$\text{DCD} = (t_2 - t_1) / B_p \times 100 \quad (\%)$$

Where,

t_1 : Time at crossing point between Eye Width 50% level and rising waveform

t_2 : Time at crossing point between Eye Width 50% level and falling waveform

B_p : Bit cycle

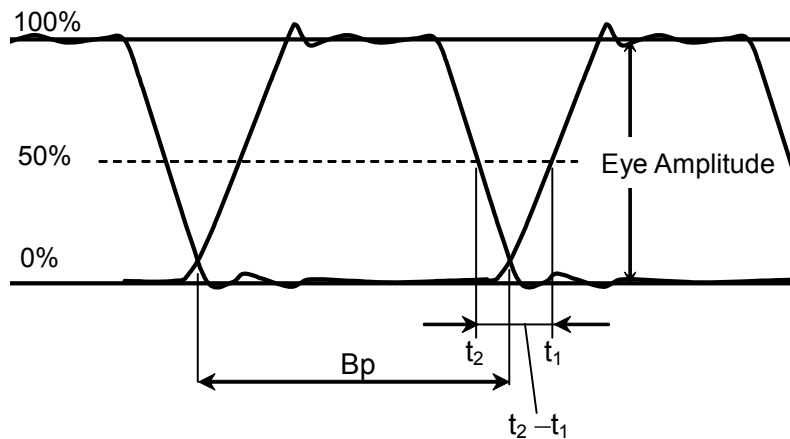

Figure 1.5-9 Duty Cycle Distortion

Rise/Fall Time

The Rise Time is time taken for the signal level to change to the next level.

- From 20% level of amplitude to 80%
- From 10% level of amplitude to 90%

The Fall Time is the time taken for the signal level to change to the next level.

- From 80% level of amplitude to 20%
- From 90% level of amplitude to 10%

For the BERTWave, the rise and fall time measurement level can be selected from either 10/90% or 20/80%.

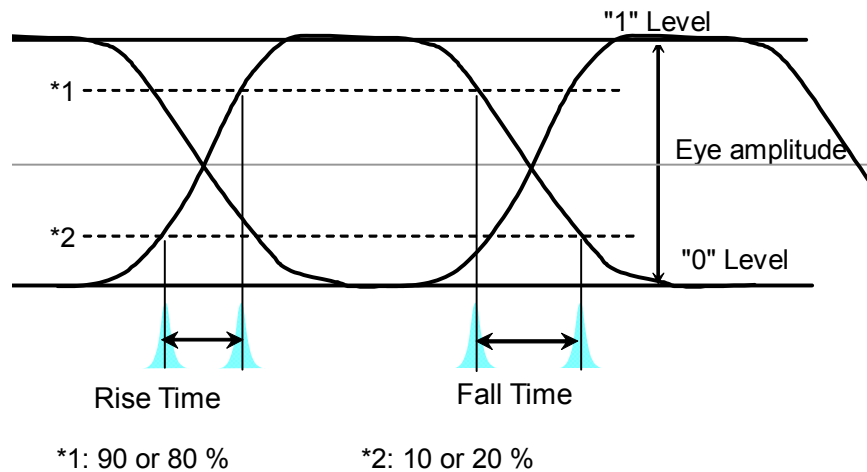

Figure 1.5-10 Rise and Fall Time

Total Error

There are two methods as follows for generating bit errors.

The following bit error count corresponding to the sum of Insertion Error and Omission Error is referred to as the Total Error.

- Signal "1" bits evaluated as "0" bits (Omission Error)
- Signal "0" bits evaluated as "1" bits (Insertion Error)

Optical Modulation Amplitude (OMA)

This indicates a difference at 1 level and 0 levels of the optical waveform. It is the same as Eye Amplitude.

Bit Error Rate

The Bite Error Rate is the ratio of the total received bits and error bits. It depends on the SNR (signal to noise ratio).

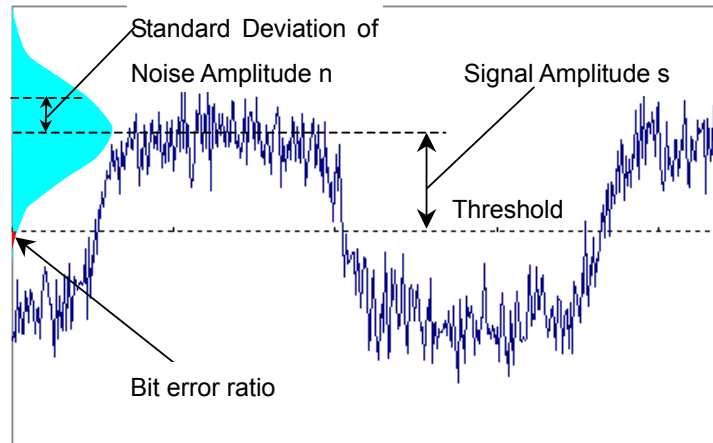

Figure 1.5-11 Bit Error Rate

When the distribution of the noise voltage amplitude is assumed to follow a normal distribution, the standard deviation is assumed to be n and the signal amplitude is s . Bit errors occur when the noise amplitude is larger than the signal amplitude. Consequently, the probability of amplitude occurring is the bit error ratio.

The bit error ratio, BER, is calculated by the following formula.

$$BER = \frac{1}{\sqrt{2\pi}} \int_{s/n}^{\infty} \exp\left(-\frac{x^2}{2}\right) dx$$

When the SNR is large (greater than 4), the relationship between SNR and BER becomes linear when plotted on a semi-logarithmic graph.

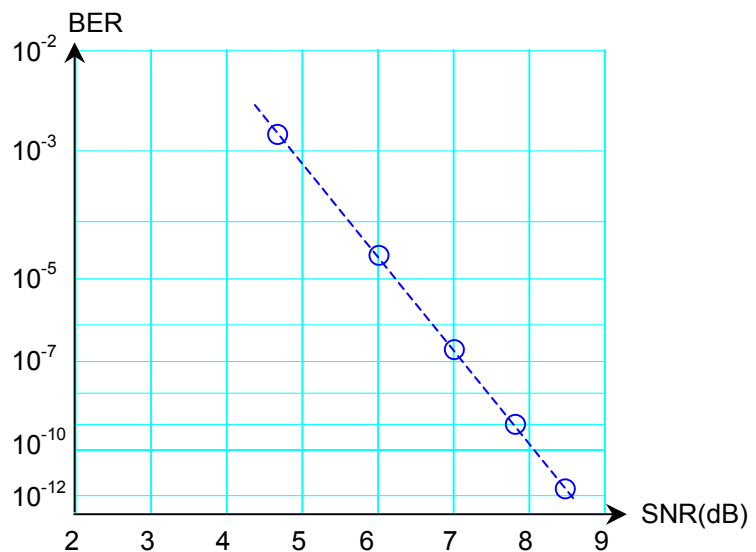

Figure 1.5-12 Relationship between SNR and BER

Bit Rate

The Bit Rate is the speed at which the communications interface sends and receives data. It is expressed in its center per second as bit/s or bps.

Mask Margin

This is margin of the masked waveform at the eye pattern mask test. The margin in the amplitude direction is the ratio to the interval from the edge of the eye mask to the 1 Level or the 0 Level.

The margin in the time direction is the ratio to the time from the edge of the eye mask to the cross point.

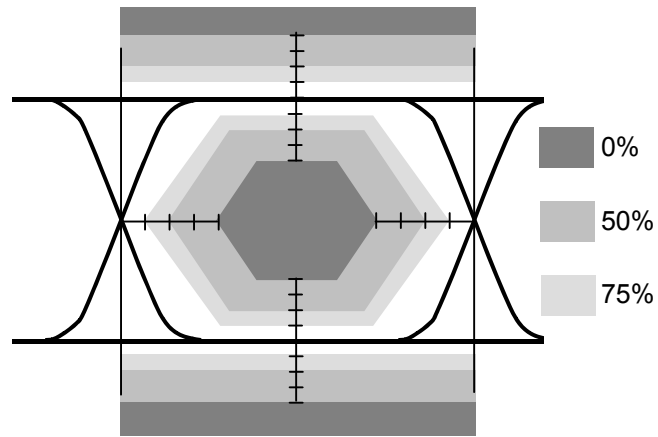

Figure 1.5-13 Mask Margin

1.6 Abbreviations

The abbreviations used in this manual are listed in Table 1.6-1.

Table 1.6-1 Abbreviation

Abbreviation	Formal Name
10 GbE	10 Giga bit Ethernet
App	Application
ATT	Attenuator
Avg	Average
BER	Bit Error Rate
BERT	Bit Error Rate Tester
BERTS	Bit Error Rate Test Set
BIN	Binary
bps	bit per second
BW	Band Width
Cal	Calibration
CC	Clock Count
CH	Channel
CLK	Clock
CPRI	Common Public Radio Interface
CRU	Clock Recovery Unit
DCD	Duty Cycle Distortion
DM	Degrade Minutes
DUT	Device Under Test
EC	Error Count
ED	Error Detector
EI	Error Interval
ER	Error Rate
ES	Error Seconds
ESD	Electrostatic Discharge
Ext	External
FC	Fiber Channel
FEC	Forward Error Correction
Freq.	Frequency
GbE	Giga bit Ethernet
GND	Ground
GPIB	General Purpose Interface Bus
IEC	International Electrotechnical Commission
IN	Input

Table 1.2.3-1 Abbreviation (Cont'd)

Abbreviation	Formal Name
INS	Insertion
INT	Internal
ITU	International Telecommunication Union
LAN	Local Area Network
LVDS	Low Voltage Differential Signaling
LVPECL	Low-Voltage Positive Emitter-Coupled Logic
NECL	Negative Emitter Coupled Logic
NEG	Negative
NRZ	Non Return Zero
OBSAI	Open Base Station Architecture Initiative
O/E	Optical to Electrical
OMI	Omission
OTU	Optical Transport Network
OUT	Output
PHY	Physical layer
PCML	Pseudo Current Mode Logic
POS	Positive
PPG	Pulse Pattern Generator
PRBS	Pseudorandom Bit Sequence
Pwr	Power
RMS	Root Mean Square
RP3	Reference Point 3
QSFP	Quad Small Form factor Pluggable
RX	Receiver
SCFL	Source-Coupled FET Logic
SES	Severely Error Second
SFP	Small Form factor Pluggable
SFP+	Enhanced small form factor pluggable module
SNR	Signal to Noise Ratio
SS	Sampling Scope
STM	Synchronous Transfer Mode
SYNC	Synchronize, Synchronization
Trig.	Trigger
TX	Transmitter
UI	Unit Interval
VECP	Vertical Eye Closure Penalty
WAN	Wide Area Network

Chapter 2 Before Use

This chapter explains the following items:

- Procedures from unpacking through turning power-on
- Panel name and operation
- Control panel and peripheral devices settings
- Damage prevention measures

2.1	Unpacking and Installation.....	2-2
2.1.1	Unpacking.....	2-2
2.1.2	Installation	2-2
2.2	Part Names	2-5
2.2.1	Front Panel	2-5
2.2.2	Rear Panel.....	2-8
2.2.3	Side Panel	2-9
2.3	Power Connection	2-10
2.3.1	Power Requirements	2-10
2.3.2	Connecting Power Cord	2-11
2.4	Connecting Peripheral Devices	2-12
2.5	Connecting Remote Control Devices	2-13
2.6	Cautions on Handling Optical Fiber Cables.....	2-14
2.7	Connecting Coaxial Cable	2-16
2.8	Installing Optical Transceiver.....	2-17
2.8.1	Installing Optical Transceiver	2-17
2.8.2	Removing Optical Transceiver	2-19
2.9	Turning Power On/Off.....	2-20
2.9.1	Power-on	2-20
2.9.2	Power-off	2-21
2.10	Using Touch Panel and Rotary Knob	2-23
2.11	Setting Control Panel.....	2-24
2.11.1	Displaying Windows Desktop	2-24
2.11.2	Setting Control Panel.....	2-25
2.12	Using External Monitor	2-26
2.13	Configuring Power Options.....	2-28
2.14	Setting Interface for Remote Control	2-29
2.14.1	To display setup window	2-29
2.14.2	To set GPIB	2-30
2.14.3	To set Ethernet.....	2-31
2.15	Precautions for Preventing Damage.....	2-34
2.15.1	Precautions on Electrostatic Discharge and Electrical Overstress	2-34
2.15.2	Precautions When Using Bias-T	2-38
2.16	System Recovery Function.....	2-40

2.1 Unpacking and Installation

2.1.1 Unpacking

At unpacking, check that all items are included. Contact an Anritsu Service and Sales office if any parts are missing or damaged. Keep the original packaging materials. They are required when transporting the BERTWave in future.

For how to repack the BERTWave, refer to 10.8, “Transporting and Disposal”.

The options listed in Table 1.2.2-1 are provided for the BERTWave. Verify that the options purchased are installed.

To install some options, the BERTWave might be returned to Anritsu factory. For the specifications, refer to Appendix A “Specifications”.

2.1.2 Installation

Install the BERTWave horizontally as shown in Figure 2.1.2-1

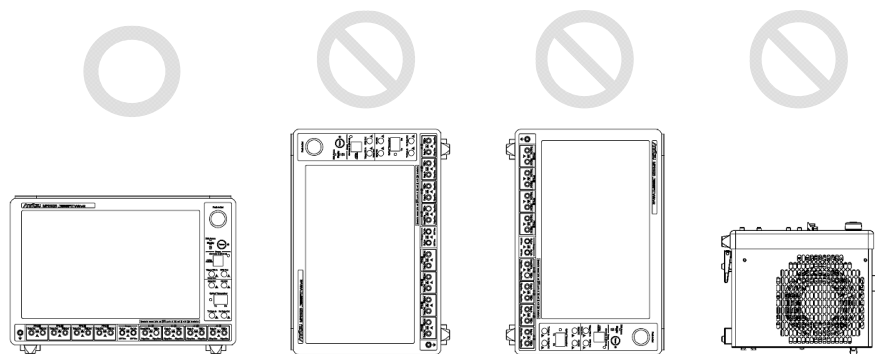

Figure 2.1.2-1 Installation Orientation

CAUTION

If the BERTWave series is not installed in a “good” direction as above, a small shock may turn it over and harm the user.

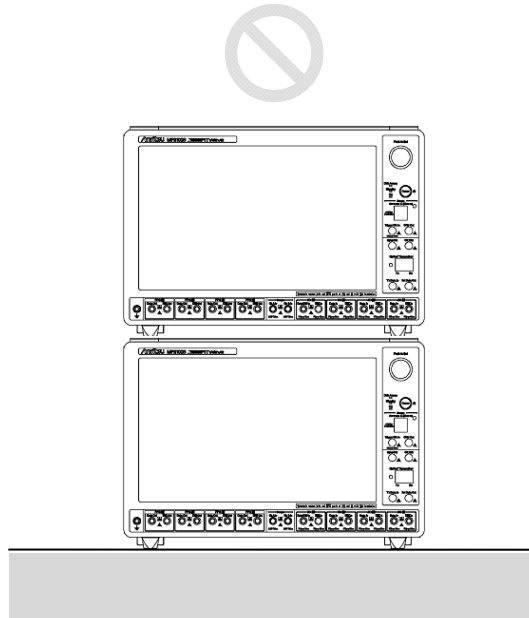

Figure 2.1.2-2 Prohibited Installation—Stacking

CAUTION

Do not stack multiple BERTWave units one on top of the other when using them. There is a risk of injury, because stacked units are unstable and can fall due to vibration or shock.

A fan is installed in the BERTWave to prevent the internal temperature from rising. Install the BERTWave in a location with the vents at least 10 cm away from walls, peripherals or other obstructions so as not to block the fan perimeter.

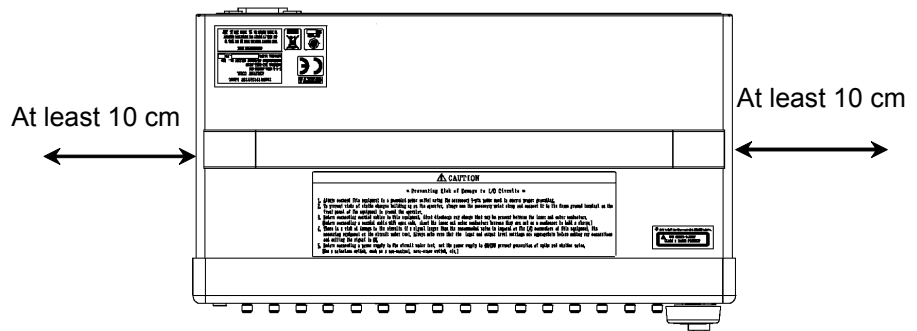

Figure 2.1.2-3 Distance from Surrounding Objects

The BERTWave takes in cooling air from the left side panel and exhausts it from the right side panel. When using two or more the BERTWave

units side-by-side, make sure that hot air exhausted from one unit is not taken into the adjacent unit, otherwise overheating may occur.

 **CAUTION**

Although the BERTWave operates at an ambient temperature of 5 to 40°C, avoid using it in locations, such as the following, since it may cause failure.

- In direct sunlight for extended periods
 - Outdoors
 - In excessively dusty locations
 - In liquids, such as water, oil, organic solvents, and medical fluids, or places where these liquids may adhere
 - In salty air or where chemically active gases (sulfur dioxide, hydrogen sulfide, chlorine, ammonia, nitrogen oxide, or hydrogen chloride etc.) are present
 - Where toppling over may occur
 - Where static electric charges or high electromagnetic fields are present
 - Where abnormal power voltages (high or low) occur
 - In the presence of lubricating oil mists
 - Where condensation occurs
 - In places at an altitude of more than 2,000 m
 - In the presence of frequent vibration and mechanical shock, such as in cars, ships, and airplanes
-

2.2 Part Names

2.2.1 Front Panel

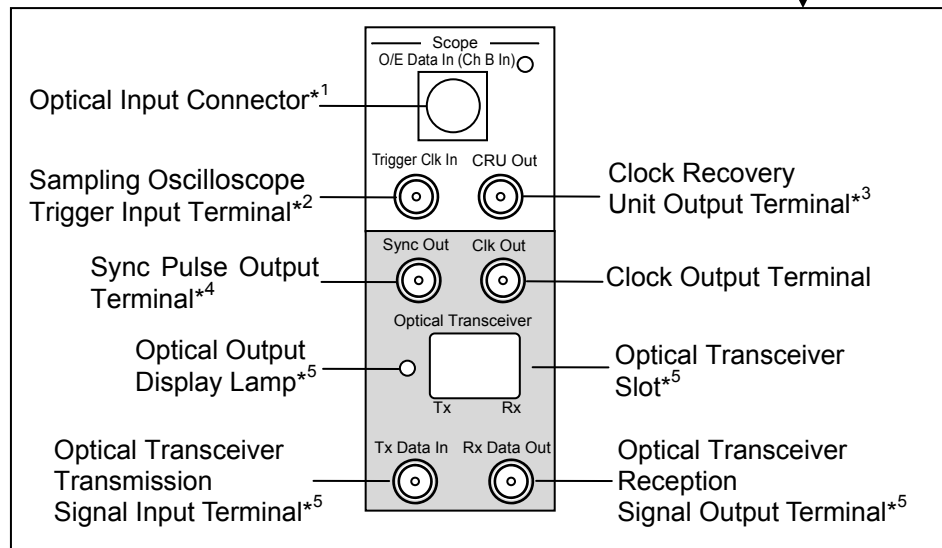
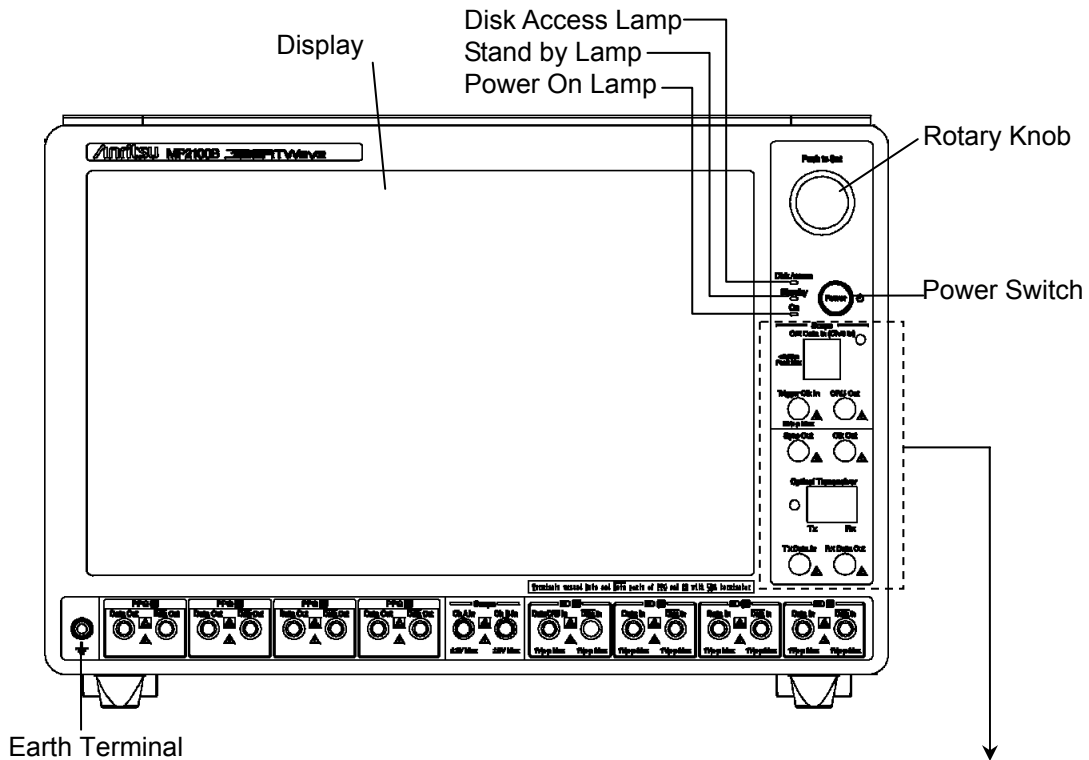

Figure 2.2.1-1 Front Panel 1

- *1: When the Option 023 is installed
- *2: When the Option 021 or 023 is installed
- *3: When the Option 053, 054, or 055 is installed
- *4: When the Option 011, 012, or 014 is installed
- *5: When the Option 051 is installed

2

Before Use

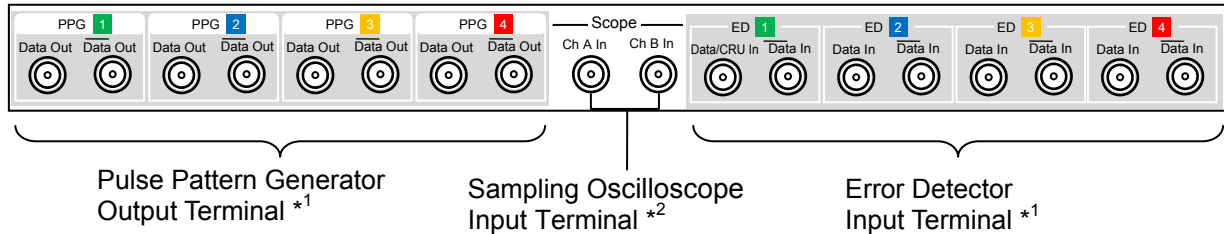

Figure 2.2.1-2 Front Panel 2

- *1: These connectors are available with the Option 014.
 Only PPG 1 and ED 1 are available with the Option 011.
 Only PPG 1, PPG 2, ED 1, and ED 2 are available with the Option 012.

- *2: Panel for the Option 021.
 Only Ch A In is available with the Option 023.

The following table describes the output terminals.

Table 2.2.1-1 Output Terminal List

Name	Description	Level Range
CRU Out	Outputs the clock generated by clock recovery.	270 to 540 mVp-p (2.7 GHz or less) 500 to 1500 mVp-p (8.5 to 12.5 GHz)
Sync Out	Outputs one of the following: <ul style="list-style-type: none"> • Divided clock synchronized with PPG output data • Pulse synchronized with PPG output pattern • Divided clock synchronized with data received by ED 	High: 0 V Low: -0.4 V
Clk Out	Outputs the clock synchronized with PPG output data.	300 to 750 mVp-p (Fixed)
Rx Data Out	Outputs signal data received by optical transceiver	-
Data Out*	Outputs PPG data.	100 to 800 mVp-p (Variable)
$\overline{\text{Data}} \text{ Out}^*$	Outputs inverted PPG data.	100 to 800 mVp-p (Variable)

*: Same for PPG1 to PPG4.

The following table describes the input terminals.

Table 2.2.1-2 Input Terminal List

Name	Description	Maximum Input Level
O/E Data In (Ch B In)	<u>When the Option 023 is installed</u> For signal input to channel B of the sampling oscilloscope <u>When the Option 054 is installed</u> This also serves as clock recovery input.	1.58 mW (+2 dBm)*1
Trigger Clk In	For trigger clock input to the sampling oscilloscope	2 V _{p-p}
Tx Data In	Optical transceiver transmission data input	–
Ch A In	For signal input to channel A of the sampling oscilloscope	±2 V
Ch B In	<u>When the Option 021 is installed</u> For signal input to channel B of the sampling oscilloscope	±2 V
Data/CRU In	ED data input with the Option 011, 012, or 014. <u>When the Option 055 is installed</u> This also serves as clock recovery input. <u>When the Option 053 is installed</u> For clock recovery signal input	1 V _{p-p}
Data In*2	For data input to ED	1 V _{p-p}
Data In*3	For inverted data input to ED	1 V _{p-p}

*1: Peak level

*2: Same for ED2 to ED4.

*3: Same for ED1 to ED4.

For details of the optical output level range and maximum optical input level for the optical transceiver, refer to A.2 “Optical Transceiver Module”.

2.2.2 Rear Panel

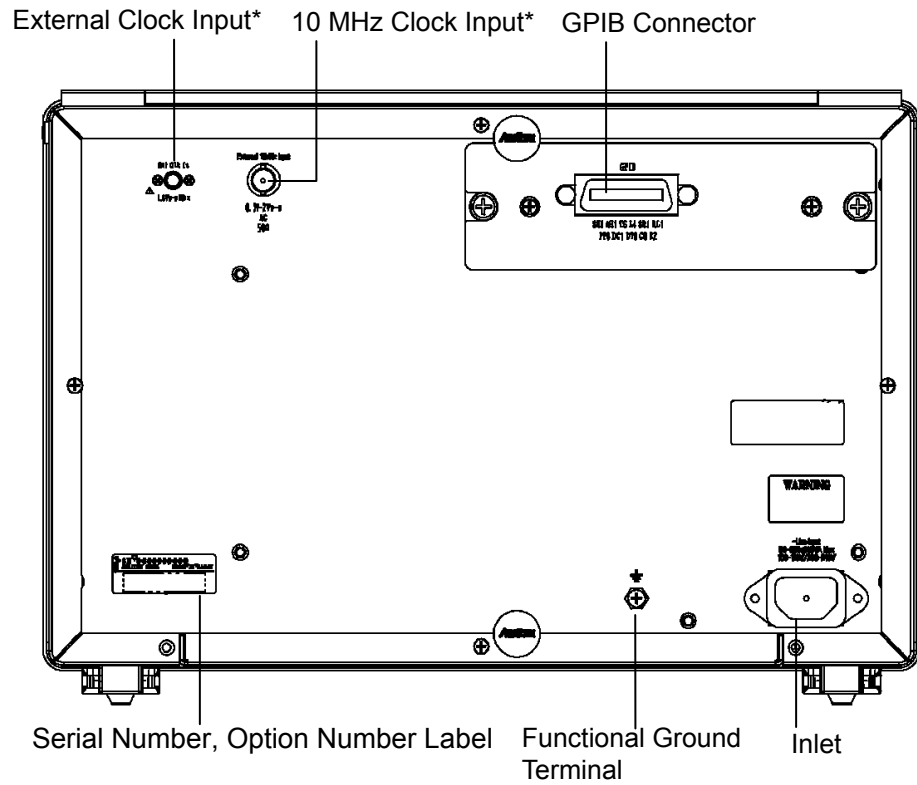

Figure 2.2.2-1 Rear Panel

*: When the Option 011, 012, or 014 is installed
 The following table describes the clock input terminals.

Table 2.2.2-1 Clock Input Terminal List

Name	Description	Input Range
Ext Clk In	For inputting the signal that sets the bit rate of PPG The bit rate will be 16 times the input signal frequency.	0.2 to 1.6 Vp-p Without the Option 092 531.25 to 707.5 MHz With the Option 092 390.625 to 781.25 MHz
External 10MHz Input	For inputting the frequency reference signal for PPG	0.7 to 2 Vp-p 10 MHz±100 ppm

2.2.3 Side Panel

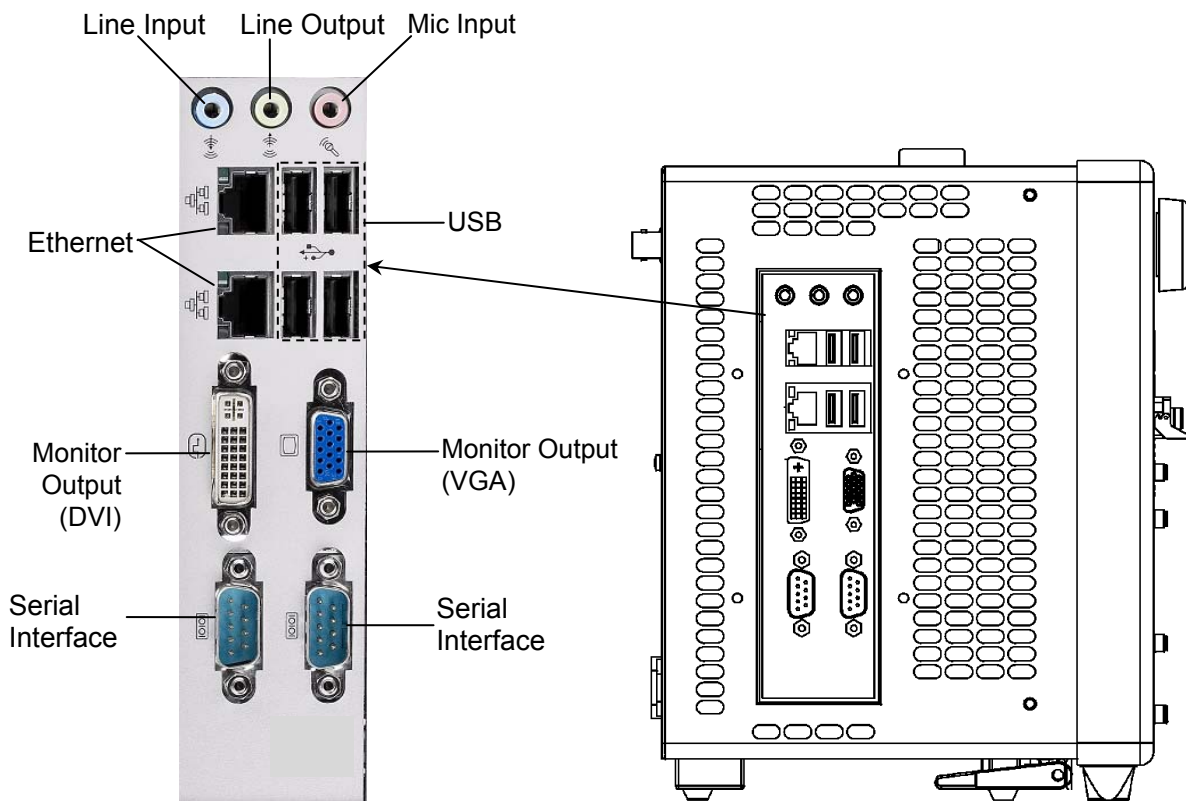

Figure 2.2.3-1 Left Side Panel

WARNING

Do not insert any metal object like, such as tweezers or a screwdriver, into vents on the side panels. Failure to do so can cause electric shock.

2.3 Power Connection

2.3.1 Power Requirements

For normal operation of the BERTWave, use the power voltage range described below.

Table 2.3.1-1 Power Requirements

Power source	Voltage range	Frequency
100 Vac system	100 to 120 V	50 to 60 Hz
200 Vac system	200 to 240 V	50 to 60 Hz

Switching between 100 and 200 V systems is automatic.

 **CAUTION**

Supplying power exceeding the above range may result in electrical shock, fire, failure, or malfunction.

2.3.2 Connecting Power Cord

Insert the power plug into an outlet, and connect the other end to the power inlet on the rear panel. To ensure that the BERTWave is grounded, always use the supplied 3-pin power cord, and insert the plug into an outlet with an earth terminal.

WARNING

Always connect the BERTWave to a properly grounded outlet. Do not use the instrument with an extension cord or transformer that does not have a ground wire.

If the BERTWave is connected to an ungrounded outlet, there is a risk of receiving a fatal electric shock. In addition, the peripheral devices connected to the BERTWave may be damaged.

Unless otherwise specified, the signal-connector ground terminal, like an external conductor of the coaxial connector, of the BERTWave is properly grounded when connecting the power cord to a grounded outlet. Connect the ground terminal of DUT to a ground having the same potential before connecting with the BERTWave. Failure to do so may result in an electric shock, fire, failure, or malfunction.

CAUTION

If an emergency arises causing the BERTWave to fail or malfunction, disconnect the BERTWave from the power supply by disconnecting either end of the power cord.

2.4 Connecting Peripheral Devices

USB devices

USB devices such as mouse, keyboard, storage, etc., can be connected to the left side panel USB connector.

No panel operations are required before removing USB devices from the BERTWave. USB devices can be removed at any time as long as no files are being written to or read from the USB device.

External Monitor

Connect an external monitor to the connector of the left-side panel monitor.

The supported monitor resolutions are 1280×800 dot or more. Available interfaces are RGB and DVI-D signal link.

Ethernet

Connect to the Ethernet connectors on the left side panel.

Either one of two connectors can be used, but each connector must have a different IP address.

To set the connector IP address, refer to Section 2.14 “Setting Interface for Remote Control”. However, when cables are connected to both connectors, remote control can be performed from one connector.

When using the Ethernet cable, select a category-5 or better crossover cable.

2.5 Connecting Remote Control Devices

Ethernet

Connects to the connector on the either up or down side of the two Ethernet connectors on the left side panel.

Use a category-5 or better crossover cable.

GPIB

GPIB can be used when the GPIB Option 030 is installed. Connect the cable to the rear-panel GPIB connector.

2.6 Cautions on Handling Optical Fiber Cables

Optical fiber cables may degrade in performance or be damaged if handled improperly.

Note the following points when handling them.

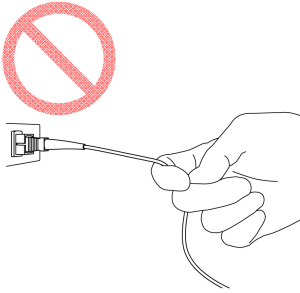

 **CAUTION**

Do not pull the cable when removing the connector.

Doing so may break the optical fiber inside the cable, or remove the cable sheath from the optical connector.

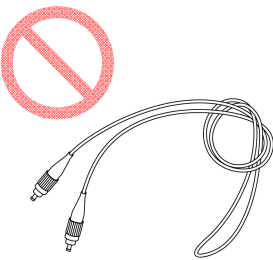

 **CAUTION**

Do not excessively bend, fold, or pinch an optical fiber cable.

Doing so may break the optical fiber inside the cable. Keep the bend radius of an optical fiber cable at 30 mm or more. If the radius is less, optical fiber cable loss will increase.

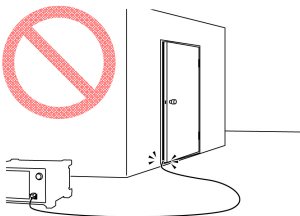
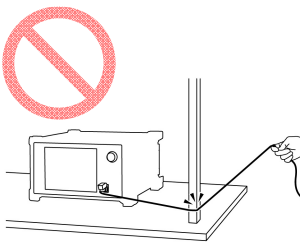



⚠ CAUTION

Do not excessively pull on or twist an optical fiber cable.

Also, do not hang anything by using a cable. Doing so may break the optical fiber inside the cable.

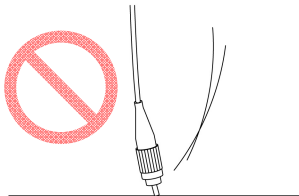

⚠ CAUTION

Be careful not to hit the end of an optical connector against anything hard such as the floor or a desk by dropping the optical fiber cable.

Doing so may damage the connector end and increase connection loss.

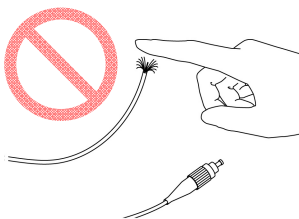

⚠ WARNING

Do not touch the end of a broken optical fiber cable.

The broken optical fiber may pierce the skin, causing injury.

⚠ CAUTION

Do not disassemble optical connectors.

Doing so may cause part to break or the performance to degrade.

2.7 Connecting Coaxial Cable

Connect the coaxial cable to the BERTWave coaxial connector.

Note the following precautions when handling coaxial cable.

WARNING

- Always use a coaxial cable with sufficiently low loss matching the signal to be measured. Correct measurement may be impossible if the cable loss is too large.
 - Use a coaxial cable with an impedance of 50 Ω . Correct measurement may be impossible if the impedance is incorrect.
-

CAUTION

- Use the correct coaxial cable for connecting to the coaxial connectors of the BERTWave, which are either SMA or K connectors. If the wrong coaxial cable for the connector is used, there is a risk of damage to the connector.
 - Tighten coaxial connectors to the correct torque. If the coaxial connector is over tightened, there is a risk of damage to the connector, which may prevent disconnection. If the connector is not sufficiently tightened, correct measurement may be impossible.
 - The outer conductor and inner core of a coaxial cable can sometimes become charged like a condenser. Discharge any possible charges by touching the outer conductor and inner cores to something metallic.
 - When operating the BERTWave with other equipment, arrange so that the co-axial cables are not accidentally pulled; if they are pulled accidentally, the BERTWave may be dragged off the bench top and damaged.
 - Keep the protective caps fitted to unused coaxial connector.
-

2.8 Installing Optical Transceiver

An optical transceiver can be used by adding the Option 051.

The optical transceiver can be installed or removed (hot-swap) while the BERTWave power is on.

2.8.1 Installing Optical Transceiver

1. Check that the optical transceiver specifications for wavelength and bit rate match the test conditions.
2. Hold both sides of the optical transceiver between thumb and forefinger.
3. Insert the optical transceiver into the slot on the front panel until it clicks.
4. Remove the protective cover from the optical transceiver.
5. Lift the lever to lock the optical transceiver.

2

Before Use



Figure 2.8.1-1 Installing Optical Transceiver

CAUTION

- When inserting the optical transceiver, set the optical transceiver lever to the up position. If the optical transceiver is inserted with the lever down, sometimes the transceiver may not be fully inserted.

 **CAUTION**

- Always fit the protective cover to the installed optical transceiver. If dust enters the optical connector, it may cause measurement problems.
 - Optical transceiver can be damaged by electrostatic discharge. To prevent risk of ESD, touch the frame ground connector on the front panel.
 - If the optical connector ferrule is dirty, clean it as described in section 10.3 “Cleaning Optical Connector Ferrule”.
 - Do not look directly into the optical connector when a fiber cable is not connected, because laser light from the optical transceiver may enter your eyes.
 - Before inserting and removing the optical transceiver always disconnect any connected optical fiber cable. If the transceiver is inserted while optical fiber is connected, there is a risk of damage to the optical connector of the optical transceiver or to the fiber.
 - Do not touch the optical connectors between the optical transceiver and the BERTWave. If they are touched there is a risk of damage to the optical transceiver.
 - Operation is not assured if an optical transceiver other than those recommended by Anritsu is used. Only use recommended modules. The list of recommended modules are available at our website:
<http://www.anritsu.com/>
 - The internal connector for optical transceivers has an insertion/removal life span of 100 times. If optical transceivers are inserted/removed more than 100 times, aging wear may cause connection failures. Make sure to observe this specification.
-

2.8.2 Removing Optical Transceiver

1. Set the optical output of the optical transceiver to OFF.
2. Turn off the signal input to the Tx Data In connector.
3. Disconnect the optical fiber from the optical transceiver.
4. Tilt the optical transceiver lever towards you.
5. Pull the optical transceiver out by the lever.



Note:

The optical transceiver cannot be detached without tilting the lever towards you.

2.9 Turning Power On/Off

2.9.1 Power-on

1. Connect the power cord plug, referring to Section 2.3 “Power Connection”.
The BERTWave enters the standby state and the power switch lamp lights orange.
2. Press the power switch.
The power lamp lights green and the Windows start-up begins.
3. In 30 seconds, the selector screen is displayed.

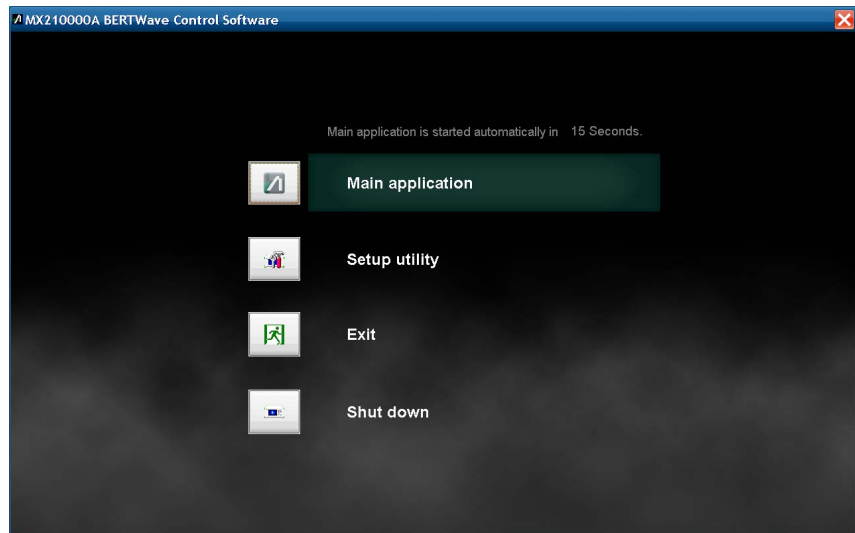

Figure 2.9.1-1 Selector Screen

Notes:

If no button on the selector screen is touched within 15 s, the [Main Application] is executed by default.

Do not press the power switch while the start-up screen is displayed, otherwise the BERTWave Control software may not start normally.

The Selector screen buttons execute the following processing:

[Main Application]: Displays the application screen where you can configure settings for the PPG, ED, sampling oscilloscope, and optical interface and view the measurement results.

For details on how to use the screen, refer to the following chapters:

- Chapter 4, Screen Operation
- Chapter 5, Generating Pulse Signal
- Chapter 6, Measuring Bit Error
- Chapter 7, Observing Waveform
- Chapter 8, Operating Optical Interface

[Setup Utility]: Displays the setup window where you can configure the remote interface, view the configuration and version of the software and update the software.

[Exit]: Displays Windows Explorer where you can work with files saved by the Main Application.

[Shut down]: Shuts down the power.

2.9.2 Power-off

Turning off the power in the Selector screen

1. Touch [System Menu] in the application screen.
2. Touch [Exit].
3. Touch [Yes], and the selector screen appears.
4. Touch [Shut Down] at the Selector screen.
5. In the Confirm Shutdown dialog box, touch the [OK] button to quit Windows.

The green Power switch lamp goes off, the standby lamp lights orange, and the power is turned off.

Turning off the power by shutting down Windows

1. Touch [Main Application] at the Selector screen.
2. The measurement screen is displayed, and then touch [System Menu] on the upper-right of the screen.
3. Touch [Minimize].
4. Touch [Start] menu of the Windows task bar.
5. Touch [Shut Down].
6. Confirm that [Shut Down] is displayed and touch [OK].
7. The green Power switch lamp goes off, the sand by lamp lights orange, and the power is turned off.

Forced shutdown

Press the Power switch for 4 seconds or more.

The green Power switch lamp goes off, the stand by lamp lights orange, and the power is turned off.

Notes:

- Only use forced shutdown as an emergency operation when key, mouse, and keyboard operations fail. A fault may have occurred if the power cannot be turned off even by pressing the Power switch for 4 or more seconds. Unplug the power cord from the power outlet and contact your Anritsu Service and Sales Office or agent.
- If the power plug is removed while the panel access lamp is lit, the data may not be saved correctly. Depending on the type of data that was not saved correctly, sometimes the equipment may not start correctly at the next power-on. Remove the power plug after cutting the power.
- The power may not turn on correctly if the power is turned off and then turned on again immediately after the Stand by lamp illuminates orange.
Wait at least 5 seconds after turning off the power before turning on again.

2.10 Using Touch Panel and Rotary Knob

The BERTWave can be operated using the touch panel and rotary knob.

Touch Panel Operation

- The touch panel has the same hardness as a 3H lead pencil. Touching the screen with anything sharp or hard will damage it.
- Touch the required spot on the touch panel once. If two spots are touched simultaneously, the intermediate point will be detected.

In this manual, touching the touch panel with a finger is called “touch”.

Rotary Knob Operation

- Pressing the Rotary Knob performs the same operation as pressing the Enter key.
- Don't pull or hit the Rotary Knob, otherwise it may be damaged.

2.11 Setting Control Panel

The BERTWave is set to the factory defaults for optimal measurement. Changing the Windows settings is outside the scope of operation warranty. In addition, the performance may drop or functions may not operate correctly if the Windows settings are changed. Read the general notes in this section carefully when changes to the Windows settings are required.

 **CAUTION**

Anritsu guarantees the BERTWave to work properly only when the factory settings for Windows have not been changed.

BERTWave operations are not guaranteed if program installation or update, including Windows Update, is performed.

Changing registries may cause abnormal operations.

2.11.1 Displaying Windows Desktop

Connect a mouse and a keyboard to operate Windows. Use the accessory USB mouse and a compatible USB keyboard.

The Windows desktop can be displayed as described below.

To display the BERTWave application again, touch [MX210000A] on the Windows taskbar.

When using touch panel and mouse:

1. Touch [Main Application] at the Selector screen.
2. The measurement screen is displayed. Touch [System Menu] on the left upper side of the screen.
3. Touch [Minimize].





When using keyboard:

Press the Windows + [D]. All windows will be minimized to display the Windows desktop.

2.11.2 Setting Control Panel

The system time, external display settings and touch panel settings are set at the Windows Control Panel. Do not change any settings other than those listed in Table 2.11.2-1.

Table 2.11.2-1 Description of Control Panel

Icon	Description
	<p><u>Date and Time</u></p> <ul style="list-style-type: none"> • Change the date, time and time zone as necessary. • Internet Time is set to off at factory shipment. Operation may be affected if this setting is changed.
	<p><u>Display</u> <u>Intel® GMA Driver for Mobile</u></p> <ul style="list-style-type: none"> • This setting must be changed when connecting an external monitor to the VGA connector. For details, refer to Section 2.12 “Using External Monitor” for details. • Changing the screen resolution, refresh rate or power management, or enabling the screen saver may cause abnormal BERTWave operation. Figure 2.11.2-1 shows the initial Display Settings.
	<p><u>Power Options</u></p> <ul style="list-style-type: none"> • The setting of the auto monitor off function (Turn off monitor) can be changed. • The setting of the power off function for hard disks (Turn off hard disks) is set to Never by default. Do not change the setting. • For any other settings in the Power Options Properties dialog box, do not change from default. Otherwise, the BERTWave cannot operate normally after resuming from hibernation.
	<p><u>Touch Panel</u></p> <ul style="list-style-type: none"> • This calibrates the touch panel detection point. For details refer to Section 10.6 “Touch Panel Position Calibration”.

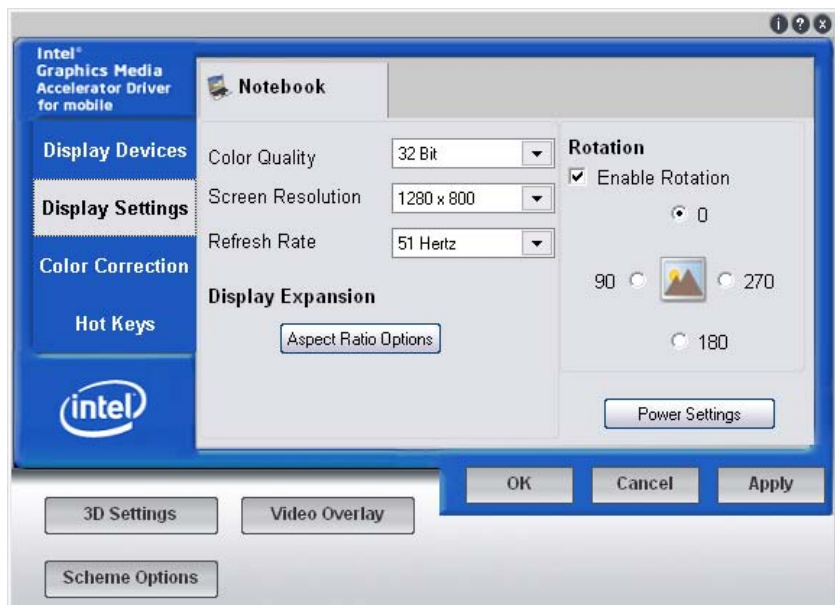

Figure 2.11.2-1 Initial Display Settings

2.12 Using External Monitor

When using a DVI connector

You don't need to make any settings when using a DVI connector to connect the BERTWave to an external monitor. When the external monitor is connected with the DVI connector, the BERTWave screen will be displayed on the external monitor.

When using a VGA connector

This section explains how to display the BERTWave screen on the external monitor.

1. Connect the external monitor to the monitor connector on the left side panel of the BERTWave.
2. Set the BERTWave and monitor power to On.
3. Touch [Main Application] at the Selector screen.
4. Touch [System Menu].
5. Touch [Minimize].
6. Touch [Start] on the right bottom of the screen.
7. Touch [Control Panel].
8. Touch [Intel(R) GMA Driver for Module] twice to display the following monitor setting screen.

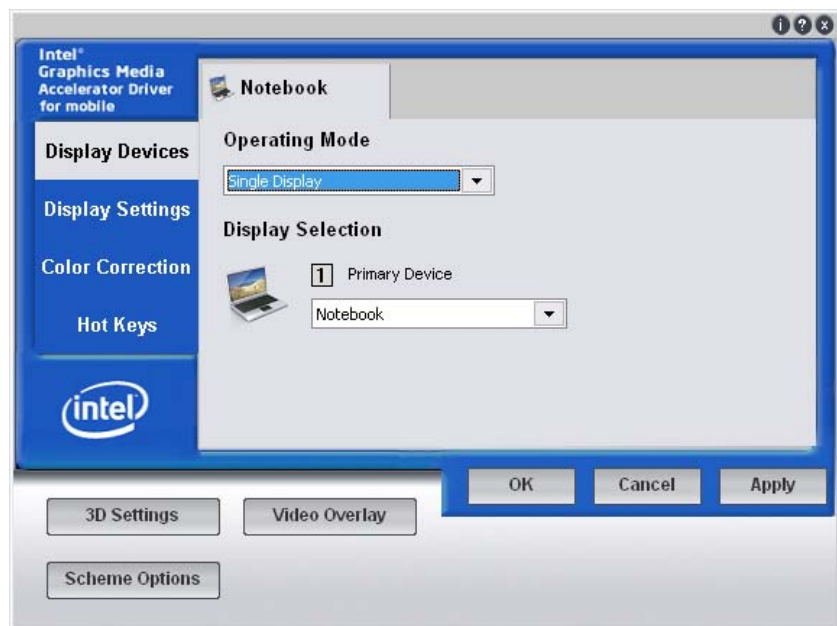

9. Touch [Operating Mode], and then touch [Intel(R) Dual Display Clone].
10. Touch [Display Setting].
11. Touch [Monitor].



2

Before Use

12. Touch the button if [Aspect Ratio Options] is enabled. A new window opens. If [Aspect Ratio Options] is not available, proceed to step 15.
13. Touch [Maintain Aspect Ratio].
14. Touch [OK] to close the separate window.
15. Touch [OK].
16. When you are asked if you really want to save the new display settings, touch [OK].

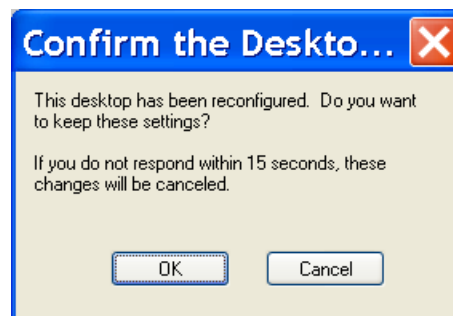

17. Touch [MX210000A] on the task bar.

When the monitor is disconnected from the monitor output connector, the screen shown in step 8 returns to [Single Display].

2.13 Configuring Power Options

You can increase the life of the monitor by using the standby feature in Windows. Follow the procedure described below to set to turn off the monitor after a specified period of time.

1. Touch [Start] on the right bottom of the screen.
2. Touch [Control Panel].
3. Touch [Power Option] twice.

The Power Options Properties dialog box appears as shown below.

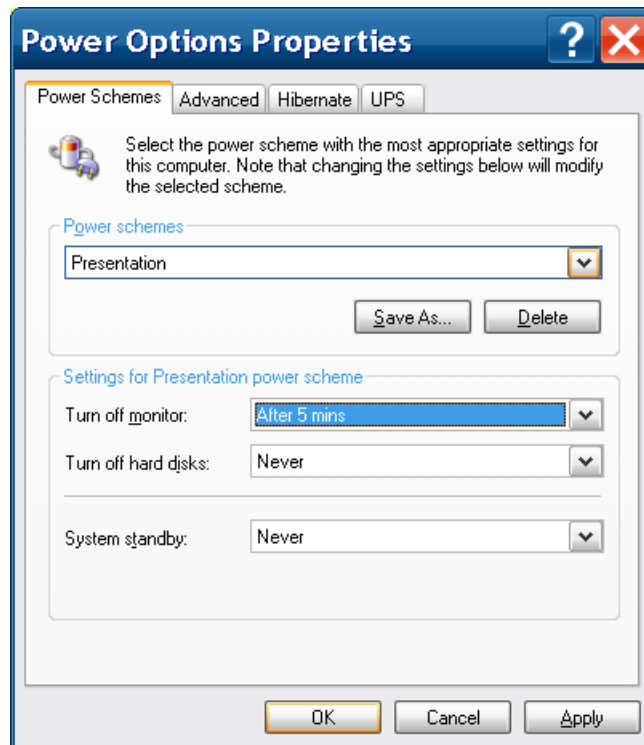

4. In the [Turn off monitor] list, touch a period of time you want to turn off the monitor after the specified period time.
5. Touch [OK].

CAUTION

In the Power Options Properties dialog box, select “Never” from both of [Turn off hard disks] and [System standby] lists.

Failure to do so may interrupt measurement or cause malfunction when the BERTWave enters into a standby state.

2.14 Setting Interface for Remote Control

This section describes how to set the type and address of the interface used for remote control of the BERTWave.

2.14.1 To display setup window

1. Touch [Setup Utility] in the selector screen.

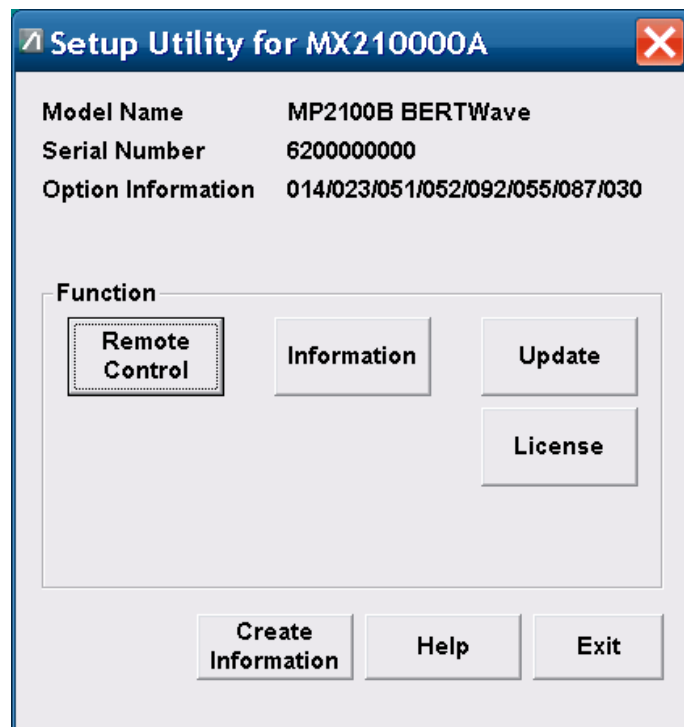

2. Touch [Remote Control].
The window to set the remote interface is displayed.

2.14.2 To set GPIB

1. In the **Active Interface** area of the Remote Control window, touch the button to change the button name to **GPIB**.
If the Option 030 is not installed, GPIB is not displayed.

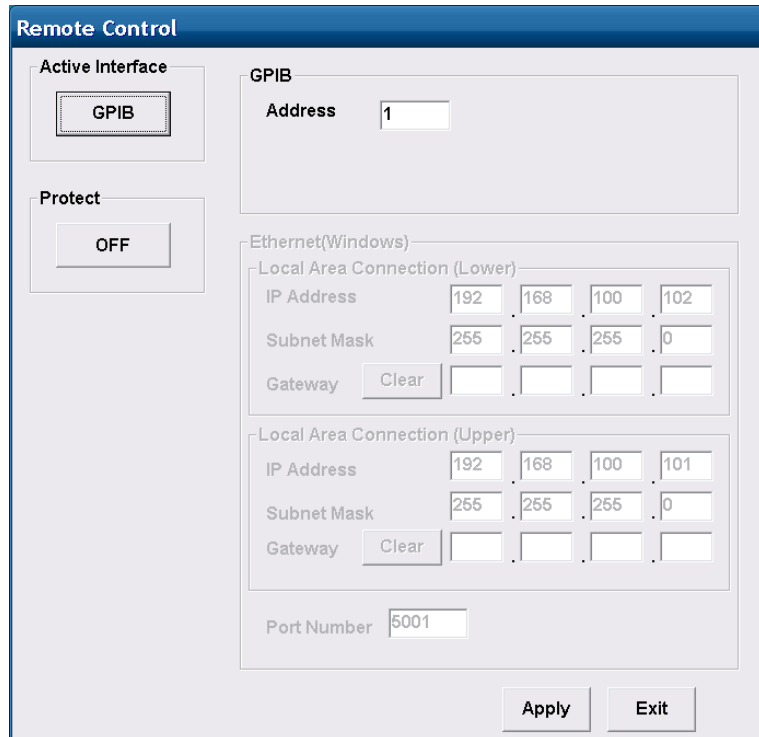

2. Touch the GPIB Address text box. A dialog box for inputting the address is displayed.
3. Enter the GPIB address from 1 to 30.
4. Touching the [Apply] button completes the settings.
Touching the [Exit] button deletes the settings made at steps 3 and 4.
5. Touching the [Protect] button protects the GPIB address value from being edited easily. Use this button as required.

2.14.3 To set Ethernet

1. In the **Active Interface** area of the Remote Control window, touch the button to change the button name to **Ethernet**.

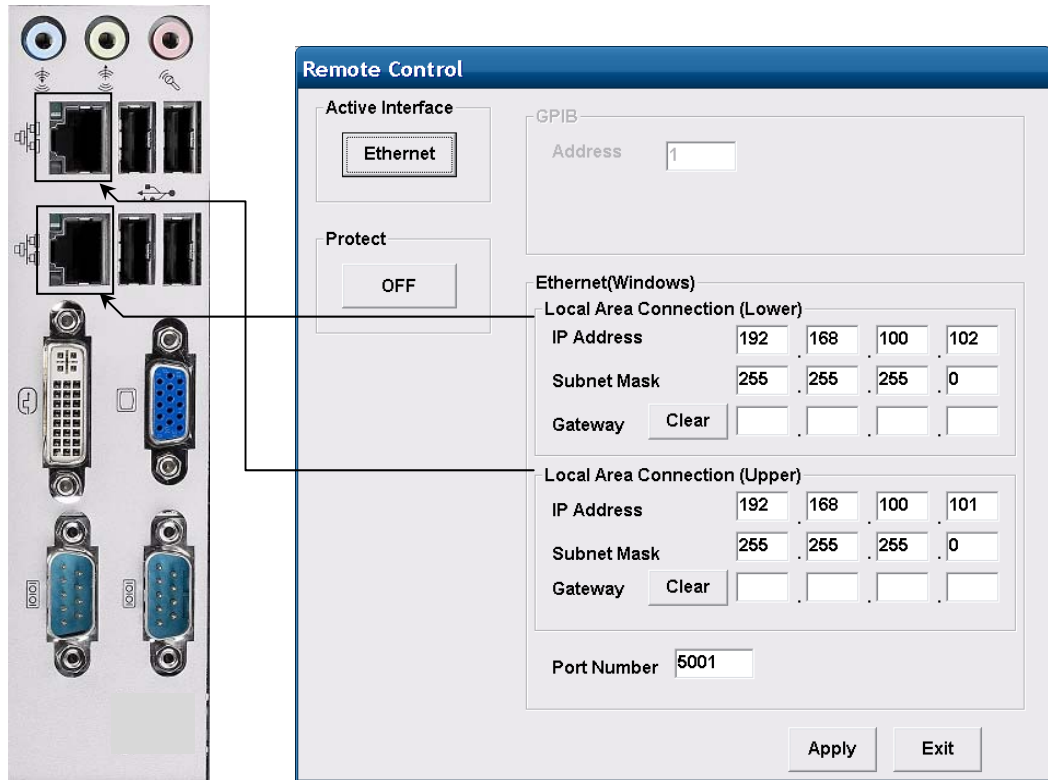

2. Set the IP address, Subnet Mask and Gateway for the Ethernet connector.
Touch the text box to open the address input window.
The Gateway IP address can be omitted.
3. Touch the Port Number text box to open the port input window.
4. Set the number in the following range:
Port Number: 1024 to 5001
5. Touch the [Apply] button to complete the settings.
Touching [Exit] deletes the settings.
6. Touching the [Protect] button protects the IP address and other values from being edited easily. Use this button as required.

Notes:

- Do not set the following IP addresses for Local Area Connection: 192.168.1.0 to 192.168.1.255
The BERTWave may not work correctly if IP addresses within this range are set.
- To automatically acquire the IP address of Local Area Connection, using DHCP, set via the Windows [Control Panel] -

[Network Connections].

- Do not change the Windows [Control Panel] - [Network Connections] Internal Connection setting. Otherwise, the BERTWave may not work correctly.

If the IP address has been changed, restore the settings to the following values.

IP address: 192.168.1.1
Subnet mask: 255.255.255.0

To automatically acquire the Local Area Connection IP address, using DHCP, set via the Windows [Control Panel]. In this case, [Setup Utility] will appear as Local Area Connection (DHCP).

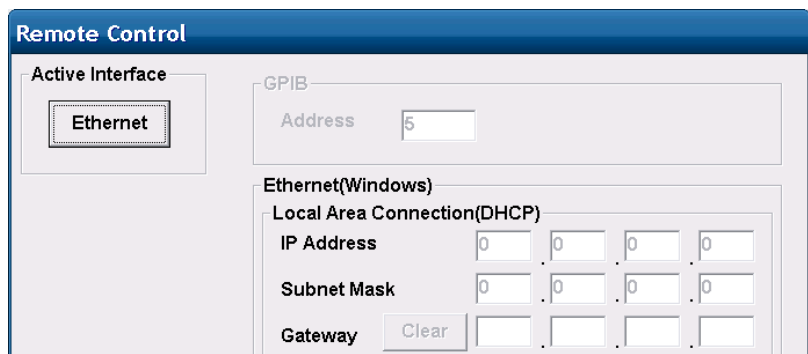

The procedure for changing the setting via the Windows [Control Panel] is as follows.

1. Connect a keyboard and mouse to the BERTWave.
2. Press the Windows key on the keyboard.
If there is no Windows key on the keyboard, press [Ctrl] + [Esc].
3. Click [Control Panel].
4. Double-click [Network Connections].

- Right-click [Local Area Connection (Upper)] or [Local Area Connection (Lower)], and then click [Properties].

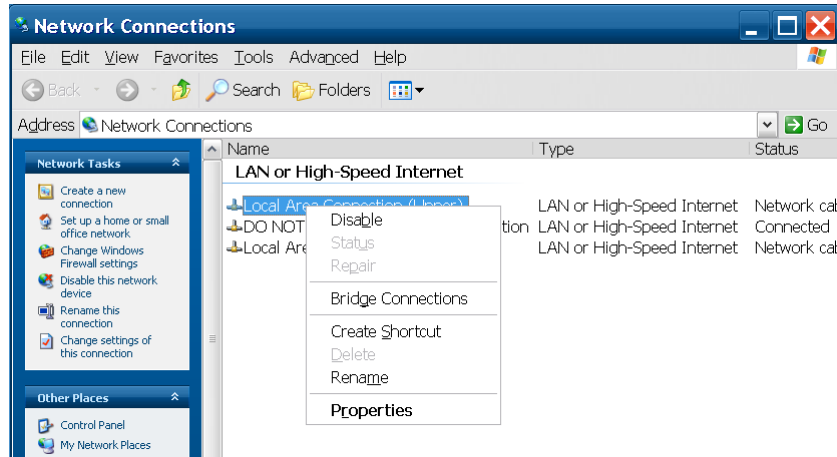

2

Before Use

- The Local Area Connection Properties dialog box opens. Click [Internet Protocol (TCP/IP)] in the list box, and click the [Properties] button.

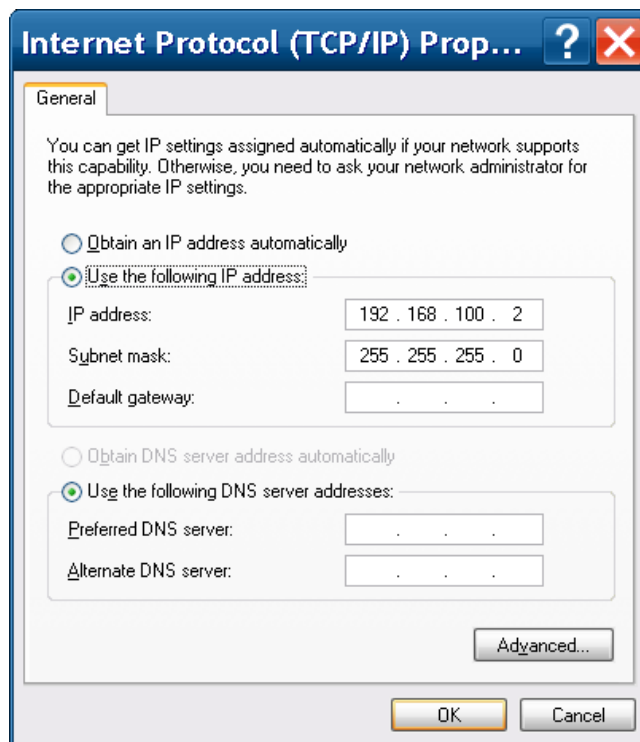

- Click [Use the following IP Address] or [Obtain an IP address automatically].
- Click the [OK] button.
- Click the [OK] button for [Local Area Connection Properties].

2.15 Precautions for Preventing Damage

Before connecting signals to the input and output connectors of the BERTWave, always check that the signals are within the specified voltage range.

If an out-of-range signal is input, the BERTWave may be damaged.

 **CAUTION**

- Use a 50 Ω /GND terminator for the device to be connected to the output connector.
 - Never open the case of the BERTWave.
If you open it and BERTWave has failed or sufficient performance cannot be obtained, Anritsu may not accept a request for repair.
-

2.15.1 Precautions on Electrostatic Discharge and Electrical Overstress

 **CAUTION**

- When signals are input to the BERTWave, avoid excessive voltage beyond the rating. Otherwise, the circuit may be damaged.
 - Never feed any current or input signals to the output connector.
 - As a countermeasure against static electricity, connect the ground structures (for example, frame ground) of external devices, including experimental circuits, to the ground terminal of the BERTWave by using ground wires before connecting the IO connector.
Shorten ground wires as much as possible.
 - To the input terminal of the BERTWave, connect an attenuator that can protect the BERTWave without affecting measurement results. An attenuator with a bandwidth of 25 GHz or more is recommended.
-

 **CAUTION**

- The outer conductor and core of the coaxial cable may become charged as a capacitor. Use any metal to discharge the outer conductor and core before use.
 - The BERTWave has many important circuits and parts including hybrid ICs. These parts are extremely sensitive to static electric charges, so never open the case of the BERTWave.
 - To prevent the risk of damage to the BERTWave from static electric charges, always use an antistatic mat on the workbench and ensure that the operator wears a grounded wrist strap. Always ground the wrist strap to the workbench antistatic mat or the frame ground of the BERTWave.
 - Always use 3-pin power cords when connecting external devices, including experimental circuits, to AC outlets. Connect the ground wires of external devices and BERTWave to a common ground.
 - Turn on the external devices, including experimental circuits, before connecting them to the BERTWave. Use coaxial cables when connecting. On the contrary, disconnect the coaxial cables between external devices and the BERTWave before turning off the external devices.
-

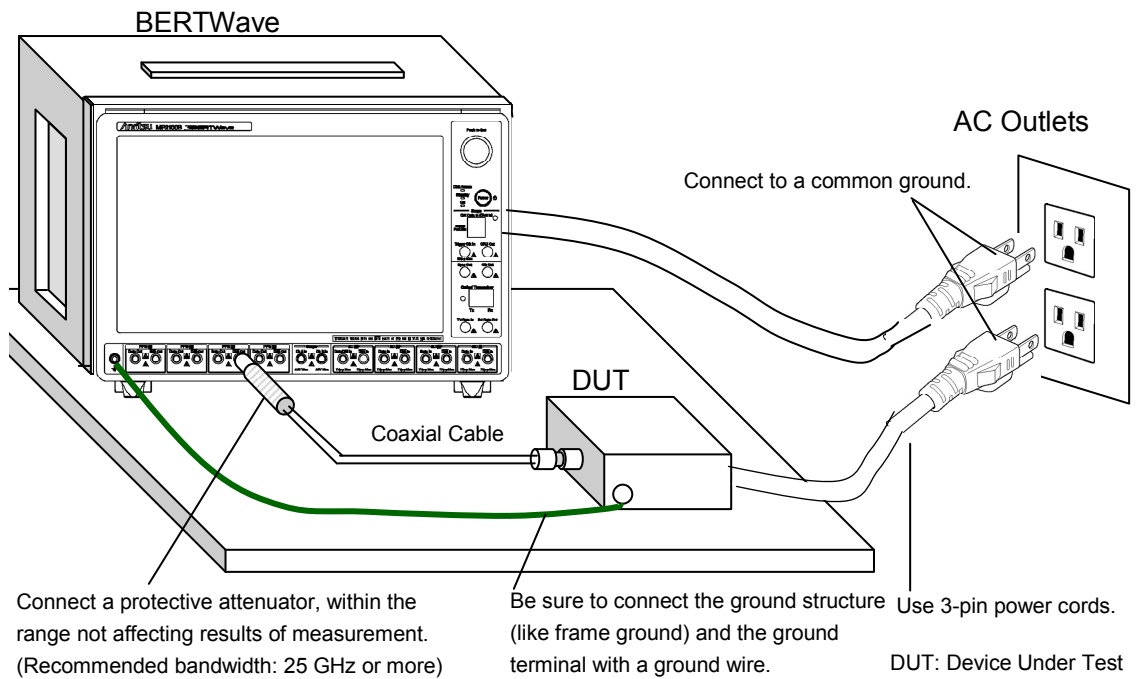

Figure 2.15.1-1 Example of Connection with DUT

Follow the procedure below to check for electrical overstress to the BERTWave before connecting DUT (Device Under Test).

Checking the ground connection using a tester

1. Connect DUT and the ground terminal of the BERTWave with a ground wire.
2. Turn on the power to DUT and BERTWave without connecting DUT to the I/O terminal of BERTWave.
3. Measure the voltage between DUT's ground structure and ground terminal of BERTWave with a tester in AC mode, and confirm the voltage is 0 V.

If the voltage measured in step 3 is not 0 V, there is a possibility that BERTWave and DUT may not be connected to a common ground. In this condition, do not connect the I/O terminal of BERTWave and DUT. Failure to do so may cause damage to BERTWave due to a voltage exceeding a rated value.

Review the ground wiring by, for example, changing the location of the DUT's ground wire connected to BERTWave so that the voltage measured in step 3 to be 0 V.

Notes:

If it is impossible to connect a ground wire to DUT, follow the instructions below so that the voltage to be measured in step 3 becomes 0 V.

- Check that the 3-pin power cords described in 2.3.2 “Connecting Power Cord” are used for the BERTWave and DUT.

When the 3-pin power cords are used, take the following actions:

- There may be a disconnection in the ground terminal of the used power cord. Replace it with a different 3-pin power cord.
- There is a possibility that the ground terminal inside the AC outlets to which the 3-pin power cords of BERTWave and DUT are connected is not connected to ground. Connect the 3-pin power cords to different AC outlets.

Checking the output waveform with an oscilloscope

1. Connect the DUT and the oscilloscope using a cable with an impedance of 50 Ω.
2. Set the input impedance of the oscilloscope to 50 Ω.
3. Observe the waveform with the oscilloscope, and perform the following operations to check the observed waveform for surge voltage exceeding the rated voltage*.

There is a risk of damage if a voltage exceeding the rated voltage* is generated.

- Turning On/Off the DUT power
- Outputting a pulse from DUT
- Connecting and disconnecting the cable between DUT and the BERTWave

*: The rated voltage is 1 Vp-p for ED and ±2 V for the scope.

2.15.2 Precautions When Using Bias-T

When connecting an external device such as a Bias-T to the output connectors of the BERTWave, if the output signal includes any DC voltage, variations in the output of the DC power supply or load may change the level of the output signal, risking damage to the internal circuits.

CAUTION

- Do not connect or disconnect any external devices while DC voltage is impressed.
- Only switch DC power sources ON and OFF when all equipment connections have been completed.

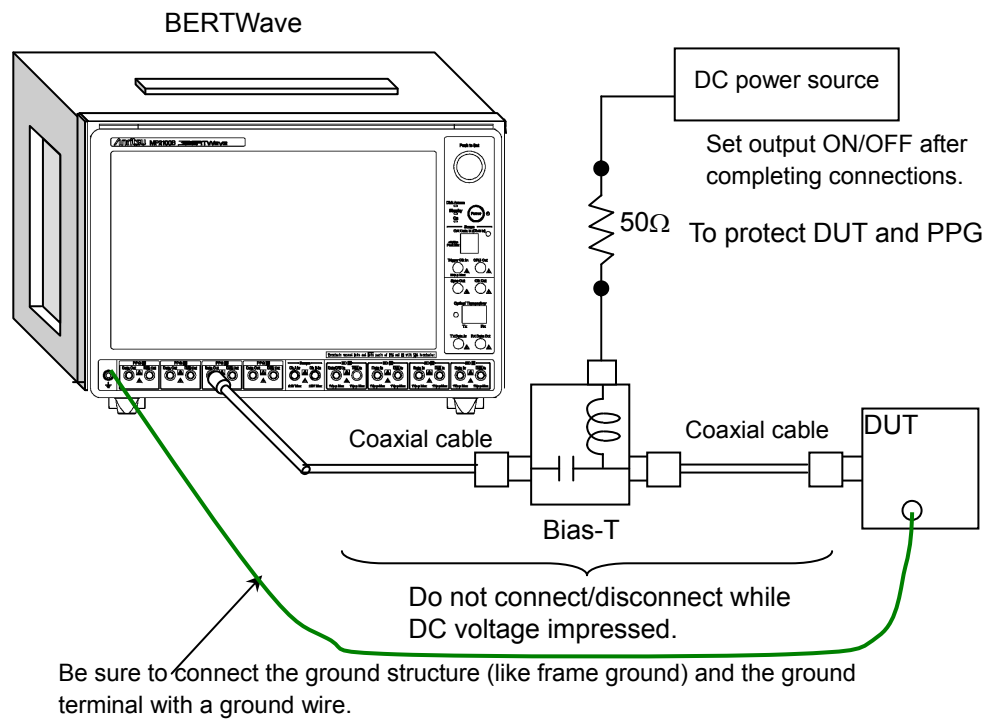

Figure 2.15.2-1 Bias-T Connection Example

<Recommended procedures>

Measurement Preparation 1:

1. Connect the BERTWave and all equipment.
2. Set the DC power supply output to ON.
3. Set the BERTWave output to ON, and start measurement.

Measurement Preparation 2:

1. Set the BERTWave output to OFF.
2. Set the DC power supply output to OFF.
3. Disconnect the BERTWave and all equipment, or change the DUT connections.

Since even unforeseen fluctuations in DC voltage and load (open or short circuits at the BERTWave output side and changes caused by using a high-frequency probe, etc.) can damage the DUT and the BERTWave, we recommend connecting a 50 Ω resistance in series with the DC terminal of the Bias-T to prevent risk of damage.

2.16 System Recovery Function

The BERTWave has system recovery function to restore data on the hard disk to the factory shipment status. These functions can be used in the event of system instability.



CAUTION

Fully understand the following and back up all necessary data before performing a system recovery.

- Executing system recovery restores the original Windows factory settings, and reverts the data stored on the C drive to the original factory state. All data such as applications and updates subsequently added, measurement conditions saved, measurement results, and screen captures will therefore be deleted.
 - Data deleted by these functions cannot be restored.
 - The backup data required for system recovery is stored in the Unknown Partition on Disk 0. System recovery cannot be performed if this Unknown Partition is deleted.
 - The MX210000A BERTWave Control Software must be re-installed if system recovery is performed. Before performing system recovery, prepare the MX210000A software installer for the version you are using.
-

<Procedure>

1. Disconnect the BERTWave from the network if connected.
2. Connect the keyboard and mouse to the mainframe, and then turn the BERTWave power On.
3. After the BIOS screen is displayed, press the F4 key on the keyboard when [Press F4 to start recovery from Backup Capsule] appears.
4. The recovery software [Drive Backup 11] menu screen appears. Use the keyboard cursor keys to select [Normal Mode], and then press [Enter].
5. The menu screen is displayed after approximately 2 minutes. Select and double-click [Simple Restore Wizard].
6. At the [Welcome to the Paragon Simple Restore Wizard] screen, click [Next].
7. At the [What to restore] screen, double-click and select the Disk image on the list, and then click [Next].
8. Click [Yes] on the [Warning] confirmation screen.

Note:

Clicking [Yes] displays the [Progress information] screen, and recovery starts. Do not click [Cancel] while recovery is in progress.

9. When recovery is complete, the button name changes from [Cancel] to [Close].Click [Close].
10. In the [Completing the Paragon Simple Restore Wizard] screen, click [Finish].The display returns to the menu screen in step 5.To restart the BERTWave, click [Reboot the computer]. To turn off the power, click [Power off].
11. The message “FBReseal - Resealing in progress...” appears when Windows is starting up immediately after performing system recovery. The Windows desktop will appear after approximately 10 minutes.
12. Install the MX210000A BERTWave Control Software in accordance with the release note.

Chapter 3 Connecting with DUT

The connection methods depend upon either optical or electrical DUT interface.

When changing the optical level input to the DUT such as the reception sensibility measurement, connect other measurement instruments such as optical attenuator.

This chapter explains how to connect the BERTWave and the DUT.

- 3.1 Measuring Bit Error Rate 3-2
- 3.2 Measuring Waveform..... 3-7
- 3.3 Simultaneously Measuring Bit Error Rate and Waveform
..... 3-12
- 3.4 Measuring QSFP Module Bit Error Rate 3-14

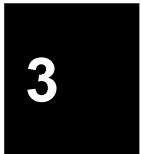

3.1 Measuring Bit Error Rate

When the DUT input/output signal is electrical:

1. Connect the DUT input terminal to PPG2 **Data Out** and **Data Out** connectors using the coaxial cable.
If the DUT has only one input connector, connect it to the **Data Output** connector of PPG2. Also, connect the coaxial terminator, which is attached to the BERTWave standard configuration, to the **Data Out** connector.
2. Connect the DUT output terminator to ED2 **Data In** and **Data In** connectors using the coaxial cable.
If the DUT has only one output connector, connect it to the **Data In** connector of ED2. Also, connect the coaxial terminator, which is attached to the BERTWave standard configuration, to the **Data In** connector.

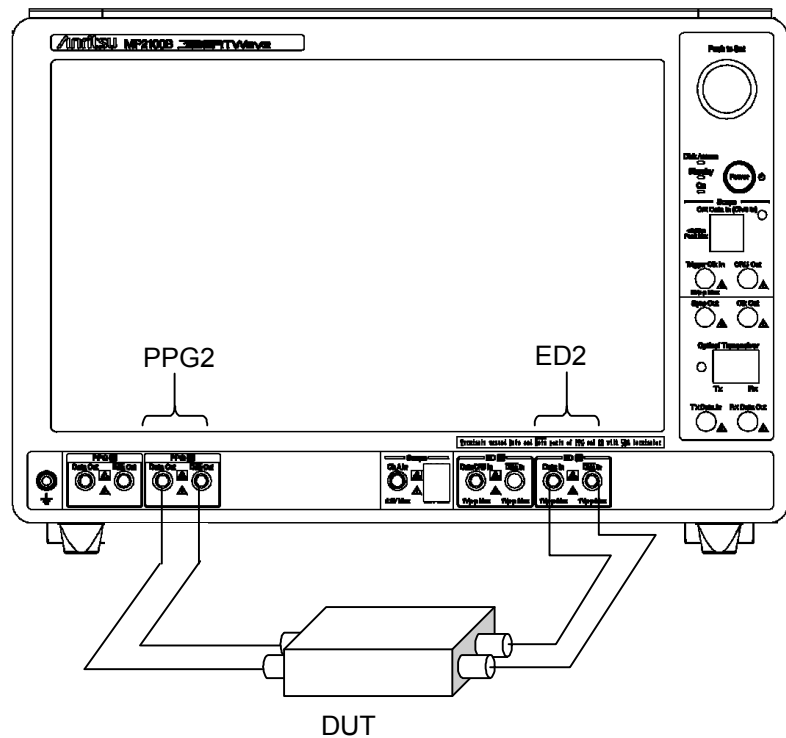

Figure 3.1-1 Making Connections Using Electrical Signal

When DUT is Optical Receiver:

Use the Option 051 and follow the connection procedures.

1. Connect the PPG2 Data Out and Tx Data In using a coaxial cable.
2. Connect the DUT input connector to the Optical transceiver using an optical fiber.
3. Connect the DUT output connector to ED2 Data In and $\overline{\text{Data}}$ In using a coaxial cable.

If only one DUT output connect is conveniently available, connect to ED2 Data In. Do not connect anything to $\overline{\text{Data}}$ In.

4. Connect the coaxial terminator provided with the BERTWave to ED2 $\overline{\text{Data}}$ In.

CAUTION

Check that the output power for the optical module inserted with the Option 051 is within the input level range for the DUT.

There is a risk of damaging the DUT if the optical power out of the input level range is applied.

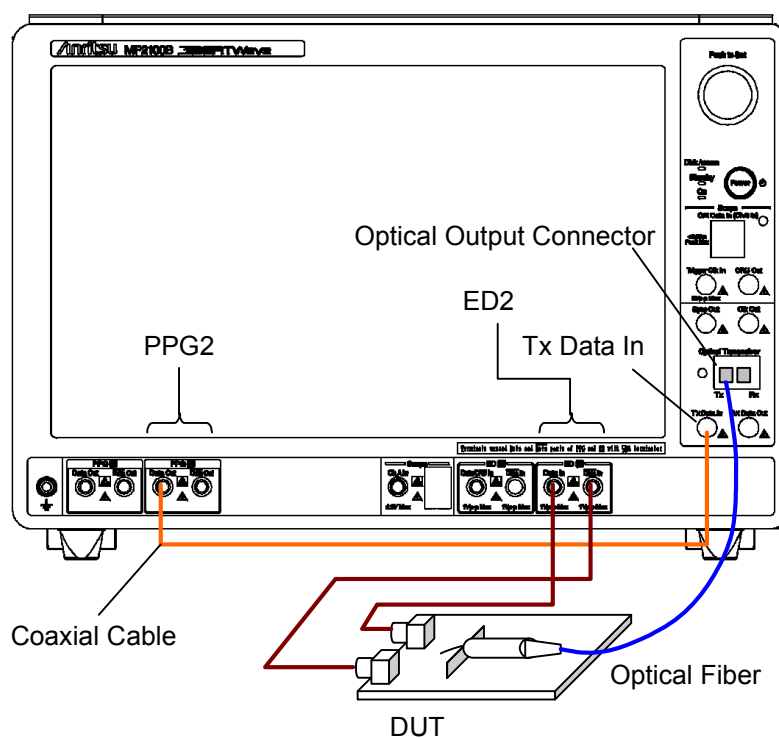

Figure 3.1-2 Connection when DUT is Optical Receiver

When the DUT changes the signal level using the optical receiver:

When measuring the sensibility of the optical receiver, connect to the optical attenuator to change the signal level input to the DUT.

Connect to the optical power meter to measure the optical level.

Use the optical coupler to bifurcate the optical signal into the optical power meter and DUT.

An optical switch can be used in place of the optical coupler.

1. Connect the PPG2 Data Out and Tx Data In using a coaxial cable.
2. Connect the coaxial terminator provided with the BERTWave to PPG2 $\overline{\text{Data}}$ Out.
3. Connect the DUT output connector and ED2 $\overline{\text{Data}}$ In/Data In using a coaxial cable.
4. Connect the optical output connector of the BERTWave optical transceiver to the input connector of the optical attenuator using an optical fiber.
5. Connect the output connector of the optical attenuator to the optical coupler.
6. Connect one end of the optical coupler to the input connector of the DUT.
7. Connect another end of the optical coupler to the optical power meter.

Connect as shown in the following figure.

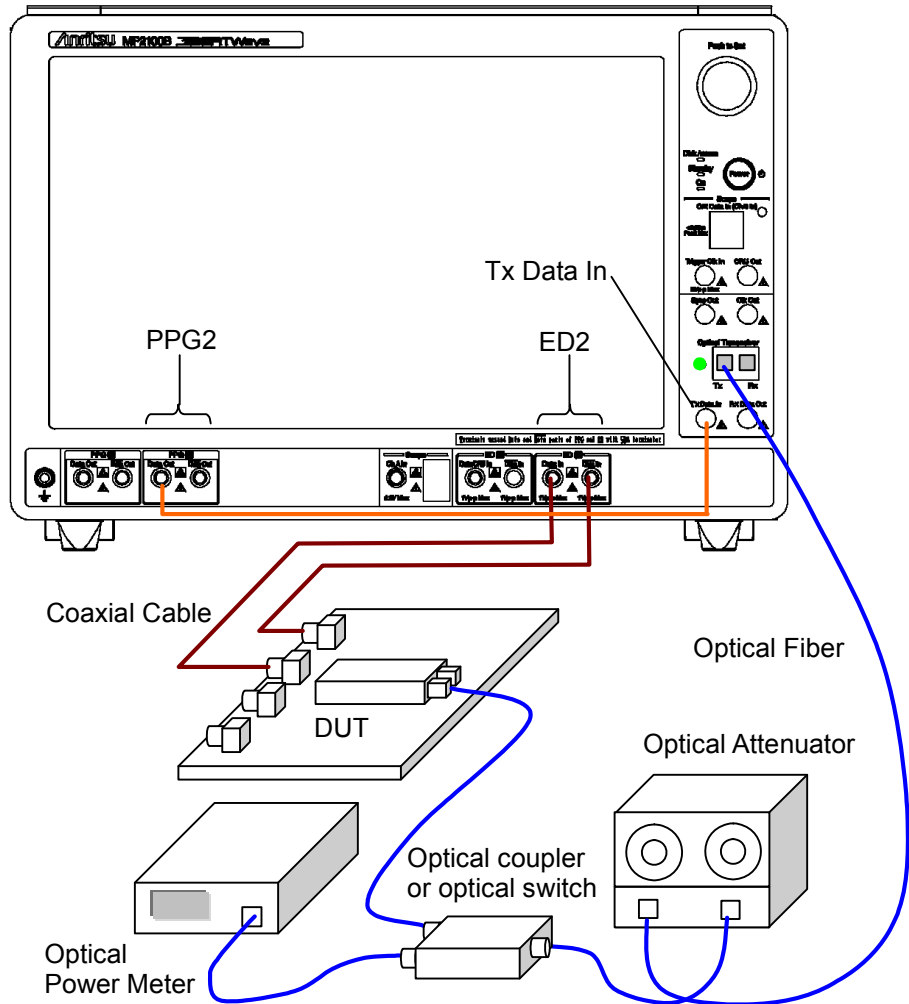

Figure 3.1-3 Connection for Changing Optical Level Input to Optical Receiver

When the DUT is an optical transmitter:

Use the Option 051 and follow the connection procedures.

1. Connect the PPG2 $\overline{\text{Data}}$ Out and Data Out to the DUT input terminal using a coaxial cable.
2. Connect the DUT output connector to optical transceiver for an optical input connector using an optical fiber.
3. Connect the Rx Data Out to ED2 Data In using a coaxial cable. Do not connect anything to $\overline{\text{Data}}$ In
4. Connect the coaxial terminator provided with the BERTWave to ED2 $\overline{\text{Data}}$ In.

CAUTION

Check that the DUT optical output level does not exceed the rated optical input level for the optical module inserted with the Option 051.

There is a risk of damaging the optical module if the optical power exceeding the rated optical input level is applied.

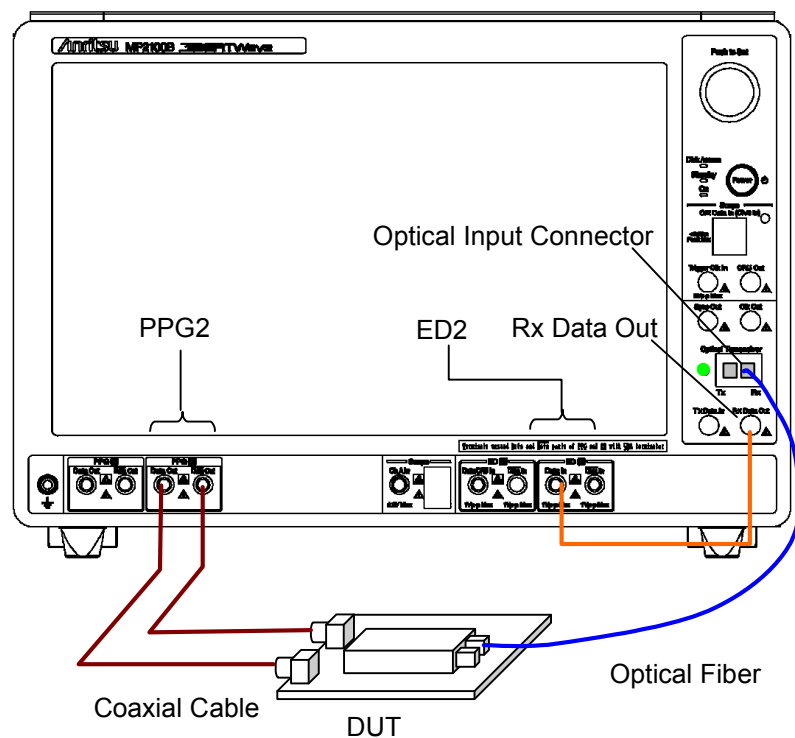

Figure 3.1-4 Connection when DUT is Optical Transmitter

3.2 Measuring Waveform

When the DUT input/output signal is electrical:

Input the output of the PPG in the BERTWave to the DUT, and then measure the DUT output using the sampling oscilloscope.

1. Connect the DUT input terminal to PPG1 $\overline{\text{Data Out}}$ /Data Out using a coaxial cable.
If only one DUT input connector is conveniently available, connect to the PPG1 Data Out. Also, connect the coaxial terminator included as a standard accessory to the $\overline{\text{Data}}$ Out.
2. With the Option 021, connect the DUT output terminator to A In and B In on the sampling oscilloscope using a coaxial cable.
If only one DUT output connector is conveniently available, connect to the A In. Also, connect the coaxial terminator included as a standard accessory to the B In.
3. Connect the Sync Out to Trigger Clk Input using a coaxial cable.

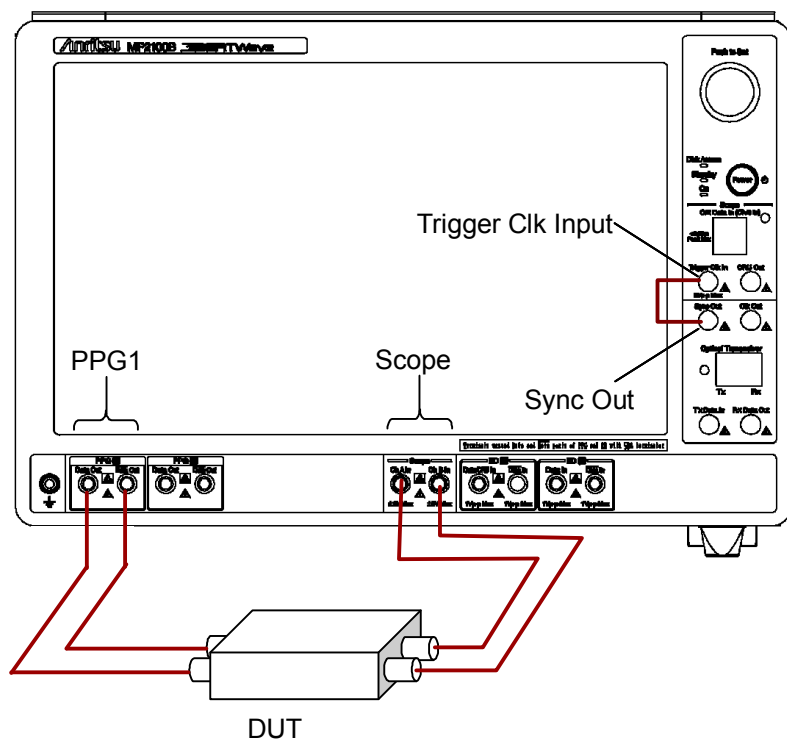

Figure 3.2-1 Electrical Signal Used for DUT Input/Output (Option 021)

When the DUT is an optical transceiver:

When the Option 023 is selected, the output waveform of the optical transceiver can be measured using the O/E converter.

Input the output of the PPG in the BERTWave to the DUT, and then connect the DUT optical output to the O/E Data In converter.

1. Connect the DUT input terminal to PPG1 $\overline{\text{Data}}$ Out/Data Out using a coaxial cable.
If only one DUT input connect is conveniently available, connect to the PPG1 Data Out. Also, connect the coaxial terminator included as a standard accessory to the $\overline{\text{Data}}$ Out.
2. Connect the DUT optical output connector to O/E Data In using an optical fiber.
3. Connect the Sync Out to Trigger Clk Input using a coaxial cable.

 **CAUTION**

Check that the DUT optical output level does not exceed the rated optical input level for O/E Data In.

There is a risk of damaging the O/E module if the optical power exceeding the rated optical input level is applied to the O/E Data In connector.

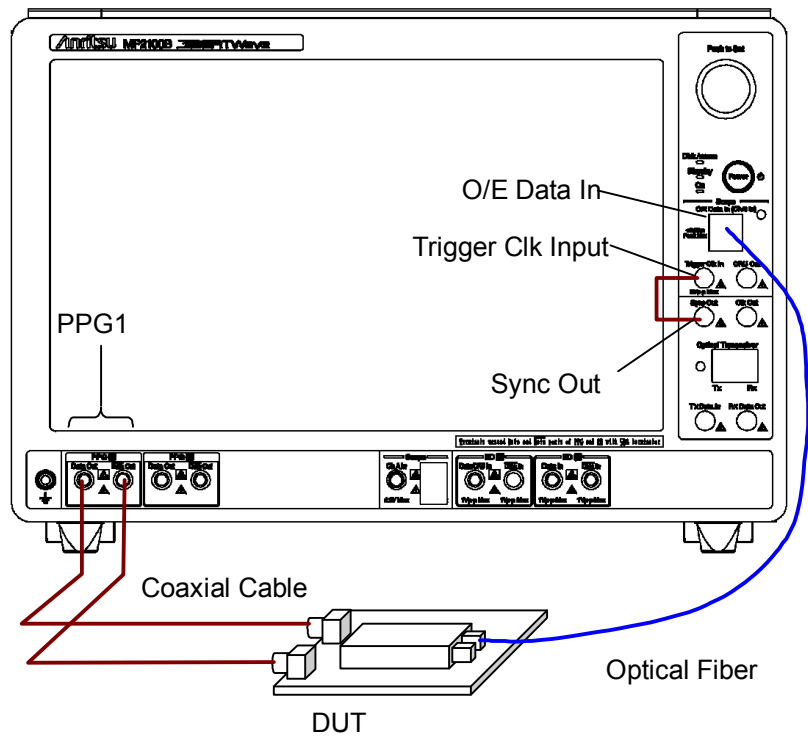

Figure 3.2-2 Optical Transceiver Used as DUT (Option 012, 023)

3
Connecting with DUT

When the DUT is an optical transceiver (using clock recovery)

The trigger clock can be generated from the received signal when the Option 023 is installed and the Option 054 is added.

1. Connect the CRU Out to Trigger Clk In using a coaxial cable.
2. Connect the PPG output to the DUT input connector using a coaxial cable.
3. Connect the DUT output and O/E Data In using an optical fiber.

 **CAUTION**

Check that the DUT optical output level does not exceed the rated optical input level for O/E Data In.

There is a risk of damaging the O/E module if the optical power exceeding the rated optical input level is applied to the O/E Data In connector.

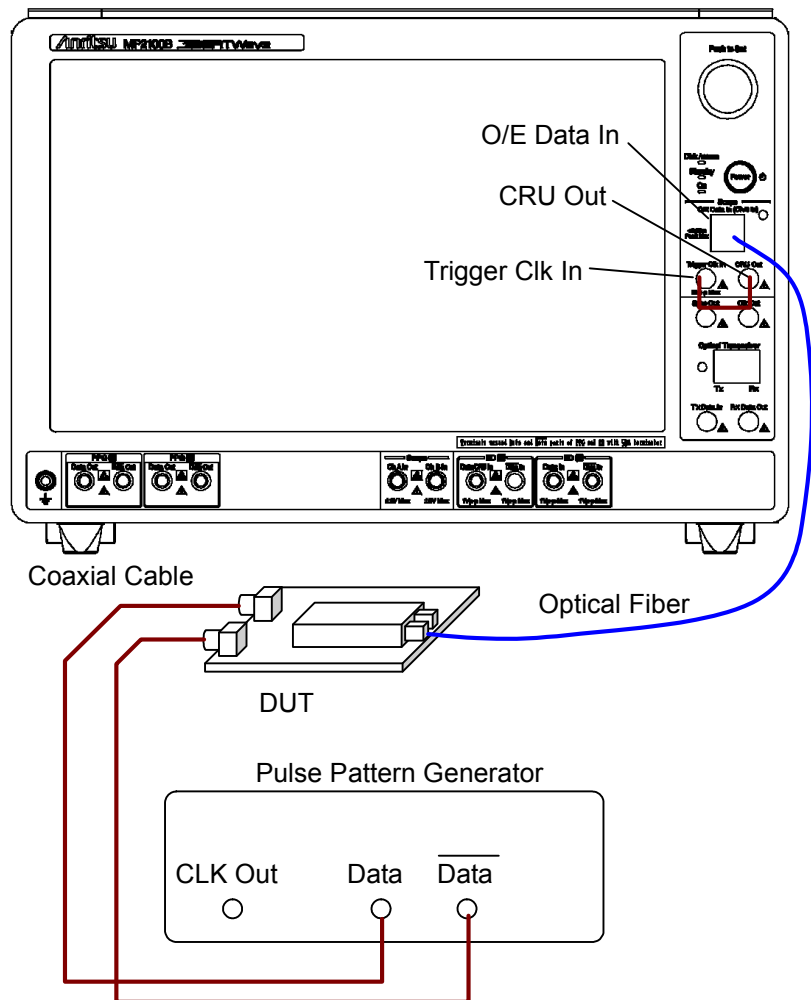

3

Connecting with DUT

Figure 3.2-3 Optical Transceiver Used as DUT (Option 023,054)

3.3 Simultaneously Measuring Bit Error Rate and Waveform

When the optical transceiver is set as the DUT, the reception sensibility of the optical receiver and the waveform of the optical transmitter can be measured simultaneously. To measure the reception sensibility of the optical receiver, the bit error rate must be measured using the measurement type that can change the optical level input to the DUT.

The connections are as follows when the Option 051 is added to the Option 012.

1. Connect the PPG2 Data Out to Tx Data In using a coaxial cable.
2. Connect the coaxial terminator provided with the BERTWave to PPG2 $\overline{\text{Data}}$ Out.
3. Connect the DUT output connect to ED2 $\overline{\text{Data}}$ In/Data In using a coaxial cable.
4. Connect the optical output connector of the BERTWave optical transceiver to the input connector of the optical attenuator using an optical fiber.
5. Connect the optical coupler to the output connector of the optical attenuator.
6. Connect one end of the optical coupler to the DUT input connector.
7. Connect another end of the optical coupler to the optical power meter.
8. Connect the DUT input connector to PPG1 $\overline{\text{Data}}$ Out and Data Out using the coaxial cable.
9. Connect the Sync Out to Trigger Clk Input using a coaxial cable.
10. Connect the DUT optical output connector to O/E Data In using an optical fiber.

An optical switch can be used in place of the optical coupler.

CAUTION

- Check the following before connecting the optical fiber:
 - The output power for the optical module inserted with the Option 051 is within the input level range for the DUT.
 - The DUT optical output level does not exceed the rated optical input level for O/E Data In.
- There is a risk of damaging the DUT or optical module if the optical power exceeding the rated optical input level is applied.

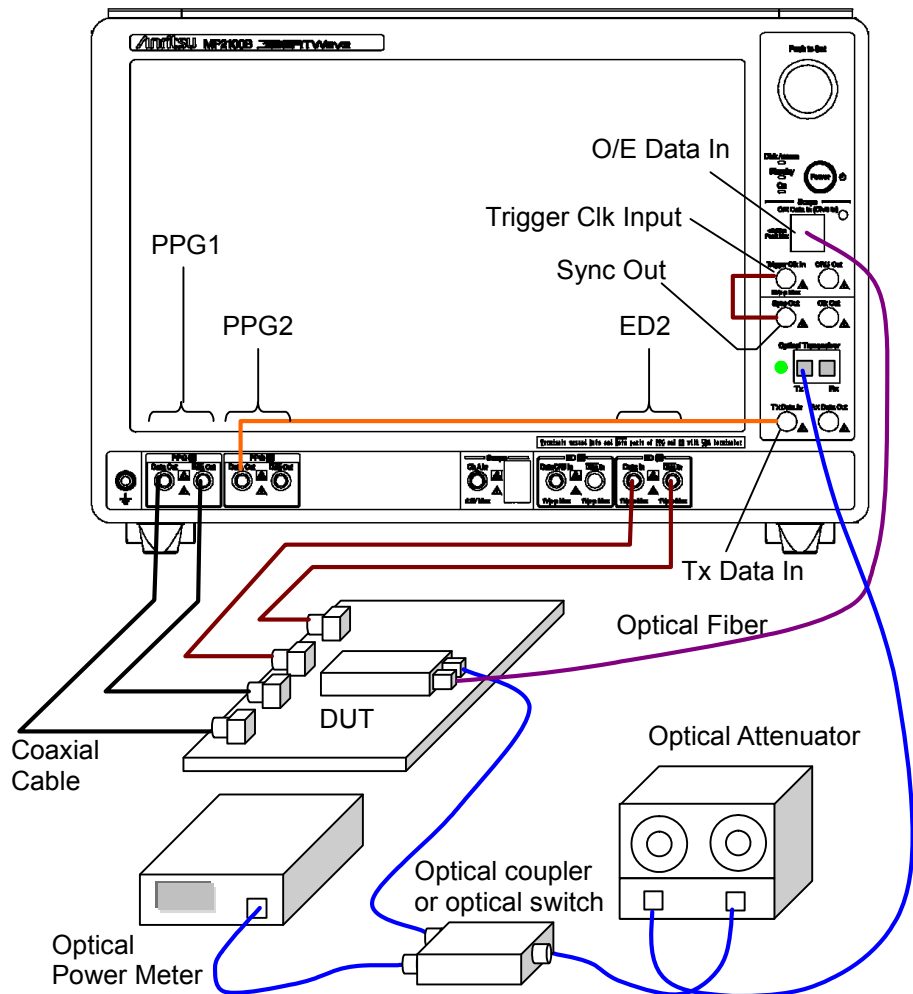

Figure 3.3-1 When Measuring Bit Error Rate and Waveform Simultaneously (Option 012, 023, and 051)

3.4 Measuring QSFP Module Bit Error Rate

The QSFP module contains four pairs of transmitters and receivers. With the Option 014, the QSFP Module bit error rate can be measured for four channels simultaneously.

If using a separate QSFP for transmission in addition to the DUT QSFP, connect as follows. Use coaxial cables of the same length as for between Data Out and $\overline{\text{Data}}$ Out to connect the BERTWave and QSFP. Bit error rate cannot be measured correctly if different length coaxial cables are used.

1. Connect the PPG1-PPG4 Data Out and Input connector on the transmission QSFP using a coaxial cable.
2. Connect the PPG1-PPG4 $\overline{\text{Data}}$ Out and Input connector on the transmission QSFP using a coaxial cable.
3. Connect the DUT QSFP output connector and ED1-ED4 Data In using a coaxial cable.
4. Connect the DUT QSFP output connector and ED1-ED4 $\overline{\text{Data}}$ In using a coaxial cable.
5. Connect the optical output connector of the transmission QSFP to the input connector of the optical attenuator using an optical fiber.
6. Connect the output connector of the optical attenuator to the optical coupler.
7. Connect one end of the optical coupler to the input connector of the DUT QSFP.
8. Connect the other end of the optical coupler to the optical power meter.

An optical switch can be used in place of the optical coupler.

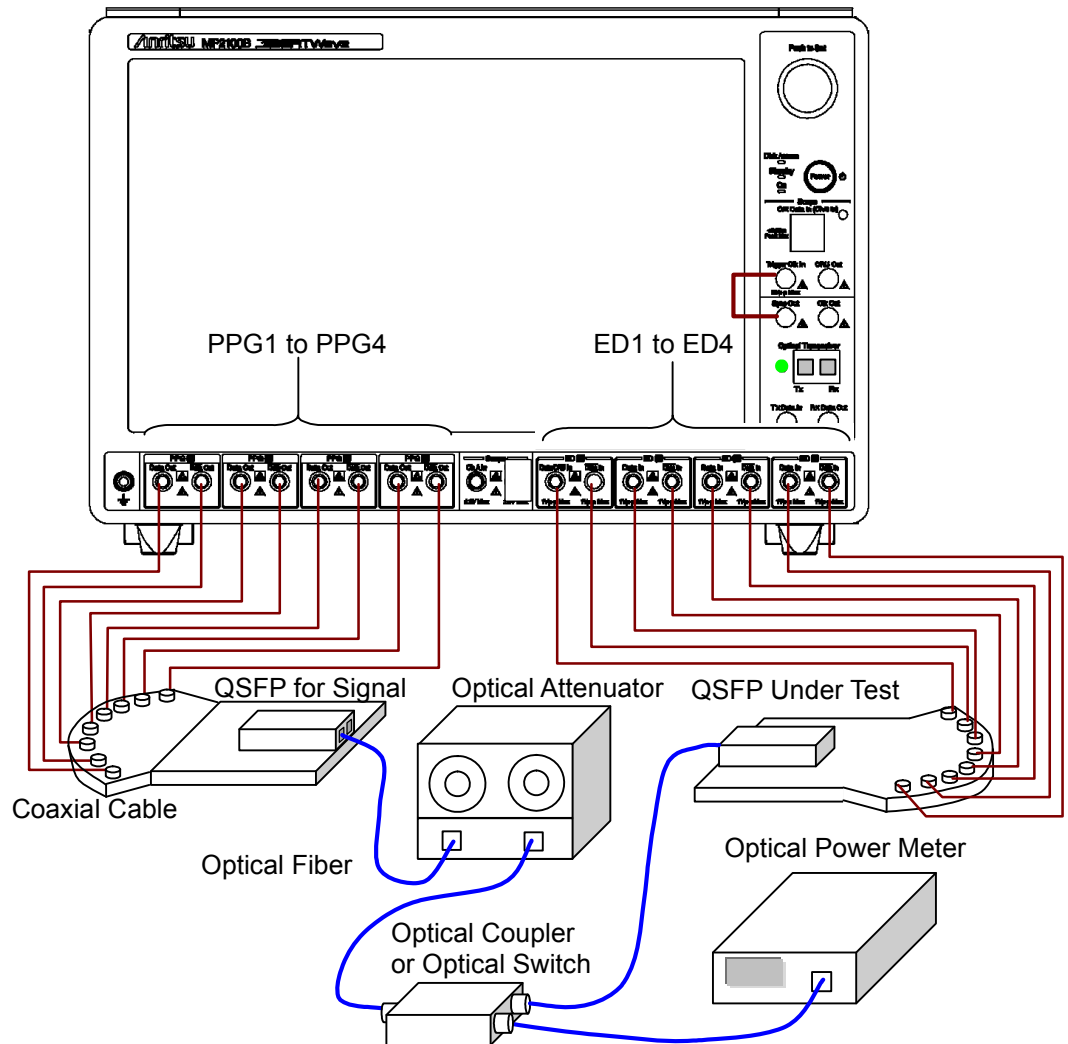

3
Connecting with DUT

Figure 3.4-1 Simultaneously Measuring Bit Error Rate for 4 Channels (Option 014)

⚠ CAUTION

Check that the optical output level input to the DUT QSFP does not exceed the rated optical input level.

There is a risk of damaging the QSFP module if the optical power exceeding the rated optical input level is applied.

Chapter 4 Screen Operation

This chapter explains the screen name and common operating method of the BERTWave series.

4.1	Screen Configuration	4-2
4.2	Data Input Method	4-5
4.3	Setting System Menu.....	4-8
4.4	Multi-channel Signal Output.....	4-15
4.5	Simultaneous Measurement Start and Stop at Multi-channels.....	4-16
4.6	Linking Measurement Settings for Multiple Channels	4-17
4.7	Displaying BER Measurement Results for Multiple Channels.....	4-18
4.8	Displaying Date/Time and Status	4-19
4.9	Actions to Take When System Alarm Occurs.....	4-20

4.1 Screen Configuration

Touch [Main Application] on the selector screen, and then the application screen is displayed.

Figure 4.1-1 shows the names of application screen elements.

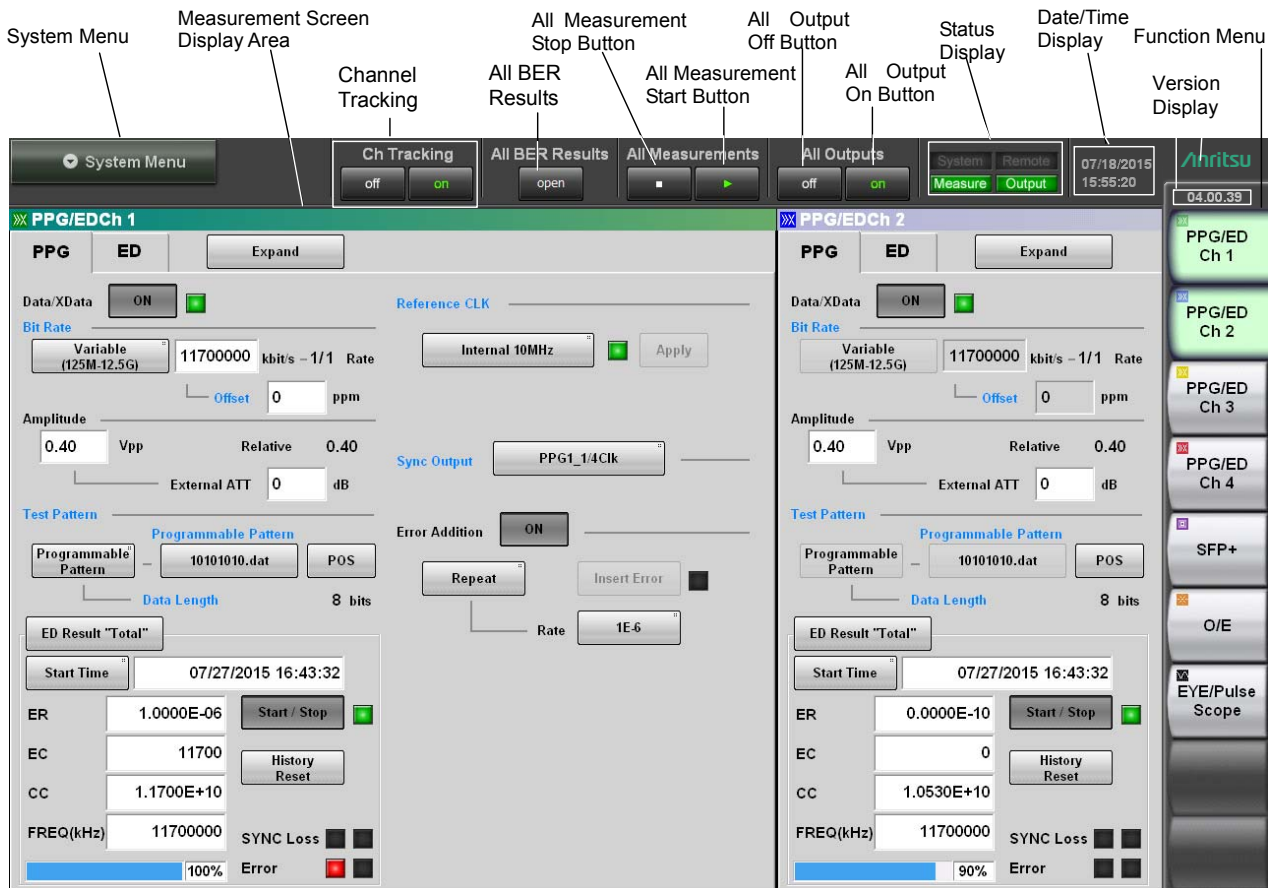

Figure 4.1-1 Names of Application Screen Elements

Table 4.1-1 Application Screen Elements

Name	Description
All BER Results	Displays the BER measurement results for multiple channels.
All Measurements	Starts and stops up to four channels of error rate measurement (Options 011, 012, 014) and two channels of waveform data (Options 021, 023) sampling at the same time.
All Outputs	Sets all PPG (Options 011, 012, 014) channels and optical transceiver (Option 051) output to On/Off at the same time.
Ch Tracking	Sets the bit rate, test pattern, PPG/ED tracking function, and gating for all channels to match the setting for channel 1. The Ch2 Reference Clk is set to [Ch1].
System Menu	The following setting button can be displayed: <ul style="list-style-type: none"> • Saving measurement conditions and measurement results • Reading measurement conditions • Saving screen image • Initializing device settings • Buzzer • Confirming system alarm and deleting records • Setting panel lock • Enabling panel lock and remote display • Connection diagram of device internal signal • Minimizing screen display • Terminating application
Function Menu	Selects the measurement device to be operated. The displayed measurement device varies depending on the model name and options.
Status display	The following four kinds of the status are displayed: <p>System: System alarm occurs</p> <p>Remote: Remotely controlled</p> <p>Measure: Measuring bit error rate and obtaining waveform data of sampling oscilloscope</p> <p>Output: Signal output from one of the PPG channels or from the optical transceiver</p>
Measurement screen display field	Displays the measurement screen selected at the function menu.
Date/Time display	Displays date and time set in the BERTWave.
Version display	Displays software version. Displayed in red if the version has not been updated. Refer to 10.5 “Updating Software” for details of how to update the software.

The buttons available on the function menu will vary depending on the installed options and software. The following table shows the relation between available buttons and installed options and software.

Table 4.1-2 Buttons Displayed on Function Menu

Function menu Button	Option						Software	
	011	012	014	051	021	023	MX210001A	MX210002A
PPG/ED Ch1	✓	✓	✓	–	–	–	–	–
PPG/ED Ch2	–	✓	✓	–	–	–	–	–
PPG/ED Ch3	–	–	✓	–	–	–	–	–
PPG/ED Ch4	–	–	✓	–	–	–	–	–
SFP+	–	–	–	✓	–	–	–	–
O/E	–	–	–	–	–	✓	–	–
EYE/Pulse Scope	–	–	–	–	✓	✓	–	–
Jitter	–	–	–	–	–	–	✓	–
Transmission	–	–	–	–	–	–	–	✓

Touching a Function Menu button displays the child screen for displaying the measurement conditions and results.

Refer to the following chapters for the child screen operations.

Function menu Button	Reference for operation details
PPG/ED	Chapter 5, Chapter 6
SFP+/XFP	Chapter 8
O/E	Chapter 8
EYE/Pulse Scope	Chapter 7
Jitter	<i>MX210001A Jitter Analysis Software operation manual</i>
Transmission	<i>MX210002A Transmission Analysis Software operation manual</i>

4.2 Data Input Method

The measurement setting item selection, numeric data, and character data are input from the panel displayed on the screen.

The displayed panel varies depending on the input data types.

Arrow Key Entry Panel

Touch the numeric data area when entering the numeric data of the bit rate or power voltage.

The arrow key entry panel as shown in Figure 4.2-1 is displayed.

Touch the right and left arrow keys and select the line to change the value.

Touch the up and down arrow keys or turn the rotary knob to change the value.

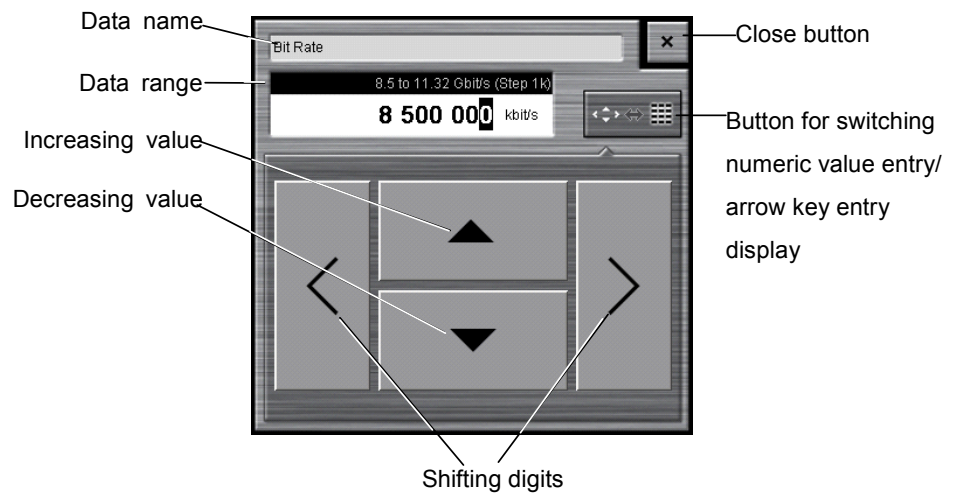

Figure 4.2-1 Arrow Key Entry Panel

Numeric value entry panel

Touch the button for switching the display of the numeric value entry/ arrow key entry panel as shown in Figure 4.2-1, and then the numeric value entry panel as shown in Figure 4.2-2 is displayed. The key type, unit and input range displayed on the panel vary depending on the data.

Touch the arrow key entry panel display button, and then the arrow key entry panel as shown in Figure 4.2-1 is displayed.

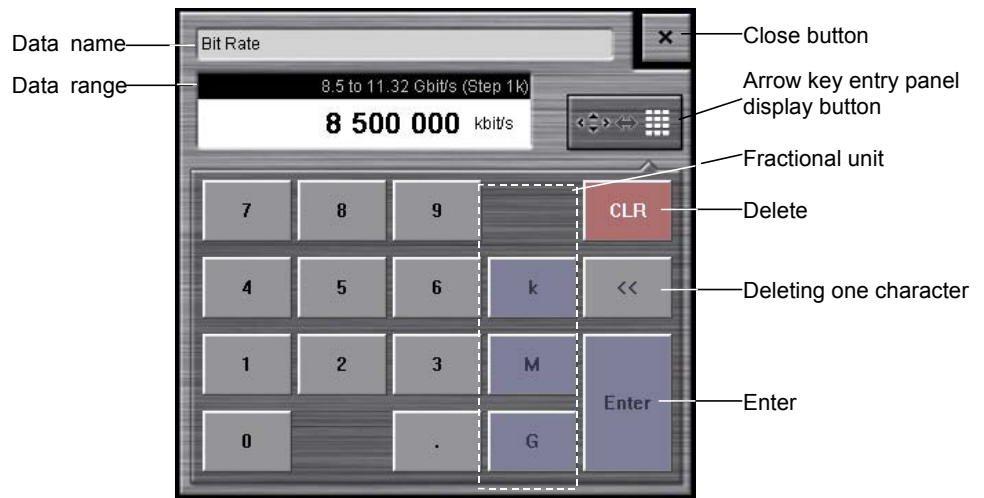

Figure 4.2-2 Numeric Value Entry Panel

Software Keyboard

When entering character string data such as file name, touch the [Screen Keyboard]. The keyboard as shown in Figure 4.2-3 is displayed, and then touch the key and enter the character. If you touch [Shift] or [Caps] once, all keys are locked. To unlock them, touch [Shift] or [Caps] again.

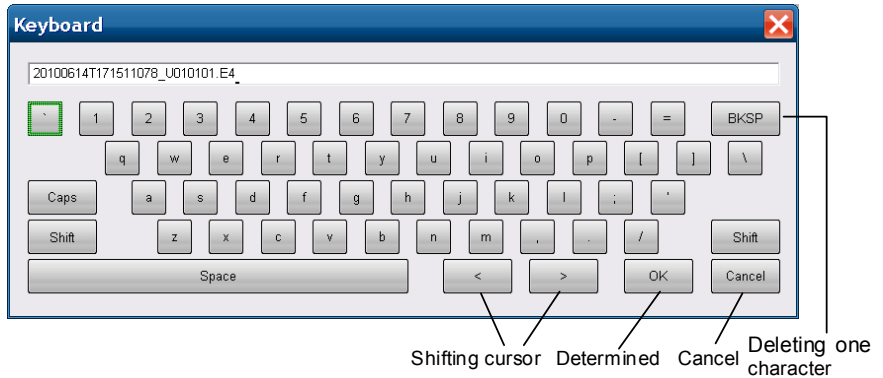

Figure 4.2-3 Software Keyboard

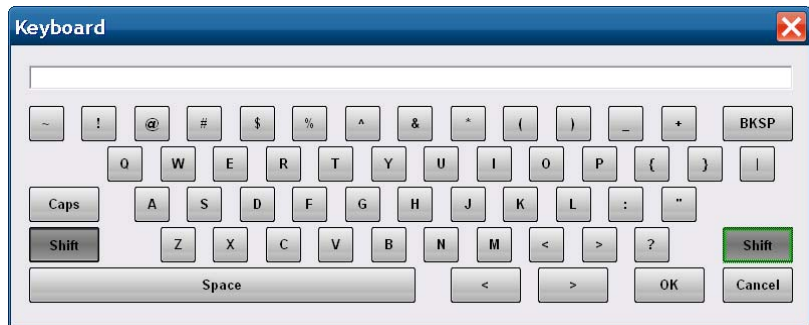

Figure 4.2-4 Software Keyboard (Shift Locked)

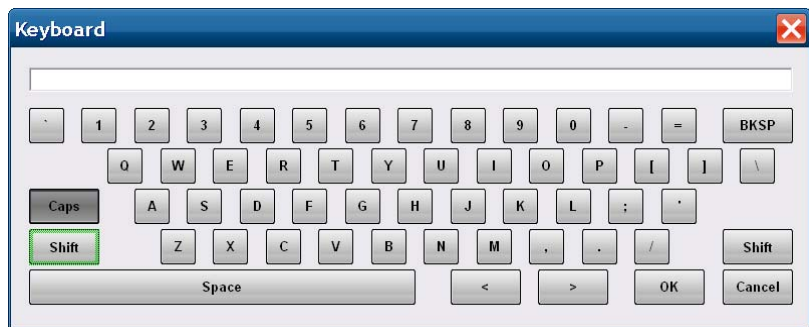

Figure 4.2-5 Software Keyboard (Caps Key Locked)

4.3 Setting System Menu

The following items can be set and confirmed at the system menu.

- Saving measurement conditions and measurement results
- Reading measurement conditions
- Saving screen image
- Initializing device settings
- Buzzer
- Confirming system alarm and deleting records
- Setting panel lock
- Enabling panel lock and remote display
- Connection diagram of device internal signal
- Minimizing screen display
- Terminating application

To set the system menu, touch [System Menu] as shown in Figure 4.3-1.



Figure 4.3-1 System Menu

Saving measurement conditions and measurement results

1. Touch [Save] to display the Save panel.
2. Select the save data from the following:
[All Setup], [PPG/ED Ch1], [PPG/ED Ch2], [PPG/ED Ch3], [PPG/ED Ch4], [SFP+], [EYE/Pulse Scope], [O/E], [Jitter], [Transmission]
The displayed module varies with the model name and options.
3. When [PPG/ED Ch1], [PPG/ED Ch2], [PPG/ED Ch3], [PPG/ED Ch4], [EYE/Pulse Scope], [Jitter], or [Transmission] is saved, select the data type from the following:
[Setting]: Measurement condition
[Result]: Measurement result
4. The file name is displayed. When changing the displayed file name, touch the keyboard display button.

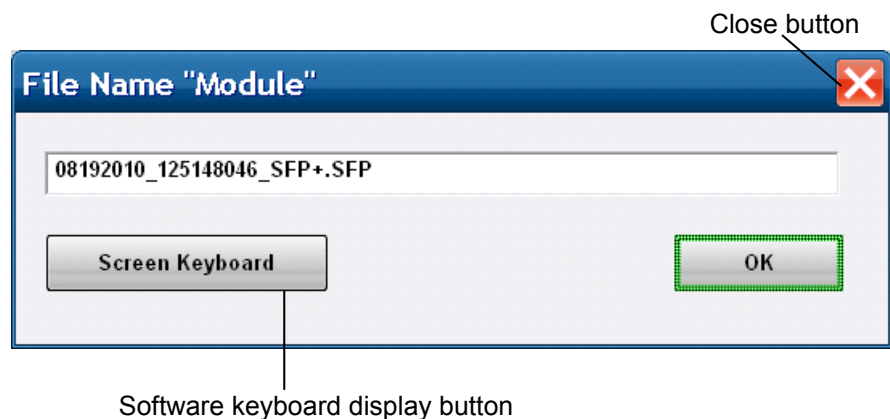

5. Enter the file name using the software keyboard.
6. When saving the file name, touch [OK]. Also, when canceling the saving procedure, touch the close button.

The measurement condition file is saved in the following folder.

C:\Program Files\Anritsu\MP2100A\MX21000A\UserData\Setting

The measurement result file is saved in the following folder.

C:\Program Files\Anritsu\MP2100A\MX21000A\UserData\Result\CSV

C:\Program Files\Anritsu\MP2100A\MX21000A\UserData\Result\TXT

The CSV file cannot be read in the spreadsheet software.

You can confirm the test file details on the test editor.

Reading measurement conditions from file

1. Touch [Open] to display the Open panel.
2. Select the target module form the following:
[All], [PPG/ED Ch1], [PPG/ED Ch2], [PPG/ED Ch3], [PPG/ED Ch4],
[SFP+], [EYE/Pulse Scope], [O/E], [Jitter], [Transmission]
The displayed module varies with the model name and options.
3. The file selection screen is displayed.

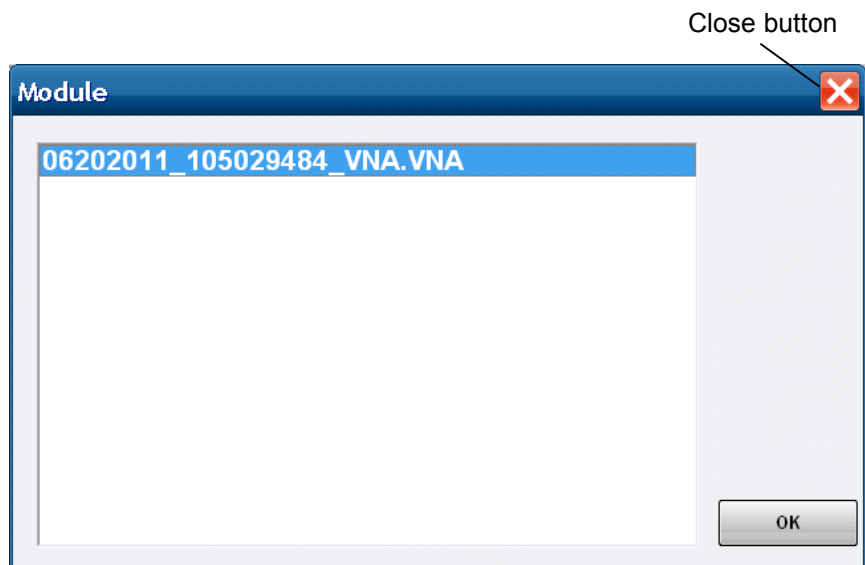

4. Touch the file to be read.
5. When reading the file, touch [OK]. On the other hand, when canceling the procedure, touch the close button.

Saving a screen to the image file

1. Touch [Screen Copy] .

The file selection screen is displayed.

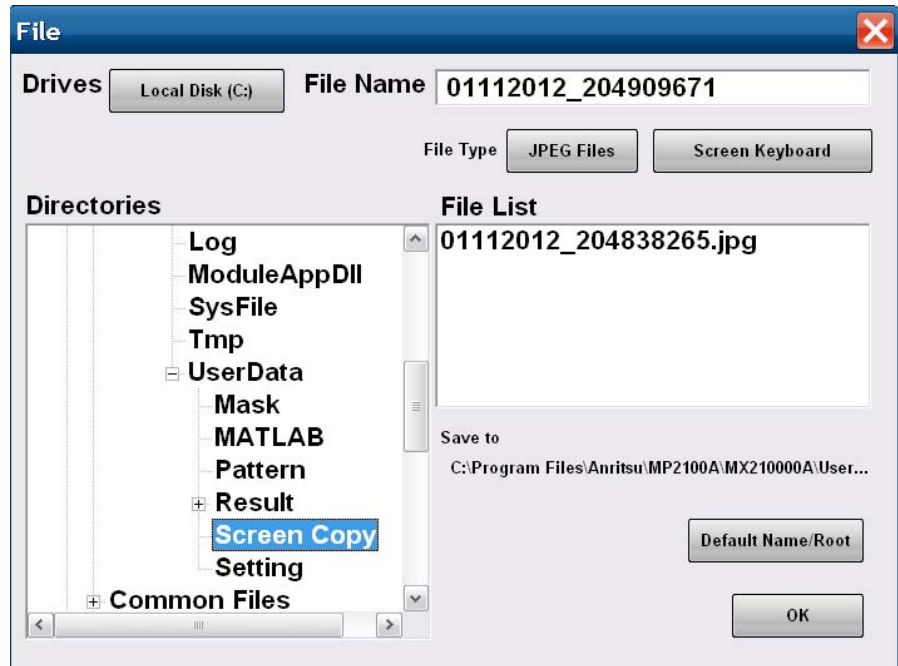

2. Touch the Drives button and the Directories display to set the saving destination folder. The file name is displayed in the Save to.
3. The file format to be saved is displayed in the right button of the file type. Touching the button can set the file format.
4. When inputting the file name, touch [Screen Keyboard] to set the file name.
5. When overwriting the existence file, touch the file name displayed in the File List.
6. Touch [OK] to save the screen file.
When overwriting the screen file, the confirmation message is displayed.

When touching [Default Name/Root], the folder and file names are set to the initial values.

The initial value of the folder is as follows.

C:\Program Files\Anritsu\MP2100A\MX21000A\UserData\Screen Copy

The initial value of the file name is configured as date and time.

For example, file 523 saved at 12:05:55 on 17 July 2015 will have the following file names:

For [JPEG Files]: 17072015_120555523.jpg
For [PNG Files]: 17072015_120555523.png

Initializing measurement conditions

1. Touch [Initialize]. Then, the dialog box indicating the initialization process is displayed.
2. Touch [OK] to initialize the measurement condition and touch [Cancel] to stop the initialization.
When overwriting the screen file, the confirmation message is displayed.

Setting buzzer

The BERTWave can sound a buzzer when a System Alarm or error/alarm occurs for bit error rate measurement.

1. To sound the buzzer at panel operations, touch [Buzzer Off].
2. The button display changes to [Buzzer On].
In this condition, the buzzer sounds when either of the following occurs:
 - Error/Alarm at bit error rate measurement
 - System Alarm
3. Touch [Buzzer On] to release the buzzer.
The button display changes to [Buzzer Off].



Figure 4.3-2 Buzzer Button

Displaying alarm

1. Touch [System Alarm].
The alarm occurred history is displayed on another window.
2. When closing the window, touch [OK]. On the other hand, when deleting the alarm history, touch [Clear].

Touch the Auto Popup button to set the display to [ON]. When Alarm occurs, the System Alarm screen is displayed automatically.

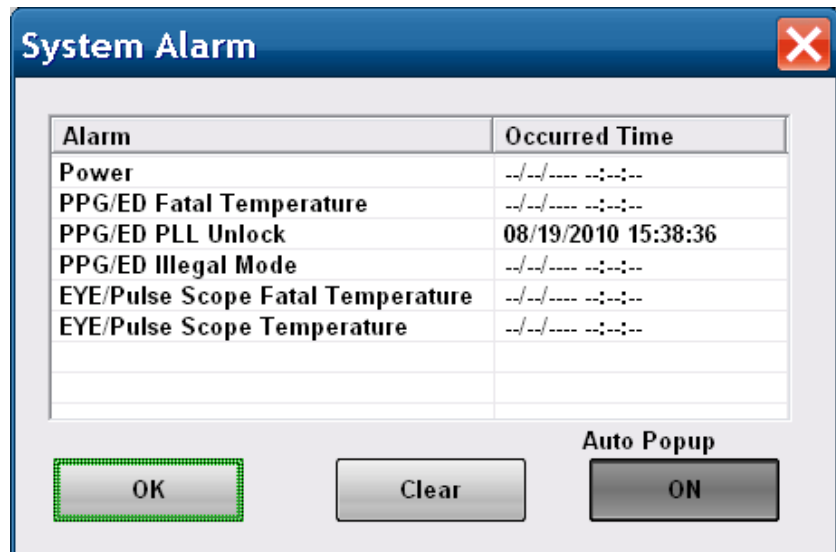

Figure 4.3-3 System Alarm Occurred Time

The displayed time indicates the time when alarm occurred first. If the multiple alarms occur, the time after the second alarm is not record.

Note:

When the system alarm occurs, the system alarm screen is displayed automatically. Also, when the next alarm occurs, the power supply is turned off after 10 seconds

- Power
- PPG/ED Fatal Temperature
- EYE/Pulse Scope Fatal Temperature

Panel locking

Preventing screen operations at menus other than the System Menu is called panel locking.

1. Touch [Panel Lock] to lock the panel.
2. The screens other than the system menu, status display, and date/time display are shaded and displayed.

Even though the panel is locked, the system menu and power switch are enabled.

If the panel is locked, the [Local/Panel Unlock] button at the system menu can be operated.

When the BERTWave performs the measurement via a remote control, the panel is locked.

Unlocking the panel

1. Touch [Local/Panel Unlock].
2. The Remote lamp at the status display goes off.

Displaying the device internal signal connection

1. Touch [Block Diagram].
2. The device internal block diagram is displayed, so the clock and signal connection can be confirmed.
3. Touch [OK] or the close button, and then the block diagram is closed.

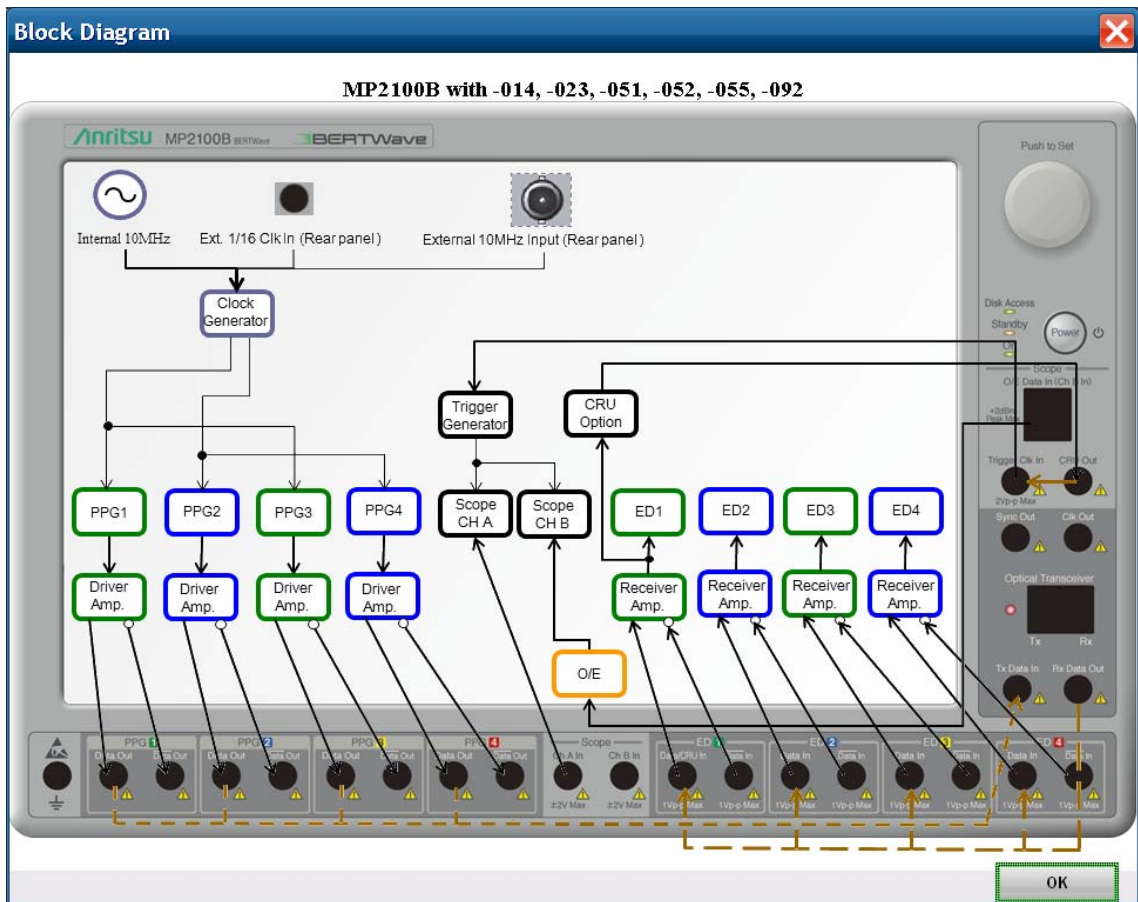

Figure 4.3-4 Example of Block Diagram

Minimizing the screen display

1. Touch [Minimize] to display the desk top.
[MX210000A] is displayed on the task bar.
2. To display the screen, touch [MX210000A] on the task bar.

Terminating applications

1. Touch [Exit]. The dialog box is displayed to confirm the application termination.
2. When terminating the applications, touch [Yes]. On the other hand, when canceling the application termination, touch [No].
3. The selector screen is displayed.

4.4 Multi-channel Signal Output

The BERTWave can set PPG channels 1 to 4 and optical transceiver output to On/Off at the same time.

To output signal of PPG and optical transceiver:

1. Touch [On] as shown in Figure 4.4-1.
2. The characters of [on] are changed to green and then the Output lamp for the status display is turned on.

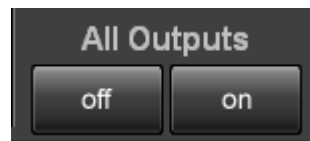

Figure 4.4-1 All Outputs Button

The optical signal of the PPG and optical transceiver is output.

To stop the signal output from the PPG and optical transceiver:

1. Touch [off] as shown in Figure 4.4-1.
2. The characters of [on] are changed to white and then the Output lamp for the status display is turned off.

The data signal output is stopped for all the PPG channels 1 to 4. The optical output of the optical transceiver is also stopped.

Note:

All Output button is set to [off] after starting the Main Application at the Selector screen.

4.5 Simultaneous Measurement Start and Stop at Multi-channels

This BERTWave can measure error rates for four channels and sample waveform data for two channels simultaneously.

To start simultaneous measurement, touch the [▶] key shown in Figure 4.5-1 while the Measure lamp is lit.

To stop simultaneous measurement, touch the [■] key shown in Figure 4.5-1 while the Measure lamp is lit off.

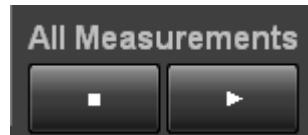

Figure 4.5-1 All Measurements Button

4.6 Linking Measurement Settings for Multiple Channels

Ch Tracking is displayed for the Options 012 or 014.

Touching [on] sets the PPG and ED settings for Ch1 to the PPG and ED settings for other channels. In this state, altering settings for Ch1 also alters the settings for other channels.

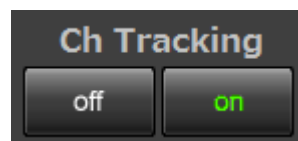

Figure 4.6-1 Ch Tracking

The following settings are linked:

- Programmable Pattern
- Data Length
- ED Tracking*
- ED Gating Cycle (Repeat/Single/Untimed)
- ED Gating Period

*: Setting Ch Tracking to On sets ED Tracking to On. However, setting Ch Tracking to Off does not set ED Tracking to Off.

Setting Ch Tracking to On sets the Ch2 Reference CLK to [Ch1].

4.7 Displaying BER Measurement Results for Multiple Channels

All BER Results is displayed for the Options 012 or 014.

Touching [Open] displays the BER measurement results for all channels.

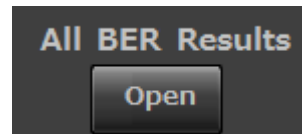

Figure 4.7-1 All BER Results



Figure 4.7-2 All BER Results Display

Table 4.7-1 All BER Results Screen Settings

Name	Description
All Ch Start/Stop	Starts/stops BER measurement for all channels. The sampling oscilloscope measurement is not started/stopped.
All History Reset	Resets the History lamp for all channels.
Close	Exits the All BER Results display.

The All BER Results display does not close even if the Top Menu function button is touched.

4.8 Displaying Date/Time and Status

To display date and time

Date and time is displayed on the upper right side of the screen.

Date and time can be changed from the Windows control panel.

To display status

The following four kinds of indicators indicate the status.

Table 4.8-1 Indicator status

Indicator	Status
System	System Alarm
Remote	Remote Control
Measure	Measuring bit error rate or acquiring waveform data of sampling oscilloscope
Output	A signal is output from one of the PPG channels or from the optical transceiver.

4

Screen Operation

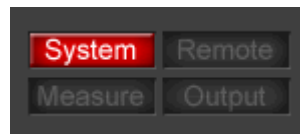

Figure 4.8-1 System Alarm Occurred



Figure 4.8-2 Remote Control

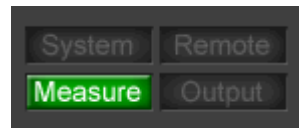

Figure 4.8-3 Displays at Bit Error Rate Measurement and Waveform Data Capture

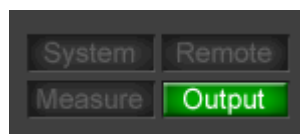

Figure 4.8-4 Display when PPG Signal is Output

4.9 Actions to Take When System Alarm Occurs

The following phenomena cause a system alarm.

Power

Abnormal power supply

The Power alarm is displayed when this system detects a low internal voltage.

The BERTWave shuts down automatically after this alarm is displayed. Before using this instrument, check that the voltage of the power supply meets the voltage specifications. If the voltage of the power supply is within specifications and the Power alarm is displayed, contact Anritsu or your sales agent.

PPG/ED Fatal Temperature

Eye/Pulse Scope Fatal Temperature

High temperature warning (Temperature, Fatal Temperature)

When the internal temperature reaches 90°C, the temperature alarm is displayed.

When Fatal Temperature is displayed, the power of the BERTWave is shut down.

Verify that the ventilation openings are unobstructed and that the fan is running. Turn off the unit and allow the temperature to cool down.

EYE/Pulse Scope Temperature

EYE/Pulse Scope calibration is necessary. Calibrate it according to Section 7.5 “Calibrating Sampling Oscilloscope”.

PPG/ED Hardware Error

Hardware error

In the event of PPG/ED Hardware Error, contact an Anritsu Service and Sales office.

You can check the system alarm occurred time from [System Menu] – [System Alarm].

Chapter 5 *Generating Pulse Signal*

To measure the bit error rate or monitor a waveform, first a signal for input to the device under test (DUT) must be generated. In these measurements, a pulse signal with a time cycle is used. This chapter explains how to generate the pulse pattern signal while setting the output waveform and data pattern of the PPG.

5.1	List of Setting Items	5-2
5.2	Setting Restrictions	5-9
5.3	Procedure for Generating Pulse Signal	5-10
5.4	Setting Reference Clock	5-11
5.5	Setting Output Waveform	5-16
5.6	Setting Patterns	5-20
5.7	Inserting Bit Error	5-25
5.8	Setting Sync Output	5-26

5.1 List of Setting Items

The following table items can be set using the PPG.

Table 5.1-1 Setting Items of PPG

Item	Description
Reference CLK	Selects the clock to be used from the following items: Internal 10MHz: Use the internal clock based on the internal 10 MHz transmitter Ext 10MHz In: Use the external clock input from the External 10 MHz Input connector Ext 1/16 In: Use the external clock input from the Ext Clk In connector Ch1: (Only available for Ch2) Use the clock synchronized with the Ch1 clock
Apply	Synchronizes the external clock with the internal pattern generation circuit if the Reference CLK is set to Ext 1/16 In. Check that the Reference CLK status display is yellow after inputting the external clock before touching the button.
Data/XData	Sets the connector signal output On/Off.
Bit Rate	Sets the bit rate when Bit Rate Standard is set to Variable.
Bit Rate Standard	Selects the communication specifications applying to the bit rate.
Bit Rate Offset	Changes bit rate in range of -100 to +100 ppm corresponding to value set at Bit Rate
Divide Ratio	Indicates the ratio between the frequency of the internal frequency synthesizer and the bit rate. The button appears allowing the divide ratio to be set when Reference CLK has been set to [Ext 1/16 In].
Amplitude	Sets the amplitude voltage of the signal to be output from the Data Out and Data Out connectors.
External Attenuator Factor	Inputs attenuation amount when attenuator inserted at connector
Test Pattern	Selects the pattern from PRBS or Programmable Pattern. Sets the signal level of the Data connector responding to Pattern 1.
POS/NEG	Sets the signal level of the Data connector responding to Pattern 1.
Programmable Pattern	Selects the pattern file name when Test Pattern is set to Programmable Pattern. The file name selected is displayed.
Sync Output	Selects the signal output to the Sync Output connector.
Error Addition	Sets whether to add bit errors to the test pattern.
Error Addition—Mode	Sets whether to insert bit error continuously, or insert one by one by touching [Insert Error].
Error Addition—Rate	Sets the rate at which bit errors are generated when the Error Addition mode is Repeat.
Insert Error	Inserts one bit error to the pattern when the Error Addition mode is Single.
Output Display	Displays the data signal output status.

Table 5.1-2 Setting Items of PPG

Item	Description
Reference CLK Status Display	Displays the reference clock synchronization status. Red: Reference clock cannot be detected. Yellow: Reference clock was detected, but is not synchronized with pattern data. Green: Reference clock is synchronized with pattern data.
Relative	Displays the amplitude voltage calculated by the set value at External Attenuator Factor.
Data Length	Displays the pattern length as bits.

To display the PPG setting screen

1. Touch [PPG/ED_Ch1], [PPG/ED_Ch2], [PPG/ED_Ch3], or [PPG/ED_Ch4] at the function menu.
2. Touch [PPG], and then Figure 5.1-1 is displayed.
3. Touch [Main], and then Figure 5.1-2 is displayed.
4. Touch [Expand], and then the screen is changed to Figure 5.1-1.

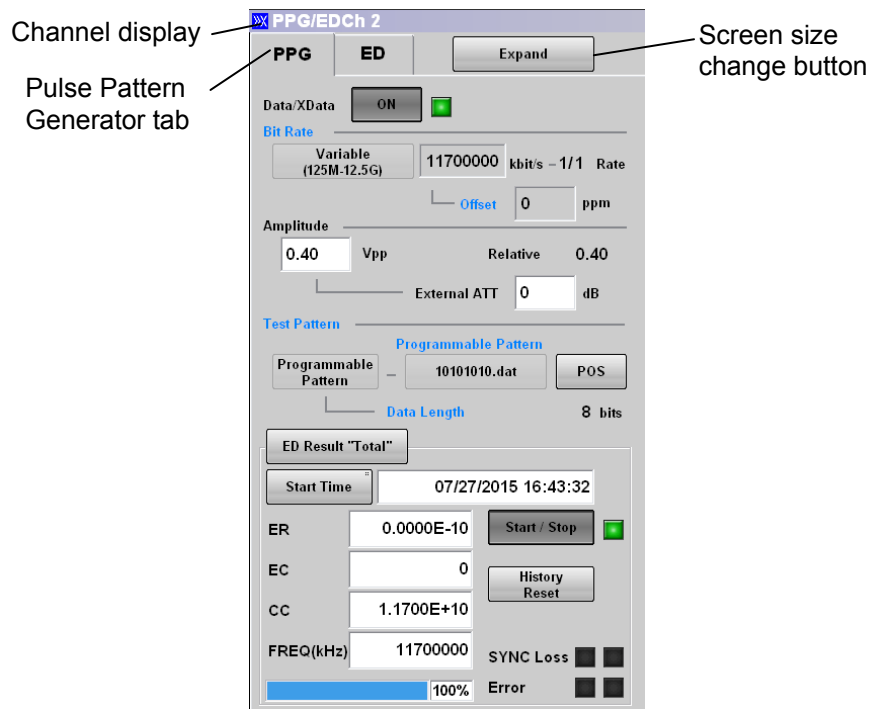

Figure 5.1-1 PPG Setting Panel

XData in Figure 5.1-1 indicates the $\overline{\text{Data}}$ Out connector on the front panel.

For the display and operation of ED Result, refer to 6.6 “Measurement Result”.

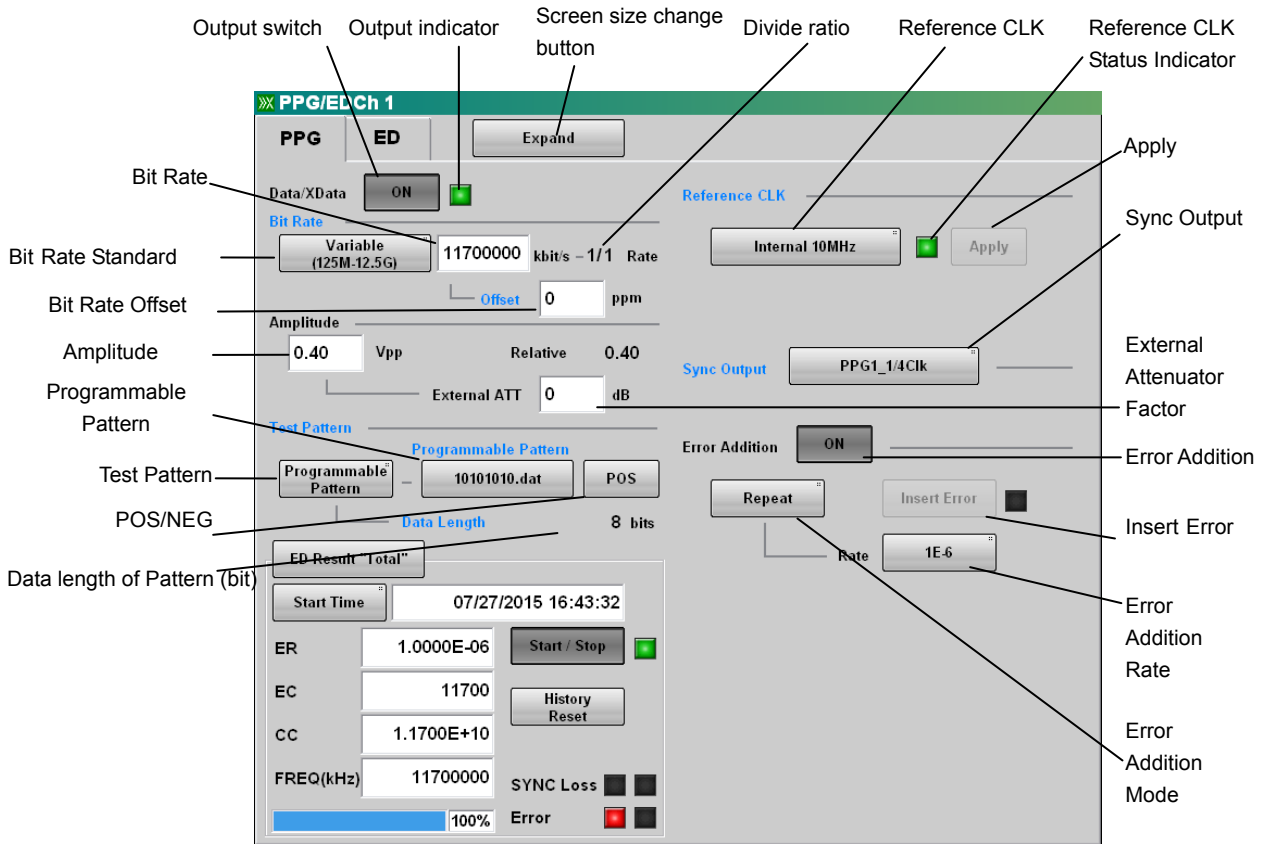

Figure 5.1-2 PPG Setting Panel (Details)

The PPG setting range is as follows:

Amplitude

0.10 to 0.80 V_{p-p}

Bit Rate

Variable*1

125 000 to 12 500 000 kbit/s

Offset

-100 to 100 ppm

1GFC

2GFC

4GFC

8GFC

10GFC

10GFC-FEC

1GbE

2GbE

CPRI

CPRI-2

CPRI-4

CPRI-5*2

CPRI-10*2

Infiniband

Infiniband×2

Infiniband×4

10GbE WAN

10GbE LAN/PHY

10GBASE-LRM

10GSFP+Cu

10GbE OTU1e

10GbE OTU2e

40GBASE-CR4

40GBASE-SR4

40GBASE-LR4

OBSAIRP3*2

OBSAIRP3×2*2

OBSAIRP3×4*2

OBSAIRP3×8*2

OC-3/STM-1

OC-12/STM-4

OC-24

OC-48/STM-16

OTU-1

OC-192/STM-64

G.975 EFC
OTU-2
Rate*3
1/1
1/2
1/4
1/8
1/16
1/32
1/64
Data/XData
Off
On
Error Addition
Off
On
Repeat
1E-2
1E-3
1E-4
1E-5
1E-6
1E-7
1E-8
1E-9
1E-10
1E-11
1E-12
Single
Insert Error
External Attenuation
0 to 30 dB
Reference CLK
Internal 10MHz
Ext 10MHz In
Ext 1/16 In
Ch1*4
Sync Output
PPG1_1/1 Clk*5,
PPG1_1/2 Clk*6
PPG1_1/4 Clk*7
PPG1_1/8 Clk*8
PPG1_1/16 Clk*9
PPG1_1/64 Clk*8

PPG2_1/1 Clk*5,*10
 PPG2_1/2 Clk*6,*10
 PPG2_1/4 Clk*7,*10
 PPG2_1/8 Clk*8,*10
 PPG2_1/16 Clk*9,*10
 PPG2_1/64 Clk*8,*10
 ED1_1/4 Clk*11
 ED1_1/8 Clk*12
 ED1_1/16 Clk
 ED2_1/4 Clk*10,*11
 ED2_1/8 Clk*10,*12
 ED2_1/16 Clk *10
 ED3_1/4 Clk*11,*13
 ED3_1/8 Clk*12,*13
 ED3_1/16 Clk*13
 ED4_1/4 Clk*11,*13
 ED4_1/8 Clk*12,*13
 ED4_1/16 Clk*13
 PPG1_Pattern Sync
 PPG2_Pattern Sync*10
 PPG3_Pattern Sync*13
 PPG4_Pattern Sync*13
 Test Pattern
 PRBS2^7-1
 PRBS2^9-1
 PRBS2^15-1
 PRBS2^23-1
 PRBS2^31-1
 Programmable Pattern
 POS/NEG
 NEG
 POS

- *1: Refer to Table 5.1-1 for the setting ranges when the Option 092 is not added.
- *2: When with the Option 092 added
- *3: When Reference CLK is Ext 1/16
- *4: Can be set with Ch2.
- *5: 1/4, 1/8, 1/16, 1/32, 1/64 at Rate display
- *6: 1/2, 1/4 at Rate display
- *7: 1/1, 1/2 at Rate display
- *8: 1/1 at Rate display

*9: 1/1, 1/2, 1/4 at Rate display

*10: Option 012 or 014

*11: 1/2 at ED rate display

*12: 1/1 at ED rate display

*13: Option 014

5.2 Setting Restrictions

The setting items of the PPG have the following restrictions.

The clock and bit rate cannot be set for Ch3 or Ch4 with the Option 014.

The clock and bit rate values will always be the same as for Ch1 or Ch2.

5.3 Procedure for Generating Pulse Signal

The basic procedure is as shown in the following figure.

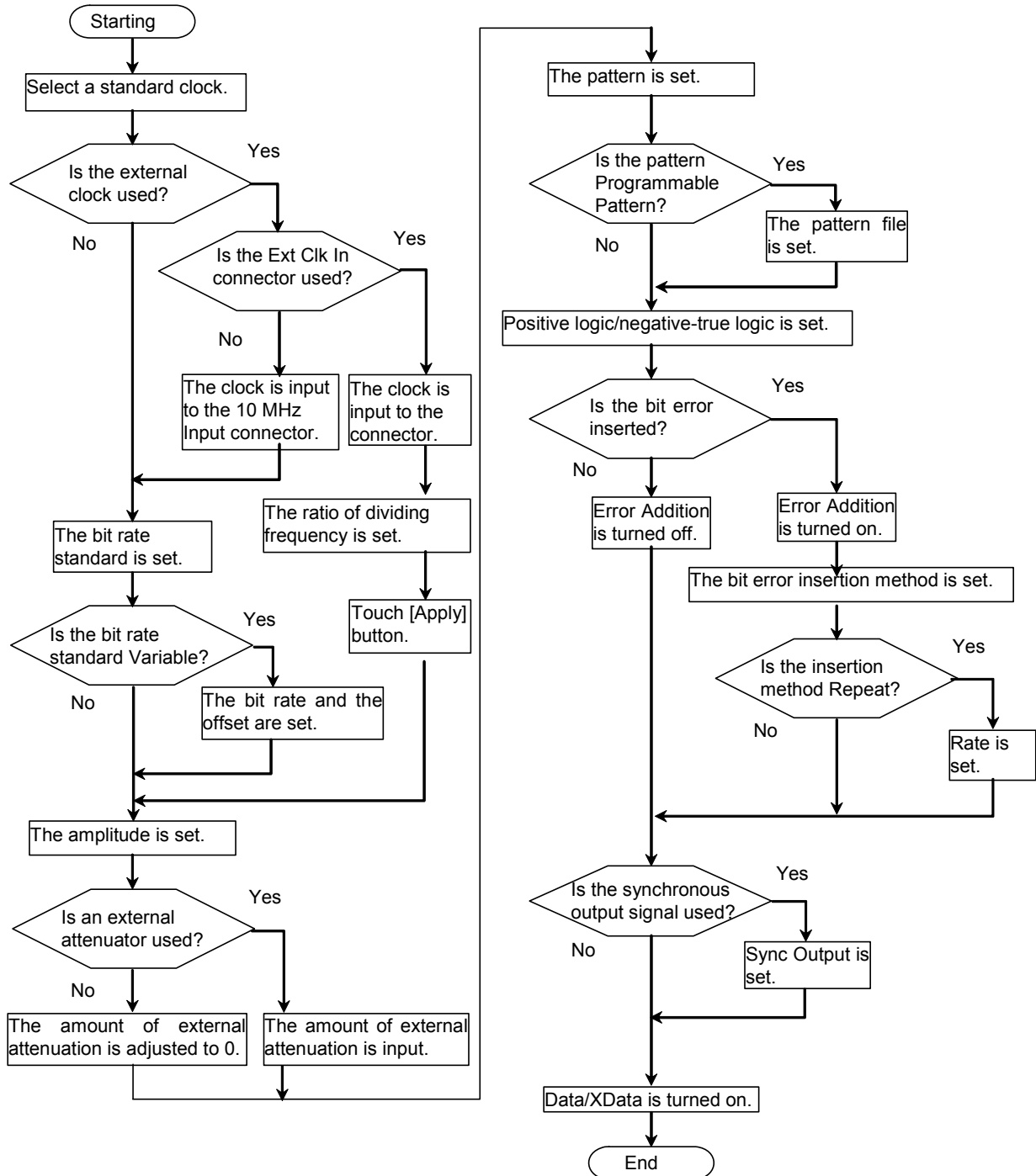

Figure 5.3-1 Basic Procedure of Generating Pulse Signal

5.4 Setting Reference Clock

The PPG uses the reference clock to generate the data.

The reference clock can be selected from the following supply sources:

- Internal clock generated inside the BERTWave
- External clock input from the Ext Clk In connector
- External clock input from the External 10 MHz Input connector

The internal clock accuracy is ± 10 ppm after power is applied for 1 hour.

The external clock is used under the following conditions:

- When synchronizing other equipment with clock
- When using clock with higher accuracy than internal clock

The Ext Clk In connector is an AC coupling.

1/16 clock frequency range displayed in the bit rate specifications [Variable] is input to Ext Clk In connector.

The bit rate of the signal output from the BERTWave is calculated by the following formula.

$$Br = f_{EXT} \times 16 \times R$$

Br: Bit rate (kbit/s)

f_{EXT} : Clock frequency (kHz) input to the Ext Clk In connector

R: Divide Ratio (1/1, 1/2, 1/4, 1/8, 1/16, 1/32, 1/64)

Example: When setting the bit rate to 9953280 kbit/s, input the clock frequency (622080 kHz) and set the divide ratio to 1/1.

The External 10 MHz Input connector is a DC coupling.

The 10 MHz clock of the sine wave or short waveform is input to the External 10MHz Input connector.

With the Options 012 and 014, the reference clock can be set separately for channels 1 and 2.

Table 5.4-1 Reference CLK Settings

Reference CLK	Description
Internal 10MHz	Use the internal clock based on the internal 10 MHz transmitter
Ext 10MHz In	Use the external clock input from the External 10 MHz Input connector
Ext 1/16 In	Use the external clock input from the Ext Clk In connector
Ch1	(Only available for Ch2) Use the clock synchronized with the Ch1 clock

Note:

Always touch [Apply] if using the external clock.

Improving PPG phase differences by synchronizing clock with Ch1
When Reference Clock is set to Internal at the Option 012 or 014, the data rates of PPG1 and PPG2 become the same but there is phase error in the data. Although phase error between PPG1 and PPG2 has no effect on the measurement results when measuring bit errors, sometimes non-existent jitter may be observed at waveform monitoring.

Setting the Ch2 Reference Clock setting to Ch1 will improve the phase difference for this data.

Use the clock synchronized to the PPG1 data as the oscilloscope trigger to display the monitored PPG2 Eye Pattern as follows.

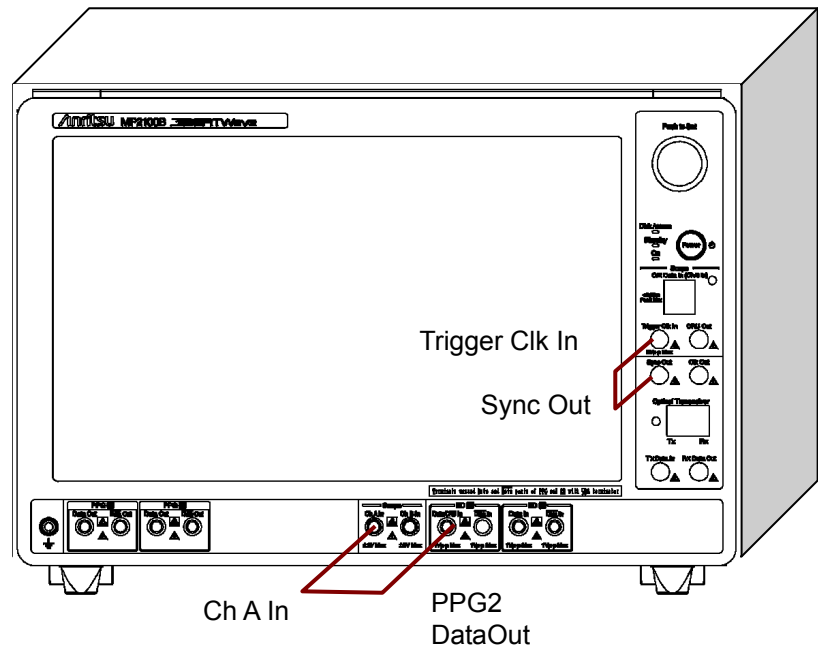

Set Sync Output to PPG1_1/4 Clk.

Figure 5.4-1 Eye Pattern Monitoring

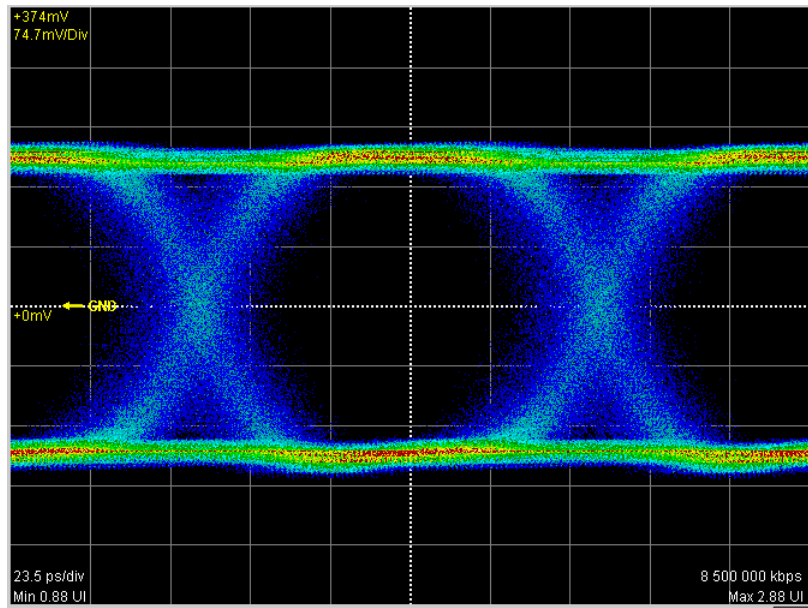

Figure 5.4-2 Eye Pattern when Reference Clock is Internal

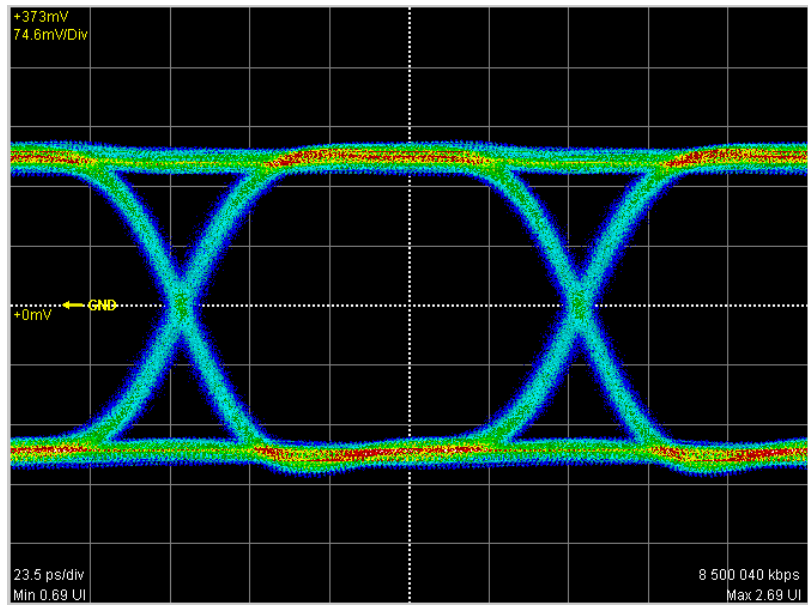

Figure 5.4-3 Eye Pattern when Reference Clock is Ch1 Synchronized

5

Generating Pulse Signal

When monitoring the waveforms of two DUTs simultaneously, make the following connections.

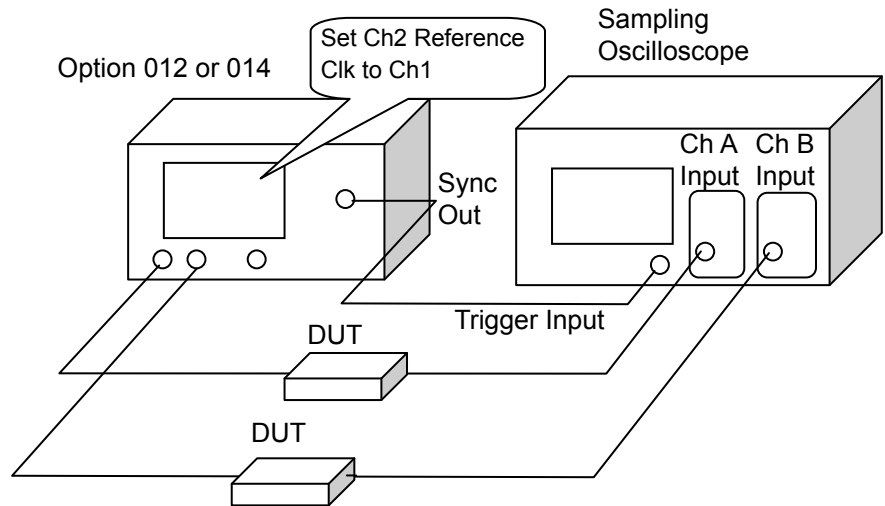

Figure 5.4-4 Setup for Simultaneous Monitoring of Two Channels

Set the Ch2 Reference Clock to Ch1 even when the measurement system includes long-distance transmission.

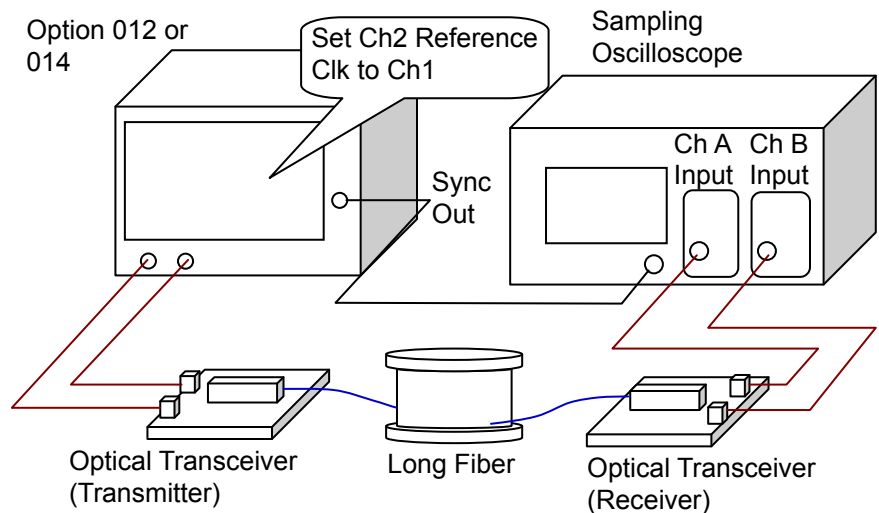

Figure 5.4-5 Measurement System Including Long-distance Transmission

Procedures:

1. Touch the screen size change button, and set to [Expand].
2. Touch the Reference CLK button.
The selection screen is displayed. The number of the displayed buttons vary with the option configuration.
3. Touch the reference clock button, referring to Table 5.4-1.

 **CAUTION**

- The impedance of the Ext Clk In and External 10 MHz Input connectors is 50 Ω . Measurement may not be performed correctly if a cable with another impedance is used.
 - The amplitude of the signal input to the Ext Clk In connector is 1.6 Vp-p max. This is equivalent to +8 dBm for a sine-wave signal. Inputting a signal with a larger voltage risks damaging the internal circuits.
 - The signal input to the Ext Clk In connector is 0.2 Vp-p minimum. This is equivalent to -10 dBm for a sine-wave signal. Measurement may not be performed correctly if a signal with a larger voltage is input.
 - The amplitude of the signal input to the External 10 MHz Input is 2 Vp-p max. This is equivalent to +10 dBm for a sine-wave signal. Inputting a signal with a larger voltage risks damaging the internal circuits.
 - The amplitude to the External 10 MHz Input is 0.7 Vp-p minimum. This is equivalent to 0.9 dBm for a sine-wave signal. Measurement may not be performed correctly if a signal with a larger voltage is input.
-

5.5 Setting Output Waveform

The PPG output terminal is the PPG $\overline{\text{Data}}$ and Data connectors on the front panel.

The connector block diagram is as shown below.

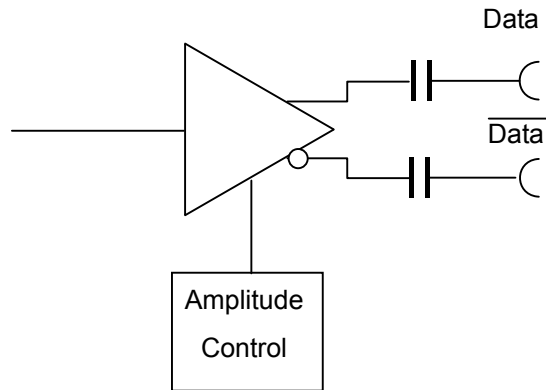

Figure 5.5-1 Output Terminal Block Diagram

The connector is an AC coupling.

When it is necessary to impose DC voltage on an output waveform, connect a bias-T.

CAUTION

- The impedance of the Data Out and $\overline{\text{Data}}$ Out connectors is 50 Ω . Measurement may not be performed correctly if a coaxial cable with another impedance is used or if the impedance of the DUT is not 50 Ω .
 - The amplitude of signal output to the Data Out and $\overline{\text{Data}}$ Out connectors is 0.1 to 0.8 Vp-p. Check that the output voltage amplitude does not exceed the DUT maximum input specifications. If it does, connect an attenuator to the output connector.
-

Set the bit rate and amplitude of the waveform output to the Data and Data connectors.

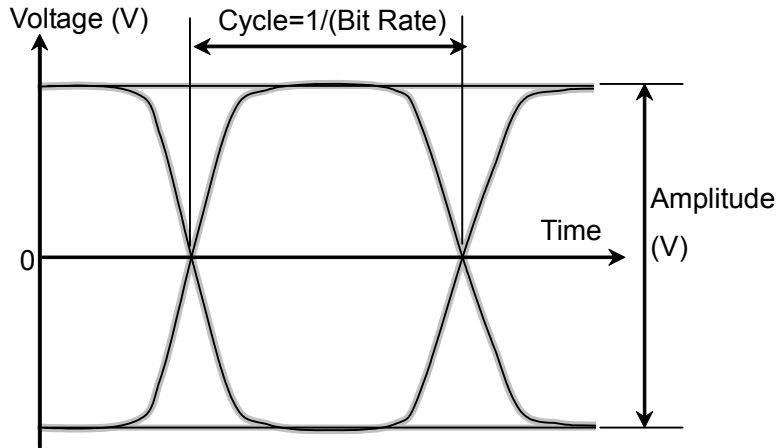
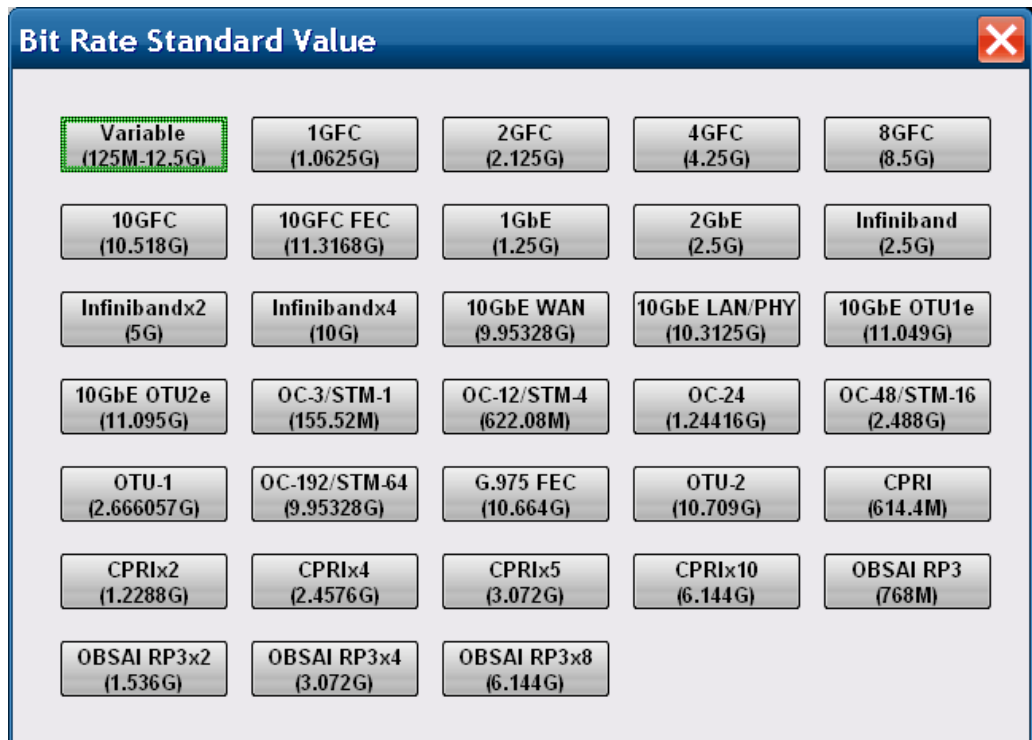

Figure 5.5-2 Waveform Setting Item

To set bit rate

Set the bit rate when Reference CLK has been set to [Internal 10MHz] or [Ext 10MHz In].

1. Touch the Bit Rate button.
The window is opened to select the specifications.
The number of the displayed buttons varies with the options.



2. Touch the bit rate specifications button.
The number displayed in the button is the specified bit rate (bit/s).
When indicating 1.25G, this means 1.25 Gbit/s.
3. When selecting [Variable], touch the bit rate and offset text boxes and input the value. The bit rate can be set in the range 125 MHz to 12.5 GHz, and the offset can be set in the range -100 to 100 ppm.
If the Option 092 is not included, select [Variable], [Variable-1/2], [Variable-1/4], [Variable-1/8], [Variable-1/16], [Variable-1/32], [Variable-1/64], and input values in the ranges shown in Table 5.5-1.

Table 5.5-1 Bit Rate Setting Ranges Without Option 092

Specifications	Bit Rate (kbit/s)
Variable	8 500 000 to 11 320 000
Variable-1/2	4 250 000 to 5 660 000
Variable-1/4	2 125 000 to 2 830 000
Variable-1/8	1 062 500 to 1 415 000
Variable-1/16	531 250 to 707 500
Variable-1/32	265 625 to 353 750
Variable-1/64	132.813 to 176 875

To set amplitude

1. Touch the Amplitude text box and set the amplitude voltage.
2. Insert an attenuator between the Data Out connector and the Data Out connector, and touch the External Attenuation text box and input the attenuation. The amplitude voltage after passage through the attenuator is displayed in Relative.

 **CAUTION**

When inserting attenuator at both the Data Out connector and Data Out connector, use an attenuator with the same amount of attenuation.

If the attenuation amounts are different, the displayed amplitude and the amplitude output at the connector will be different.

The following are the specifications for the voltage level of the high-speed interface.

Table 5.5-2 lists the specified signal amplitude.

Table 5.5-2 Signal Specifications and Amplitude

Specifications	Amplitude (V)
ECL	0.8
LVDS	0.35
LVPECL	0.8
NCML	0.5
NECL	0.8
PCML	0.5
PECL	0.8

5.6 Setting Patterns

The following two test patterns can be selected.

- PRBS
- Programmable Pattern

PRBS

PRBS is the pattern generated at the hardware.

The generated pattern length, maximum length of contiguous 1s, and maximum length of contiguous 0s differ depending on the hardware configuration.

The following block diagram indicates the hardware generating PRBS 2^7-1 .

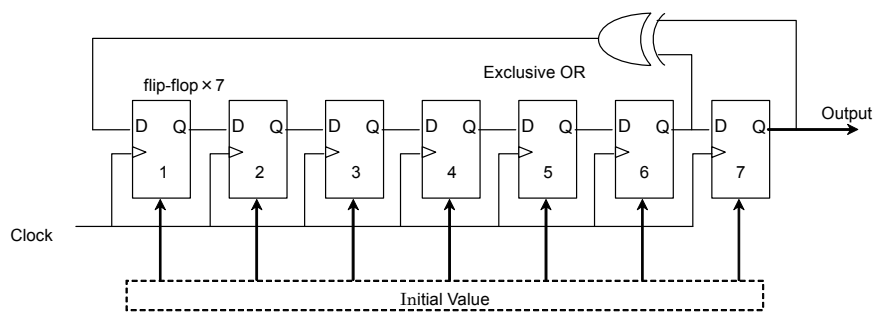

Figure 5.6-1 Block Diagram for PRBS Generating Circuit

This block diagram is composed of a shift register composed of a seven-stage flip-flop and an Exclusive OR circuit. A signal of the sixth and seventh stages of the shift register are input to the Exclusive Or and the output of the Exclusive Or is input to the shift register. This type of configuration is described by the following pattern generation polynomial.

$$1+X^6+X^7$$

When inputting the default value of 7 bits and impressing the clock, a pattern with a bit length of $2^7-1 = 127$ is repeatedly generated. The default value of seven bits includes 1 or more “1” bits.

The following shows the pattern length, maximum number of contiguous 1s, and maximum number of contiguous 0s using the PRBS generation formula of the BERTWave.

PRBS	Pattern Generation Polynomial	Pattern Length	Maximum number of contiguous 1s	Maximum number of contiguous 0
2^7-1	$1+X^6+X^7$	127	7	6
2^9-1	$1+X^5+X^9$	511	9	8
$2^{15}-1$	$1+X^{14}+X^{15}$	32767	15	14
$2^{23}-1$	$1+X^{18}+X^{23}$	8388607	23	22
$2^{31}-1$	$1+X^{28}+X^{31}$	214748647	31	30

The ratio of 1s to the PRBS pattern length is 50%.

Programmable Pattern

The Programmable Pattern is the pattern defined by the pattern file.

The Programmable Pattern is used when the following patterns are required:

- Frame format pattern such as Ethernet and SDH
- Pattern captured from communication circuit data
- Specified test pattern

The restrictions when using the Programmable Pattern are:

- The occurrence ratio of “1” is 50% with ± 1 bit tolerance.
- The pattern length is 1305600 bits or less. When the file data length is over 1305600 bits, the first 1305600 bits are used.
- When using pattern files created for existing Anritsu products, use Pattern A only when the pattern file type is Alternate.

Pattern Logic

There are two types of logic: Positive Logic (POS) and Negative Logic (NEG).

With positive logic, the voltage at the Data connector goes High when the data is “1”.

With negative logic, the voltage at the Data connector goes Low when the data is “1”.

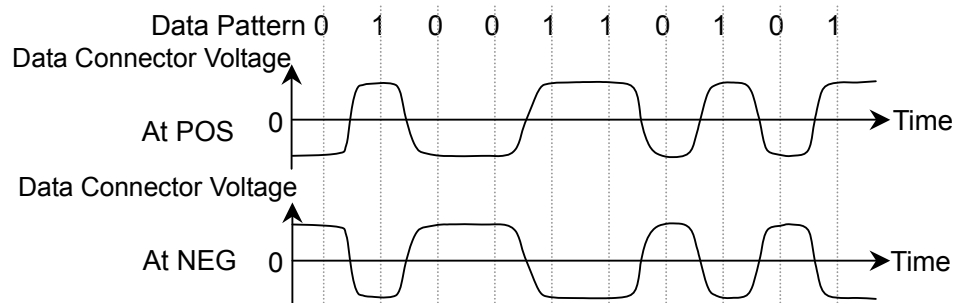
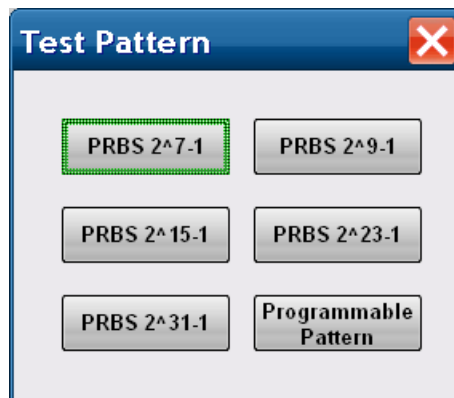

Figure 5.6-2 Relationship between Logic Setting and Output Voltage Waveform at Connector

Set the pattern using the following procedure.

1. Touch the button for Test Pattern (in Figure 5.1-2, its name is “Programmable Pattern”), and you will see the Test Pattern dialog box.



2. Touch the button for the pattern you want to set.
3. If you select [Programmable Pattern], the button for Programmable Pattern on the right becomes active. Touch the button, and you will see the Programmable Pattern dialog box.

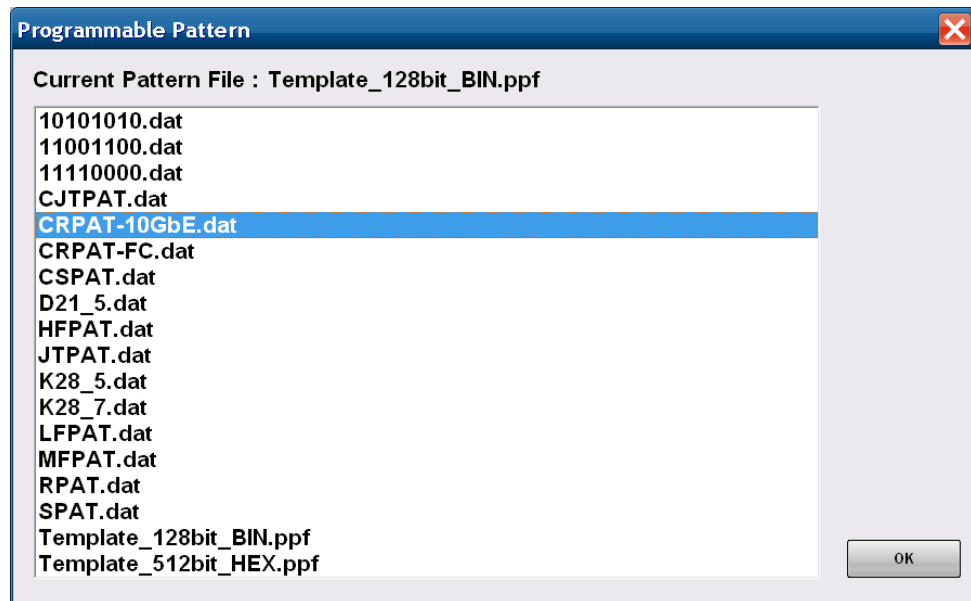

4. Touch the file name.
5. Touch [OK].
To cancel file selection, touch the **Close** button.
6. Touch the button on the right of [Programmable Pattern] to set [POS] or [NEG].

Note:

If "-----" is displayed in the **Programmable Pattern** box, a repeated pattern of "0" and "1" is output.

The BERTWave can read the previous product's pattern file (the file extension is PCP or PTN). The compatibility with the previous product file is as shown in the following table.

The file must be saved in the following folder before reading these files.
C:\Program Files\Anritsu\MP2100A\MX210000A\UserData\Pattern

Table 5.6-1 File Compatibility with Previous Product

Product Name	File extension	Pattern	Supported/Not supported
MU181020A MU181020B	PTN	Data	✓
		Alternate	✓ *
		Mixed (Data)	✓
		Mixed (Alternate)	✓ *
		Sequence	✓
MP1758A	PTN	PRGM 1ch	✓
		PRGM 2ch	✓
		PRGM 4ch	✓
		PRBS	–
MP1761A MP1761B MP1761C	PTN	ALT	✓
		Data	✓
		PRBS	–
		Zero-Subst	–
MP1775A MP1776A	PTN	PRGM 1ch	✓
		PRGM 2ch	✓
		PRGM 4ch	✓
		PRBS	–
		Zero-Subst 1ch	–
		Zero-Subst 2ch	–
		Zero-Subst 4ch	–
MP1632A MP1632C	PTN	PRGM	✓
		Zero-Subst	–
		PRBS	–
	PCP	PRGM	✓

*: Only pattern A can be read.

5.7 Inserting Bit Error

Insert a bit error when confirming whether to detect the bit error at the ED. Bit errors can be inserted either by inserting bits one at a time using screen operation or by inserting a fixed rate to the bit string.

Inserting bit errors one bit at a time using screen operation

1. Touch the button under Error Addition and set to [Single].
2. Touch the Error Addition button and set the button display to [On].
3. Touch [Insert Error], and then 1 bit error is inserted.
When inserting the bit error, the indicator on the right side of [Insert Error] lights green.

Inserting fixed proportion of bit errors

1. Touch the button under Error Addition to set to [Repeat].
2. Touch the Rate button. Select the bite error rate from the following list:

[1E-2]:	10^{-2}	[1E-8]:	10^{-8}
[1E-3]:	10^{-3}	[1E-9]:	10^{-9}
[1E-4]:	10^{-4}	[1E-10]:	10^{-10}
[1E-5]:	10^{-5}	[1E-11]:	10^{-11}
[1E-6]:	10^{-6}	[1E-12]:	10^{-12}
[1E-7]:	10^{-7}		

3. Set Error Addition to [On].

To stop bit error insertion, set Error Addition to [Off].

The average time interval for generating bit errors depends on the Rate and Bit Rate as shown in the following table.

Table 5.7-1 Average Time Interval for Generating Bit Errors

Rate	Bit Rate (kbit/s)					
	155520	622080	1250000	2488320	4250000	10000000
1E-4	64.3 μ s	16.1 μ s	8 μ s	4.02 μ s	2.35 μ s	1 μ s
1E-6	6.43 ms	1.61 ms	800 μ s	402 μ s	235 μ s	100 μ s
1E-8	643 ms	161 ms	80 ms	40.2 ms	23.5 ms	10 ms
1E-10	64.3 s	16.1 s	8 s	4.02 s	2.35 s	1 s
1E-12	6430 s	1608 s	800 s	402 s	235 s	100 s

5.8 Setting Sync Output

Set the signal type output from the front-panel Sync Out connector. Sync Output connector outputs either a pulse synchronized to the data generated by the PPG, or a pulse synchronized to the data received by the ED, and outputs it at the front-panel Sync Out connector. When measuring the bit error rate and waveform using another error detector or sampling oscilloscope, the Sync Out signal is connected to the measurement equipment. The Sync Out Connector is a DC coupling.

The output of the Sync Output connector is input either to a sampling an oscilloscope trigger to monitor the PPG waveform.

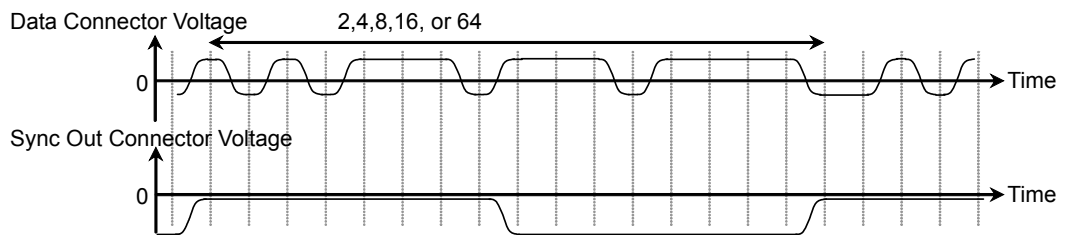

Figure 5.8-1 Correspondence between Sync Output Setting and Output Voltage Waveform at Connector using PPG or ED Rate Division

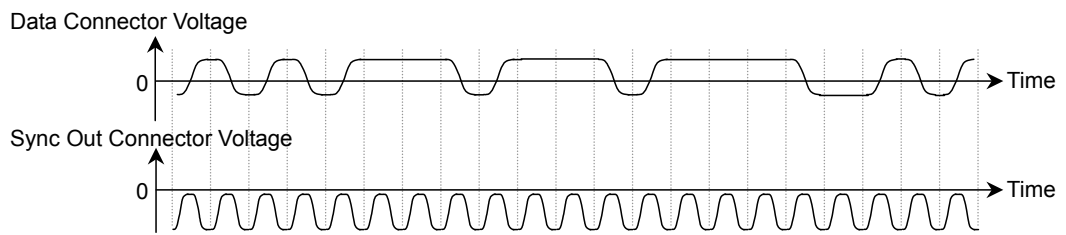

Figure 5.8-2 Correspondence between Sync Output Setting and Output Voltage Waveform at Connector using PPG 1/1

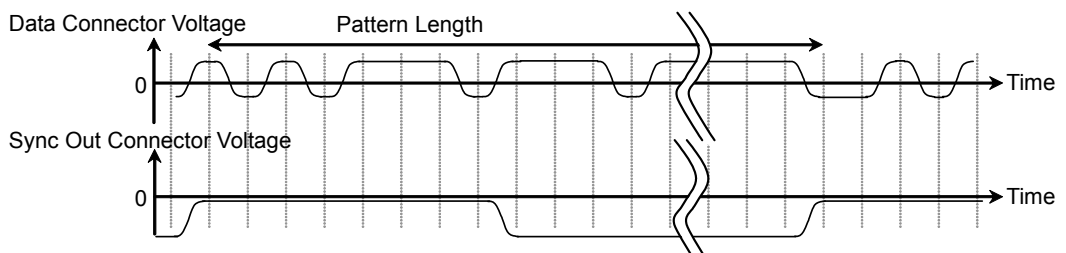

Figure 5.8-3 Voltage Waveform Output to Connector Corresponding to Sync Output Setting for PPG Pattern Sync

The Sync Output amplitude cannot be set.

The time interval outputting the pulse varies depending on the pattern length and bit rate when Sync Output is PPG Pattern Sync .

Select the pattern for the measurement referring to Table 5.8-1.

Table 5.8-1 Cycle of Sync Output (PPG Pattern Sync)

Pattern Name	Bit Rate (kbit/s)					
	155520	622080	1250000	2488320	4250000	10000000
PRBS 2 ⁷ -1	52.3 μs	13.1 μs	6.5 μs	3.27 μs	1.91 μs	812 ns
PRBS 2 ⁹ -1	210 μs	52.6 μs	26.2 μs	13.1 μs	7.70 μs	3.27 μs
PRBS 2 ¹⁵ -1	13.48 m s	3.37 ms	1.68 ms	843 μs	493 μs	210 μs
PRBS 2 ²³ -1	3.45 s	863 ms	429 ms	216 ms	126 ms	53.7 ms
PRBS 2 ³¹ -1	884 s	221 s	110 s	55.2 s	32.3 s	13.7 s



CAUTION

- The impedance of the Sync Out connector is 50 Ω. Measurement may not be performed correctly if a coaxial cable with another impedance is used or if the impedance of the DUT is not 50 Ω.
- The output voltage of the Sync Out connector is -0.5 to 0 V. Check that the output voltage does not exceed the DUT maximum input specifications. If it does, connect an attenuator to the Sync Out connector.

The signal types that can be selected will vary depending on the dividing ratio displayed in the PPG/ED Bit Rate setting. Sync Output combinations that can be selected depending on dividing ratio are shown in the following table. For PPG Ch2 and ED Ch2, Ch3, Ch4, replace PPG1 in the table with PPG2, and ED1 with ED2, ED3, and ED4.

Table 5.8-2 PPG/ED Ch1 Sync Output Combinations (Synchronous with PPG)

PPG Divide Rate	Signal Type					
	PPG1_1/1 Clk	PPG1_1/2 Clk	PPG1_1/4 Clk	PPG1_1/8 Clk	PPG1_1/16 Clk	PPG1_1/64 Clk
1/1	–	–	✓	✓	✓	✓
1/2	–	✓	✓	–	✓	–
1/4	✓	✓	–	–	✓	–
1/8	✓	–	–	–	–	–
1/16	✓	–	–	–	–	–
1/32	✓	–	–	–	–	–
1/64	✓	–	–	–	–	–

✓: Can be set
 –: Cannot be set

Table 5.8-3 Combination of Signals Set to Sync Output (Synchronous with ED)

ED Divide Rate	Signal Type		
	ED1_1/4 Clk	ED1_1/8 Clk	ED1_1/16 Clk
1/1	–	✓	✓
1/2	✓	–	✓

✓: Can be set
 –: Cannot be set

Note:

PPG Pattern Sync cannot be set for the following EYE/Pulse Scope settings.

Time dialog box

Data Clock Rate: Tracking On

Procedures

1. Touch [Sync Output].
2. Select the signal type to be output to Sync Output.

Chapter 6 *Measuring Bit Error*

This chapter explains how to set the interface of the ED and the measurement conditions and the conditions of the error detection for measuring the bit error rate.

6.1	Function List.....	6-2
6.2	Procedure of Measuring Bit Error Rate	6-9
6.3	Setting Conditions for Error Detection	6-10
6.4	Setting Measurement Conditions.....	6-21
6.5	Measurement Result.....	6-24
6.6	Saving Measurement Results.....	6-25

6.1 Function List

The bit error rate can be measured at the Error Detector (ED).
The ED has the following functions.

Table 6.1-1 Items Set at ED

Item	Description
Tracking	Sets test pattern setting at PPG.
Data Input Condition	Sets connector used for inputting signal.
Threshold (Data Input Condition)	Sets threshold voltage for evaluating “0” and “1” at Data In and Data In connectors. The setting voltage range varies depending on the value of the External Attenuator Factor.
External ATT	When inserting attenuator at connector, that attenuation is entered.
Test Pattern	Selects PRBS or Programmable Pattern.
POS/NEG	Sets the signal level of the Data connector responding to Pattern 1.
Programmable Pattern	Selects the pattern file name to be used when Test Pattern is set to Programmable Pattern. The file name selected is displayed.
Data Length	Displays pattern length in bit units.
Auto SYNC	Sets whether or not to execute resynchronization processing when pattern sync lost
Threshold (Auto SYNC)	When Auto SYNC is On, sets bit error rate judging pattern sync loss.
SYNC Control	When the pattern is Programmable Pattern, set the synchronization method.
Frame Position	At Programmable Pattern, sets bit string header position used in sync frame.
ED Result	Sets the method for displaying the bit error measurement results.
History Reset	Deletes history of warning display.
Gating Cycle	Sets single measurement, repeat measurement or continuous measurement.
Measurement Cycle	Sets the measurement time.
Current	Setting to [On] updates the results display while measurement is in progress. Setting to [Off] updates the results display after the measurement cycle has elapsed.
Start/Stop	Stops/starts bit error rate measurement.

Table 6.1-1 Items Set at ED (Cont'd)

Item	Description
Bit Rate Standard	Displays the communication specifications applying to transmission rate.
Bit Rate	Displays the bit rate. This is always the same as the bit rate set for the PPG.
Data Length	Displays the pattern length as bits.
ER	Bit error rate
EC	Bit error count
INS	Insertion error: Error count and error rate for "1" instead of correct "0"
OMS	Omission error: Error count and error rate for "0" instead of correct "1"
Total	Sum of Insertion error and Omission error
CC	Clock count
FREQ (kHz)	Frequency (kHz)
Warning Display	Displays an alarm if data could not be detected, if pattern could not be synchronized, or a bit error was detected. SYNC Loss: Pattern Synchronization Loss Error: Bit Error
History Display	Lights in red when the red Warning Display goes out.
Measurement Progress	Displays the measurement progress in %.

To display the ED setting screen

1. Touch [PPG/ED Ch1], [PPG/ED Ch2], [PPG/ED Ch3], or [PPG/ED Ch4] at the function menu.
2. Touch [ED] to display the screen as shown in Figure 6.1-1.
3. Touch [Main] to display the screen as shown in Figure 6.1-2.
4. Touch [Expand] to change the screen as shown in Figure 6.1-1.

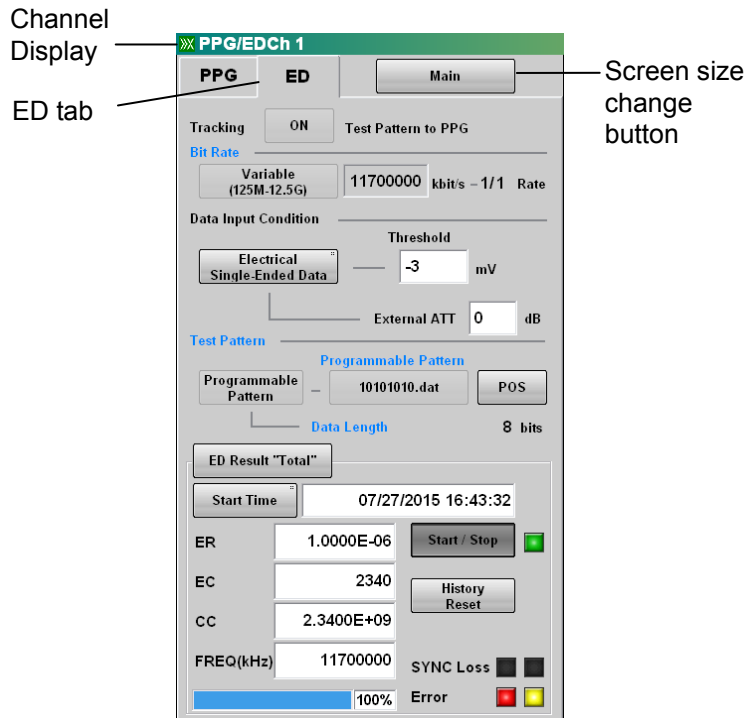

Figure 6.1-1 ED Setting Panel

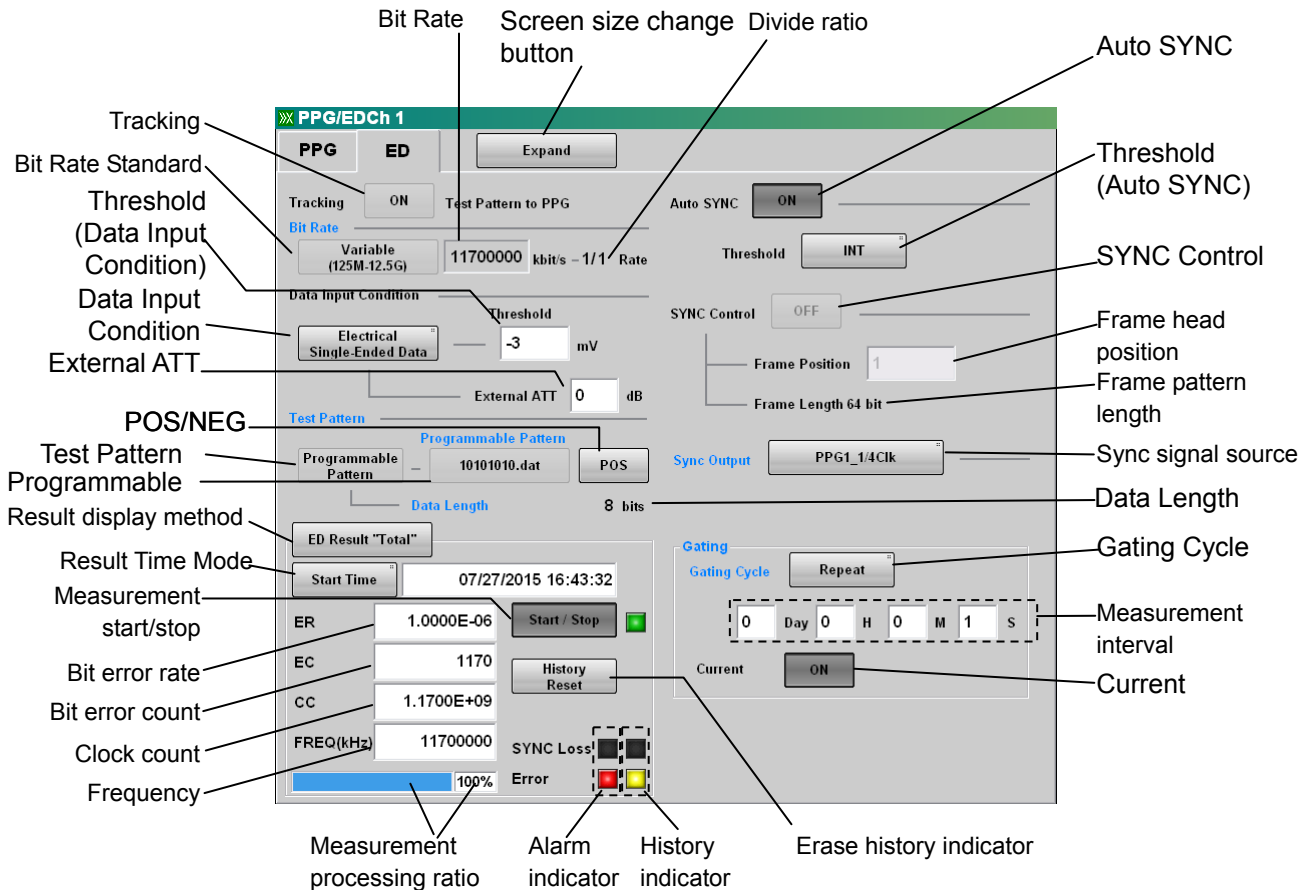

Figure 6.1-2 ED Setting Panel (Details)

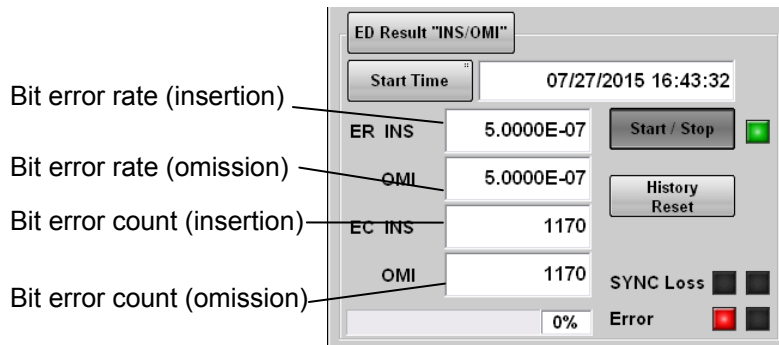

Figure 6.1-3 ED Panel Result Display 2

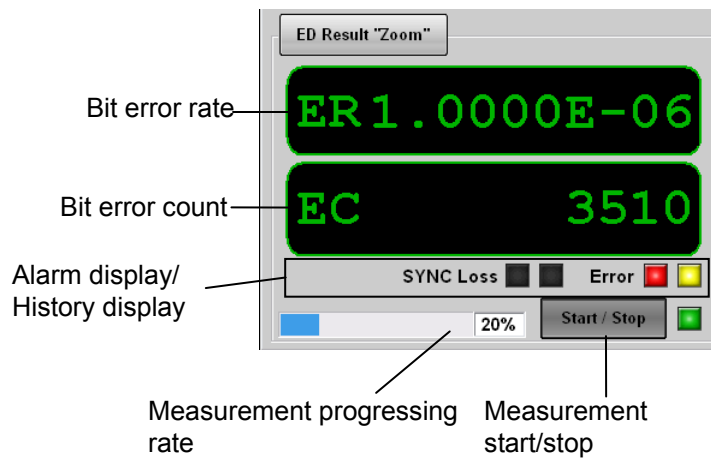

Figure 6.1-4 ED Panel Result Display 3

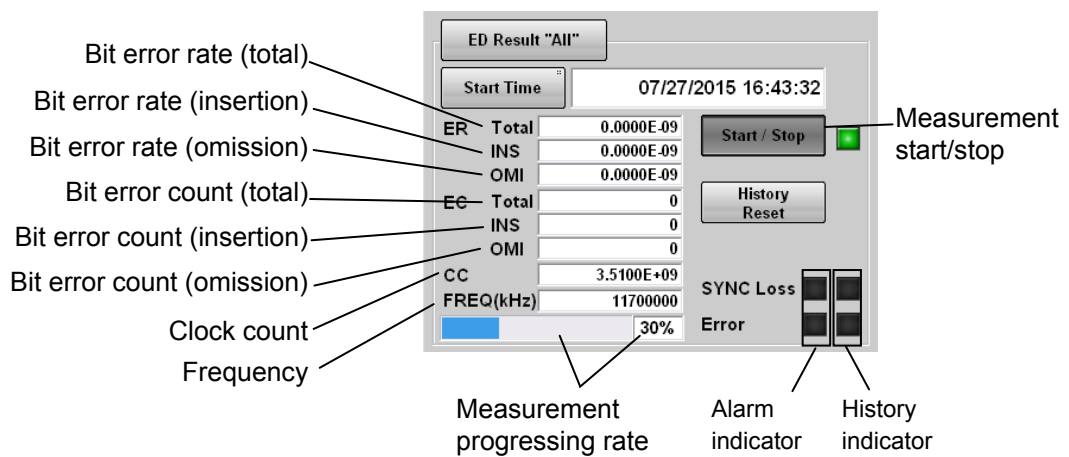

Figure 6.1-5 ED Panel Result Display 4

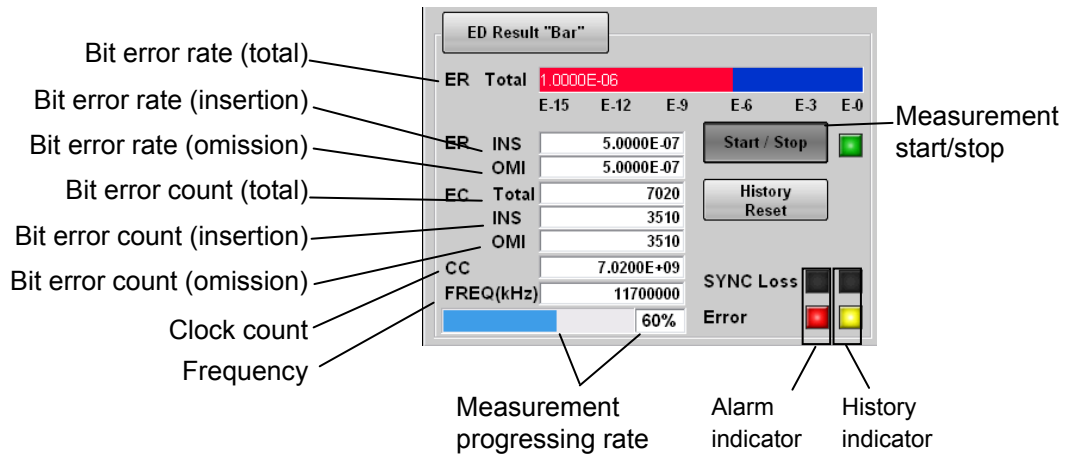

Figure 6.1-6 ED Panel Result Display 5

The setting range of the ED is as follows:

Auto Sync

Off

On

Threshold

INT

1E-2

1E-3

1E-4

1E-5

1E-6

1E-7

1E-8

Bit Rate

Variable

1250 000 to 12 500 000 kbit/s*1

1GFC*2

2GFC*2

4GFC

8GFC

10GFC

10G-FC-FEC

1GbE*2

2GbE*2

CPRI*2

CPRI-2*2

CPRI-4*2

CPRI-5*2

CPRI-10*2
 Infiniband*2
 Infiniband×2
 Infiniband×4
 10GbE WAN
 10GbE LAN/PHY
 10GbE OTU1e
 10GbE OTU2e
 OBSAIRP3*2
 OBSAIRP3×2*2
 OBSAIRP3×4*2
 OC-3/STM-1*2
 OC-12/STM-4*2
 OC-24*2
 OC-48/STM-16*2
 OTU-1*2
 OC-192/STM-64
 G.975 FEC
 OTU-2

Data Input Condition

- Differential 50 Ohm
- Electrical Single-Ended Data
- Electrical Single-Ended XData
- Threshold
 - 85 to 85 mV (External Attenuator Factor = 0 dB)
- External Attenuation
 - 0 to 30 dB

ED Result

- All
- INS/OMI
- Total
- Zoom

Gating

- Current
 - Off
 - On
- Gating Cycle
 - Repeat
 - 1 second to 9 day 23 hour 59 minute 59 second
 - Single
 - 1 second to 9 day 23 hour 59 minute 59 second
 - Untimed

Result Time

- Elapsed Time

Remaining Time
Start Time
SYNC Control
Off
On
Frame Position
1 to Data Pattern Length-64
Test Pattern
PRBS2⁷⁻¹
PRBS2⁹⁻¹
PRBS2¹⁵⁻¹
PRBS2²³⁻¹
PRBS2³¹⁻¹
Programmable Pattern
Programmable Pattern
POS/NEG
NEG
POS
Tracking
Off
On

*1: Refer to Table 5.5-1 for the setting ranges when the Option 092 is not installed.

*2: When installing the Option 092

6.2 Procedure of Measuring Bit Error Rate

The following figure shows the basic procedure for measuring the bit error rate.

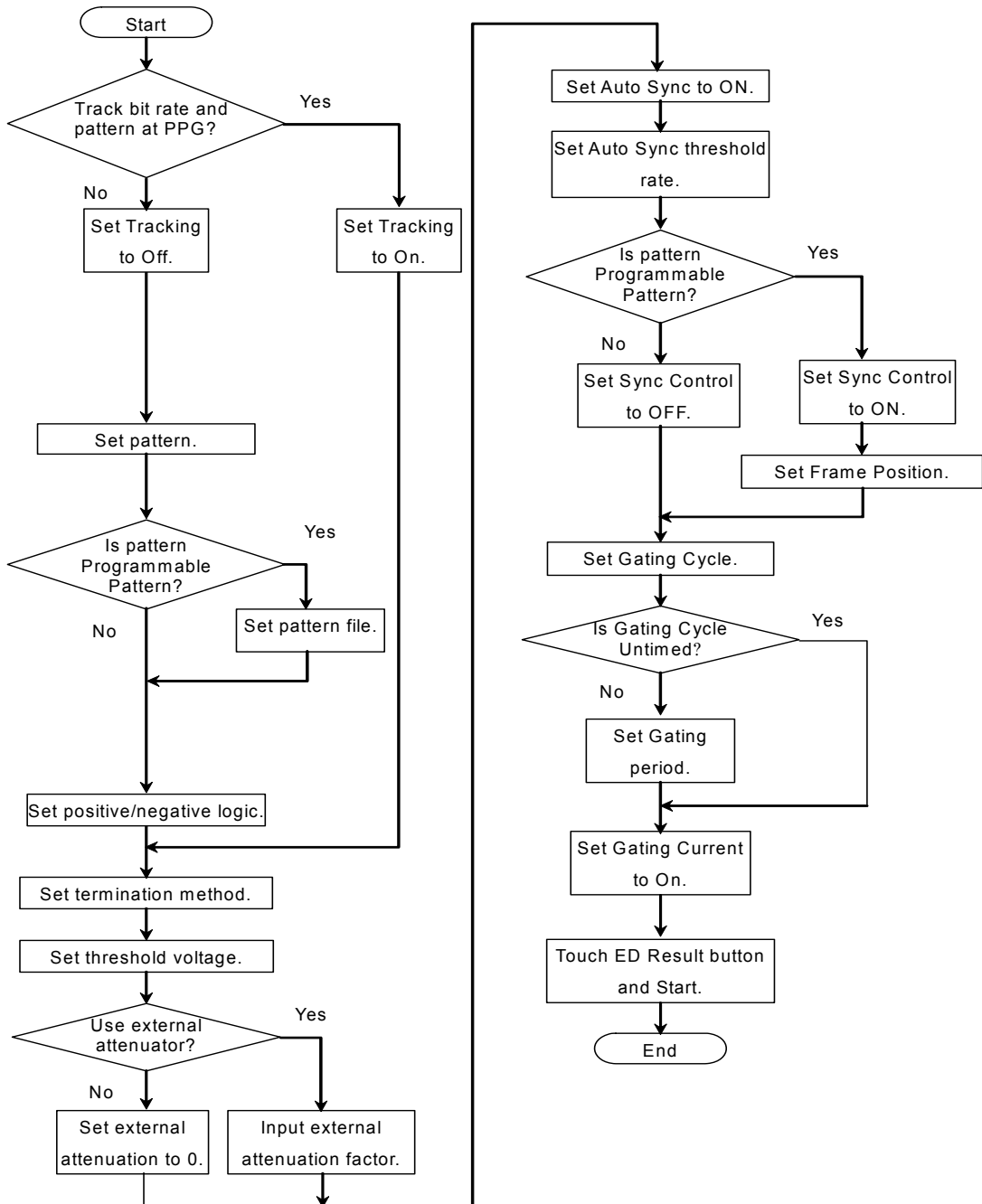

Figure 6.2-1 Basic Procedure of Bit Error Rate Measurement

6.3 Setting Conditions for Error Detection

The conditions for detecting bit errors must be set.

Signal input terminal

The signal input terminals for the ED are the ED1, ED2, ED3, and ED4 $\overline{\text{Data}}$ In connectors and Data In connector on the panel.

The ED1 connector supports ED_Ch1 and the ED2 connector supports ED_Ch2.

The ED1 connector corresponds to ED_Ch1, and the ED2 connector corresponds to ED_Ch2.

The ED1, ED2, ED3, and ED4 signal input terminals are AC couplings.

The block diagram for input terminal is as shown below.

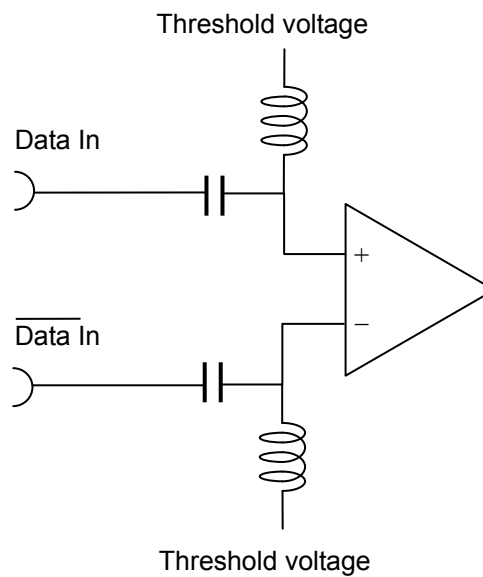

Figure 6.3-1 Input Terminal Block Diagram

CAUTION

- The impedance of the electrical input connector is 50 Ω . Measurement may not be performed correctly if a coaxial cable with another impedance is used.
 - Do not apply a DC voltage of more than 1 V to the $\overline{\text{Data}}$ In connectors. Otherwise, the internal circuits may be damaged.
-

Select the signal input terminal depending on the Data Input Condition [Differential 50 Ohm]: Signal input terminal for both Data In and $\overline{\text{Data}}$ In connectors. The differential voltage of each signal input to two connectors is the input voltage.

[Electrical Single-Ended Data]:

Signal input terminal for Data In connector

[Electrical Single-Ended XData]:

Signal input terminal for $\overline{\text{Data}}$ In connector

Attenuator Factor (External Attenuation)

When installing the fixed attenuator in the Data In and $\overline{\text{Data}}$ In connectors of the BERTWave, input the attenuation (dB) of the fixed attenuator.

The threshold voltage calculated to the input voltage of the attenuator is displayed.

The calculation formula is as follows:

$$\text{Calculated Threshold Voltage} = \text{Threshold Voltage} \times 10^{(\text{attenuation}/20)}$$

Threshold Level

Voltage level for evaluating “1” and “0”.

The input terminals are AC coupled, so set a voltage corresponding to the signal waveform excluding the DC components.

The following figure shows the waveform input to the connector and the waveform excluding DC components when the input signal level is LVPECL.

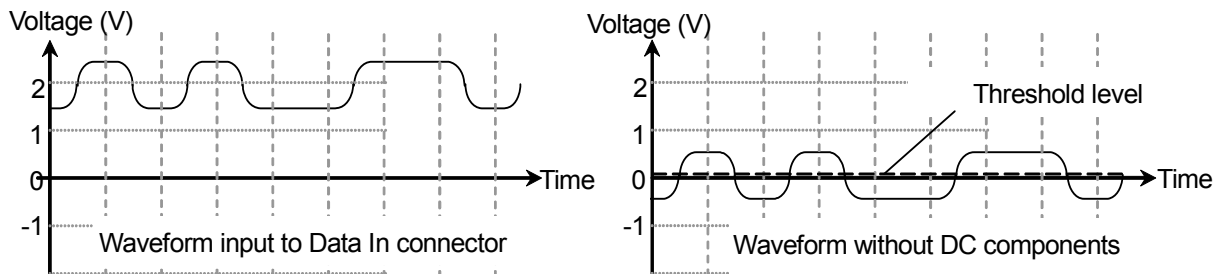

Figure 6.3-2 Eye Pattern Monitoring

Logic

Select the positive logic (POS) or negative logic (NEG).

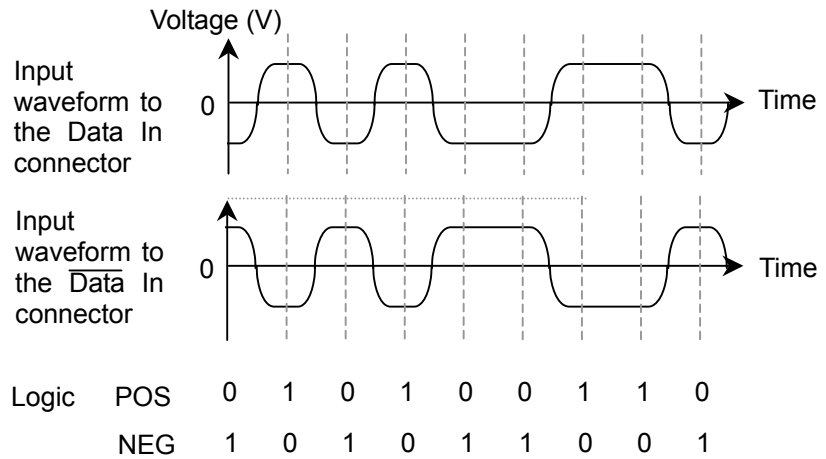

Figure 6.3-3 Values Defined as Input Waveform

Pattern

The ED compares the received bit string and the internally generated bit stream bit-by-bit and evaluates it differences as it errors.

As a result, set the same pattern at the PPG and ED.

For PRBS, since it is possible to predict the bits received next from the received bit string, the time required for pattern synchronization can be much shorter than for a Programmable Pattern.

There are two synchronization methods depending on the pattern length for Programmable Pattern.

SYNC Control: OFF The entire pattern bits and received bit string are compared.

SYNC Control: ON When the pattern length is 128 bits or more, 64 bits starting from the bit specified at Frame Position and the received bit string are compared. When all 64 bits are in agreement, the data from bit 65 is compared. When the pattern length is 127 bits or less, the entire received bit string and data are compared.

All data bits are compared and when the obtained bit error rate is lower than the bit error rate is set at Auto Sync Threshold, pattern synchronization is evaluated as having been obtained.

To shorten the pattern sync time when SYNC Control is ON, set the value of the 64-bit string which is not duplicate in other portion in the same string to Frame Position in programmable pattern. The pattern synchronization takes much time if there are multiple 64-bit strings, which is the same as 64-bit string used for the same string synchronization detection.

	+0	+1	+2	+3	+4	+5	+6	+7	+8	+9	+A	+B	+C	+D	+E	+F
000000	55	55	55	55	55	55	55	55	55	55	55	55	55	55	55	55
000010	55	55	55	55	55	55	55	55	55	55	55	55	55	55	55	55
000020	55	55	55	55	55	55	55	55	55	55	55	55	55	55	55	55
000030	55	55	55	55	55	55	55	55	55	55	55	55	55	55	55	55
000040	00	01	02	03	04	05	06	07	08	09	0A	0B	0C	0D	0E	0F
000050	10	11	12	13	14	15	16	17	18	19	1A	1B	1C	1D	1E	1F
000060	20	21	22	23	24	25	26	27	28	29	2A	2B	2C	2D	2E	2F
000070	30	31	32	33	34	35	36	37	38	39	3A	3B	3C	3D	3E	3F
000080	40	41	42	43	44	45	46	47	48	49	4A	4B	4C	4D	4E	4F
000090	50	51	52	53	54	55	56	57	58	59	5A	5B	5C	5D	5E	5F
0000A0	60	61	62	63	64	65	66	67	68	69	6A	6B	6C	6D	6E	6F
0000B0	70	71	72	73	74	75	76	77	78	79	7A	7B	7C	7D	7E	7F

Figure 6.3-4 Programmable Pattern Example 1

Figure 6.3-5 shows an example of programmable pattern when pattern length is 1536 bits.

In this example, 64 bytes from the programmable pattern header have the same value of 0x55, so the header 512 bits is a repeating pattern of alternating 1s and 0s.

When Frame Position is set to 1 in this programmable pattern, the 8 bytes of data from address 0x000000 to address 0x000007 are used to detect pattern synchronization.

There are 224 points between address 0x000000 and address 0x000038 with these 8 bytes match. The data remaining after these 8 byte data matches is compared and the proportion of matched bits in the entire programmable pattern is 1:224. When pattern synchronization processing is performed with this type of pattern, the time required to obtain synchronization becomes longer.

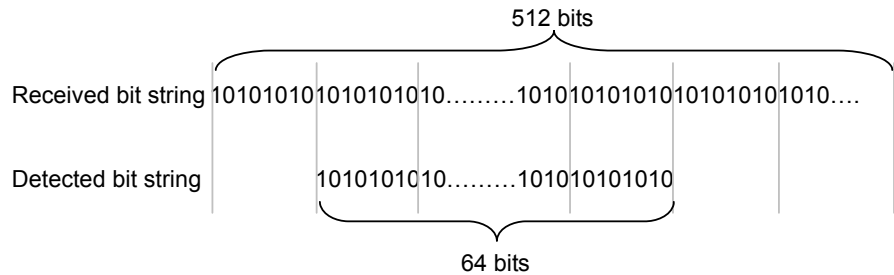

Figure 6.3-5 Pattern Detection Bit String when Frame Position is 1

The bit string used at pattern synchronization must occur at least once within the programmable pattern.

In the example in Figure 6.3-5, when the Frame Position is 513, the bit string between addresses 0x000040 and 0x000047 is used to detect pattern synchronization. This 8-byte bit string appears once in the programmable pattern. As a result, if these 64 bits and the received bit string match, pattern synchronization is obtained.

If there is no bit string appearing at least once in the programmable pattern, the bit string appearing the least number of times is set at Frame Position.

	+0	+1	+2	+3	+4	+5	+6	+7	+8	+9	+A	+B	+C	+D	+E	+F
000000	00	01	02	03	04	05	06	07	08	09	0A	0B	0C	0D	0E	0F
000010	10	11	12	13	14	15	16	17	18	19	1A	1B	1C	1D	1E	1F
000020	20	21	22	23	24	25	26	27	28	29	2A	2B	2C	2D	2E	2F
000030	30	31	32	33	34	35	36	37	38	39	3A	3B	3C	3D	3E	3F
000040	40	41	42	43	44	45	46	47	48	49	4A	4B	4C	4D	4E	4F
000050	50	51	52	53	54	55	56	57	58	59	5A	5B	5C	5D	5E	5F
000060	60	61	62	63	64	65	66	67	68	69	6A	6B	6C	6D	6E	6F
000070	70	71	72	73	74	75	76	77	78	79	7A	7B	7C	7D	7E	7F
000080	00	01	02	03	04	05	06	07	08	09	0A	0B	0C	0D	0E	0F
000090	10	11	12	13	14	15	16	17	18	19	1A	1B	1C	1D	1E	1F
0000A0	20	21	22	23	24	25	26	27	28	29	2A	2B	2C	2D	2E	2F
0000B0	30	31	32	33	34	35	36	37	38	39	3A	3B	3C	3D	3E	3F
0000C0	40	41	42	43	44	45	46	47	48	49	4A	4B	4C	4D	4E	4F
0000E0	50	51	52	53	54	55	56	57	58	59	5A	5B	5C	5D	5E	5F
0000E0	60	61	62	63	64	65	66	67	68	69	6A	6B	6C	6D	6E	6F
0000F0	70	71	72	73	74	75	76	77	78	79	7A	7B	7C	7D	7E	7E

Figure 6.3-6 Programmable Pattern Example 2

Sometimes pattern synchronization is obtained at the wrong position depending on the user data pattern.

An example is shown in Figure 6.3-7. There is just one bit different between data addresses 0x000000 to 0x00007F and addresses 0x000080 to 0x0000FF.

When Frame Position is set to 1 at this programmable pattern, the 8 bytes of data from address 0x000000 to 0x000007 are used to detect pattern synchronization.

The matches for these data bytes are between received bit string addresses 0x000000 and 0x000007, and addresses 0x000080 and 0x000087. There is no bit error in the former but there is one bit error at bit 1024 in the latter. In this case, the bit error rate is 9.77×10^{-4} .

When the bit error rate (Sync Threshold) used to evaluate pattern synchronization is set to 10^{-3} , since the generated bit error rate is lower than this value, the BERTWave evaluates pattern synchronization has been achieved.

To prevent obtaining pattern synchronization at the incorrect position like this, the Sync Threshold bit error rate must be smaller than the reciprocal number of the programmable pattern length. For example, when the pattern length is 16,384 bits, Sync Threshold should be $1E-5$. The maximum Programmable Pattern length is 1305600 bits. When the file data length is over 1305600 bits, the first 1305600 bits are used for the test pattern.

Pattern Sync

Auto SYNC sets the pattern sync method.

[On]: If the bit error rate set at Sync Threshold is exceeded, patterns synchronization is evaluated as lost and synchronization processing is performed.

[Off]: Pattern synchronization processing is not performed.

Set Auto Sync to [On] at measurement start.

After pattern synchronization processing, if there are bit errors exceeding the bit error rate set at Sync Threshold, leave pattern synchronization processing set to [On].

After pattern synchronization processing, even if there are bit errors exceeding the bit error rate set as Sync Threshold, set to [Off] when not processing the pattern synchronization.

Bit error rate for executing pattern synchronization processing

Auto SYNC Threshold sets the bit error rate for starting or stopping pattern synchronization processing.

The bit error rate for starting pattern synchronization processing (sync processing start level) must be set to a larger value than the bit error rate for stopping pattern sync processing (sync processing stop level). This offers a method for starting/stopping pattern sync processing using hysteresis.

The following figure shows the sync processing start and stop levels when 1E-2 are selected at Sync Threshold.

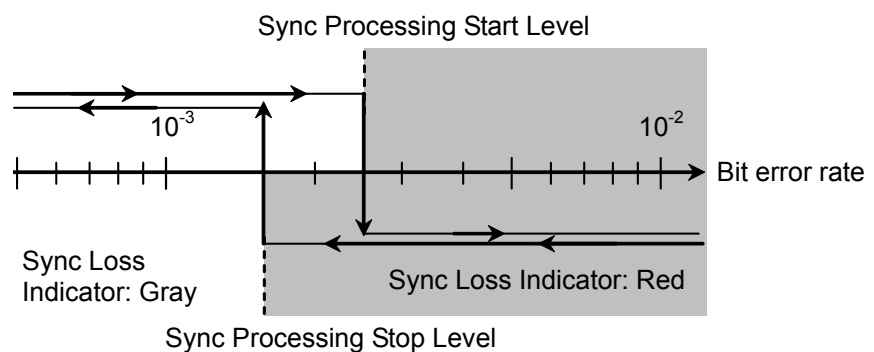

Figure 6.3-7 Bit Error Rate at Pattern Sync Processing Start/Stop Level

When selecting [INT], the bit error rates vary depending on the Test Pattern types, pattern length and Sync control settings.

The following table shows the sync processing start and stop levels for each Sync Threshold selection.

Table 6.3-1 Bit Error Rate when Threshold setting is INT

Test Pattern	Sync Control	Pattern Length	Bit Error Rate	
			Sync Processing Start Level	Sync Processing Stop Level
PRBS	–	2^{n-1} (n=7,9,15,23,31)	2.5×10^{-2}	1.56×10^{-2}
Programmable Pattern	OFF	2 to 16	2.5×10^{-2}	1.56×10^{-2}
		17 to 160	5.0×10^{-3}	1.56×10^{-3}
		161 to 1,600	5.0×10^{-4}	1.56×10^{-4}
		1,601 to 16,000	5.0×10^{-5}	1.56×10^{-5}
		16,001 to 80,000	1.0×10^{-5}	6.25×10^{-6}
		80,001 to 160,000	5.0×10^{-6}	3.13×10^{-6}
		160,001 to 320,000	2.5×10^{-6}	1.56×10^{-6}
		320,001 to 524,288	1.9×10^{-6}	7.81×10^{-7}
	524,289 to 1,048,576	9.54×10^{-7}	3.91×10^{-7}	
	ON	128 to 5,120	1.95×10^{-4}	1.56×10^{-4}
		5,121 to 10,240	9.77×10^{-5}	7.81×10^{-4}
		10,241 to 51,200	1.95×10^{-5}	1.56×10^{-5}
		51,201 to 102,400	9.77×10^{-6}	7.81×10^{-5}
		102,401 to 204,800	4.88×10^{-6}	3.91×10^{-6}
		204,801 to 307,200	3.26×10^{-6}	2.60×10^{-6}
		307,201 to 409,600	2.44×10^{-6}	1.95×10^{-6}
409,601 to 524,288		1.91×10^{-6}	1.53×10^{-6}	
524,289 to 1,048,576	9.54×10^{-7}	7.63×10^{-7}		

Table 6.3-2 Threshold Settings and Bit Error Rate (at 1E-2 to 1E-8)

Sync Threshold	Bit Error Rate	
	Sync Processing Start Level	Sync Processing Stop Level
1E-2	2.5×10^{-2}	1.56×10^{-2}
1E-3	2.5×10^{-3}	1.56×10^{-3}
1E-4	2.5×10^{-4}	1.56×10^{-4}
1E-5	2.5×10^{-5}	1.56×10^{-5}
1E-6	2.5×10^{-6}	1.56×10^{-6}
1E-7	2.5×10^{-7}	1.56×10^{-7}
1E-8	2.5×10^{-8}	1.56×10^{-8}

The setting procedure of the error detection conditions is as follows:

1. When changing the bit rate and pattern of the PPG and applying the changing settings to the ED touch the Tracking button and set to [On].

When setting to [On], go to the step 6.

When setting to [Off], go to the step 2.

2. Touch the Bit Rate button and select the standard.
Set the same standard of the PPG.
3. Touch the Test Pattern button and select the pattern.
Set the same pattern of the PPG.
4. Set Logic to [POS] or [NEG].
5. Touch the Data Input Condition button.
6. Select the connector receiving the signal from the followings:

[Differential 50 Ohm]:	Data In and $\overline{\text{Data}}$ In connectors
[Electrical Single-Ended Data]:	Data In connector
[Electrical Single-Ended XData]:	$\overline{\text{Data}}$ In connector
7. Touch the External ATT test box.
8. When inserting the fixed attenuator to the $\overline{\text{Data}}$ In and Data In connectors, enter the attenuation (dB). When not inserting the attenuator, enter 0.
9. Touch the Threshold text box.
10. Enter the threshold voltage.

When Test Pattern is set to Programmable Pattern, follow the procedure below.

11. Touch the Programmable Pattern button and open the file dialog box.
12. Select the same file as that of the Programmable Pattern of the PPG.
13. Touch the Frame Position text box.
14. Enter the frame head position.

 **CAUTION**

- **When attenuators are connected to both the Data In and Data In connectors, use attenuators with the same attenuation. If the amount of attenuation is different, the displayed threshold voltage and the actual threshold voltage may be different.**
 - **If the input voltage to the attenuators is either more than 5 V or less than -5 V, check that the power consumed by the attenuators does not exceed the rated power.**
 - **Check that the voltage of the signal attenuated by the attenuators does not exceed the voltage displayed at the Data In and Data In connectors.**
-

6.4 Setting Measurement Conditions

To set how to measure bit error:

Set Gating Cycle at Gating.

- [Single]: Performs measurement until the time set at the measurement period is exceeded.
- [Repeat]: Performs measurement until ER Result button display becomes [Stop].
The bit error rate returns to 0 at each measurement period.
- [Untimed]: Performs measurement until ER Result button display becomes [Stop]. The bit errors are accumulated.

The following figure shows the relationship between the Gating Cycle setting and the change in the displayed bit error count.

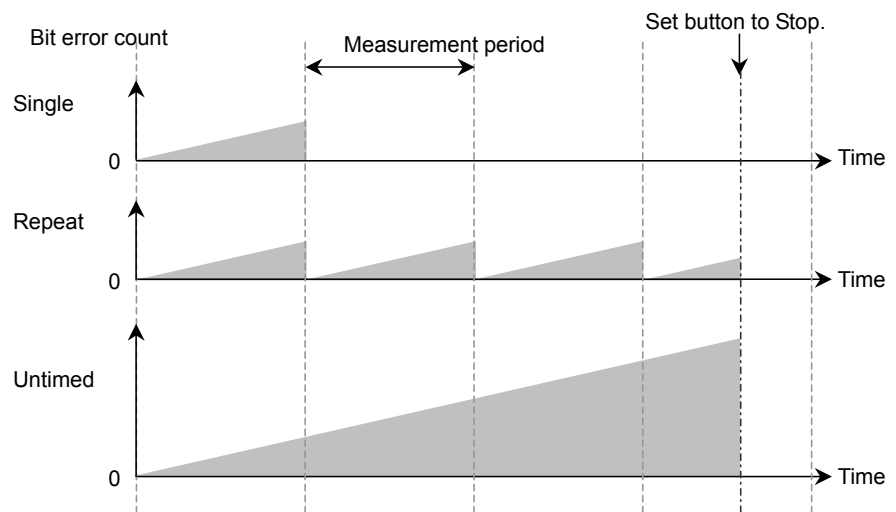

Figure 6.4-1 Gating Cycle Settings and Bit Error Count

Bit error measurement Period

The Gating Period can be set when Gating Cycle is Single or Repeat. The time can be set from 1 second to 9 days 23 hours 59 minutes 59 seconds.

Measurement method

The ED Result display can be refreshed either in real time (approx. 1 s intervals) or when the progress bar reaches 100%. The display method is set at Current of Gating.

[On]: Updates measurement results in real time.

[Off]: Updates measurement results when progress reaches 100% for either Single or Repeat Gating Cycle.

Updates measurement results when measurement stops for Untimed Gating Cycle.

The setting procedure of the measurement conditions is as follows:

1. Touch the Gating Cycle button and select the measurement method as follows:
[Repeat]
[Single]
[Untimed]
2. When Gating Cycle is Repeat or Single, touch the text box under the Gating Cycle and enter the numeric value.
The measurement cycle can be set from 1 second to 9 days 23 hours 59 minutes 59 seconds.
3. Touch [Current] to set the timing for the measurement result.
[On]: Updates measurement results per 100 ms.
[Off]: Displays measurement results per measurement results or when measurement stops
4. Touch the measurement start/stop button, and set the display to [Start].
The right indicator of the button is changed to green.
Measure is displayed at the status display.
The measurement processing rate is displayed.

When pattern synchronization is obtained, the SYNC Loss display is erased.

When Gating Cycle is set to [Untimed], the measurement cycle progress is displayed every 5 seconds.

When SYNC Loss is displayed in red

Pattern synchronization has not been obtained; check the following:

- The Test Pattern generated by the DUT matches the Test Pattern for the error detector.
- The Logic POS and NEG settings are correct.
- A suitable threshold voltage has been set for the signal input to the Data In connector and the $\overline{\text{Data}}$ In connector.

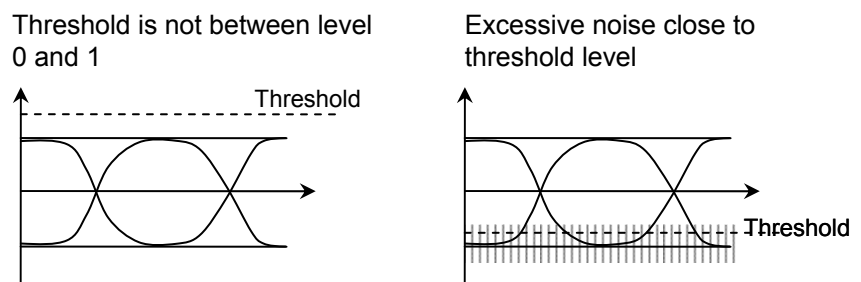

Figure 6.4-2 Examples of Improper Thresholds

6.5 Measurement Result

The following measurement result is displayed in the ED Result.

Start Time: Time when bit error measurement started

Elapsed Time: Time elapsed from start of bit error rate measurement
When Gating Cycle is Single or Repeat, when time exceeds the Time setting at Gating, the time is reset back to 0.

Remaining Time: Bit error measurement elapsed time subtracted from time set at Gating Time setting.

ER: The bit error rate is displayed from 0.0001E-18 to 1.0000E-0.

Mantissa is 0.0000 when the bit error does not occur.

At this time, the numeric part varies depending on the clock number.

Example: 0.0000E-3 Clock count 1000 or more, 9999 or less

0.0000E-4 Clock count 10000 or more, 99999 or less

EC: The occurred bit errors are displayed from 0 to 9999999 or from 1.0000E07 to 9.9999E17.

CC: The received bit count is displayed from 0 to 9999999 or from 1.0000E07 to 9.9999E17.

FREQ (kHz): Clock frequency calculated by the received bit count.

It is the same as the transmission speed (kbit/s) of the received data.

Alarm Indicator

Error: Displays red when detecting bit error.

SYNC Loss: Displays red when pattern not synchronized.

When the alarm indicator goes red once, the History Indicator goes yellow when the cause of the alarm is removed, indicating that an alarm occurred.

When the [History Reset] button is pressed when the History Indicator is yellow, the yellow display disappears.

6.6 Saving Measurement Results

The measurement result of the saved bit error is as follows:

Bit Error Measurement Result

CC (Clock Count)

EC (Error Count)

ER (Error Rate)

Frequency

Start Time

Stop Time

Test Pattern

```

Anritsu;MP2100B      ;01.00;TXT-----
Pattern PRBS2^23-1
Option  14,23,92,52
Start   2015/06/04 17:48:24      End   2015/06/04 17:57:31

      | Total          INS          OMI
-----+-----
ER    | 2.0000E-08  8.0000E-02  1.2000E-0
EC    | 1.0000E+09  4.0000E+08  6.0000E+08

Frequency      Clock Count
-----
10312500kHz    6.1875E+11

```

Figure 6.6-1 Text File Example

```
Anritsu;MP2100B;01.00;CSV
Pattern,PRBS2^23-1
Option 14,23,92,52
Start 2015/06/04 17:48:24      End 2015/06/04 17:57:31

,Total,INS,OMI
ER,0.0000E-11,0.0000E-11,0.0000E-11
EC,0,0.0000E-11,0.0000E-11

Frequency,Clock Count
10312500kHz,6.1875E+11
```

Figure 6.6-2 CSV File Example

Procedure

1. Touch [System Menu].
2. Touch [Save].
3. Select from [All], [PPG/ED Ch1], [PPG/ED Ch2], [PPG/ED Ch3], or [PPG/ED Ch4].
Selecting [All] saves the measurement results for PPG/ED Ch1 to 4.
4. Touch [Result].
The file name input dialog box is displayed.
5. When saving the file as the displayed file name, touch [OK].
6. Touch the right button of the text box when editing the file name.
The software keyboard is displayed.
7. Input the file name.
8. When changing the file name, touch [OK], and when canceling the procedure, touch [Cancel] and go back to the step 4.

The measurement result file is saved in the following folder.

```
C:\Program Files\Anritsu\MP2100A\MX210000A\UserData\Result\CSV
C:\Program Files\Anritsu\MP2100A\MX210000A\UserData\Result\TXT
```

Chapter 7 Measuring Waveform

This chapter explains how to measure waveforms of periodic signal in time.

7.1	EYE/Pulse Scope Screen	7-2
7.1.1	Sampling oscilloscope features	7-2
7.1.2	Description of items on the EYE/Pulse Scope window	7-3
7.2	Setting Item List	7-12
7.3	Restrictions for Setting Parameters	7-22
7.4	Measurement Procedure	7-23
7.5	Calibrating Sampling Oscilloscope	7-24
7.5.1	Calibrating Level	7-24
7.5.2	Performing Self Test	7-26
7.6	Setting Clock Recovery and Rate	7-28
7.6.1	Setting Clock Recovery Unit	7-29
7.6.2	Setting Bit Rate	7-31
7.6.3	Setting Clock Rate and Divide Rate	7-32
7.7	Setting Data Collection Method	7-33
7.8	Setting Pattern Length	7-38
7.9	Collecting Data	7-39
7.10	Adjusting Screen Scale	7-41
7.10.1	Adjusting scale automatically	7-41
7.10.2	Adjusting Vertical-axis of Screen	7-43
7.10.3	Adjusting Horizontal-axis of Screen	7-45
7.10.4	Calibrating attenuation of Adjusting External Attenuator	7-46
7.11	Measuring Waveform	7-47
7.11.1	Amplitude and Time Measurements	7-48
7.11.2	Displaying Histogram	7-54
7.11.3	Executing Mask Test	7-57
7.12	Using Marker	7-66
7.13	Waveform Math Calculation	7-68
7.14	Using Trace Memory	7-69
7.15	Displaying a Label	7-70
7.16	Saving Measurement Results	7-71

7.1 EYE/Pulse Scope Screen

7.1.1 Sampling oscilloscope features

The sampling oscilloscope, measuring the waveform, has the following main features.

- Data collection method
Trigger clock frequency setting, eye mode/pulse mode display, and waveform cumulative display
- Clock Recovery
Frequency bandwidth of clock recover unit and loop filter settings
The clock recovered from the input data is output at the panel CRU Out connector.
- Screen Scale settings
Screen vertical and horizontal axis scales
- Waveform analysis
Measuring Parameters for evaluation of the waveform such as rise time and jitter

7.1.2 Description of items on the EYE/Pulse Scope window

In the function menu, touch [EYE/Pulse Scope], and then the EYE/Pulse Scope result window is displayed.

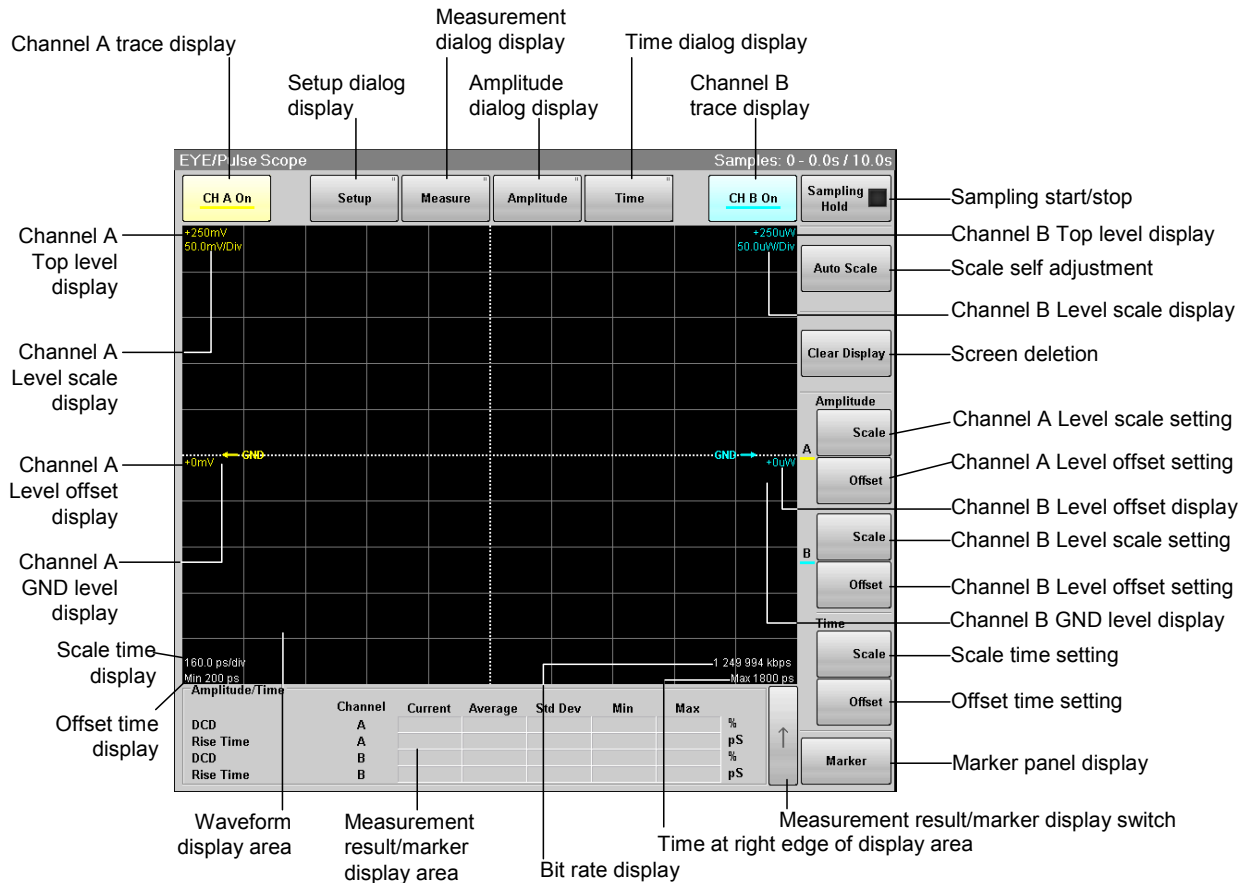

Figure 7.1.2-1 Result Window

Touching [Setup] – [Measure] – [Amplitude] – [Time] displays the dialog box.

Touching [Marker] displays the marker panel.

Setup dialog box

Touch [Setup] shown in Figure 7.1.2-1 to display the Setup dialog box shown in Figure 7.1.2-2.

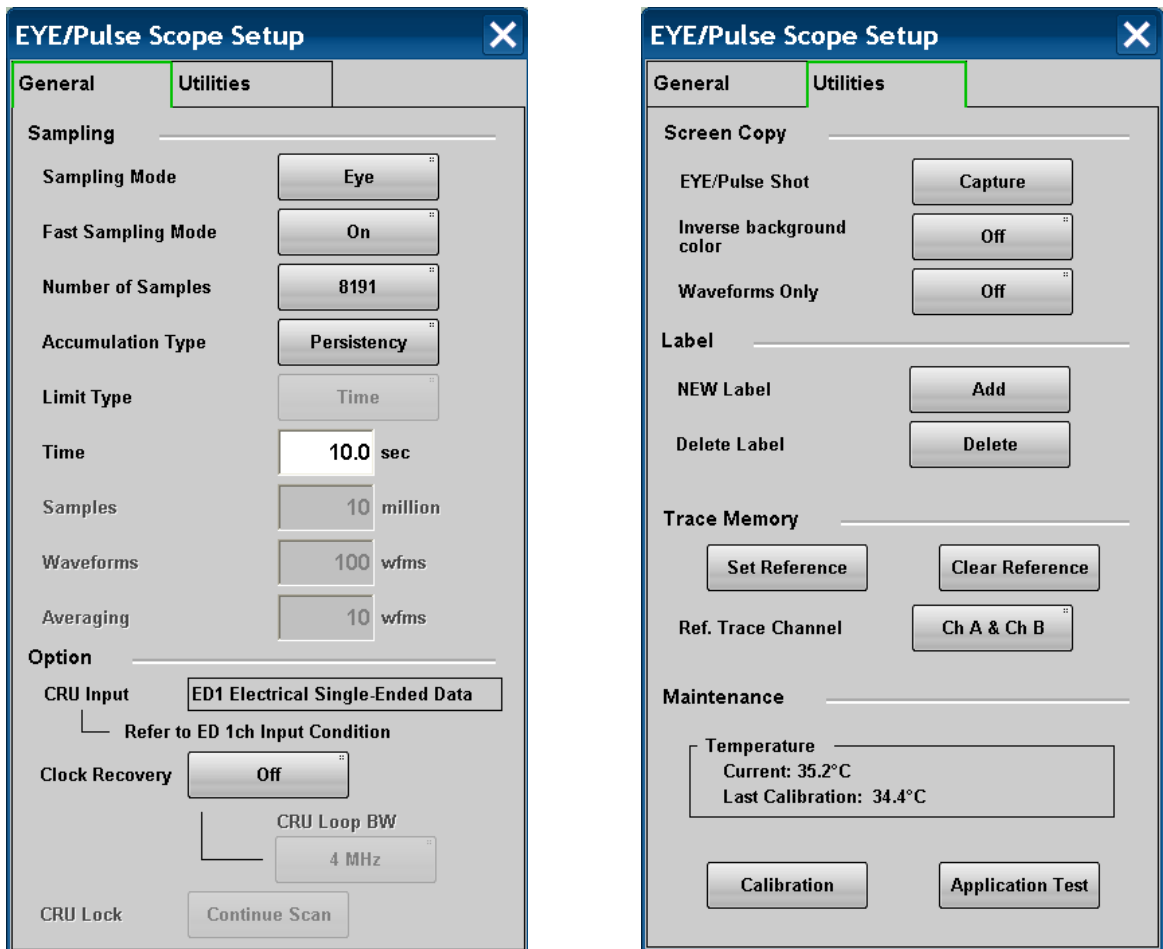

Figure 7.1.2-2 Setup Dialog Box

Tab	Item	Description
General	Sampling Mode	Switches to Eye/Pulse/ Coherent Eye mode.
	Fast Sampling Mode	Increases the eye pattern data sampling speed if set to [On]. This parameter can be set when Sampling Mode is Eye.
	Number of Samples	Sets the number of samples.
	Accumulation Type	Sets the accumulation method of the sampling data.
	Limit Type	Selects the sampling end conditions from time, sampling count, or frequency.
	Time	Sets the sampling time.
	Sample	Sets the number of samples.
	Waveforms	Sets the waveforms.
	Averaging	When measuring the pulse mode, set the averaging process count.
	CRU Input	Displays the clock recovery input connector when the Option 053, 054, or 055 is added. When the Option 055 is added, the details selected for ED1 Data Input Condition are displayed.
	Clock Recovery	Sets the frequency band for clock recovery when the Option 053, 054, or 055 is added. The input connector is set at the Data Input Condition of the ED.
	CRU Loop BW	Sets the bandwidth of the loop filter when Clock Recovery is set to [>8.5G].
	CRU Lock	When the Option 053, 054, or 055 is added, touch [Continue Scan] to detect the clock recovery frequency.
Utilities	EYE/Pulse Shot	Touching [Capture] saves the screen file in the result window.
	Inverse background color	Sets the color of the save screen at EYE/Pulse Shot.
	Waveforms Only	On: Saves only the waveform displayed in the Result window to a file. Off: Saves the whole Result window to a file.
	NEW Label	Adds a new label.
	Delete Label	Deletes the displayed label.
	Set Reference	Saves the displayed waveform as the reference trace.
	Clear Reference	Deletes the reference trace.
	Ref.Trace Channel	Sets the channel saved in the reference trace.
	Temperature	Displays current temperature of the sampling oscilloscope and the temperature when the level is calibrated.
	Calibration	Calibrates the amplitude level of the sampling oscilloscope.
	Application Test	Runs the self test for the sampling oscilloscope.

Measure dialog box

Touch [Measure] as shown in Figure 7.1.2-1 “Result Window” to display the Measure dialog box as shown in Figure 7.1.2-3.

Touch the measure item button (for example, [Off] in Figure 7.1.2-3), and you can select a measurement item in the Measure Item dialog box.

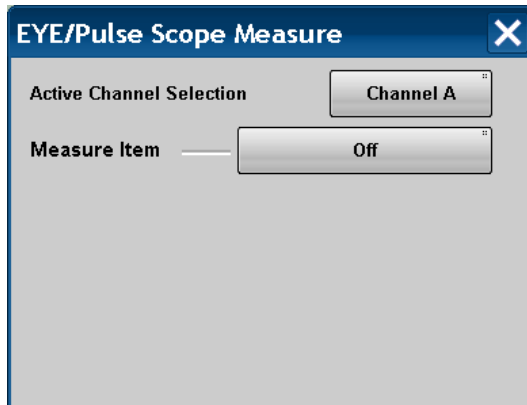

Figure 7.1.2-3 Measure Dialog Box



Figure 7.1.2-4 Measure Item Dialog Box

Item	Description
Active Channel Selection	Selects channel to execute histogram measurement or mask test.
Measure Item	Selects items to be measured.
Off	Sets display of measurement item to Off.
Amplitude/Time	Displays screen to select measurement items for waveform amplitude and time.
Mask Test	Displays screen to set mask test pattern, eye margin, and measurement method.
Histogram	Displays screen to set measurement direction and range of histogram measurement.
Amplitude/Time&Mask	Displays screen to set waveform amplitude/time and measurement method of mask test.
Amplitude/Time&Histogram	Displays screen to set waveform amplitude/time and measurement method of histogram.

For more information about the measurement setting screen, refer to 7.11 “Measuring Waveform”.

Amplitude dialog box

Touch [Amplitude] as shown in Figure 7.1.2-1 “Result Window” to display the Amplitude dialog box as shown in Figure 7.1.2-5.

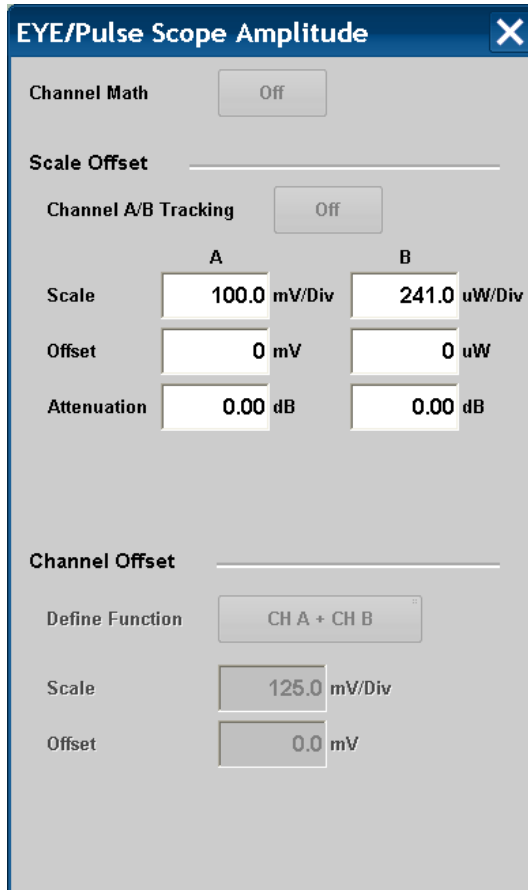

Figure 7.1.2-5 Amplitude Dialog Box (Optical/Single End Electrical Receiver)

Item	Description
Channel Math	[Off]: Displays waveforms for Channel A and B separately. [On]: Calculates waveforms for Channel A and B, and then that calculated result is displayed as Channel A.
Scale Offset	Sets the level scale for Channel A and B.
Channel A/B Tracking	[Off]: Sets scales for Channel A and B separately. [On]: Sets scales for Channel A and B as the same value.
Scale	Sets vertical scale.
Offset	Sets vertical offset.
Attenuation	Sets attenuation amount for external attenuation.
Channel Offset	Sets Channel A and Channel B waveform calculation method and level scale for calculation results waveform.
Define Function	Sets calculation method between channels.
Scale	Sets vertical scale for calculation result between channels.
Offset	Sets vertical offset for calculation result between channels.

Time Dialog Box

Touch [Time] as shown in Figure 7.1.2-1 "Result Window", and then the Time dialog box as shown in Figure 7.1.2-6 is displayed.

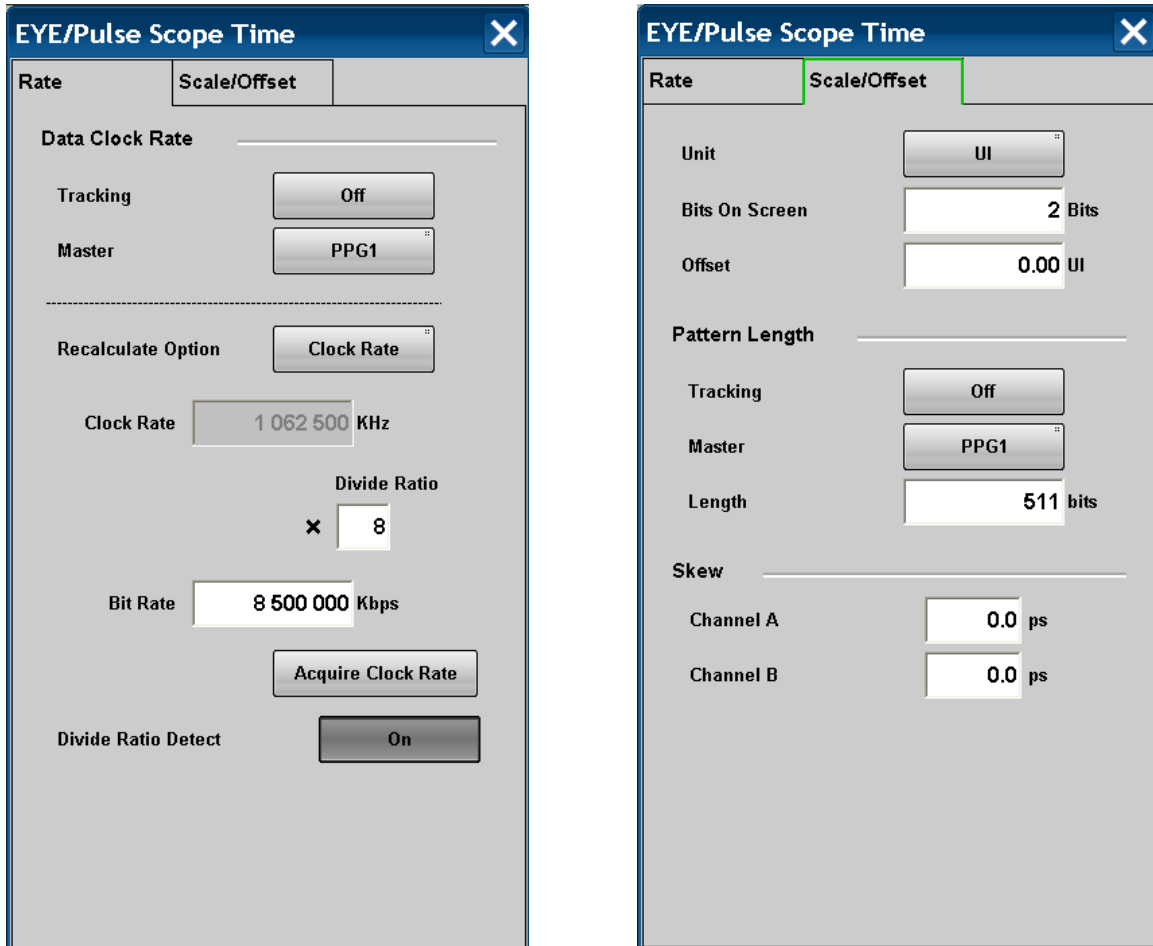

Figure 7.1.2-6 Time Dialog Box

Tab	Item	Description
Rate	Data Clock Rate	Sets input data speed, clock frequency, and frequency dividing rate.
	Tracking	[Off]: Inputs bit rate to Bit Rate [On]: Applies bit rate selected at Master to Bit Rate
	Master	Sets items affecting clock and bit rate.
	Recalculate option	[Clock Rate]: Calculates Clock Rate from Bit Rate and Divide Rate [Bit Rate]: Calculates Bit Rate from Clock Rate and Divide Rate.
	Clock Rate	Sets clock frequency input to Trigger Clk In connector.
	Divide Rate	Sets frequency dividing rate (Bit Rate/Clock Rate).
	Bit Rate	Sets signal bit rate to be measured.
	Acquire Clock Rate	Measures clock frequency input to Trigger Clk In connector.
	Divide Ratio Detect	Sets whether to detect frequency dividing ratio of clock signal input to Trigger Clk In connector.
Scale/Offset	Unit	Sets units of horizontal axis on screen.
	Bits on Screen	Sets bit count of the scale horizontal axis on screen. The range is limited to 1 to 100 when Fast Sampling is On.
	Offset	Sets time on left side of screen.
	Pattern Length	Sets input data pattern length.
	Tracking	[Off]: Allows you to directly set the pattern length in the [Length] box. [On]: Sets pattern length selected at Master to Length.
	Master	Sets items affecting clock and Bit Rate.
	Length	Sets the pattern bit length. When measuring in Pulse mode, this value is used.
	Skew	Sets time offset. Setting positive values moves the waveform to the right. Setting negative values moves the waveform to the left.

7.2 Setting Item List

The setting items are listed below.

- Amplitude
 - Channel Math
 - Off
 - Channel A/B Tracking
 - Off
 - Attenuation
 - A
 - B
 - Offset
 - A
 - B
 - Scale
 - A
 - B
 - On*1
 - Attenuation A/B
 - Scale A/B
 - Offset A/B
 - On*1
 - Define Function
 - CH A + CH B
 - CH A – CH B
 - CH B – CH A
 - Offset
 - Scale
 - Auto Scale
 - CH A
 - Off
 - On
 - CH A
 - Offset
 - Scale
 - CH B
 - Off
 - On
 - CH B
 - Offset
 - Scale
 - Clear Display

Marker

Off

On

All Off

Center

X1

Off

On

X2

Off

On

Y1

Off

On

Y2

Off

On

Measure

Active Channel Selection

Channel A

Channel B

Measurement Item

Amplitude/Time

Add

Average Power (dBm)*3

Average Power (mW)*3

Crossing

DCD

Extinction Rate*3

Eye Amplitude

Eye Height

Eye Width

Fall Time

Jitter p-p

Jitter RMS

OMA (dBm)*3

OMA (mW)*3

One Level

Rise Time

SNR

Zero Level

Correction Factor

Delete

Eye Boundary
 Offset from Crossing
 Width
Measuring Area Marker
 Item
Move
Rise/Fall Time
 10/90%
 20/80%
Rise/Fall Time Correction
 Off
 On
Amplitude/Time&Histogram
 Amp/Time
 Add
 Average Power (dBm)*3
 Average Power (mW)*3
 Crossing
 DCD
 Extinction Ratio*3
 Eye Amplitude
 Eye Height
 Eye Width
 Fall Time
 Jitter p-p
 Jitter RMS
 OMA (dBm)*3
 OMA (mW)*3
 One Level
 Rise Time
 SNR
 Zero Level
 Correction Factor
 Delete
 Eye Boundary
 Offset from Crossing
 Width
 Measuring Area Marker
 Item
 Move
 Rise/Fall Time
 10/90%
 20/80%
 Rise/Fall Time Correction

	Off
	On
Histogram	
Axis	
	Amplitude
	Time
Histogram Marker Center	
Marker	
	X1
	X2
	Y1
	Y2
Amplitude/Time&Mask	
Amp/Time	
Add	
	Average Power (dBm)*3
	Average Power (mW)*3
	Crossing
	DCD
	Extinction Ratio*3
	Eye Amplitude
	Eye Height
	Eye Width
	Fall Time
	Jitter p-p
	Jitter RMS
	OMA (dBm)*3
	OMA (mW)*3
	One Level
	Rise Time
SNR	
	Zero Level
Correction Factor	
Delete	
Eye Boundary	
	Offset from Crossing
	Width
Measuring Area Marker	
Item	
Move	
Rise/Fall Time	
	10/90%
	20/80%
Rise/Fall Time Correction	

Off
On

Mask Test

Align Method

User Defined

Alignment Marker

Display Off
Display On

ΔX
 ΔY
X1
Y1

Eye Mask Select

10GbE FEC
10GbE LAN
10GbE WAN
10GFC
10GFC FEC
1GbE
1GFC
2GbE
2GFC
4GFC
8GFC
8GFC_Elect_Rx
8GFC_Elect_Tx
OC12/STM4
OC192/STM64
OC192/STM64 FEC(G.975)
OC3/STM1
OC48/STM16
OTU-1
OTU-2 1310nm
OTU-2 1550nm
OTU-2 1550nm Expand
OTU-2 Amplified
User Defined

Mask Area Restriction

Off
On

Angle

-90 to 90

Width

0.01 to 1.00

	Mask Alignment Algorithm
	Zero/One/ Crossing
	Mask Alignment
	Update
	Mask Margin
	-100 to 100%
	Mask Margin Test
	Continuous
	One Shot
	Target Failed
Histogram	
Axis	
	Amplitude
	Time
	Histogram Marker Center
	Marker
	X1
	X2
	Y1
	Y2
Mask Test	
Align Method	
	User Defined
	Alignment Marker
	Display Off
	Display On
	ΔX
	ΔY
	X1
	Y1
Eye Mask Select	
	10GbE FEC
	10GbE LAN
	10GbE WAN
	10GFC
	10GFC FEC
	1GbE
	1GFC
	2GbE
	2GFC
	4GFC
	8GFC
	8GFC_Elect_Rx
	8GFC_Elect_Tx

- OC12/STM4
- OC192/STM64
- OC192/STM64 FEC(G.975)
- OC3/STM1
- OC48/STM16
- OTU-1
- OTU-2 1310nm
- OTU-2 1550nm
- OTU-2 1550nm Expand
- OTU-2 Amplified
- User Defined
- Mask Area Restriction
 - Off
 - On
 - Angle
 - 90 to 90
 - Width
 - 0.01 to 1.00
- Mask Alignment Algorithm
 - Zero/One/ Crossing
 - Mask Alignment
 - Update
- Mask Margin
 - 100 to 100%
- Mask Margin Test
 - Continuous
 - One Shot
 - Target Failed
- Off
- Setup
 - Accumulation Type
 - Averaging
 - Waveforms
 - Infinite
 - Limited
 - Limit Type
 - Sample
 - Samples
 - Time
 - Time
 - Waveform
 - Waveforms
 - None

Persistency
 Persistence Time
 Clock Recovery
 <2.7G*4
 >8.5G*4
 CRU Loop BW
 1 MHz
 2 MHz
 4 MHz
 8 MHz
 Off
 CRU Lock
 Continue Scan
 Label
 Delete Label
 Delete
 NEW Label
 Add
 Maintenance
 Calibration
 Application Test
 Number of Sampling
 509*5
 512*6
 1021*5
 1024*6
 1350*5
 2039*5
 2048*6
 4093*5
 4096*6
 8191*5
 8192*6
 16381*5
 16384*6
 Sampling Mode
 Coherent Eye
 Eye
 Fast Sampling Mode
 Off
 On
 Pulse
 Screen Copy

Eye/Pulse Shot
 Capture
Inverse background color
 Off
 On
Waveforms Only
 Off
 On
Trace Memory
 Clear Reference
 Ref.Trace Channel
 Ch A
 Ch A & Ch B
 Ch B
 Set Reference
Time
 Bits on Screen
 Data Clock Rate
 Tracking
 Off
 Acquire Clock Rate
 Auto Divide Ratio
 Clock Rate
 Bit Rate
 Divide Rate
 Recalculate Option
 Clock Rate
 Bit Rate
 Bit Rate
 Clock Rate
 On*2
 Master
 PPG1
 PPG2*7
 ED1
 ED2*7
Offset
 Pattern Length
 Tracking
 Off
 Length
 2 to 16777216
 On*2
 Master

PPG1
PPG2*7
PPG3*8
PPG4*8
ED1
ED2*7
ED3*8
ED4*8

Skew

Channel A

Channel B

Unit

Time

UI

- *1: When with the Option 021
- *2: When with the Option 011, 012, or 014
- *3: When with the Option 023
- *4: When with the Option 053, 054, or 055
- *5: When Sampling Mode is Eye
- *6: When Sampling Mode is Coherent Eye or Pulse
- *7: When with the Option 012 or 014
- *8: When with the Option 014

7.3 Restrictions for Setting Parameters

The restrictions for setting parameters vary depending on the model name and options.

Option 021

The measurement results of Average Power (dBm), Average Power (mW), Extinction Rate, OMA (mW), and OMA (dBm) at Amplitude/Time of the Measurement dialog box are invalid.

Option 023

Channel A/B Tracking and Channel Math in the Amplitude dialog box are not displayed.

Option 021 and 023

The following restrictions apply if none of the Option 011, 012, or 014 is selected.

- In the Time dialog box, Tracking for Data Clock Rate cannot be set to On.
- In the Time dialog box, Tracking for Pattern Length cannot be set to On.

7.4 Measurement Procedure

The following figure shows the basic measurement procedure.

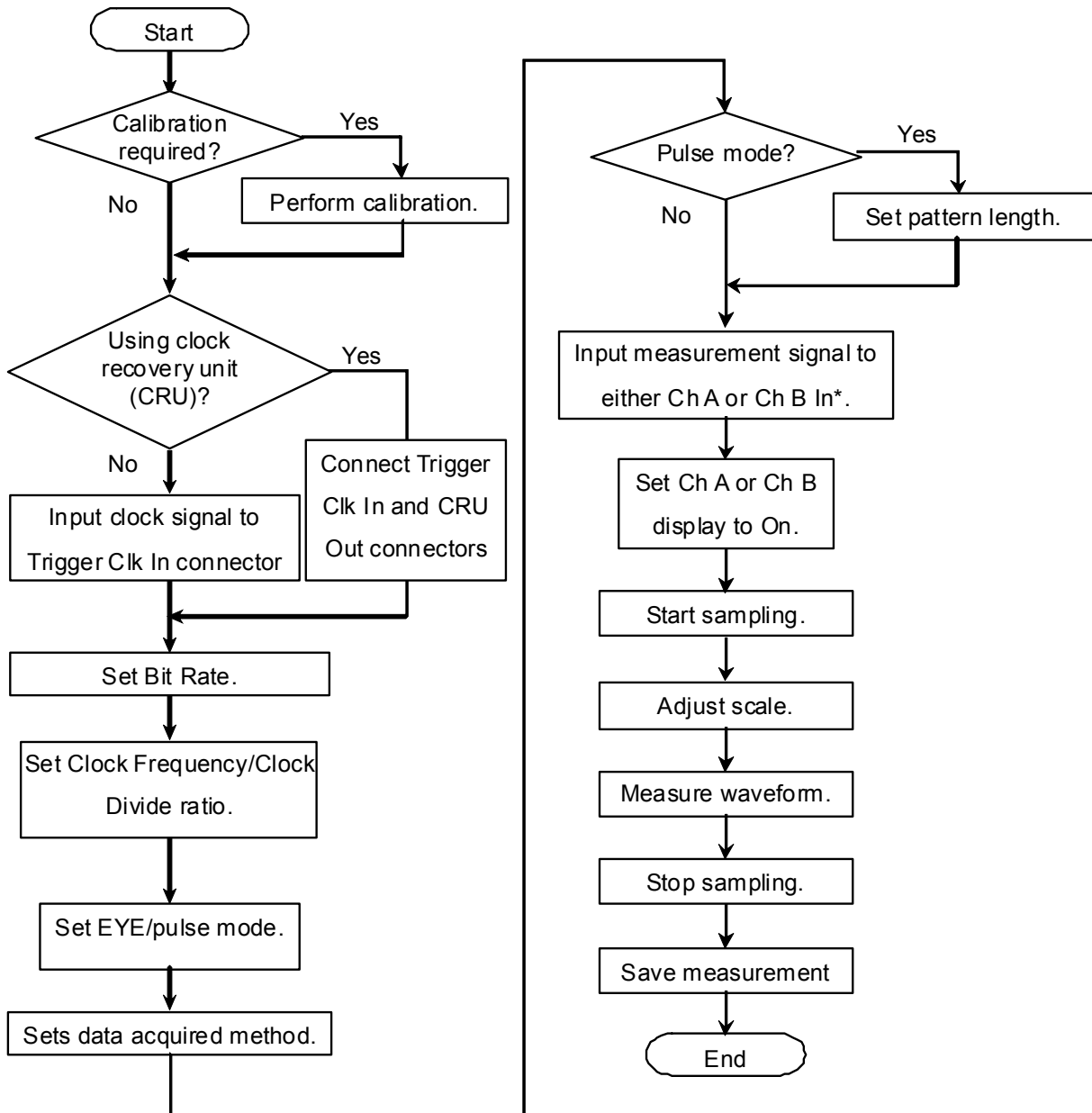

Figure 7.4-1 Basic Measurement Procedures

7.5 Calibrating Sampling Oscilloscope

7.5.1 Calibrating Level

The amplitude accuracy of the sampling oscilloscope is guaranteed after performing calibration.

When the calibration is required, the error message "Calibration is required" is displayed in the Setup dialog box in red.

Perform the calibration, when using the BERTWave for the first time or the message is displayed.

The calibration procedures are as follows:

1. Check that no signals are input to the front-panel Ch A In, Ch B In, or Trigger Clk In connectors.
2. Touch [Setup] to open the Setup dialog box.
3. Touch the [Utility] tab.
4. Touch [Calibration], and then the message is displayed to confirm that the signal is not input to the connector.

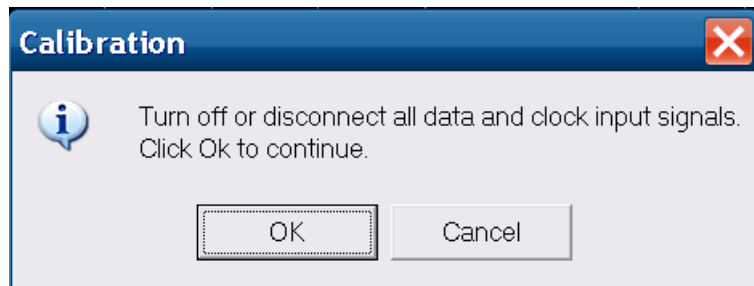

5. Touch [OK].

Upon completion of the calibration, a dialog box appears and gives you the calibration result.

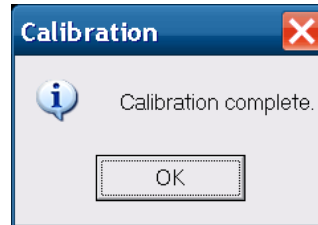
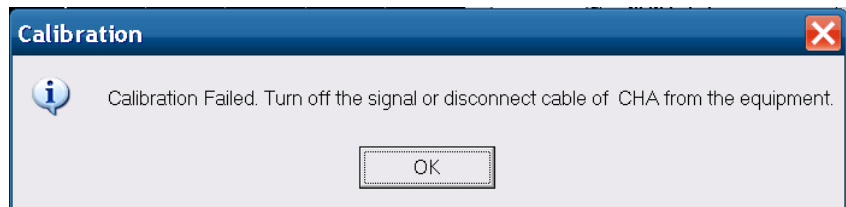
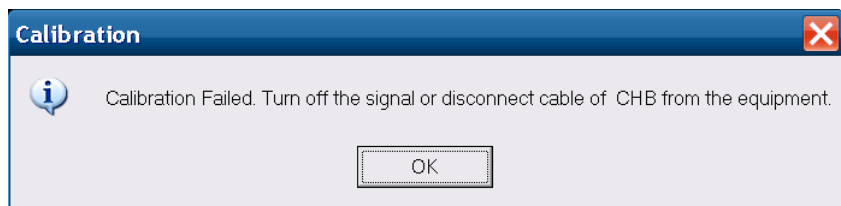

Figure 7.5.1-1 Calibration Result Display (When Calibration Is Successful)



When the Calibration of CHA Fails



When the Calibration of CHB Fails

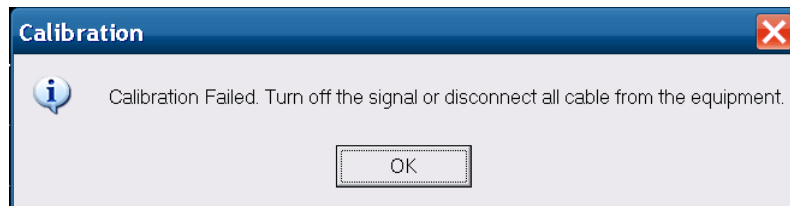

When the Calibration of CHA and CHB Fails

Figure 7.5.1-2 Calibration Result Display (When Calibration Fails)

If the calibration fails, follow the instruction that applies to your situation, and then retry from step 2.

- Check that the coaxial cable is not connected to any of the Ch A In, Ch B In and Trigger Clk In connectors on the front panel.
- If it is required to keep the coaxial cables connected to the Ch A In, Ch B In and Trigger Clk In connectors on the front panel, check that the connectors do not receive any incoming signal.

After the following operations, CAL alarm is displayed on the screen.
When the CAL alarm is displayed, calibrate the level.

- Change [Sampling Mode] in the Setup dialog box.
- When Sampling Mode is [Pulse] or [Coherent Eye], change [Pattern Length] in the Time dialog box.

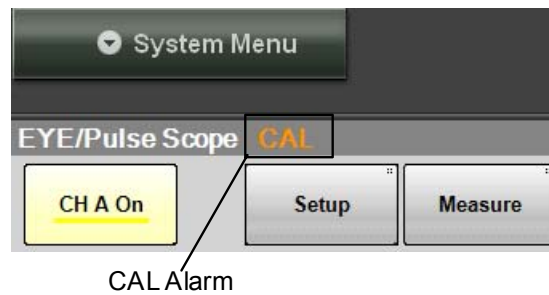

Figure 7.5.1-3 CAL Alarm Display

7.5.2 Performing Self Test

Perform the self test in the following cases:

- When the error message is displayed after level calibration referring to 7.5.1 “Calibrating Level”
- When the noise voltage is over the specified value shown in Appendix A when the signal is not input
- When the waveform is not displayed, the displayed waveform amplitude and bit cycle is different from the expected value, and the BERTWave operation and measurement results are abnormal.

The application self test runs following items.

- Power
- Frequency
- Amplitude

If the test result is normal, “passed” is displayed, on the other hand, if the test result is abnormal, “failed” is displayed.

The self test procedures are as follows.

1. Check that no signals are input to the front-panel Ch A In, Ch B In, Trigger Clk In connectors.
2. Touch [Setup] to open the Setup dialog box.
3. Touch the [Utilities] tab.

4. Touch [Application Test]. The self test dialog box is displayed while the self test is running.
5. After the self test is completed, the result is displayed.

When the power supply test result is failed:

1. When the power voltage is displayed, record the value.
2. If the power supply test result shows “failed”, contact an Anritsu Service and Sales office.

When the frequency test result is failed:

1. Check that no signals are input to the Trigger Clk In connector.
2. Perform the self test again.
3. If the frequency test result shows “failed”, calibrate the sampling oscilloscope again. And then, perform the self test again. Nonetheless, in cases where the test result fails, contact an Anritsu Service and Sales office.
4. Perform the self test again.
5. Nonetheless, in cases where the test result fails, contact an Anritsu Service and Sales office.

When the amplitude test result is failed:

1. Check that no signals are input to the Ch A In, Ch B In connectors.
2. Perform the self test again.
3. If the amplitude test result shows “failed”, calibrate the sampling oscilloscope again.
4. Perform the self test again.
5. Nonetheless, in cases where the test result fails, contact an Anritsu Service and Sales office.

7.6 Setting Clock Recovery and Rate

The trigger clock synchronized with the input signal is required to collect data.

With the Options 011, 012, or 014, the PPG or ED synchronizing clock (Sync Out) can be used.

The clock can be generated from the signal input to the following connectors if the Option 053, 054, 055 clock recovery units are added to the BERTWave.

- Option 053: CRU In connector on the front panel
- Option 054: O/E Data In connector on the front panel
- Option 055: Data/CRU In connector of ED1

In this case, connect CRU Out on the front panel to Trigger Clk In using a coaxial cable.

After the trigger clock is input to the BERTWave, the bit rate, clock rate, and divide rate is set.

The bit rate is the signal input to Ch A or Ch B.

The clock rate is the frequency of the trigger clock.

Divide Rate is the rate between data bit rate and clock rate.

The value should be inputted to complete the following formula.

$$\text{Bit Rate} = \text{Clock Rate} \times \text{Divide Rate}$$

 **CAUTION**

- **The impedance of the Trigger Clk In connector is 50 Ω. Measurement may not be performed correctly if a cable with another impedance is used.**
 - **The amplitude of the signal input to the Trigger Clk In connector is 2 Vp-p max. This is equivalent to + 10 dBm for a sine-wave signal. Inputting a signal with a larger voltage risks damaging the internal circuits.**
-

7.6.1 Setting Clock Recovery Unit

The Option 053, 054, or 055 Clock Recover Unit (CRU) can generate a clock from the signal collecting data.

The waveform can be measured using the generated clock.

The following can be set using the clock recovery unit.

- Clock Recovery
- CRU Loop BW

CRU Input sets the input connector for the clock recovery unit.

Clock Recovery sets the output On/Off and frequency range.

CRU Loop BW is the loop filter bandwidth used at the frequency control circuit for CRU.

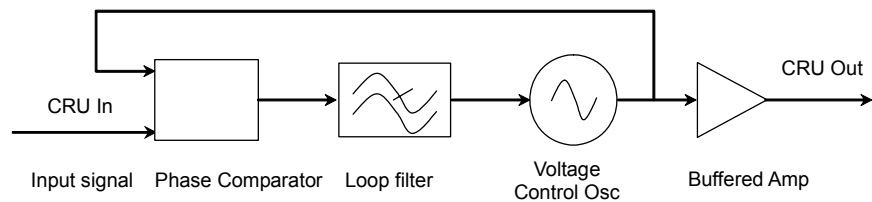

Figure 7.6.1-1 Block Diagram of Clock Recovery Unit

Although the frequency band is wide, instantaneous frequency fluctuations can be buffered. The communications standards specify the loop filter bandwidth used to measure jitter.



CAUTION

- The impedance of the CRU In and CRU Out connectors is 50 Ω . Measurement may not be performed correctly if a cable with another impedance is used or if the impedance of the connected device is not 50 Ω .
- The CRU Out connector output voltage is 0.5 to 1.5 Vp-p between 8.5 GHz and 12.5 GHz, and 0.27 to 0.54 Vp-p for 2.7 GHz or lower. Check that the output voltage does not exceed the connected device maximum input specifications. If it does, connect an attenuator to the CRU Out connector.

 **CAUTION**

- **Set the amplitude of the signal input to the CRU In connector to not exceed the following values. This is equivalent to + 10 dBm for a sine-wave signal. Inputting a signal with a larger voltage risks damaging the internal circuits.**

Option 053: 2 Vp-p

Option 054: -1 dBm (mean)

Option 055: 1.0 Vp-p

Procedure

1. Connect the Trigger CLK In and CRU Out connectors on the front panel using a coaxial cable.
2. With the Option 053, input the signal to the front panel CRU In connector.

With the Option 054, input the signal to the front panel O/E Data In connector.

With the Option 055, input the signal to the front panel ED1-Data CRU In connector.

3. Touch [EYE/Pulse Scope].
4. Touch [Setup].
5. Touch the Clock Recovery button to select CRU Band from the following items.

[Off]: Turn off the clock output to CRU Out connector.

[<2.7]: Sets the CRU from 0.1 to 2.7 GHz.

[>8.5] Sets the CRU from 8.5 to 12.5 GHz.

When setting to [<2.7] or [>8.5], “*CRU Valid” is displayed.

6. When Clock Recovery is [>8.5], select the CRU loop BW from the following:

[1 MHz], [2 MHz], [4 MHz], [8 MHz]

7. Touch [Time].
8. Set the divide rate to 1.
9. Touch [Acquire Clock Rate] at Acquire Clock Rate.

Note:

When not using the clock recovery unit, set Clock Recovery to [OFF]. The clock recovery may not be generated if the input signal frequency to the clock recovery is out of CRU Band. In that case, the [PLL Unlocked] is displayed.

When using the clock recovery unit, the bit rate displayed on the right bottom side of the waveform area might not be an expected value. In this case, touch [Continue Scan] at the CRU Lock.

7.6.2 Setting Bit Rate

1. Touch [Time].
2. Touch the Tracking button at Data Clock Rate, and set to [Off].
3. Touch the Recalculate Option button to select [Clock Rate].
4. Touch the Divide Rate text box.
5. Input the divide rate.
6. Touch the Bit Rate text box to input the bit rate.

The clock rate is calculated using the divide rate and bit rate.

The bit rate and divide rate are set so that the clock rate is set to 15 000 000 kHz or less.

When using the BERTWave, the bit rate for the PPG and the ED can be set to the bit rate for the sampling oscilloscope using the following procedures.

1. Touch [Time].
2. Touch the Tracking button at Data Clock Rate, and set to [Tracking On].
3. Touch the Master button of Data Clock Rate and select from the following units matching the bit rate.

[PPG1]: PPG/ED Ch1

[PPG2]: PPG/ED Ch2

When selecting Master, the bit rate, divide rate, and clock rate values are reflected.

7.6.3 Setting Clock Rate and Divide Rate

The bit rate can be set by measuring the clock rate from the signal input to the Trigger Clk In connector of the front panel.

1. Touch [Time].
2. Touch the Tracking button of the Data Clock Rate to set to [Off].
3. Touch the Recalculate Option button to select [Bit Rate].
4. Touch [Acquire Clock Rate].

The frequency is displayed in the Clock Rate text box.

Confirm the waveform and signal level input to the Trigger Clk In connector when the frequency is not displayed.

5. When the clock frequency is not displayed at Clock Rate or the displayed frequency is not correct, touch the Clock Rate text box and input the frequency.

6. Touch the Divide Rate text box and input the divide rate.

The bit rate is calculated by the divide rate and clock rate.

When using the BERTWave Sync Out as an external clock, the divide rate is set as follows.

Sync Output settings	Divide Rate
PPG1_1/1 CLK, PPG2_1/1 CLK	1
PPG1_1/2_CLK, PPG2_1/2 CLK	2
PPG1_1/4_CLK, PPG2_1/4 CLK	4
PPG1_1/8 CLK, PPG2_1/8 CLK	8
PPG1_1/16 CLK, PPG2_1/16 CLK	16
PPG1_1/64_CLK, PPG2_1/64 CLK	64
ED1_1/4 CLK, ED2_1/4 CLK, ED3_1/4 CLK, ED4_1/4 CLK	4
ED1_1/8 CLK, ED2_1/8 CLK, ED3_1/8 CLK, ED4_1/8 CLK	8
ED1_1/16 CLK, ED2_1/8 CLK, ED3_1/8 CLK, ED4_1/8 CLK	16

When setting Sync Output to PPG_1Ch_Pattern Sync or PPG_2Ch_Pattern Sync, the data cannot be collected.

7.7 Setting Data Collection Method

The data collection method is composed of the following types.

Data synchronized method: Eye mode, Pulse mode, Coherent eye mode

Cumulative display for waveform: None, Infinite, Limited, Persistency, Average

Note:

In this document, measurement of one data item on the screen is described as “data capture” while obtaining one screen of data is described as “data collection”.

To switch to Eye/Pulse/Coherent mode

1. Touch [Setup].
2. In the Setup dialog box, touch the Sampling Mode button to change it to [Eye], [Pulse], or [Coherent Eye].

The Coherent Eye mode is used when calculating the waveform of Channel A and Channel B.

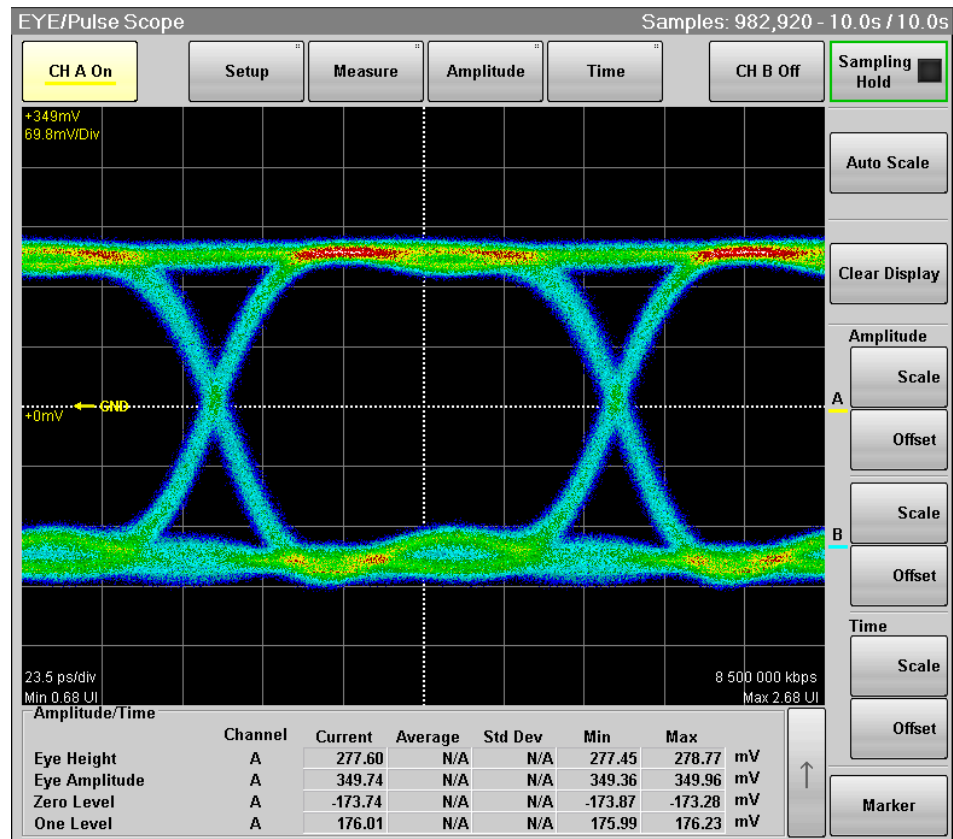

Figure 7.7-1 Eye Mode/Coherent Mode Display Example

4. When selecting [Limited] at step 3, set the at-end condition.
 - To end overwriting waveform when the set time is passed, set Limit Type to [Time].
Touch the Time text box to input the time.
 - To end overwriting waveform when the data count set at the screen is reached, set Limit Type to [Sample].
Touch the Samples text box to input the number of data.
 - To stop waveform overwriting when the set time has elapsed, set Limit Type to [Waveform].
Touch the Waveforms text box to input the number of waveforms.
5. When [Persistency] is selected at step 3, set the time for saving the overwritten data.
Touch the Time text box to input the time.

Deleting overwritten waveform display

1. Touch [Setup] to open the Setup dialog box.
2. Touch the Accumulation Type button to select [None].
3. Touch the Number of samples button to select the number of data displayed on the screen from the following:
For [Eye]: [509],[1021], [1350], [2039],[4093],[8191],[16381]
For [Pulse],[Coherent Eye]:
[512],[1024],[2048],[4096],[8192],[16384]

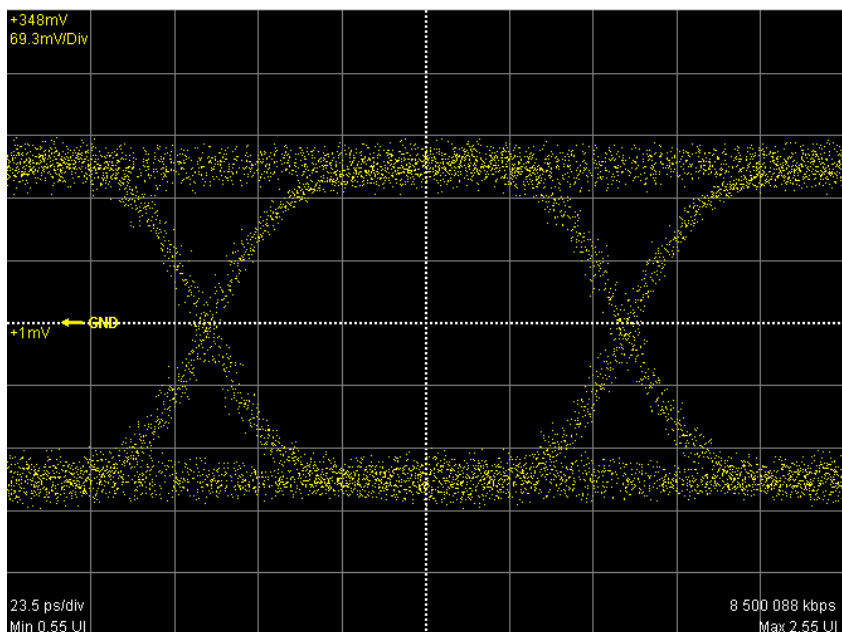

Figure 7.7-3 Accumulation Type Settings (None)

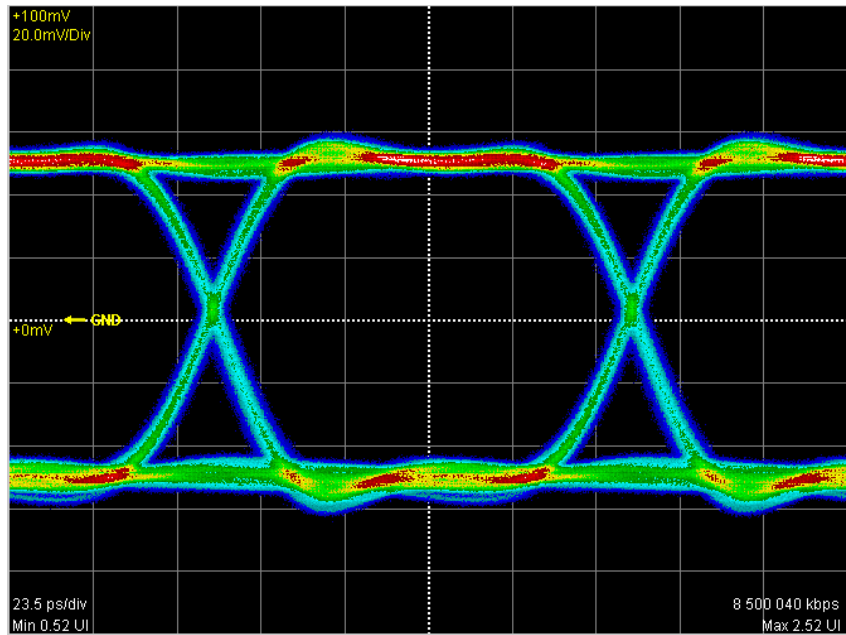

Figure 7.7-4 Accumulation Type Settings (Infinite)

Displaying averaging waveform

When setting the display method to [Averaging] at the pulse mode, the averaging process is performed. Averaging process is used to suppress waveform noise.

1. Touch [Setup] to open the Setup dialog box.
2. Touch the Accumulation Type button to select [Averaging].
3. Touch the Number of samples button to select the number of data displayed on the screen from the following:
[512], [1024], [2048], [4096], [8192],[16384]
4. Touch the Averaging text box to set the number of waveforms to perform averaging.

In averaging, the mean value of the data count input at Averaging is calculated and the results are displayed on the screen. However, when 1 is input, no averaging is performed.

The number of averaging waveforms is displayed on the screen while executing averaging.

The waveform is captured ten times when the following condition is set, and ten averaging waveforms are displayed.

- Accumulation Type Average
- Averaging 100 wfms

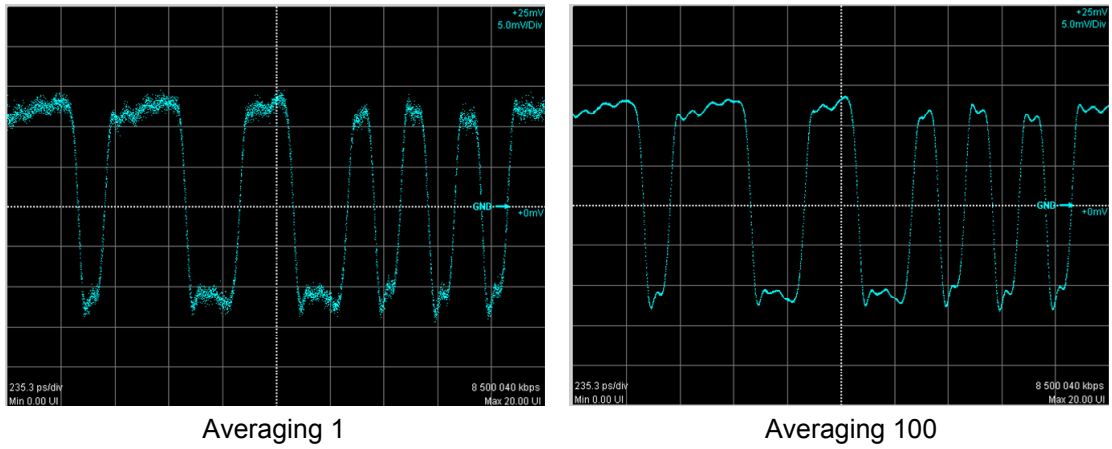

Figure 7.7-5 Example of Averaging Process

The averaging is calculated using the following formula.

Number of waveforms \leq Averaging setting count:

$$Ave(n) = \frac{(n-1) \times Ave(n-1) + S(n)}{n}$$

Averaging setting count \leq Number of waveforms:

$$Ave(n) = \frac{(M-1) \times Ave(n-1) + S(n)}{M}$$

Ave(n): Averaging value, S(n): Measurement value, M: Averaging setting count, n: Number of waveforms

The size of the noise is inversely proportional to the square root of the averaging setting count.

For example, if M is set to 100, the noise amplitude is compressed to about 1/10 compared to when M is set to 1.

7.8 Setting Pattern Length

When the Pulse mode is set as described in Section 7.7 “Setting Data Collection Method”, the pattern length can be set.

In the Pulse mode, the pattern is synchronized by collecting data at the pattern length time cycle.

1. Touch [Time].
2. Touch the Tracking button at Pattern Length to set to [Off].
3. Touch the Length text box at Pattern Length.
4. Input the pattern length by the bit unit.

Note:

The settable pattern length is up to 1677216 (2^{24}).

When Text Pattern at PPG/ED is $2^{31}-1$, [Tracking On] cannot be set to Tracking at Pattern Length.

When Pattern Length is set to [Tracking On], Test Pattern at PPG/ED cannot be set to $2^{31}-1$.

When changing the PPG/ED pattern length settings using the BERTWave, the changed setting values can be set to the sampling oscilloscope automatically.

1. Touch [Time].
2. Touch the Tracking button at Pattern Length, and then set to [On].
3. Touch the Master button at Pattern Length.
4. Select the PPG and ED with equal pattern lengths.

7.9 Collecting Data

Once the data collection is started, the waveform is displayed on the screen.

Starting data collection

1. The waveform of the channel with the monitor signal input is displayed.

When monitoring the signal input to the Ch A In connector, touch the Channel A trace display button to set the button display to [CH A On].

When monitoring the signal input to the Ch B In connector, touch the Channel B trace display button to set the button display to [CH B On].

2. Touch the sampling start/stop button to display [Sampling at the button display.

The elapsed time, number of samples and number of waveforms are displayed in the title bar when [Accumulation Type] is set to [Limited].

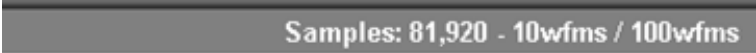

Samples: 81,920 - 10wfms / 100wfms

When [Averaging] is set to 2 or more in the Pulse mode, the number of waveforms is displayed in the title bar.

The data collection can also be started by the [All Measurements Start] button shown in Figure 4.1-1.

Stopping data collection

Touch the sampling start/stop button, and then set to [Sampling Hold]. When, in the Setup dialog box, Accumulation Type is set to [Limited], the data collection process stops when the at-end conditions are met.

The data collection can be started by touching all measurement stop button as shown in Figure 4.1-1.

Discarding screen display

When temporarily deleting screen display:

Touch the Channel A trace display button, and then set the button display to [CH A Off].

Touch the Channel B trace display button, and then set the button display to [CH B Off].

The waveform is displayed when setting the button display to [CH A On] or [CH B On].

When discarding collected data:

Touch [Clear Display].

The waveform is deleted even when the button display is set to [CH A On] or [CH B On].

The discarded data cannot be displayed again.

7.10 Adjusting Screen Scale

7.10.1 Adjusting scale automatically

Measure the waveform amplitude and period, and then set to the easily viewable scale.

For Eye/Pulse/Coherent Mode

1. Touch [Auto Scale].
2. The waveform is displayed at the center of the screen.

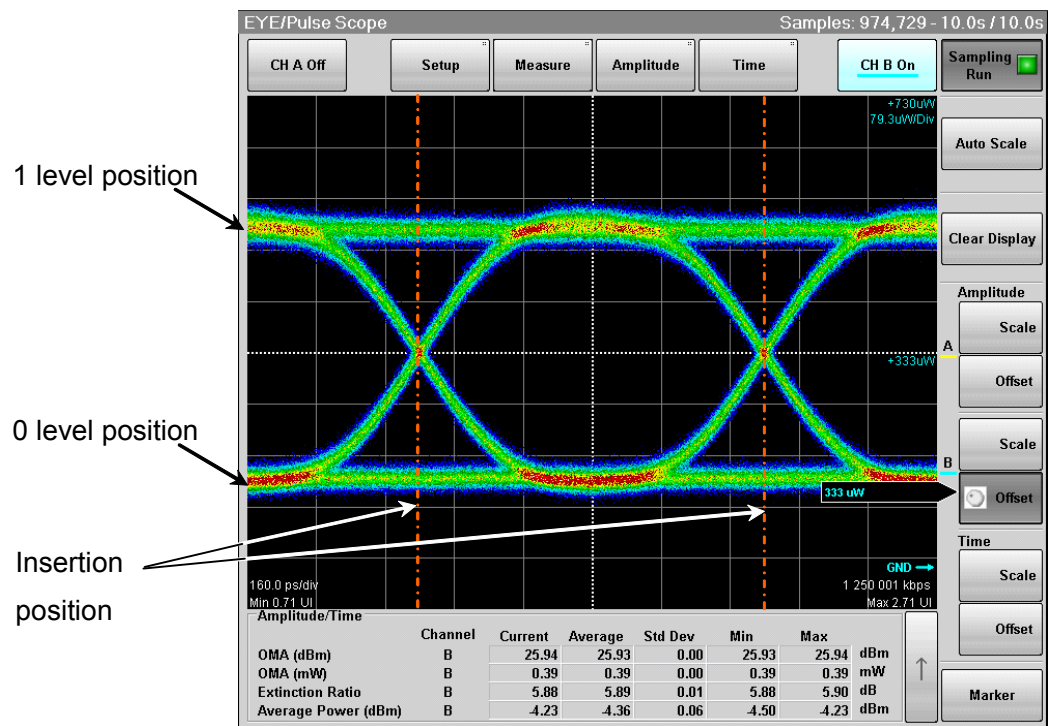

Figure 7.10.1-1 Waveform Display after Auto Scale (Eye/Pulse/Coherent Mode)

When adjusting scale automatically, the two-bit waveform is displayed on the horizontal axis.

The Eye pattern waveform crossing points are 2.5 and 7.5 scale divisions from the left side.

At the vertical axis, “one” level 2.5 gridlines above center of grid, “zero” level 2.5 gridlines below center of grid.

Note:

When both CH A and CH B are set to ON, the offset at the time axis is adjusted according to the channel signal selected at Active Channel Selection.

For Pulse Mode

1. Touch [Auto Scale].
2. The waveform is displayed at the screen center.

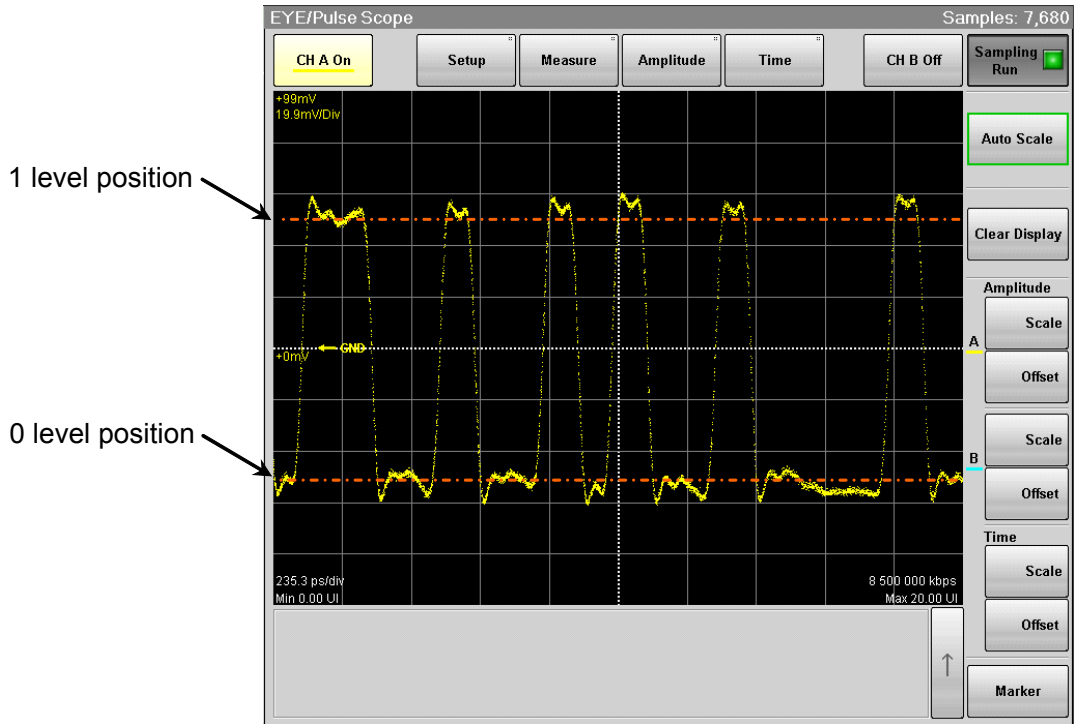

Figure 7.10.1-2 Waveform Display after Auto Scale (Pulse Mode)

When the pattern length is 127 bits or less, a 20-bit waveform is displayed. When the pattern length is 128 bits or more, a 50-bit waveform is displayed.

The 1 level is adjusted on the vertical scale to the 2.5th scale up from the screen center and the 0 level is adjusted to the 2.5th scale down from the screen center.

7.10.2 Adjusting Vertical-axis of Screen

To adjust voltage or optical power at center of vertical axis

1. Touch [Offset] at Amplitude on the left side of the waveform display area.

The rotary knob icon is displayed in the button.

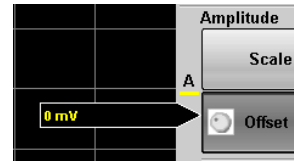

2. Input the power voltage or optical power at the screen center position using the rotary knob.
3. When using the trace A, the input value is displayed at the left center of the waveform display area.
When using the trace B, the input value is displayed at the right center of the waveform display area.

To adjust voltage or optical power per scale:

1. Touch [Scale] at Amplitude in the right side of the waveform display area.
The rotary knob icon is displayed in the button.
2. Input the voltage or optical power per scale using the rotary knob.
3. When using the trace A, the input value is displayed at the left upper corner of the waveform display area.
When using the trace B, the input value is displayed at the right upper corner of the waveform display area.

The vertical-axis can also be adjusted by directly entering the value in the Amplitude dialog box.

1. Touch [Amplitude].
2. Touch the Offset text box.
3. Input the voltage or optical power at the screen center position.
4. Touch the Scale text box.
5. Input the voltage or optical power per scale.

Setting same vertical scale for two waveforms

The vertical scales at Channel A and Channel B can be set to the equal value using the Option 021.

1. Touch [Amplitude].
2. Touch the Channel A/B Tracking button, and set to [On].
And then, the text box for Channel A is only available.
3. Touch the Scale, Offset, and Attenuation text boxes, and then set the value.

Note:

When the Channel A/B Tracking is set to [On], the CH B scale, offset, and attenuator value are changed to the CH A values.

Touch [Scale] and [Offset] at Amplitude on the right side of the screen, and then the value set using the rotary knob will be valid. In this case, the CH B scale and offset values are not displayed in the Amplitude dialog box.

7.10.3 Adjusting Horizontal-axis of Screen

Adjusting time at left edge of screen

1. Touch [Offset] at Time in the right side of the waveform display area. The rotary knob icon is displayed in the button.
2. Input the time at left edge of screen using the rotary knob.
3. The time entered is displayed at the left lower corner of the waveform display.

To switch the horizontal position units between UI (unit interval) and time (ps), touch [Time] and the Unit button.

Adjusting the number of bits to display

Result window

1. Touch [Scale] at Time in the right side of the waveform display area. The rotary knob icon is displayed in the button.
2. Input the number of bits per scale using the rotary knob.
3. The sum of the value at the bottom left of the screen and the input value is displayed at the bottom right.

Time dialog box

1. Touch [Time].
2. Touch the [Scale/Offset] tab.
3. Touch Bits on Screen text box.
4. Input the number of bits.

Adjusting the waveform position

1. Touch [Time].
2. Touch the [Scale/Offset] tab.
Changing Offset can adjust the position of single waveform,
3. Touch the Skew text box and input the values.

The waveform moves right when a positive value is set.

The waveform moves left when a negative value is set.

7.10.4 Calibrating attenuation of Adjusting External Attenuator

Adjusting attenuation of external attenuator

The attenuation amount of an external attenuator connected to the Ch A In and Ch B In connectors can be adjusted as described below.

1. Touch [Amplitude].
2. Touch the Attenuation text box.
3. Input the attenuation.

The n dB attenuation is calculated by the following formula:

$$\text{Electrical input: } 10^{\frac{n}{20}}$$

$$\text{Optical input: } 10^{\frac{n}{10}}$$

7.11 Measuring Waveform

The waveform measurement methods are as follows.

For the explanation of the measurement items, refer to 1.5 “Technical Terms”.

- Amplitude and time measurements
Select the measurement items from the following:
Average power, Crossing%, Duty cycle distortion, Extinction rate, Eye amplitude, Eye height, Eye width, Fall time, Jitter p-p, Jitter RMS, One level, Rise time, SNR, Zero level, OMA
The extinction rate, average optical power, and OMA can be measured when using the O/E converter.
- Histogram
Sets the screen field and displays the data distribution in the time or amplitude direction and the measurement results.
- Mask test
Sets the mask pattern and mask margin, and then measures the data count in the mask.
The set data count can measure the mask margin within the mask.

Table 7.11-1 Measurement Method per Displayed Mode

Measurement Method	Eye Mode	Pulse Mode	Coherent Mode
Measurement for amplitude and time	✓	–	✓
Histogram	✓	✓	✓
Mask test	✓	✓	✓

7.11.1 Amplitude and Time Measurements

When collecting data in the Eye pattern mode, up to 4 amplitude and time measurements can be performed.

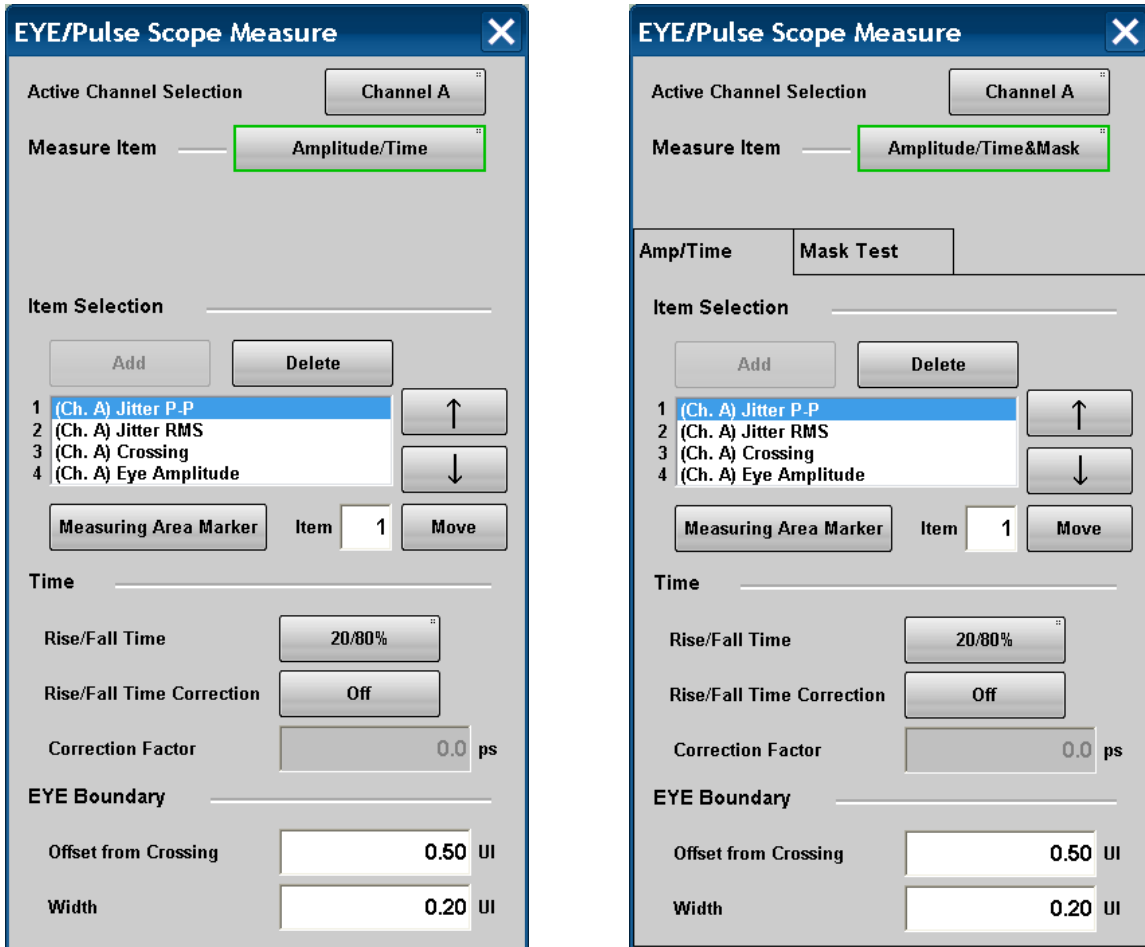

Figure 7.11.1-1 Setting Example of Amplitude/Time Measurement

To set measurement items:

1. Touch [Measure] to open the Measure dialog box.
2. Touch the Measure Item button.
3. Touch [Amplitude/Time], [Amplitude/Time&Mask], or [Amp/Histogram].
4. When selecting [Amplitude/Time&Mask] or [Amp/Histogram], touch the [Amp/Time] tab.
5. Touch [Add] at Item Selection.
The screen for selecting the measurement items is displayed.
6. Touch the measurement item.
7. The screen for selecting the channel is displayed.
Touch [Channel A] or [Channel B].
8. The item selected for the Item Selection list is added.
9. The measurement result is displayed in the button of the screen.

Up to 4 items can be selected. If you want to change the item, delete one of the selected items first.

If the added item is the same as an item selected already for the same channel, that item cannot be added using Item Selection.

To display measurement area

The marker shows which part of the waveform is measured.

1. Touch [Measuring Area Marker] . The display changes when the button is pressed. The measurement area is indicated by the marker (EYE Boundary).
2. The measurement number displayed in the measurement area can be set by touching the Item text box.
3. The measurement item in the measurement result display area is displayed in blue characters.

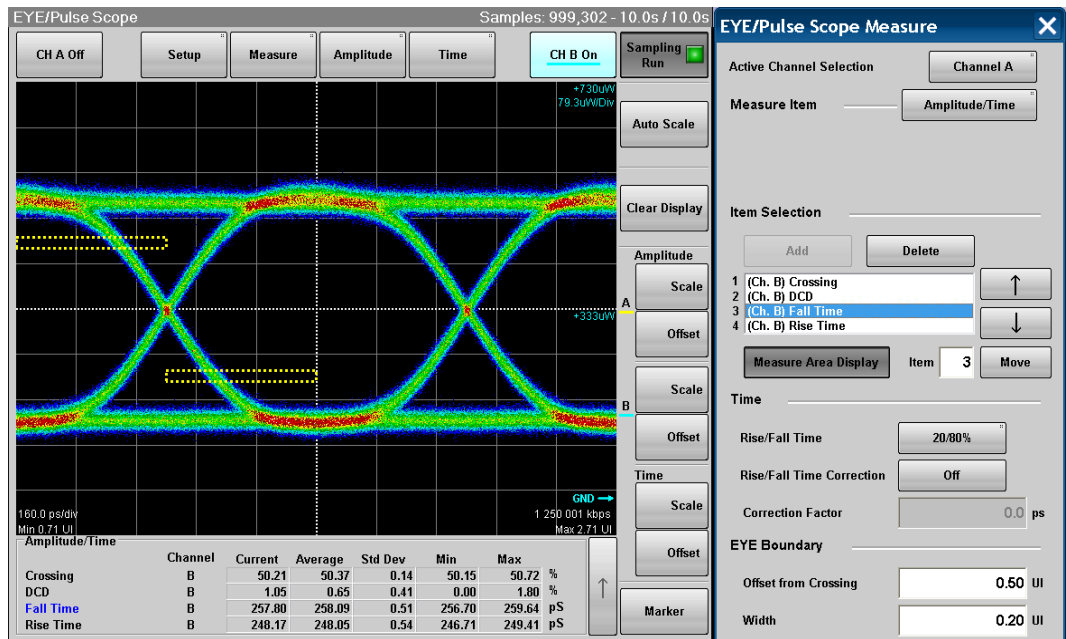

Figure 7.11.1-2 Display Example of EYE Boundary

When there is a possibility the waveform may not have been measured correctly due to too small amplitude or too large jitter, “EYE?” and channel name (CHA/CHB/CHA,CHB)” in red is indicated as shown below. In this case, check the settings for the amplitude and trigger of the measured signal and make sure the connectors are secure.

Amplitude/Time		
EYE? CHA	Channel	Current
Extinction Ratio *Corrected	B	N/A dB
Eye Amplitude	A	376.25 mV
Rise Time	A	23.26 pS
Fall Time	A	22.55 pS

Figure 7.11.1-3 Appearance of Amplitude/Time Area (When Measurement Results May Be Incorrect)

To change EYE Boundary

The 1 and 0 level measurement area can be changed.

1. Touch the Offset in the Crossing text box to set the area center position.
2. Touch the Width text box to set the area width.

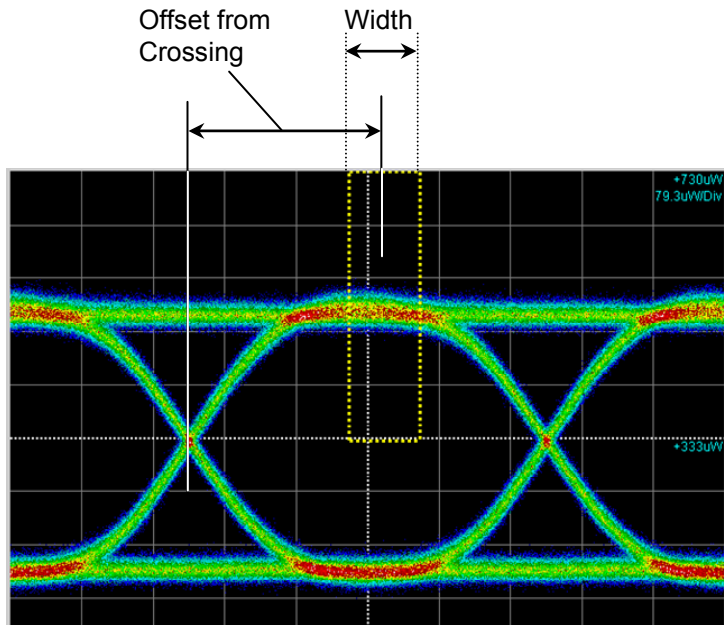

Figure 7.11.1-4 Setting Item of EYE Boundary

To set measurement method of rise/fall time

When measuring the rise time and fall time levels, select from amplitude 10/90% level or 20/80% level.

- Touch the Rise/Fall Time button to display [10/90%] or [20/80%].

The bandwidth of the sampling oscilloscope is corrected with the measurement value of the Rise/Fall time, and the corrected bandwidth is displayed.

1. Touch [Rise/Fall Time Correction] to set the button display to [On].
2. Touch the Correction Factor text box.
3. Input the correction value in ps.

The calculation formula is as follows:

$$Td = \sqrt{Tm^2 - Tc^2}$$

Td: display value (ps), Tm: measurement value (ps),

Tc: correction value (ps)

If the measurement value is larger than the correction value, the result displays N/A.

"Corrected" is displayed in red at the Rise/Fall time when Rise/Fall Time Correction is set to [On].

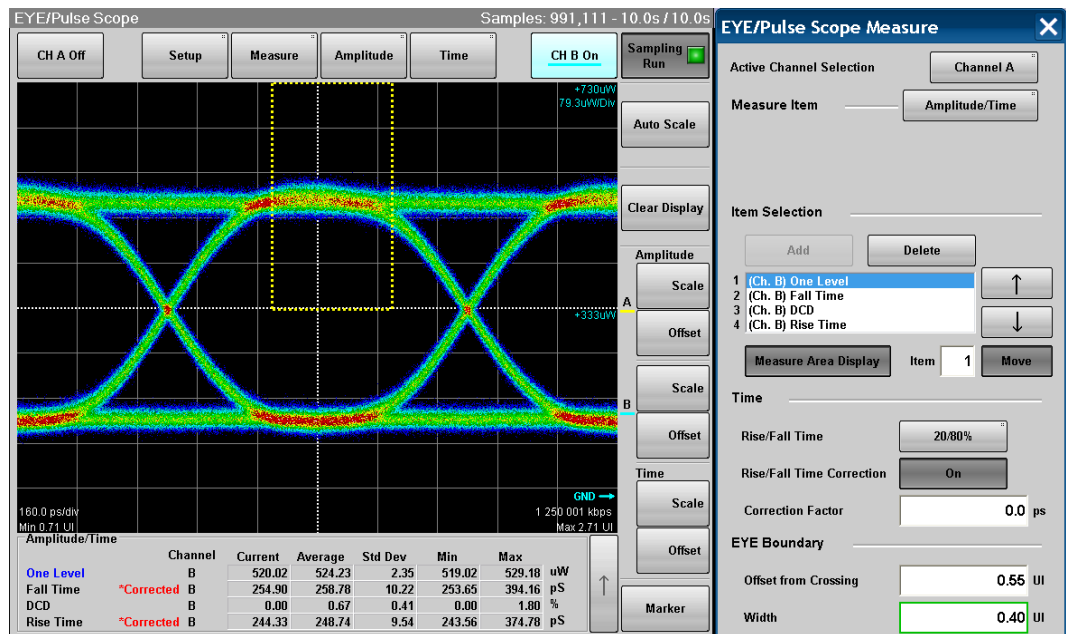

Figure 7.11.1-5 Display Example of Measurement Result

To change display order

The display order of the measurement result is the same as that of Item Selection. The display order of Item Selection can be changed using the following procedures.

1. Touch [↑] or [↓] at Item Selection to highlight the item for changing the display order.
2. Touch [Move], and then the button display is changed to the in-use display.
3. Touch [↑] or [↓] to move the highlighted items.
4. Touch [Move], and then the button display is restored to the normal display.

To delete items

1. Touch [↑] or [↓] at Item Selection to highlight the deleting items.
2. Touch [Delete] to delete the item form the list.

7.11.2 Displaying Histogram

The histogram display displays the data distribution in the set field to measure the mean, standard deviation, and dispersion width. To display histogram, set the axis, time, or amplitude for measuring histogram. And then, set the screen area to display histogram using the histogram marker. Also, the histogram marker position can be set by touching the screen or using the mouse.

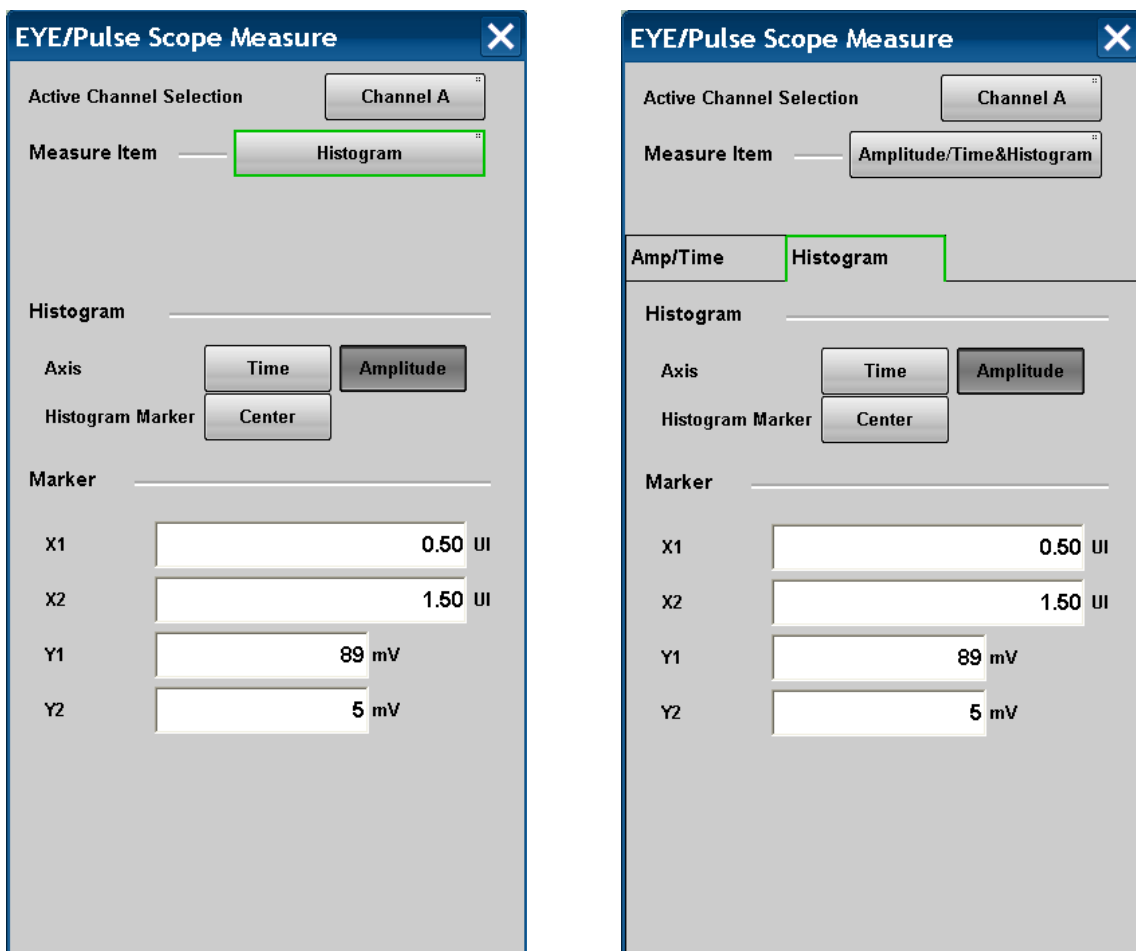
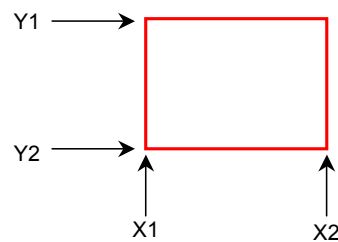

Figure 7.11.2-1 Setting Example of Histogram Measurement

1. Touch [Measure] to open the Measure dialog box.
2. Touch the Active Channel Selection button, and then select the channel to be measured.
3. Touch the Measure Item button.
4. Touch [Histogram], or [Amp/Histogram].
5. When selecting [Amp/Histogram], touch the [Histogram] tab.
6. When measuring histogram for time direction, touch [Time] at [Axis].
When measuring histogram for amplitude direction, touch [Amplitude] at [Axis].
7. Input the value to the histogram marker X1, X2, Y1, and Y2, and then set the area.

The area border to set the histogram marker is as shown in the following figure.



Toughing the screen and dragging the marker change the histogram marker position.

8. The measurement result of the data within the area is displayed.
 - Mean: average value
 - std Dev: standard deviation
 - P-P: difference between maximum value and minimum value (Peak to Peak)
 - Hits: data count within area

To display marker at screen center:

Touch [Center] at Histogram Marker to center the marker in the middle of screen.

When histogram measurement is turned on, depending upon the previous settings, the X and Y coordinates of the histogram window may be set beyond the boundaries of the current display screen. If this occurs, touching [Center] at Histogram Marker makes it easy to set the area.

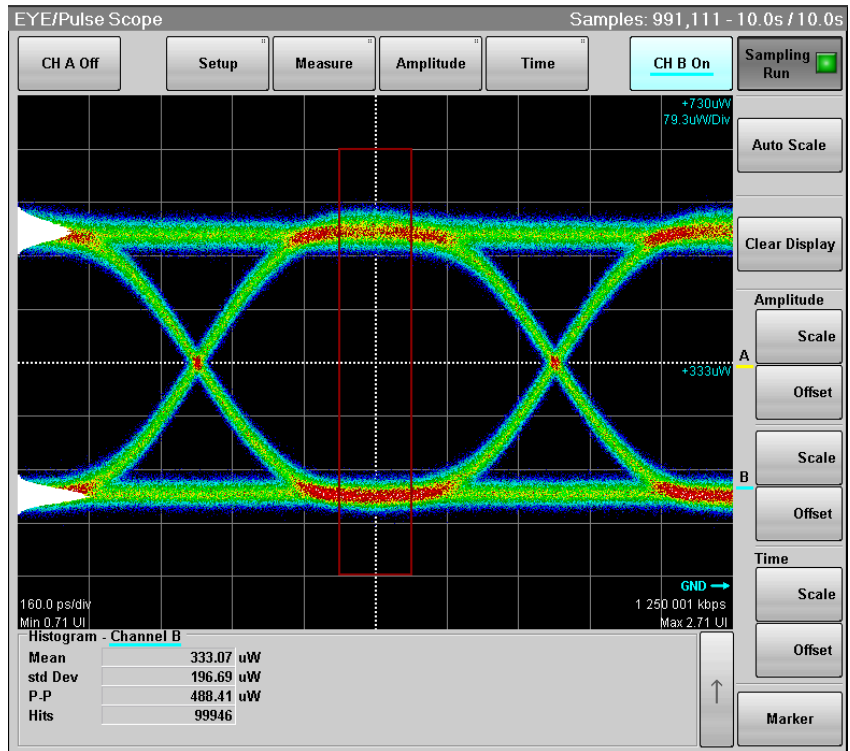

Figure 7.11.2-2 Histogram Measurement Example (Amplitude)

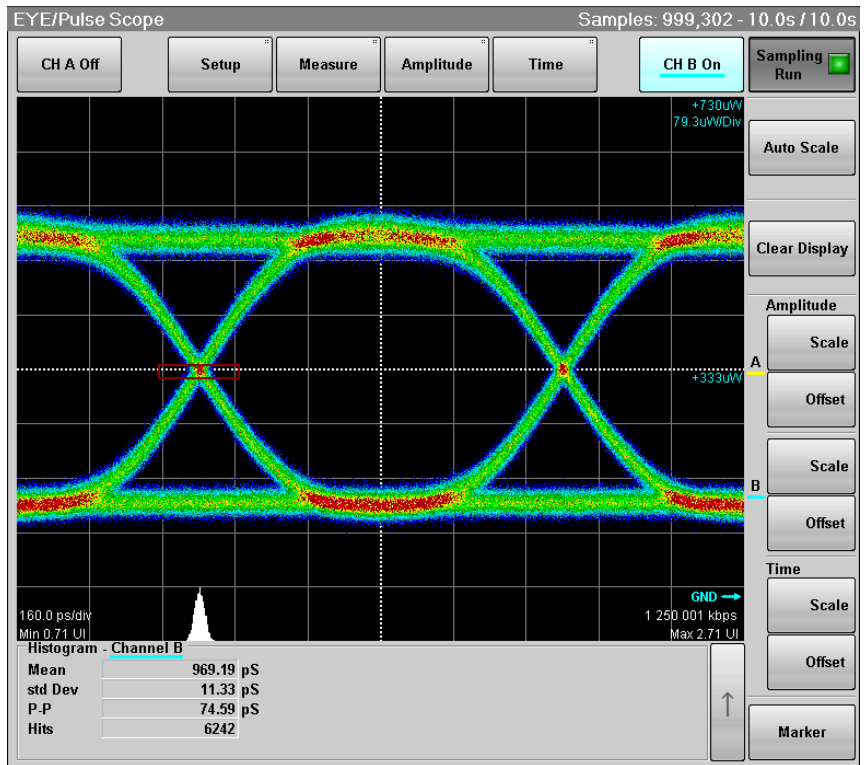

Figure 7.11.2-3 Histogram Measurement Example (Time)

7.11.3 Executing Mask Test

To execute the mask test, first select measurement channel and mask. There are two types of mask tests as follows:

- Set the upper data error count and measure the mask margin.
- Set the mask margin and measure the error data count.

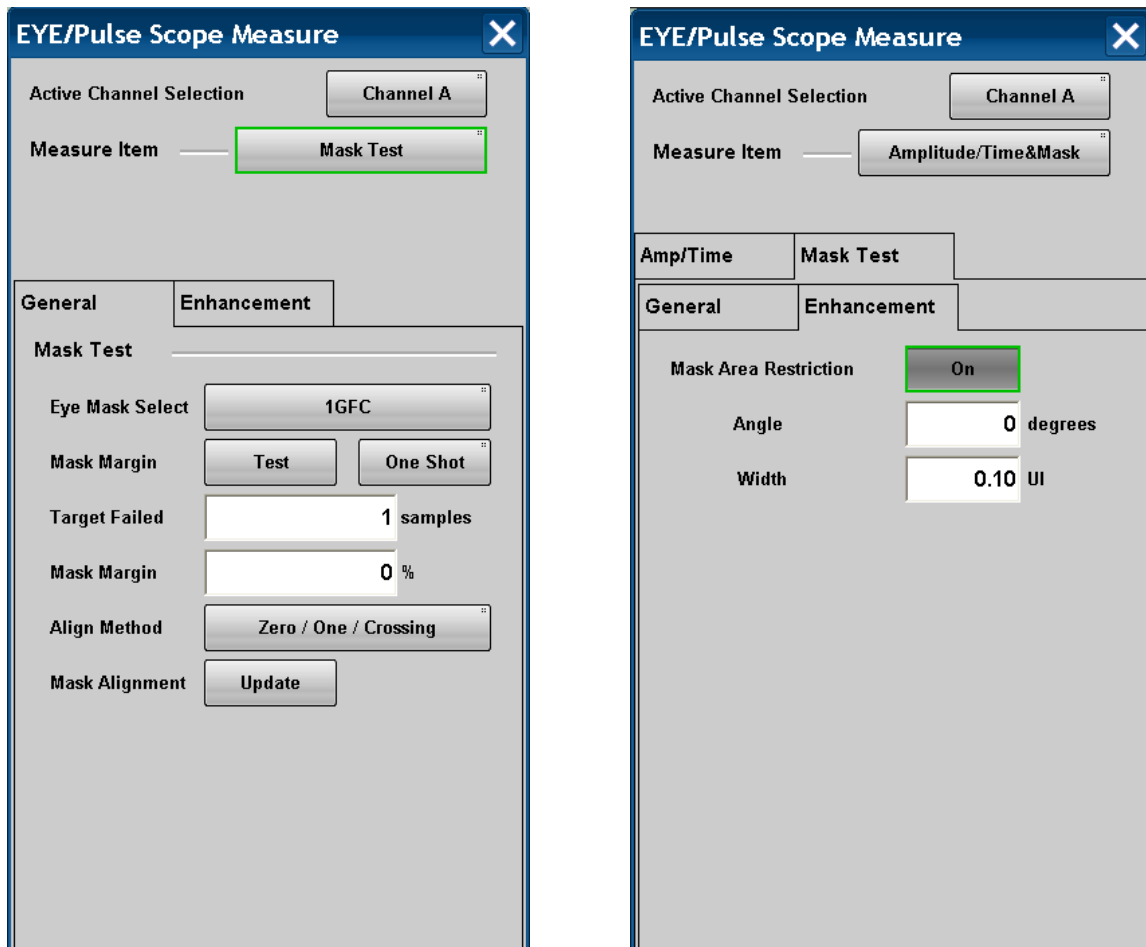

Figure 7.11.3-1 Setting Example of Mask Test

To select channel and mask

1. Touch [Measure] to open the Measure dialog box.
2. Touch the Active Channel Selection button, and then select the channel to be measured.
3. Touch the Measure Item button.
4. Touch [Mask Test] or [Amplitude/Time&Mask].
5. When selecting [Amplitude/Time&Mask], touch the [Mask Test] tab.
6. Touch the [General] tab.
7. Touch the Eye Mask Select button to select the mask.
8. When selecting [User defined], the file selection dialog box is opened. Touch the mask file and [OK].

For more information about the mask file, refer to D.2 “Mask File Specifications”.

The selected mask or mask file is displayed in the [Current Mask] box of the measurement results. Refer to Figure 7.11.3-2 “Mask Test Example”.

Table 7.11.3-1 Mask List

Mask Name	Bit Rate
1GFC	1.0625 Gbit/s
2GFC	2.125 Gbit/s
4GFC	4.25 Gbit/s
8GFC	8.5 Gbit/s
8GFC_Elect_Rx	8.5 Gbit/s
8GFC_Elect_Tx	8.5 Gbit/s
10GFC	10.52 Gbit/s
10GFC FEC	11.3 Gbit/s
1GbE	1.25 Gbit/s
2GbE	2.5 Gbit/s
10GbE_WAN	9.953 Gbit/s
10GbE_LAN/PHY	10.3125 Gbit/s
10GbE_FEC	11.10 Gbit/s
OC48/STM16	2.488 Gbit/s
OC192/STM64	9.953 Gbit/s
OC192/STM64 FEC(G.975)	10.664 Gbit/s
OTU-1	2.666057 Gbit/s
OTU-2 1310nm	10.709 Gbit/s
OTU-2 1310nm	10.709 Gbit/s
OTU-2 1550nm	10.709 Gbit/s
OTU-2 1550nm Expanded	10.709 Gbit/s
User Defined	*

*: This value varies depending on the selected file.

Table 7.11.3-2 Files That Can Be Selected When User Defined Is Selected

File Name	Supported Standard	Bit Rate
10GE-LX4.txt	10G Ethernet LX4	*1
10G_BASE-LRM.txt	10G BASE-LRM	10.3125 Gbit/s
10G_LAN.txt	10 LAN	10.3125 Gbit/s
10xGE.txt	10 x 1 Gbit/s Ethernet	12.5 Gbit/s
100BASE-BX_LX10.txt	100BASE-BX LX10	100 Mbit/s
HDMI_TP1.txt*2 HDMI_TP2.txt*3	HDMI	*1
InfiniBand.txt	InfiniBand	*1
OC12_STM4.txt	OC-12/STM-4	622.08 Mbit/s
OC192_STM64+FEC(G.709).txt	OC-192/STM-64 ITU-T G.709 FEC	10.709 Gbit/s
OC24_STM8.txt	OC-24/STM-8	1.244 Gbit/s
OC3_STM1.txt	OC-3/STM-1	155.52 Mbit/s
OC48_STM16+FEC(G.709).txt	OC-48/STM-16 ITU-T G.709 FEC	2.666 Gbit/s
SATA 1.5Gb TX250 Cyc.txt	SATA 250 Cycle	1.5 Gbit/s
SATA 1.5Gb TX5 Cyc.txt	SATA 5 Cycle	1.5 Gbit/s
XAUI-E Far.txt*4 XAUI-E Near.txt*5	XAUI Extender	*1

*1: Unspecified

*2: Mask file for HDMI transmitter

*3: Mask file for HDMI receiver

*4: Mask file for XAUI Extender Far

*5: Mask file for XAUI Extender Near

To measure mask margin

1. Touch [Setup].
2. Touch the Sampling Mode button to set the display [Eye] or [Coherent Eye].
3. Touch [Sampling] to set the display Run.
4. When the trace is displayed, touch [Auto Scale].
Check that the eye pattern is displayed in the center of the screen.
5. Touch [Measure].
6. Touch the Active Channel Selection button to set the channel.
7. Touch the Measure Item button.
8. Touch [Mask Test] or [Amplitude/Time&Mask].
9. When selecting [Amplitude/Time&Mask], touch the [Mask Test] tab.
10. Touch the [General] tab.
11. Touch the Align Method button to set to [Zero/One/ Crossing].
12. Touch the Target Failed text box.
13. Input the upper limit of the data input to the mask area.
14. When performing the single measurement, touch the button on the right side of Mask Margin and set to [One Shot].
When performing the measurement continuously, touch the button on the right side of Mask Margin and set to [Continuous].
15. Touch [Update].
16. When selecting [One Shot], touch [Test] of Mask Margin to set Sampling to Hold and measure Mask Margin. On the other hand, when selecting [Continuous], set Sampling to Run to measure Mask Margin.

Despite the settings, the mask margin, which number of data inputting the mask area is under the Target Failed value, is measured.

To set Mask Margin and execute mask test

1. Touch [Setup].
2. Touch the Sampling Mode button to set the display [Eye] or [Coherent Eye].
3. Touch [Sampling] to set the display Run.
4. When the trace is displayed, touch [Auto Scale].
Check that the eye pattern is displayed in the center of the screen.
5. Touch [Measure].
6. Touch the Active Channel Selection button to set the channel.
7. Touch [Mask Test].
8. Touch the [Enhancement] tab.
9. Touch the Align Method button to set to [Zero/One/Crossing].
10. Touch the right side button of Mask Margin to set to [One Shot].
11. Touch [Sampling] to set the display to Hold.
12. Touch [Update].
13. Touch the mask margin text box.
14. Input the mask margin in the range of -100 to 100 .
15. The shape of the mask is changed, and the measurement result is displayed on the screen.

Note:

When executing the Mask Test, run Auto Scale to set Bits On Screen to 2.

The Mask Test measured value is assured when Bits On Screen is 2. If Bits On Screen is 3 or more, the optimum Mask position may not be detected because the vertical scale setting is not optimum.

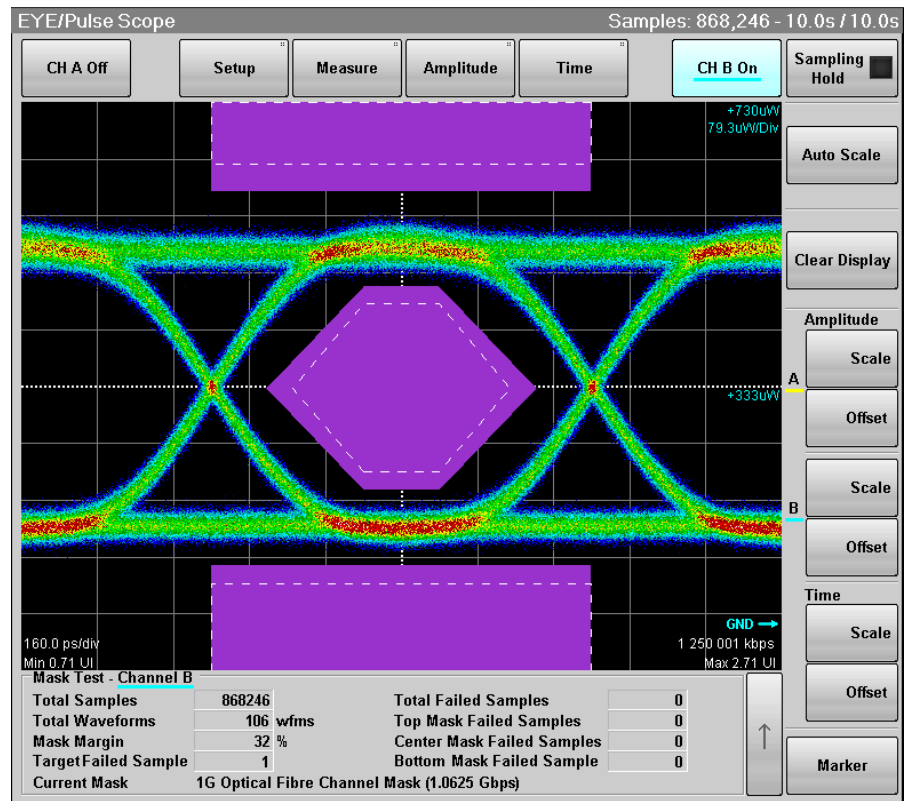

Figure 7.11.3-2 Mask Test Example

The following values are displayed in the measurement result:

- Total Samples: Total data count displayed on the screen
- Total Waveforms: Total waveform count displayed on the screen
- Mask Margin: Mask Margin measurement results or settings
- Target Failed Samples: Data count set to measure Mask Margin
- Total Failed Samples: Total data count within three mask areas
- Top Mask Failed Samples: Data count in top mask area
- Center Mask Failed Samples: Data count in center mask area
- Bottom Mask Failed Samples: Data count in bottom mask area
- Current Mask: Present mask name

Adjusting mask position

To adjust mask position automatically

When Mask Alignment Algorithm is [Zero/One/Crossing], touch the Mask Alignment [Update].

When touching the Mask Alignment [Update], calculate [One/Zero Crossing] of the currently described waveform and optimize the mask position automatically.

The mask position is adjusted automatically if the Scale and Offset on the screen are changed. However, the mask position cannot be changed.

To adjust mask position manually

When Alignment Method is [User Defined], the mask position, width and amplitude can be adjusted using the marker.

1. Touch the right side button of  and set [Display On] to display the marker.

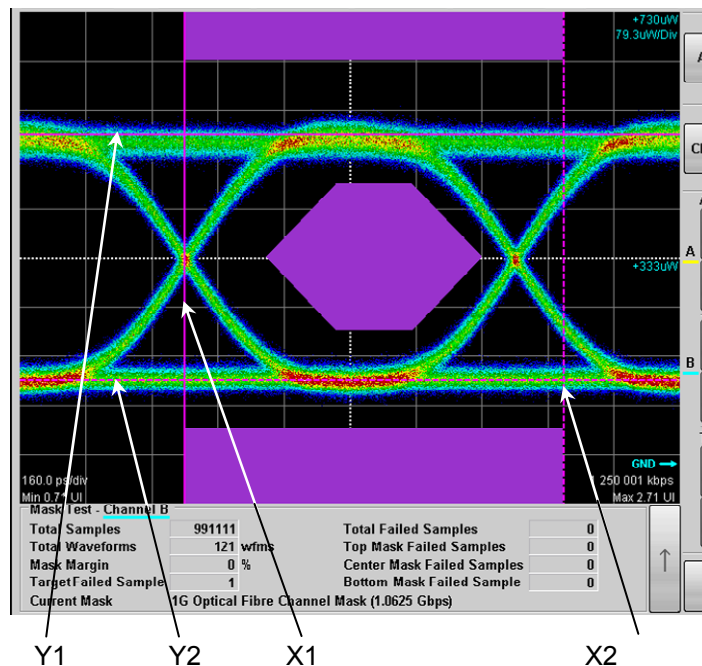

2. Touch the X1 text box to set the mask position.
3. Touch the ΔX text box to set the mask width.
4. Touch the Y1 text box to set the level 1.
5. Touch the ΔY text box to set the level 0.

Touching [Center] moves the marker without depending on the waveforms. In this case, the setting values of X1, ΔX , Y1, and ΔY are initialized.

Although the marker is not displayed at [Display Off], the marker position can be adjusted by changing the value in the text box.

To limit mask area

To examine in which part of the mask at the center the error occurs when the error occurs in the mask test, the mask area can be limited.

Setting width and angle can limit the mask area.

If the mask area is limited, the error that occurs in an upper and lower mask area is not measured.

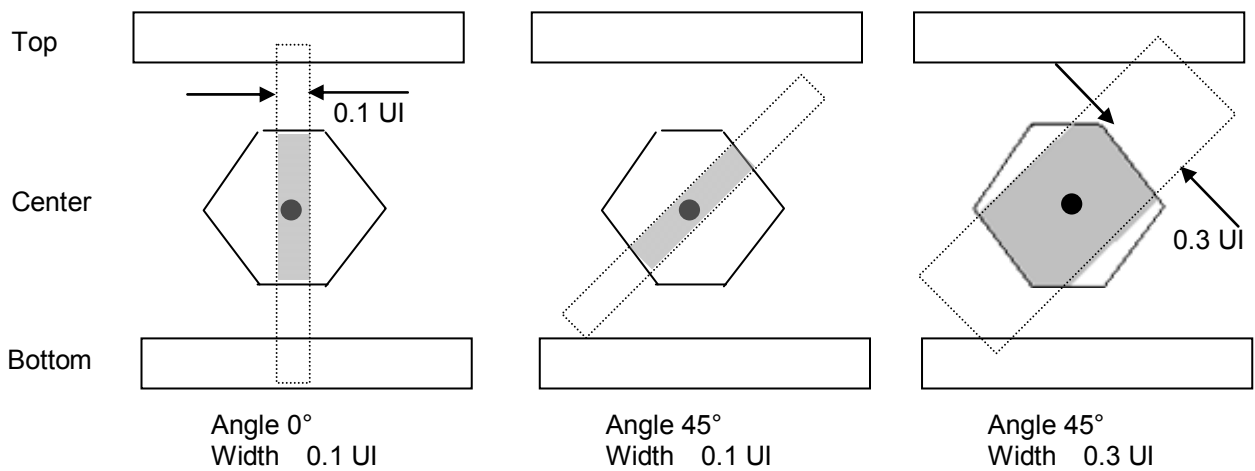

Figure 7.11.3-3 Example of Limiting Mask Area

1. Touch [Measure].
2. Touch the Active Channel Selection button to set the channel.
3. Touch [Mask Test].
4. Touch the [Enhancement] tab.
5. Touch the Mask Area Restriction button to set [On].
6. Touch the [Angle] text box to set the angle within the range of -90 to 90.
7. Touch the [Width] text box to set the width within the range of 0.01 to 1.00.

“Restriction enabled” is displayed in the measurement result display area.

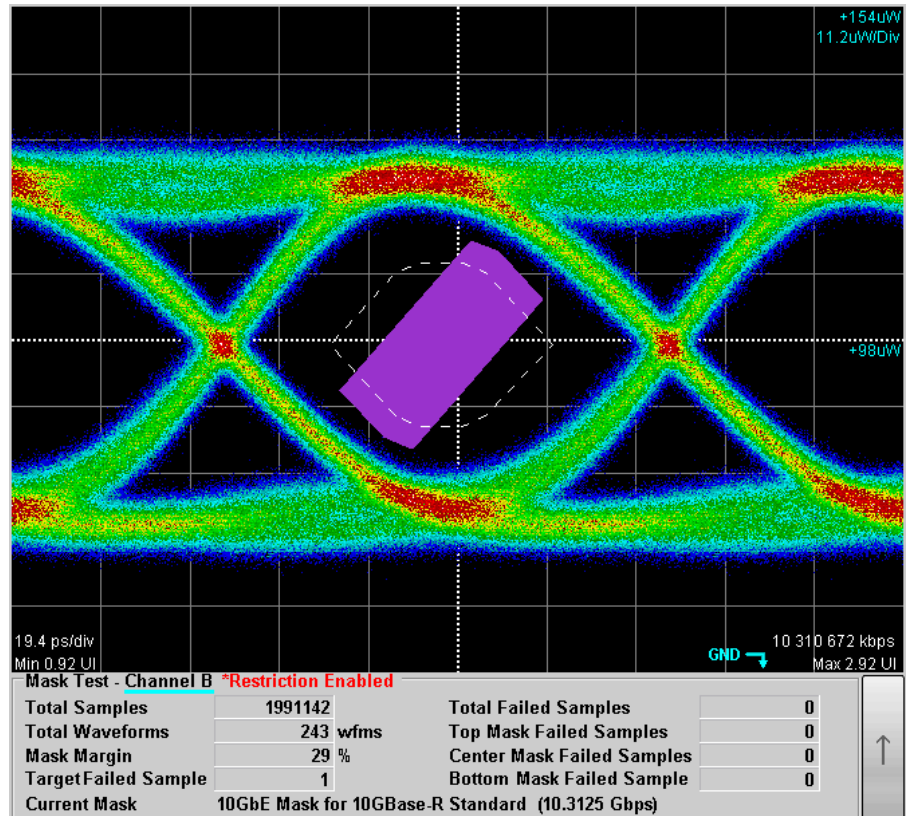

Figure 7.11.3-4 Example of Area Limited Mask Test

7.12 Using Marker

The marker is used to read the amplitude and time values of the waveform.

Also, the level and time differences between two points can be measured.

There are two markers each for the x- and y-axes. Display of each marker can be set to on or off separately.

1. Touch [Marker] to display the marker panel.

The marker panel can be moved in the EYE/Pulse Scope window.

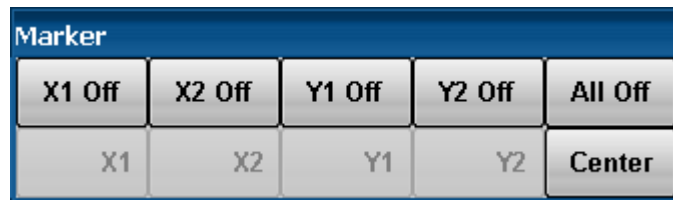

2. To display the marker, touch the upper line buttons other than [All Off].

When the marker is displayed, the lower line buttons are invalid.

3. To move the marker, touch the lower line buttons other than [Center]. The selected marker button is changed to the in-use display, and then the icon is displayed.



4. Set the marker position using the rotary knob. The marker position and time/level differences are displayed.

Marker Panel

X1 Off, X1 On, X2 Off, X2 On, Sets marker display

Y1 Off, Y1 On, Y2 Off, Y2 On

X1, X2, Y1, Y2 Selects marker to be moved

Center Centers marker in the screen

All Off Hide all markers

When the measurement result is displayed, touch [↑] at the left side of [Marker] to switch the marker display.

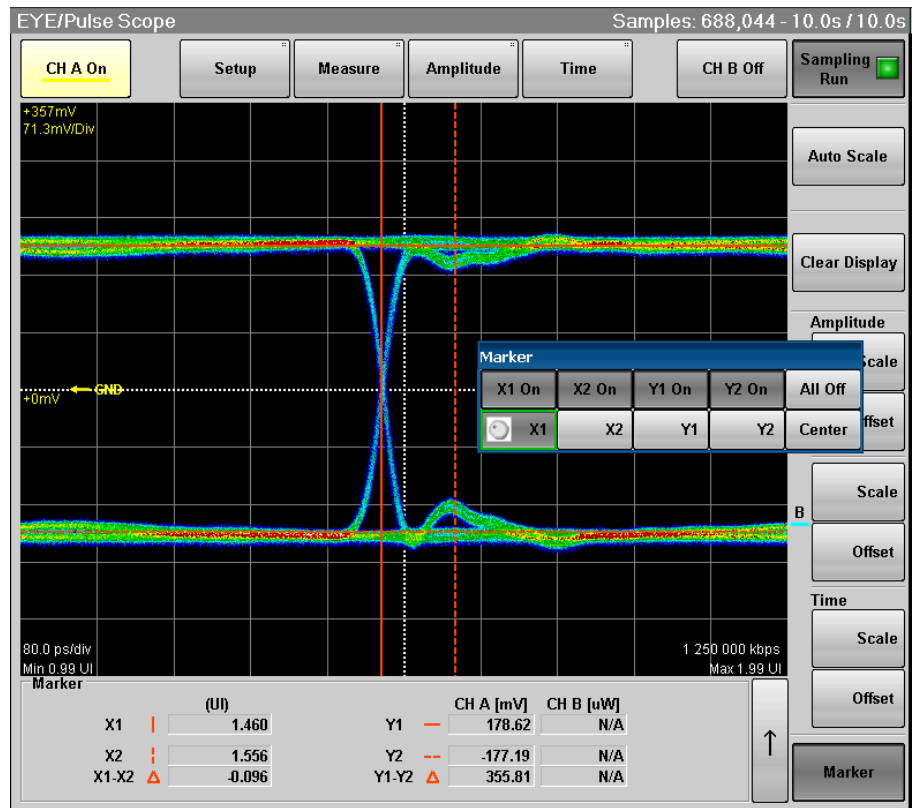

Figure 7.12-1 Marker Display

7.13 Waveform Math Calculation

The calculated math results for the two CH A and CH B waveforms can be displayed as a different waveform. The calculated math results can be measured at Section 7.11 “Measuring Waveform”.

Note:

When calculating the EYE pattern waveform, set Sampling Mode to [Coherent Eye] and collect the data.

If Sampling Mode is set to [Eye] and data is collected, a computational error occurs.

Setting waveform calculation method and vertical scale

1. Touch [Amplitude] to open the Amplitude dialog box.
2. Touch the Channel Math button to set the button display to [On].
3. Touch the Define Function button at Channel Offset.
4. Select the calculation method from the following:
[CH A+CH B]
[CH A-CH B]
[CH B-CH A]

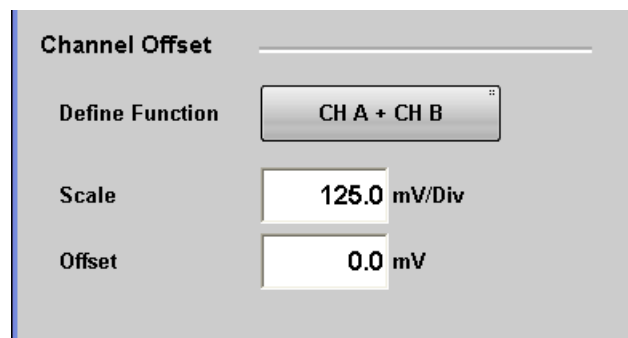

5. Touch the Scale text box at Channel Offset.
6. Input the voltage per vertical scale.
7. Touch the Offset text box at Channel Offset.
8. Input the voltage for the center of the vertical scale.

For the adjustment method of the time axis, refer to 7.10.3 “Adjusting Horizontal-axis of Screen”.

Even when the calculated waveform is displayed, [Auto Scale] can be displayed.

To close the waveform calculation display, touch the Channel Math button and set the button display to [Off].

7.14 Using Trace Memory

The trace memory is a function to save the measurement waveform in the memory.

The waveform saved in the trace memory calls the reference trace.

To save the waveform in the trace memory

1. Touch [Setup] to open the Setup dialog box.
2. Touch the [Utilities] tab.
3. Touch the Ref.Trace Channel button and select the channel to be saved from the following.
 - [Ch A & Ch B]
 - [Ch A]
 - [Ch B]
4. Touch [Set Reference].

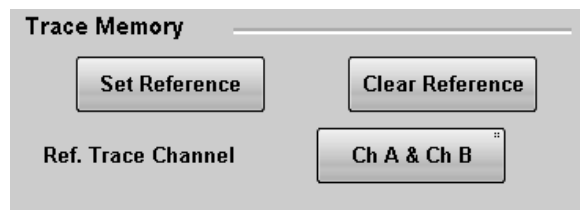

5. The trace waveform is displayed in the screen.

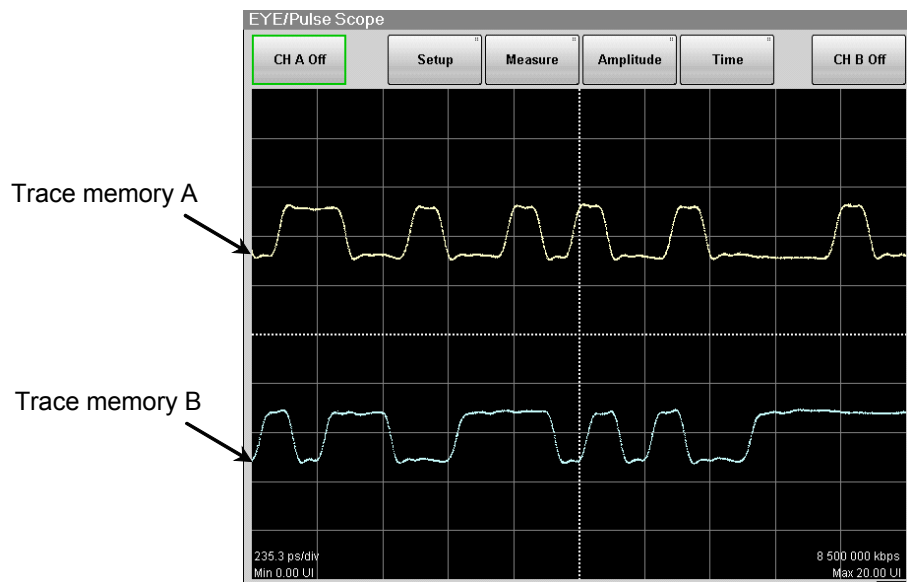

Figure 7.14-1 Waveform Display of Trace Memory

To delete the trace memory waveform

1. Touch [Setup] to open the Setup dialog box.
2. Touch the [Utilities] tab.
3. Touch [Clear Reference] to delete both reference traces in Channel A and B.

7.15 Displaying a Label

This section describes how to display an arbitrary string (label) in the EYE/Pulse Scope screen.

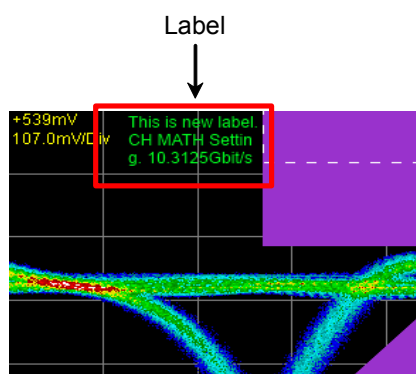

Figure 7.15-1 Label Display

Displaying a label

1. Touch [Setup] to open the Setup dialog box.
2. Touch [Utilities] tab.
3. Touch [Add] for NEW Label, and the software keyboard appears.
4. On the software keyboard, enter a string of up to 1024 characters.
5. Touch [OK] on the software keyboard, and the label is displayed on the screen.

Note:

The location, width and color of the label cannot be changed.

Deleting the displayed label

1. Touch [Setup] to open the Setup dialog box.
2. Touch [Utilities] tab.
3. Touch [Delete] for Delete Label, and the displayed label is deleted.

7.16 Saving Measurement Results

The sampling oscilloscope results can be saved in the following file types:

- Screen image
The waveform display and measurement result display area are saved as a jpeg or png file.
- Measurement result
The waveform is saved as a text file, binary file or CSV file.
- Measurement conditions
The setting values in the Amplitude, Measurement, Setup, and Time dialog boxes are saved to a file.

To save screen image

When saving the entire screen

1. Touch [Screen Copy] at the system menu. The file selection screen is displayed.



2. Touch the Drives button and the Directories field to set the save destination folder. The path to the save folder is displayed at the Save to field.
3. The file format to be saved is displayed in the right button of the file type. Touching the button can set the file format.
4. To set the file name, touch [Screen Keyboard] and input the file name.
5. When overwriting an existing file, touch the file name displayed at File List.

6. Touch [OK] to save the screen image.

When overwriting a file, a confirmation dialog box is displayed.

The path to the default folder is:

C:\Program Files\Anritsu\MP2100A\MX21000A\UserData\Screen Copy

The date and time are recorded in the default file name.

When saving the measurement screen:

1. Touch [Setup].
2. Touch [Utilities].
3. To save both waveform and measurement results as an image, switch the option for Waveforms only to [Off].
To save only the waveform as an image, switch the option for Waveforms only to [On].
4. To save a screenshot using monitor color, set Inverse background color to [Off].

To reverse the screen color, set Inverse background color to [On].

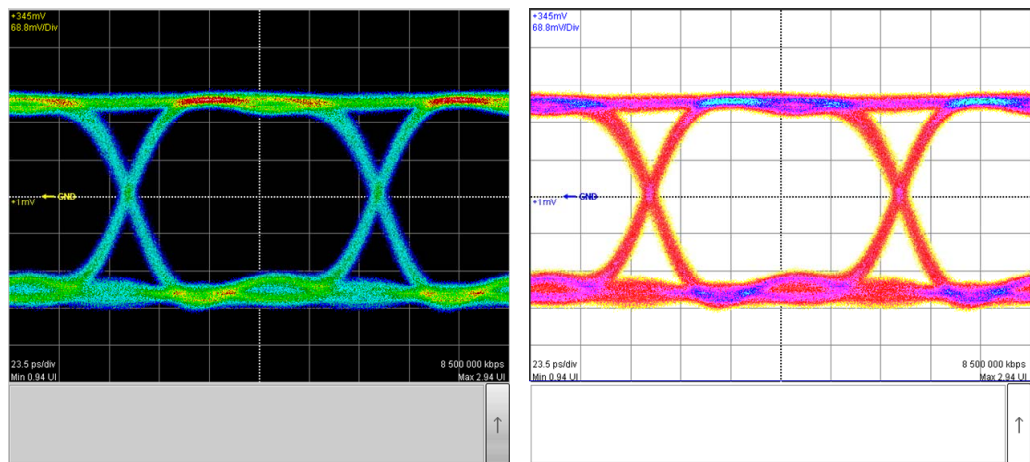

Inverse Off

Inverse On

5. Touch [Capture]. The file selection screen same as the entire screen to be saved is displayed.
6. Set the file format, folder and file name and touch [OK].
7. The image png file is saved in the following path when the folder is set to the default.

C:\Program Files\Anritsu\MP2100A\MX21000A\UserData\Screen Copy

To save measurement condition or measurement result

1. Touch [Save] at the system menu.
2. Touch [EYE/Pulse Scope].
3. When saving the measurement condition, touch [Setting].
When saving the measurement result, touch [Result].
4. Input the file name.
5. Touch [OK] or press the rotary knob.

The measurement condition file is saved in the following folder.

The extension for saved files is WFS.

C:\Program Files\Anritsu\MP2100A\MX21000A\UserData\Setting

The measurement result file is saved in the following folder.

The extension of the measurement data file is CSV and TXT.

C:\Program Files\Anritsu\MP2100A\MX21000A\UserData\Result\CSV

C:\Program Files\Anritsu\MP2100A\MX21000A\UserData\Result\TXT

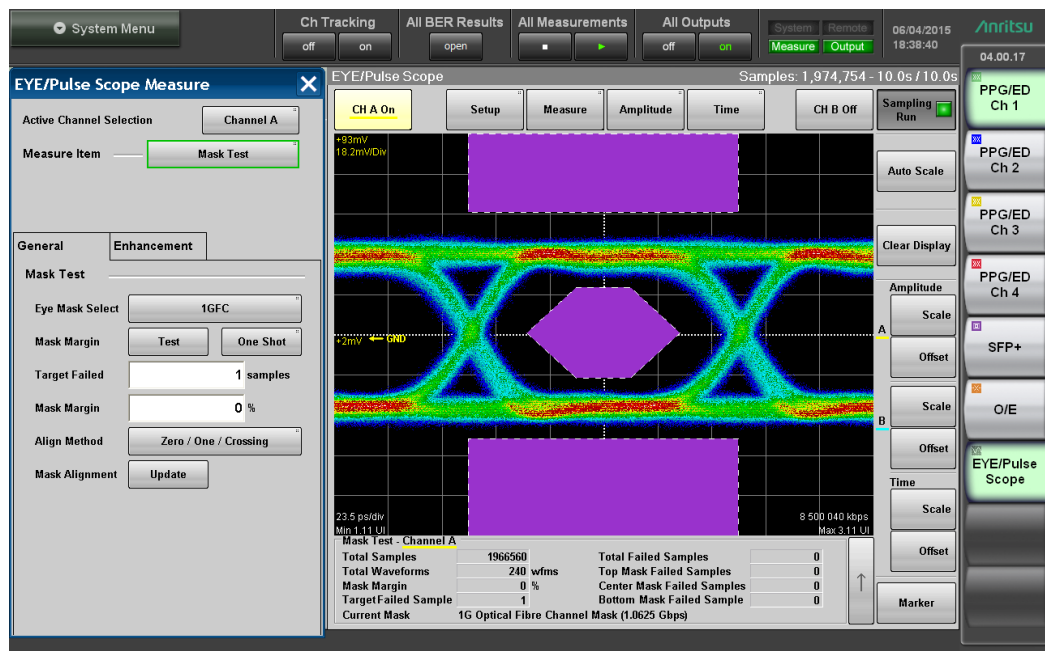

Figure 7.16-1 Example of Image File

The measurement results file saves the number of samples per screen pixel.

```

Amplitude/Time Measurement
[Results]
One Level CH A 192.12 191.80 0.10 191.66 192.12
One Level CH B N/A N/A N/A N/A N/A
Zero Level CH A -185.98 -185.63 0.10 -186.00 -185.43
Zero Level CH B N/A N/A N/A N/A N/A
Eye Amplitude CH A 378.10 377.44 0.19 377.16 378.12
Eye Amplitude CH B N/A N/A N/A N/A N/A
Eye Height CH A 330.00 329.46 0.19 329.13 330.03
Eye Height CH B N/A N/A N/A N/A N/A
Crossing CH A 49.55 50.18 0.24 49.53 50.28
Crossing CH B N/A N/A N/A N/A N/A
SNR CH A 23.58 23.60 0.04 23.52 23.67
SNR CH B N/A N/A N/A N/A N/A
Average Power (dBm) CH A N/A N/A N/A N/A N/A
Average Power (dBm) CH B N/A N/A N/A N/A N/A
Average Power (mW) CH A N/A N/A N/A N/A N/A
Average Power (mW) CH B N/A N/A N/A N/A N/A
Extinction Ratio CH A N/A N/A N/A N/A N/A
Extinction Ratio CH B N/A N/A N/A N/A N/A
Jitter P-P CH A 15.57 12.15 0.99 10.97 15.92
Jitter P-P CH B N/A N/A N/A N/A N/A
Jitter RMS CH A 2.57 1.93 0.13 1.85 2.58
Jitter RMS CH B N/A N/A N/A N/A N/A
Rise Time CH A 23.26 22.94 0.11 22.82 23.31
Rise Time CH B N/A N/A N/A N/A N/A
Fall Time CH A 22.21 22.02 0.07 21.93 22.29
Fall Time CH B N/A N/A N/A N/A N/A
Eye Width CH A 102.34 106.04 0.74 101.99 106.65
Eye Width CH B N/A N/A N/A N/A N/A
DCD CH A 1.80 1.73 0.39 0.75 2.71
DCD CH B N/A N/A N/A N/A N/A
OMA (mW) CH A N/A N/A N/A N/A N/A
OMA (mW) CH B N/A N/A N/A N/A N/A
OMA (dBm) CH A N/A N/A N/A N/A N/A
OMA (dBm) CH B N/A N/A N/A N/A N/A

Waveform
665x497
CH A
0 0 0 0 0 0 0 0 0 0.....(waveform data)
CH B
0 0 0 0 0 0 0 0 0 0.....(waveform data)

```

Figure 7.16-3 File Example of Amplitude/Time Measurement Data

Amplitude/Time and Mask Measurement - Channel A
[Setups]
Current Mask 1G Optical Fibre Channel Mask (1.0625 Gbps)
[Results]
One Level CH A 189.37 189.71 0.20 189.32 190.04
One Level CH B N/A N/A N/A N/A N/A
Zero Level CH A -185.00 -185.35 0.20 -185.73 -184.89
Zero Level CH B N/A N/A N/A N/A N/A
Eye Amplitude CH A 374.37 375.07 0.39 374.21 375.73
Eye Amplitude CH B N/A N/A N/A N/A N/A
Eye Height CH A 326.99 327.54 0.37 326.40 328.27
Eye Height CH B N/A N/A N/A N/A N/A
Crossing CH A 49.89 49.82 0.16 49.47 50.66
Crossing CH B N/A N/A N/A N/A N/A
SNR CH A 23.70 23.67 0.04 23.12 23.79
SNR CH B N/A N/A N/A N/A N/A
Average Power (dBm) CH A N/A N/A N/A N/A N/A
Average Power (dBm) CH B N/A N/A N/A N/A N/A
Average Power (mW) CH A N/A N/A N/A N/A N/A
Average Power (mW) CH B N/A N/A N/A N/A N/A
Extinction Ratio CH A N/A N/A N/A N/A N/A
Extinction Ratio CH B N/A N/A N/A N/A N/A
Jitter P-P CH A 11.32 11.62 0.90 7.78 14.86
Jitter P-P CH B N/A N/A N/A N/A N/A
Jitter RMS CH A 1.86 1.86 0.06 1.74 2.19
Jitter RMS CH B N/A N/A N/A N/A N/A
Rise Time CH A 35.24 31.12 5.85 22.66 35.68
Rise Time CH B N/A N/A N/A N/A N/A
Fall Time CH A 33.30 29.38 5.39 21.53 33.50
Fall Time CH B N/A N/A N/A N/A N/A
Eye Width CH A 106.78 106.48 0.40 104.43 107.24
Eye Width CH B N/A N/A N/A N/A N/A
DCD CH A 1.50 1.04 0.42 0.00 2.26
DCD CH B N/A N/A N/A N/A N/A
OMA (mW) CH A N/A N/A N/A N/A N/A
OMA (mW) CH B N/A N/A N/A N/A N/A
OMA (dBm) CH A N/A N/A N/A N/A N/A
OMA (dBm) CH B N/A N/A N/A N/A N/A
Total Samples 974729
Total Waveforms 119
Mask Margin 0
Target Failed Samples 1
Total Failed Samples 0
Top Mask Failed Samples 0
Center Mask Failed Samples 0
Bottom Mask Failed Samples 0

Waveform
665x497
CH A
0 0 0 0 0 0 0 0 0 0 0.....(waveform data)
CH B
0 0 0 0 0 0 0 0 0 0 0.....(waveform data)

Figure 7.16-4 File Example of Amplitude/Time&Mask Measurement Data

```

Amplitude/Time and Histogram Measurement - Channel A
[Setups]
Axis Time
X1 Marker 0.50UI
X2 Marker 1.50UI
Y1 Marker 9mV
Y2 Marker -10mV
[Results]
One Level CH A 189.65 189.84 0.13 189.60 190.04
One Level CH B N/A N/A N/A N/A N/A
Zero Level CH A -185.34 -185.48 0.14 -185.73 -185.12
Zero Level CH B N/A N/A N/A N/A N/A
Eye Amplitude CH A 374.99 375.31 0.26 374.72 375.73
Eye Amplitude CH B N/A N/A N/A N/A N/A
Eye Height CH A 327.54 327.74 0.27 326.40 328.27
Eye Height CH B N/A N/A N/A N/A N/A
Crossing CH A 49.89 49.82 0.17 49.47 50.66
Crossing CH B N/A N/A N/A N/A N/A
SNR CH A 23.71 23.67 0.04 23.12 23.76
SNR CH B N/A N/A N/A N/A N/A
Average Power (dBm) CH A N/A N/A N/A N/A N/A
Average Power (dBm) CH B N/A N/A N/A N/A N/A
Average Power (mW) CH A N/A N/A N/A N/A N/A
Average Power (mW) CH B N/A N/A N/A N/A N/A
Extinction Ratio CH A N/A N/A N/A N/A N/A
Extinction Ratio CH B N/A N/A N/A N/A N/A
Jitter P-P CH A 11.68 11.71 0.84 7.78 14.86
Jitter P-P CH B N/A N/A N/A N/A N/A
Jitter RMS CH A 1.83 1.87 0.07 1.77 2.19
Jitter RMS CH B N/A N/A N/A N/A N/A
Rise Time CH A 35.16 27.11 5.94 22.66 35.68
Rise Time CH B N/A N/A N/A N/A N/A
Fall Time CH A 33.16 25.65 5.45 21.53 33.50
Fall Time CH B N/A N/A N/A N/A N/A
Eye Width CH A 106.25 106.41 0.46 104.43 107.01
Eye Width CH B N/A N/A N/A N/A N/A
DCD CH A 1.80 1.06 0.45 0.00 2.11
DCD CH B N/A N/A N/A N/A N/A
OMA (mW) CH A N/A N/A N/A N/A N/A
OMA (mW) CH B N/A N/A N/A N/A N/A
OMA (dBm) CH A N/A N/A N/A N/A N/A
OMA (dBm) CH B N/A N/A N/A N/A N/A
Mean 100.62
Std Dev 1.87
P-P 11.68
Hits 3835
Hit Point Detail
0.50UI 0 Hits
0.50UI 0 Hits
0.51UI 0 Hits
0.51UI 0 Hits
0.51UI 0 Hits
:
:
(Hit Point data)

Waveform
665x497
CH A
0 0 0 0 0 0 0 0 0 0 0.....(waveform data)
CH B
0 0 0 0 0 0 0 0 0 0 0.....(waveform data)
    
```

Figure 7.16-5 File Example of Amplitude/Time&HistogramMeasurement Data

```
Histogram Measurement - Channel A
[Setups]
Axis Amplitude
X1 Marker 0.73UI
X2 Marker 0.75UI
Y1 Marker 287mV
Y2 Marker -276mV
[Results]
Mean 5.27
Std Dev 188.49
P-P 423.91
Hits 11979
Hit Point Detail
287mV 0 Hits
284mV 0 Hits
281mV 0 Hits
279mV 0 Hits
276mV 0 Hits
273mV 0 Hits
270mV 0 Hits
268mV 0 Hits
:
:
(Hit Point data)

Waveform
665x497
CH A
0 0 0 0 0 0 0 0 0 0 0.....(waveform data)
CH B
0 0 0 0 0 0 0 0 0 0 0.....(waveform data)
```

Figure 7.16-6 File Example of Histogram Measurement Data

```
Mask Measurement - Channel A
[Setups]
Current Mask 8G Optical Fibre Channel Mask (8.5 Gbps)
[Results]
Total Samples 991111
Total Waveforms 121
Mask Margin 0
Target Failed Samples 1
Total Failed Samples 0
Top Mask Failed Samples 0
Center Mask Failed Samples 0
Bottom Mask Failed Samples 0

Waveform
665x497
CH A
0 0 0 0 0 0 0 0 0 0 0.....(waveform data)
CH B
0 0 0 0 0 0 0 0 0 0 0.....(waveform data)
```

Figure 7.16-7 File Example of Mask Measurement Data

Chapter 8 *Operating Optical Interface*

This chapter explains how to use the optical interface option.

8.1	Optical Interface Types	8-2
8.2	Operating Optical Transceiver	8-5
8.2.1	Function List	8-5
8.2.2	Optical Transceiver Types.....	8-6
8.2.3	Connecting Panel Connector and Optical Transceiver	8-6
8.3	Operating O/E Converter	8-7
8.3.1	Function List	8-7
8.3.2	Calibrating O/E Module	8-12
8.3.3	Adjusting values for changing the wavelength bands	8-12

8.1 Optical Interface Types

The following optical interface types are available.

- O/E converter
- Optical transceiver (SFP+)

O/E Converter

The O/E converter configured by the wide bandwidth photo diode and amplifier can convert the optical signal to the electrical signal.

The block diagram for the O/E converter included in the Option 023 is as follows, and the converted electrical signal is connected internally to the sampling oscilloscope. For details of the low pass filter option numbers, refer to Table 8.3.1-2.

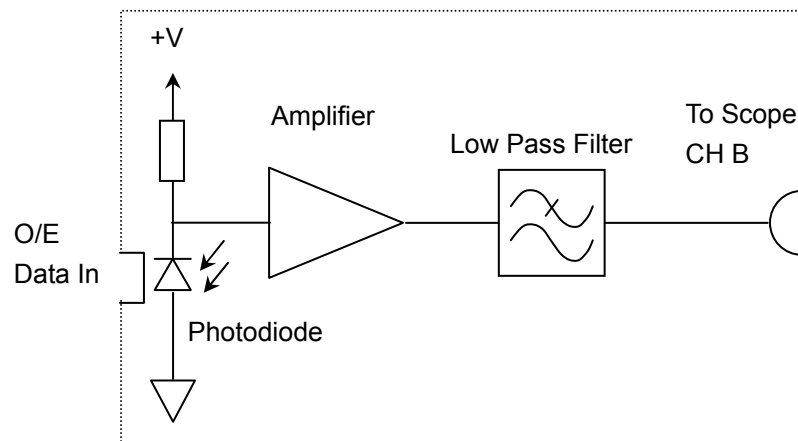

Figure 8.1-1 O/E Converter Block Diagram

Here, the conversion efficiency means the ratio that the photodiode converts the optical signal to electrical signal. This efficiency varies depending on the wavelength. To measure the optical waveform amplitude correctly, it is necessary to calibrate the conversion efficiency.

CAUTION

The maximum optical power input to the O/E Data In is +2 dBm (1.58 mW). Inputting an optical power exceeding this level risks damaging the internal circuits. Connect the optical attenuator to the O/E Data In when measuring the optical signal exceeding +2 dBm.

Optical Transceiver (SFP+)

Optical transceivers combine the following two functions in one module:

- Tx for converting electrical signal into optical signal for transmission
- Rx for converting optical signal into electrical signal for reception

The format and pin layout of the optical transceiver for communication are standardized by the industry organization. So, just changing the optical transceiver makes the optical interface specifications easily.

An optical transceiver conforming to the SFP or SFP+ standard can be connected to the Option 051. For the references of the optical transceiver, refer to Appendix F “Bibliography”.

The logic circuit is used in the Optical transceiver. This is the different from the O/E converter. The relationship between input signal and output signal is the nonlinearity because the waveform of the optical transceiver is shaped by the logic circuit.

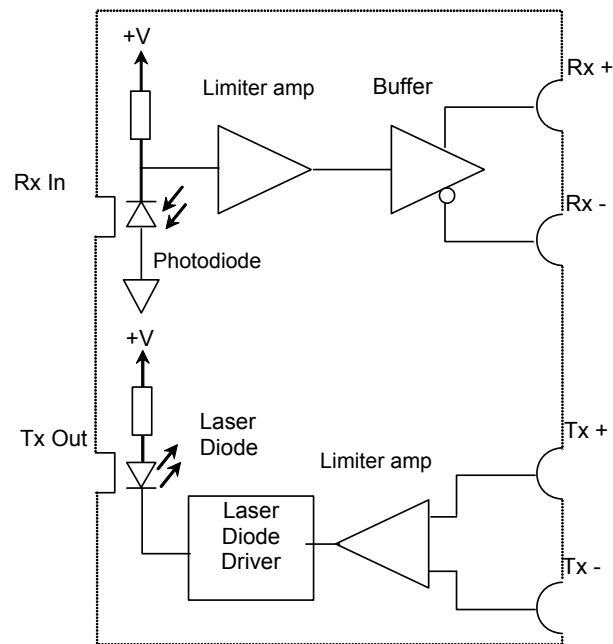

Figure 8.1-2 Optical Transceiver Block Diagram

 **CAUTION**

- Be sure that the optical power input to the Rx of the optical transceiver is the specified max .value or less. Inputting an optical power rather than this power risks damaging the internal circuits.
 - Use the appropriate optical fiber to the optical transceiver. Measurement may not be performed correctly if the optical fiber types (multi-mode fiber, single mode fiber) are not applicable.
 - The impedance of the Tx Data In and Rx Data Out connectors is 50 Ω . Measurement may not be performed correctly if a coaxial cable with another impedance is used or if the impedance of the connected devices is not 50 Ω .
-

8.2 Operating Optical Transceiver

8.2.1 Function list

The following items is set and displayed for the optical transceiver.

Table 8.2.1-1 Optical Transceiver Setting Items and Display Items

Item	Description
Wavelength	Displays wavelength of light output from the optical transceiver. When the recommended optical transceiver is installed, one of the following wavelength is displayed. 850 nm, 1310 nm, 1550 nm
Output	Outputs light to the Tx connector of the Optical transceiver. Touch the Output button, and then the display is changed to ON or Off. The optical output indication is as follows: Green: ON Black: OFF
LOS	Indicates that the light is input to the RX connector of the Optical transceiver. Red: No input light (Loss of signal) Gray: Input light
Ready	Indicates the optical transceiver installed status. Green: Available Black: Optical transceiver not installed or not found

To display the optical transceiver setting screen, touch [SFP+] at the function menu.

The following window appears.

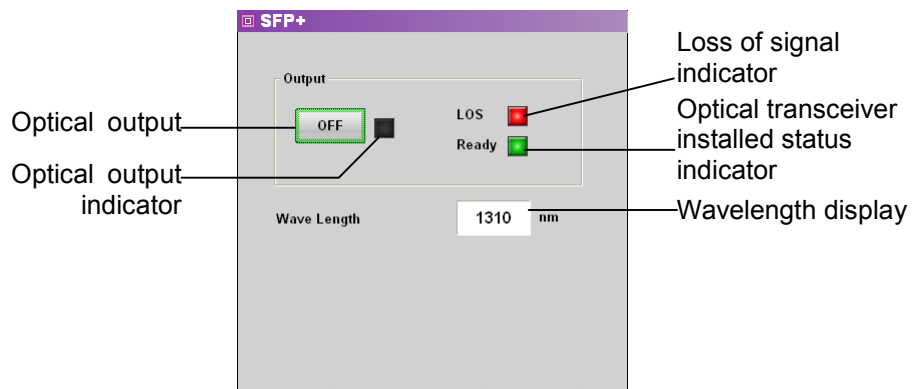

Figure 8.2.1-1 Optical Transceiver Setting Panel (SFP+)

8.2.2 Optical transceiver types

The recommended optical transceivers are listed in Table 8.2.2-1. For the specifications of the optical transceivers, refer to A.2 “Optical Transceiver Module”.

For how to install the optical transceiver, refer to Section 2.8 “Installing Optical Transceiver”.

Table 8.2.2-1 Recommended Optical Transceivers

Model Name	Wavelength (nm)	Appropriate Optical Fiber	Bit Rate (kbit/s)
G0177A	850	MMF	1062000 to 4250000
G0178A	1310	SMF	155200 to 2670000
G0179A	1550	SMF	155200 to 2670000
G0238A	850	MMF	10312500
G0239A	1310	SMF	9953280 to 10312500

8.2.3 Connecting panel connector and optical transceiver

The Tx Data In connector on the front panel connects to the TX+ of the optical transceiver module.

The Rx Data Out connector on the front panel connects to the RX + of the optical transceiver module.

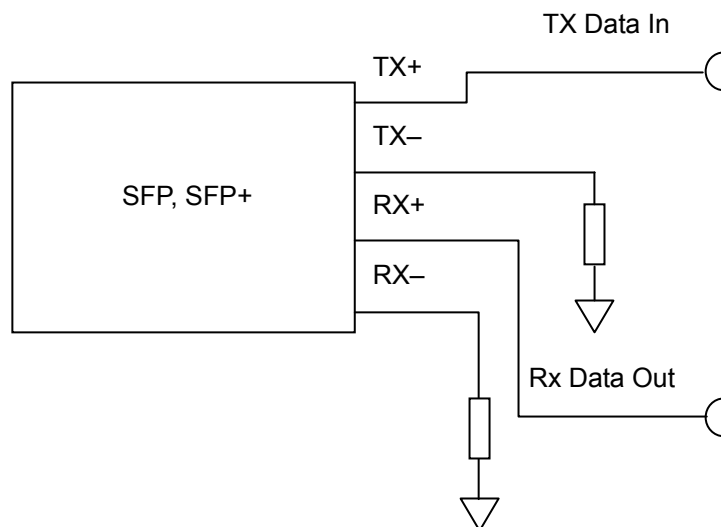

Figure 8.2.3-1 Connection Diagram Between Panel Connector and Optical Transceiver

8.3 Operating O/E Converter

8.3.1 Function list

The following items are set and displayed when installing the O/E converter.

Table 8.3.1-1 O/E Converter Setting Items

Item	Description
Conversion Gain*	Indicates the conversion ratio of the O/E. The setting range is from 1 to 9999 (V/W).
Filter On/Off	When installing the Option 086, the internal low pass filter is set to On/Off.
Filter Selection	Sets the internal low pass filter when one of the Options 063, 065, 069, and 087 to 089 is installed.
Extinction Ratio Correction	Sets whether to correct the Extinction Ratio measurement.
Extinction Ratio Correction Factor	Indicates the correction factor of Extinction Ratio. The setting range is from -9.99 to 9.99%.
O/E Calibration	Starts module calibration.
Responsivity*	Rate at which photodiode converts optical power to current The setting range is from 0.001 to 999.999.
System Conversion Gain*	Indicates the conversion ratio between the power input to the O/E Data In and the voltage displayed on the Result window. It is found from the following formula: System Conversion Gain = $\frac{\text{Conversion gain}}{\text{Measurement internal loss} \times \text{Filter loss}}$ Used for calculating filter loss when one of the Options 070 to 073, 075, 076, 078 to 082, and 086 is added. The loss varies with the filter types.
Wavelength	Select the wavelength of input light from the following: 850 nm, 1310 nm, 1550 nm, User The Responsivity, Conversion Gain, or System Conversion Gain varies depending on the wavelength.
Calibration	Automatically adjusts the Conversion Gain/ Responsivity /System Conversion Gain values. For adjustment, refer to 8.3.3 "Adjusting values for changing the wavelength bands".
Input Power	Setting used when adjusting Conversion Gain/ Responsivity /System Conversion Gain. For adjustment, refer to 8.3.3 "Adjusting values for changing the wavelength bands".

- *: Changes in the setting values of Conversion Gain, Responsivity and System Conversion Gain are not required when measuring an optical signal at a wavelength of 850 nm, 1310 nm or 1550 nm.
For these wavelength bands, calibrated values have been set before shipment from the factory.

To measure an optical signal at the other wavelength than 850 nm, 1310 nm or 1550 nm, change the setting values of Conversion Gain, Responsivity and System Conversion Gain according to the changed wavelength. For how to change the setting values, refer to 8.3.3 “Adjusting values for changing the wavelength bands”.

To display the O/E converter setting screen, touch [O/E] at the function menu.

The screen as shown in Figure 8.3.1-1 is displayed.

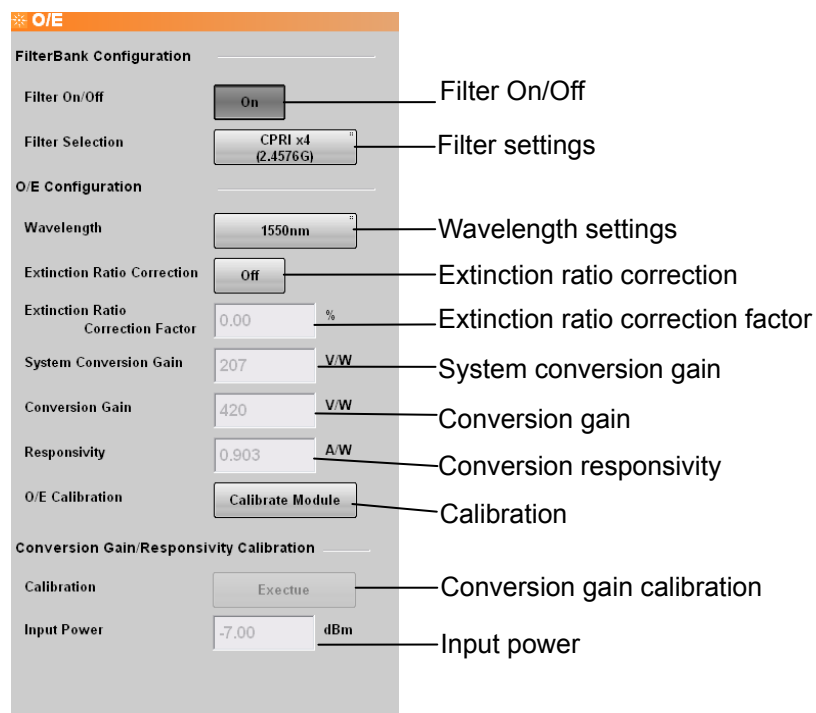

Figure 8.3.1-1 O/E Setting Panel

The setting range of the O/E converter is as follows.

Conversion Gain

1 to 9999 V/W

Extinction Ratio Correction

On

Extinction Ratio Correction Factor

-9.99 to 9.99 %

Filter*1

No Filter

1GFC

2GFC

4GFC

8GFC

10GFC

10GFC FEC

10GFC-LX4

1GbE

2GbE

10GbE FEC

10GbE LAN/PHY

10GbE WAN

10GbE-LX4

CPRI

CPRI×2

CPRI×4

CPRI×5

CPRI×8

CPRI×10

Infiniband

Infiniband×2

Infiniband×4

OC-3/STM-1

OC-12/STM-4

OC-24

OC-48/STM-16

OC-192/STM-64

G975 FEC

OTU-1
OTU-2
XAUI Optical x2
Responsivity
0.001 to 999.999 A/W
Sys Conversion Gain
1 to 7404*² V/W
Wavelength
1310 nm
1550 nm
850 nm
User
Input Power
-2 to -10 dBm

- *1: The filters displayed will vary depending on the option(s) installed. Table 8.3.1-2 Option List shows the option numbers and the names of the filter standards supported by the options
- *2: When installing Option, the upper limit may sometimes be lower than 7404.

Table 8.3.1-2 Option List

Filter	Option*1, *2														
	070	071	072	073	075	076	078	079	080	081	082	086	087	088	089
1GFC			✓												
2GFC						✓									
4GFC									✓				✓	✓	
8GFC												✓	✓	✓	
10GFC												✓	✓	✓	
10GFC FEC												✓	✓	✓	
10GFC-LX4								✓							
1GbE				✓									✓		✓
2GbE					✓								✓		✓
10GbE FEC															
10GbE LAN/PHY												✓	✓	✓	
10GbE WAN												✓	✓	✓	
10GBASE-LX4								✓							
CPRI		✓													
CPRI×2				✓									✓		✓
CPRI×4					✓								✓		✓
CPRI×5								✓							
CPRI×8										✓				✓	
CPRI×10											✓		✓	✓	
Infiniband					✓								✓		✓
Infiniband×2										✓				✓	
Infiniband×4												✓	✓	✓	
OC-3/STM-1	✓														✓
OC-12/STM-4		✓													✓
OC-24				✓										✓	✓
OC-48/STM-16					✓									✓	✓
OC-192/STM-64												✓	✓	✓	
G975 FEC												✓	✓	✓	
OTU-1							✓								
OTU-2												✓	✓	✓	
XAUI Optical x2											✓				

*1: One of the Options 063, 065, and 069 is required for the Options 070 to 076, 078 to 082, and 086.

*2: Filters marked with “✓” can be selected for the installed option numbers.

8.3.2 Calibrating O/E module

When light is not input to the O/E module, the output voltage is adjusted. The output voltage of the O/E module changes depending on the ambient temperature.

Calibrate the BERTWave before using the O/E module.

1. Screw in the O/E Data In cap.
2. Touch [Calibrate Module].
3. The window confirming that the light is not input is displayed. Touch [OK].
4. In about 5 seconds from step 3, the dialog box appears indicating that the calibration is complete. Touch [OK].

8.3.3 Adjusting values for changing the wavelength bands

To measure an optical signal at the other wavelength band than 850 nm, 1310 nm or 1550 nm, adjust the values of Conversion Gain, Responsivity, and System Conversion Gain.

Warm up the O/E module at least one hour because the output voltage varies depending on the ambient temperature. Additionally, be sure to calibrate the sampling oscilloscope before performing adjustment.

<Adjusting Manually>

Adjustment method of Conversion Gain (System Conversion Gain)

1. Adjust the wavelength of the optical power meter to the optical signal.
2. Measure unmodulated optical signal power with the optical power meter.
3. Input the optical signal to the optical input connector.
4. Measure the average of the optical signal power by using the Histogram function of the sampling oscilloscope.
5. Display the O/E setting panel.
6. Set Wavelength to User.
7. Adjust the Conversion Gain value so that the average of the optical signal power measured by the Histogram function of the sampling oscilloscope becomes equal to the value measured by the power meter. The System Conversion Gain value is automatically set by setting the Conversion Gain value.

Adjustment method of Responsivity

1. Adjust the wavelength of the optical power meter to the optical signal.
2. Measure unmodulated optical signal power with the optical power meter.
3. Input the optical signal to the optical input connector.
4. Measure the Average Power (mW) or Average Power (dBm) of the optical signal by using the Amplitude/Time function of the sampling oscilloscope.
5. Display the O/E setting panel.
6. Set Wavelength to User.
7. Adjust the Responsivity value so that the Average Power value of the optical signal measured by the Amplitude/Time function of the sampling oscilloscope becomes equal to the value measured by the optical power meter.

<Adjusting Automatically by Auto Correction>

1. Adjust the wavelength of the optical power meter to that of the optical signal.
2. Measure unmodulated optical signal power with the optical power meter.
3. Input the optical signal to the optical input connector.
4. Display the O/E setting panel.
5. Set Wavelength to User.
6. Set the Input Power to the value of the optical signal power measured by Step 2.
7. Press [Execute] to calibrate automatically.
8. When Auto Correction is completed, the values of Conversion Gain, Responsivity, and System Conversion Gain are adjusted so that they become equal to the values measured by the optical power meter.

Chapter 9 Performance Test

This chapter describes how to test the performance of the BERTWave.

9.1	Performance Test for Pulse Pattern Generator	9-2
9.1.1	Required equipment	9-2
9.1.2	Frequency accuracy	9-2
9.1.3	Waveform	9-4
9.2	Performance Test for Error Detector	9-8
9.2.1	Required equipment	9-8
9.2.2	Operating frequency	9-9
9.2.3	Rx sensitivity	9-14
9.2.4	Maximum input level and patterns	9-16
9.2.5	Error detection	9-19
9.3	Performance Test for Sampling Oscilloscope	9-21
9.3.1	Required equipment	9-21
9.3.2	Amplitude accuracy	9-22
9.4	Performance Test for Optical Interface (O/E Converter)	9-25
9.4.1	Required equipment	9-25
9.4.2	Optical Power Meter	9-26

9.1 Performance Test for Pulse Pattern Generator

This section describes the performance test items for the pulse pattern generator.

- Operation frequency range
- Frequency accuracy

 **CAUTION**

Connect a 50 Ω terminator to unused input/output connectors.

9.1.1 Required equipment

The following table shows the equipment required for the performance test.

Before starting performance tests, warm up the BERTWave and the measuring instruments for at least 1 hour.

Table 9.1.1-1 Equipment for Performance Test

Product Name	Required Performance	Recommended Equipment
Sampling oscilloscope	Electrical interface Bandwidth: 20 GHz or more	MP2100B (Anritsu)
Frequency counter	Frequency range: 500 MHz to 20 GHz Accuracy: 0.1 ppm max.	MF2412C (Anritsu)

9.1.2 Frequency accuracy

- (1) Specification
±10 ppm (One hour after power on)

(2) Setup

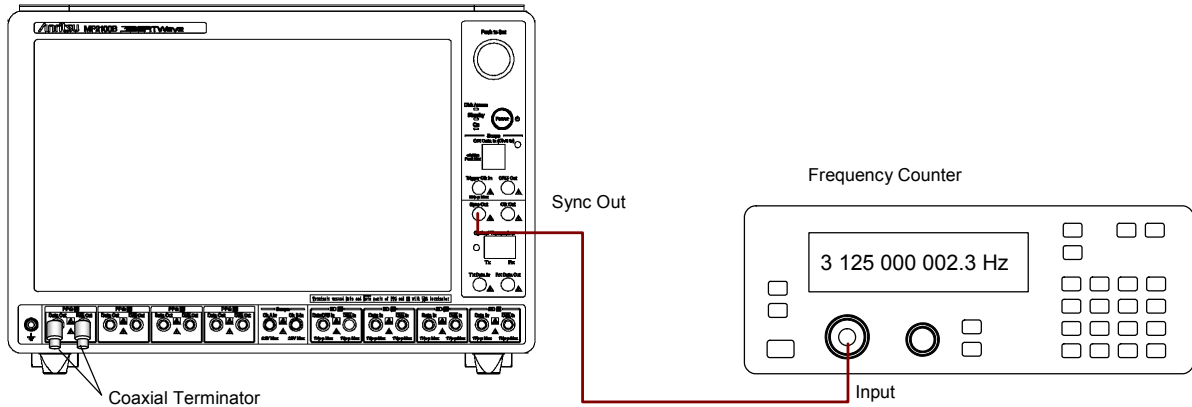

Figure 9.1.2-1 Operation Frequency Range Test Setup

(3) Procedure

1. Connect the Sync Output connector to the input connector of the frequency counter.
2. Connect coaxial terminators to the PPG1 **Data Out** and PPG1 **Data Out** connectors.
3. Touch [PPG/ED1 Ch1].
4. Set Sync Output to [PPG1_1/4 Clk].
5. Set Reference Clock to [Internal].
6. Select [Variable] at Bit Rate and input 11320000 kbit/s.
When the Option 092 is added, input 12500000 kbit/s.
7. Set [Offset] at Bit Rate to 0 ppm.
8. Set Data/XData to [On].
9. Read the setting value of the frequency counter.
10. Check that the read value multiplied by 4 is within the following range.

Without the Option 092:	11320000±113.2 kHz
With the Option 092:	12500000±125 kHz
11. Set Bit Rate to 132813 kbit/s.
When the Option 092 is added, input 125000 kbit/s.
12. Set Sync Output to [PPG1_1/1 Clk].
13. Read the value measured by the frequency counter.
14. Check that the read value is within the following limited values.

Without the Option 092:	132813±1.328 kHz
With the Option 092:	125000±1.25 kHz

9.1.3 Waveform

(1) Specification

- Amplitude: 0.1 to 0.8 Vp-p
- Accuracy: ($\pm 20\%$ of setting) ± 20 mV
- Data Crossing: $50 \pm 10\%$
(Amplitude: 0.8 Vp-p, Bit rate: 11.32 Gbit/s (12.5 Gbit/s when with the Option 092))
- Rise/fall time: 28 ps
(Amplitude: 0.8 Vp-p, Percentage: 20-80%, Bit rate: 11.32 Gbit/s (12.5 Gbit/s when with the Option 092))
- Jitter (RMS): 2 ps (Amplitude 0.4 Vp-p, 10.3125 Gbit/s)

(2) Setup

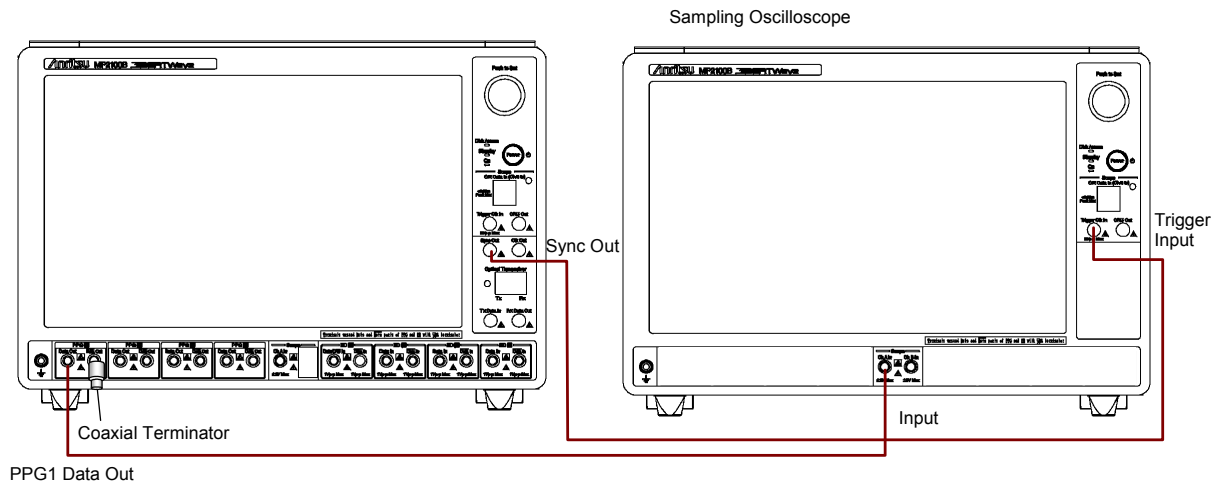

Figure 9.1.3-1 PPG1 Data Out Waveform Test Connection Diagram

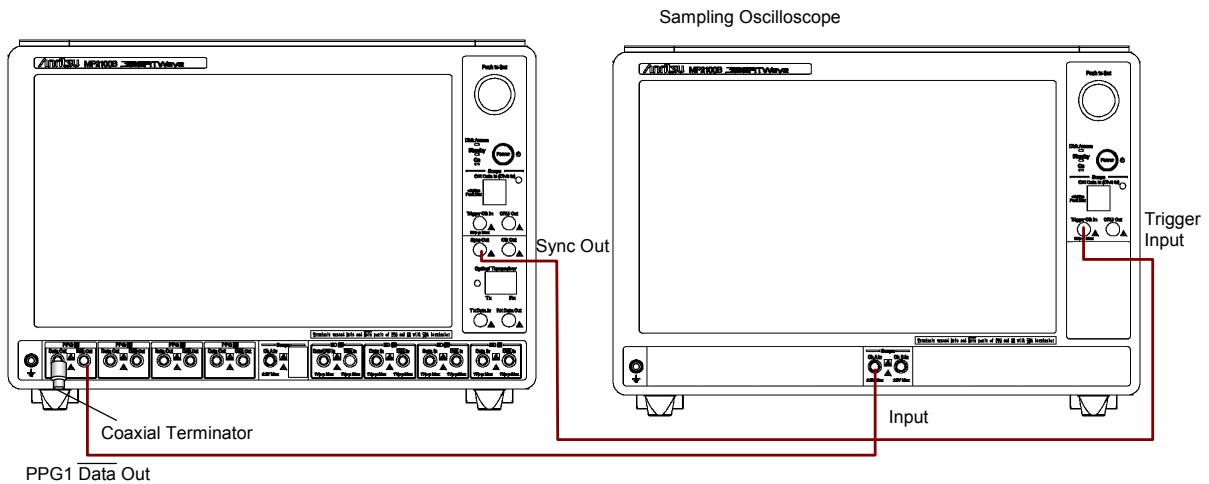

Figure 9.1.3-2 PPG1 Data Out Waveform Test Connection Diagram

(3) Procedure

1. Connect the coaxial terminator to the PPG1 Data Out connector. (Refer to Figure 9.1.3-1.)
2. Connect the Sync Output connector and the trigger input connector of the sampling oscilloscope using a coaxial cable.
3. Connect the PPG1 Data Out connector and the input connector of the sampling oscilloscope using a coaxial cable.
4. Touch [PPG/ED Ch1].
5. Connect Sync Output to [PPG1_1/4 Clk].
6. Set Reference Clock to [Internal].
7. Select [Variable] at Bit Rate and input 11320000 kbit/s. Input 12500000 kbit/s if the Option 092 is added.
8. Set External Attenuation to 0 dB.
9. Set Test Pattern to [PRBS 2³¹-1].
10. Set Data/XData to [On].
11. Set Amplitude to 0.1 Vp-p.
12. Measure the amplitude on the sampling oscilloscope.
13. Set Amplitude to 0.8 Vp-p.
14. Measure the amplitude, rise/fall time, and Data Crossing on the sampling oscilloscope.
15. Set Amplitude to 0.8 Vp-p.
16. Select [Variable] for Bit Rate, and input 11320000 kbit/s.
17. Measure the Jitter (RMS) on the sampling oscilloscope.
18. Connect the coaxial terminator to the PPG1 Data Out connector. (Refer to Figure 9.1.3-2.)

19. Connect the PPG1 **Data Out** connector to the input connector of the sampling oscilloscope.
20. Repeat steps 11 to 14.

PPG2 can be tested in the same way with the Option 012. The connection diagram is as follows.

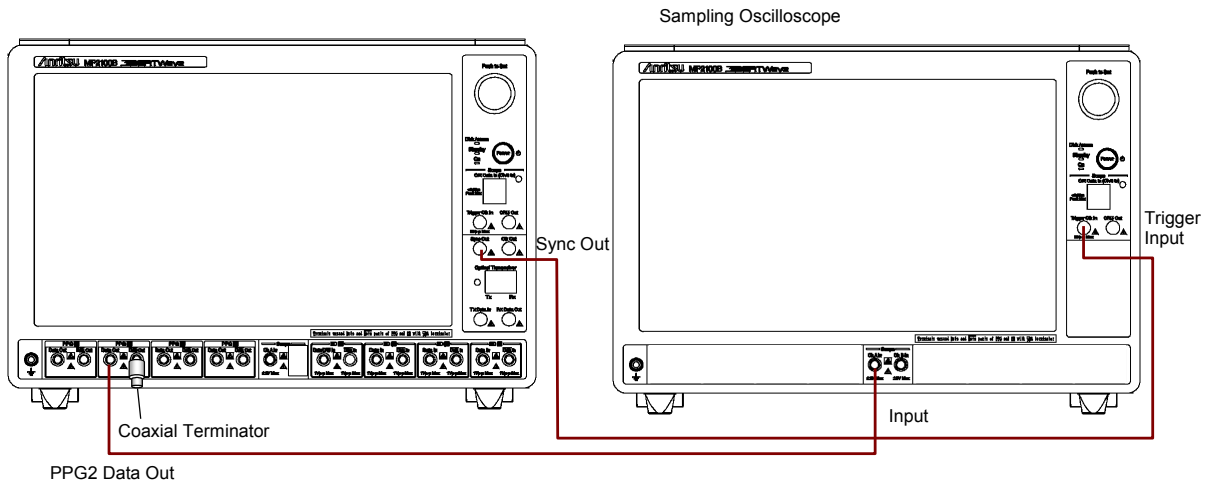

Figure 9.1.3-3 PPG2 Data Out Waveform Test Connection Diagram

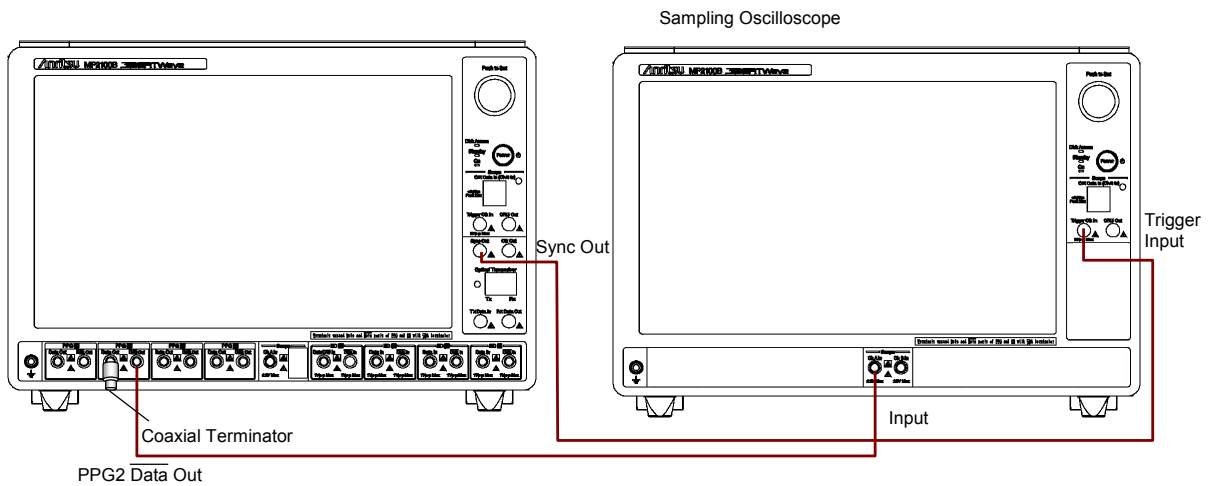

Figure 9.1.3-4 PPG2 Data Out Waveform Test Connection Diagram

ED3 and ED4 can be tested in the same way with the Option 014. The connection diagram for measuring the ED3 input level is as follows.

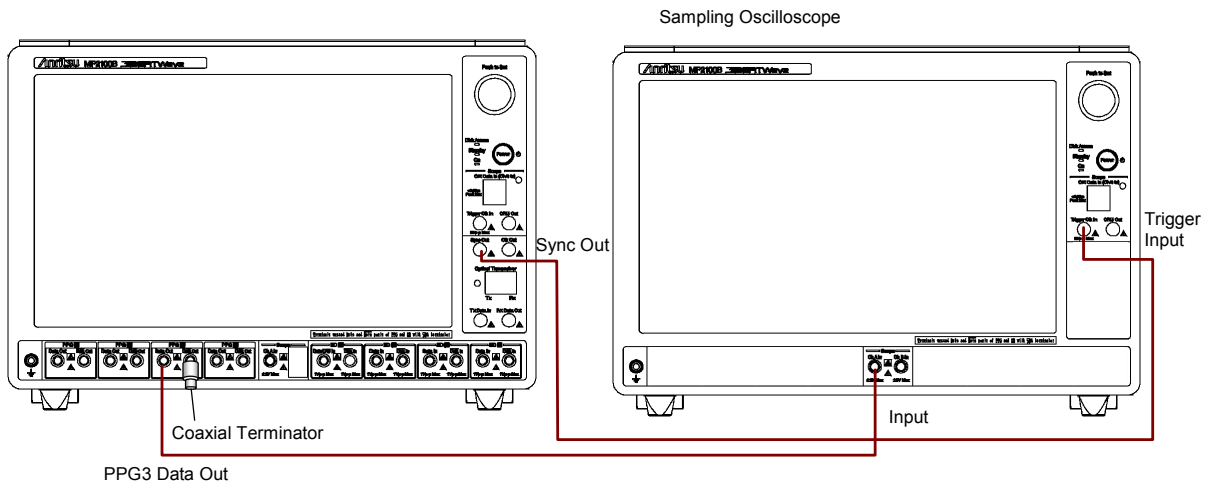

Figure 9.1.3-5 PPG3 Data Out Waveform Test Connection Diagram

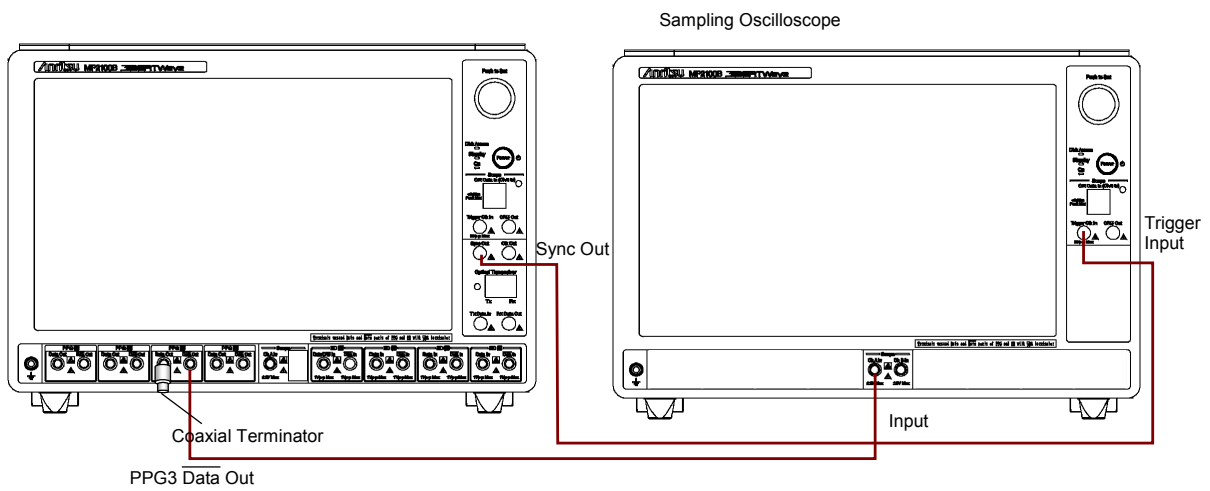

Figure 9.1.3-6 PPG3 Data Out Waveform Test Connection Diagram

9.2 Performance Test for Error Detector

This section describes the performance test items for the error detector.

- Operating frequency
- Rx sensitivity
- Maximum input level and patterns
- Error detection

Before testing the performance of the ED, confirm that the performance of the tested pulse pattern generator satisfies the specifications.

9.2.1 Required equipment

The following table shows the equipment required for the performance test.

Before starting performance tests, warm up the BERTWave and the measuring instruments for at least 1 hour.

Table 9.2.1-1 Equipment for Performance Test

Product Name	Required Performance	Recommended Equipment
Sampling oscilloscope	Electrical interface Bandwidth: 20 GHz or more	MP2100B (Anritsu)
Fixed attenuator	20 dB SMA connector	41KC-20 (Anritsu)

9.2.2 Operating frequency

(1) Specification

0.05 to 0.8 Vp-p

BER 10^{-12} or less under the following conditions:

- Pattern: PRBS31
- Mark ratio: 50%
- Single-end
- Back-to-back connection

Without the Option 092: 132.813 Mbit/s to 11.32 Gbit/s

With the Option 092: 125 Mbit/s to 12.5 Gbit/s

(2) Setup

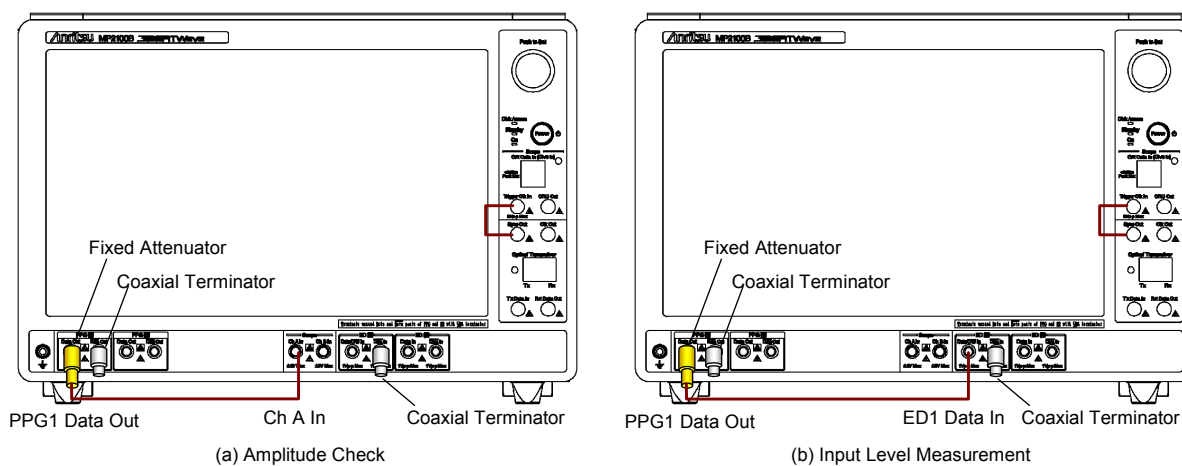

Figure 9.2.2-1 ED1 Data In Input Sensitivity Test Connection Diagram

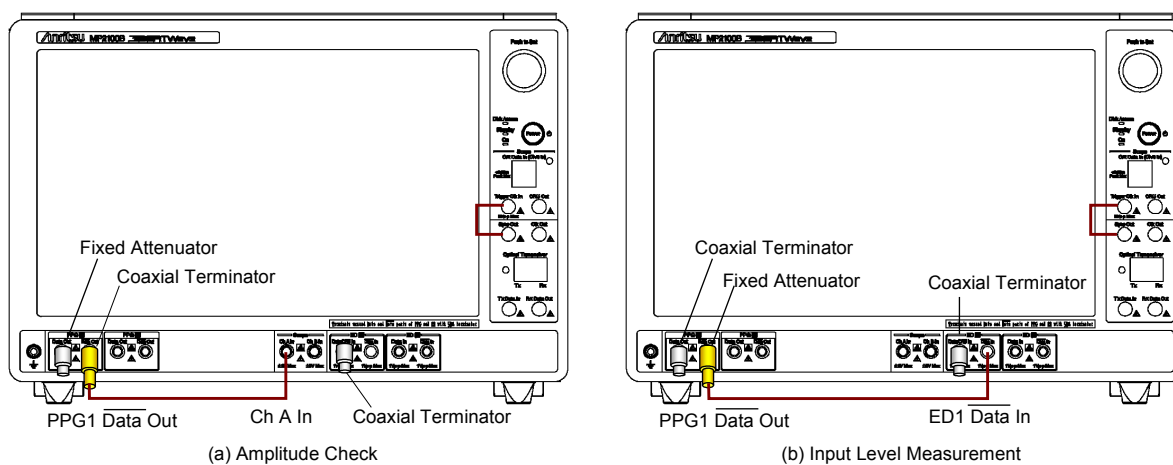

Figure 9.2.2-2 ED1 Data In Input Sensitivity Test Connection Diagram

(3) Procedure

1. Attach a 20 dB fixed attenuator to the PPG1 **Data Out** connector. (Refer to (a) in Figure 9.2.2-1.)
2. Connect coaxial terminators to the PPG1 **Data Out** and ED1 **Data In** connectors.
3. Connect the **Sync Out** and **Trigger Clk In** connectors using a coaxial cable.
4. Connect the PPG1 **Data Out** and **Ch A In** connectors using a coaxial cable.
5. Touch [PPG/ED Ch1] → [PPG].
Set the value as follows:
Amplitude: 500 mV
Bit Rate: Variable, 11320000 kbit/s (Without the Option 092)
Variable, 12500000 kbit/s (With the Option 092)
Data/XData Out: On
Reference Clock: Internal
Offset: 100 ppm
Test Pattern: PRBS 2³¹-1, Pos
6. In the Eye/Pulse Scope window, touch [CH A] to measure the amplitude.
7. Adjust the PPG1 Amplitude so that the Eye/Pulse Scope amplitude is 50±1 mV.
8. Touch [ED], and then set the value as follows:
Data Input condition: Single-Ended Data
Gating Cycle: Single
Gating Period: 90 s
Test Pattern: PRBS 2³¹-1, Pos
Threshold: 0 mV
9. Connect the PPG1 **Data Out** and ED1 **Data In** connectors using a coaxial cable. (Refer to (b) in Figure 9.2.2-1.)
10. Touch [Start] at All Measurements.
11. Record the error rate ER for the ED Result after measurement is complete.
12. Touch [PPG], and then set as follows.
Bit Rate: Variable1/64, 132813 kbit/s (Without the Option 092)
Variable, 125000 kbit/s (With the Option 092)
Offset: -100 ppm
13. Connect the PPG1 **Data Out** and **Ch A In** connectors using a coaxial cable. (Refer to (a) in Figure 9.2.2-1.)
14. In the Eye/Pulse Scope window, touch [CH A] to measure the amplitude.

15. Adjust the PPG1 Amplitude so that the Eye/Pulse Scope amplitude is 50 ± 1 mV.
16. Connect the PPG1 **Data Out** and ED1 **Data In** connectors using a coaxial cable. (Refer to (b) in Figure 9.2.2-1.)
17. Touch [Start] at All Measurements.
18. Record the error count ER for the ED Result after measurement is complete.
19. Connect coaxial terminators to the PPG1 **Data Out** and ED1 **Data In** connectors. (Refer to (a) in Figure 9.2.2-2.)
20. Attach a 20 dB fixed attenuator to the PPG1 **Data Out** connector.
21. Connect the PPG1 **Data Out** and **Ch A In** connectors using a coaxial cable.
22. Repeat steps 5 to 7.
23. Connect the PPG1 **Data Out** and ED1 **Data In** connectors using a coaxial cable. (Refer to (b) in Figure 9.2.2-2.)
24. On the [ED] tab, set Data Input Condition to [Single-Ended XData].
25. Repeat steps 10 to 12.
26. Connect the PPG1 **Data Out** and **Ch A In** connectors using a coaxial cable. (Refer to (a) in Figure 9.2.2-2.)
27. Repeat steps 14 and 15.
28. Connect the PPG1 **Data Out** and ED1 **Data In** connectors using a coaxial cable. (Refer to (b) in Figure 9.2.2-2.)
29. Repeat steps 17 and 18.

ED2 can be tested in the same way with the Option 012. The connection diagram is as follows.

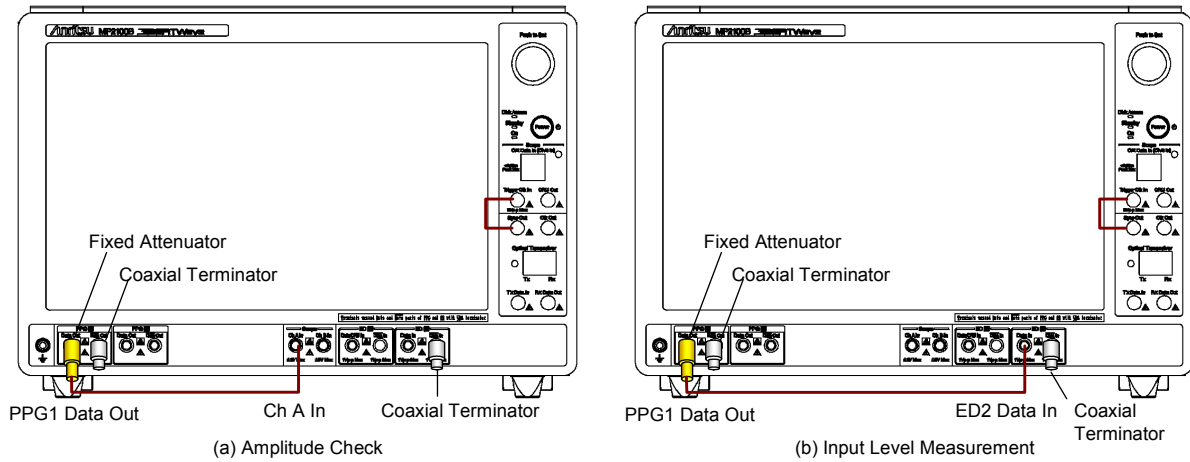

Figure 9.2.2-3 ED2 Data In Input Sensitivity Test Connection Diagram

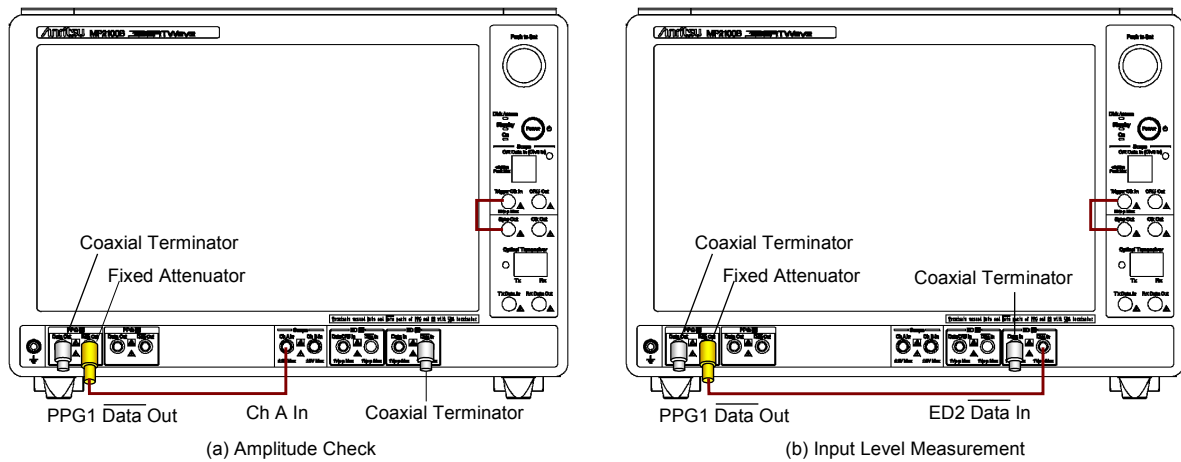

Figure 9.2.2-4 ED2 Data In Input Sensitivity Test Connection Diagram

ED3 and ED4 can be tested in the same way with the Option 014. The connection diagram for measuring the ED3 input level is as follows.

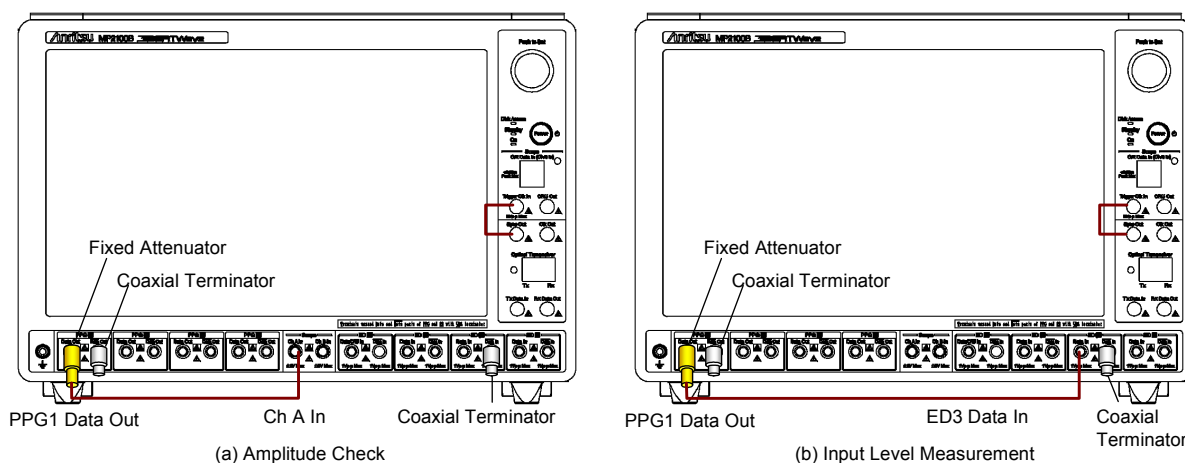

Figure 9.2.2-5 ED3 Data In Input Sensitivity Test Connection Diagram

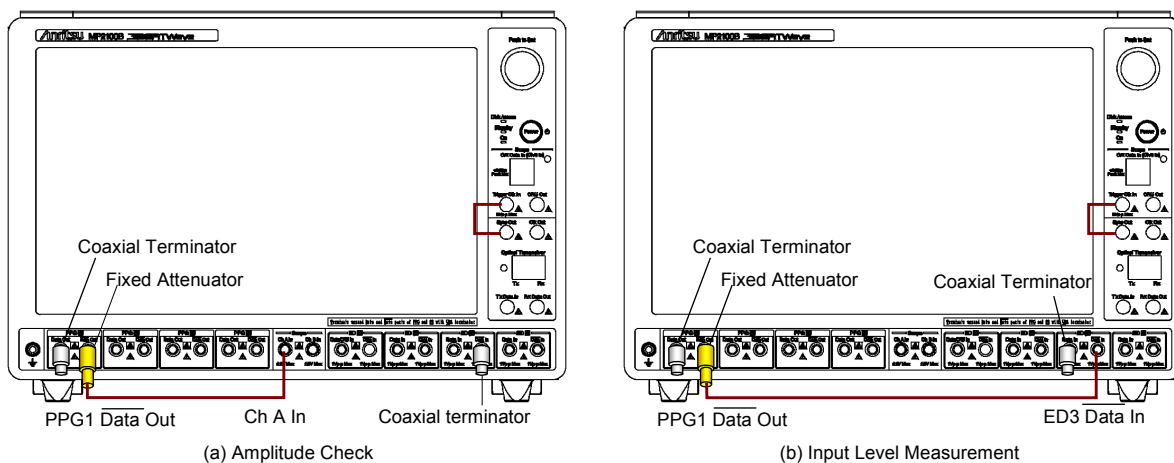

Figure 9.2.2-6 ED3 Data In Input Sensitivity Test Connection Diagram

9.2.3 Rx sensitivity

(1) Specification

20 mVp-p

BER 10^{-12} or less under the following conditions:

- Pattern: PRBS31
- Mark ratio: 50%
- Single-end
- Back-to-back connection

Without the Option 092: 11.32 Gbit/s

With the Option 092: 12.5 Gbit/s

(2) Setup

Same as Figure 9.2.2-1 and Figure 9.2.2-2.

(3) Procedure

1. Attach a 20 dB fixed attenuator to the PPG1 **Data Out** connector.
(Refer to (a) in Figure 9.2.2-1.)
2. Connect coaxial terminators to the PPG1 **Data Out** and ED1 **Data In** connectors.
3. Connect the **Sync Out** and **Trigger Clk In** connectors using a coaxial cable.
4. Connect the PPG1 **Data Out** and **Ch A In** connectors using a coaxial cable.
5. Touch [PPG], and then set the value as follows:
Amplitude: 200 mV
Bit Rate: Variable, 11320000 kbit/s (Without the Option 092)
Variable, 12500000 kbit/s (With the Option 092)
Data/XData Out: On
Error Addition: Off
Reference Clock: Internal
Offset: 0 ppm
Test Pattern: PRBS $2^{31}-1$, Pos
6. In the Eye/Pulse Scope window, touch [CH A] to measure the amplitude.
7. Adjust the PPG1 Amplitude so that the Eye/Pulse Scope amplitude is 20 ± 1 mV.
8. Touch [ED], and set the value as follows.
Data Input condition: Single-Ended Data
Gating Cycle: Single
Gating Time: 10 s
Test Pattern: PRBS $2^{31}-1$, Pos
Threshold: 0 mV

9. Connect the PPG1 **Data Out** and ED1 **Data In** connectors using a coaxial cable. (Refer to (b) in Figure 9.2.2-1.)
10. Touch [Start] at Measure.
11. Record the error rate ER for the ED Result after measurement is complete.
12. Connect coaxial terminators to the PPG1 **Data Out** and ED1 **Data In** connectors. (Refer to (a) in Figure 9.2.2-2.)
13. Attach a 20 dB fixed attenuator to the PPG1 **Data Out** connector.
14. Connect the PPG1 **Data Out** and Ch A In connectors using a coaxial cable.
15. Repeat steps 6 and 7.
16. Connect the PPG1 **Data Out** and ED1 **Data In** connectors using a coaxial cable. (Refer to (b) in Figure 9.2.2-2.)
17. Set the [ED] Data Input condition to [Single-Ended XData].
18. Touch [Start] at All Measurements.
19. Record the error rate ER for the ED Result.

ED2 can be tested in the same way with the Option 012.

The test connection diagram is the same as Figure 9.2.2-3.

ED3 and ED4 can be tested in the same way with the Option 014.

9.2.4 Maximum input level and patterns

(1) Specification

800 mVp-p

BER 10^{-12} or less under the following conditions:

- Pattern: PRBS31, PRBS23, PRBS20, PRBS15, PRBS9, PRBS7
- Mark ratio: 50%
- Single-end
- Back-to-back connection

Without the Option 092: 11.32 Gbit/s

With the Option 092: 12.5 Gbit/s

(2) Setup

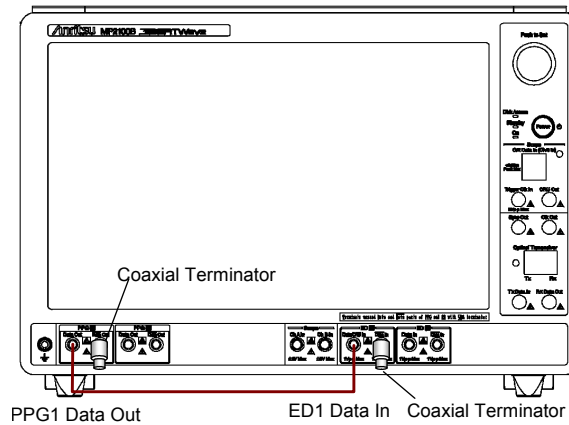

Figure 9.2.4-1 ED1 Data In Pattern Test Connection Diagram

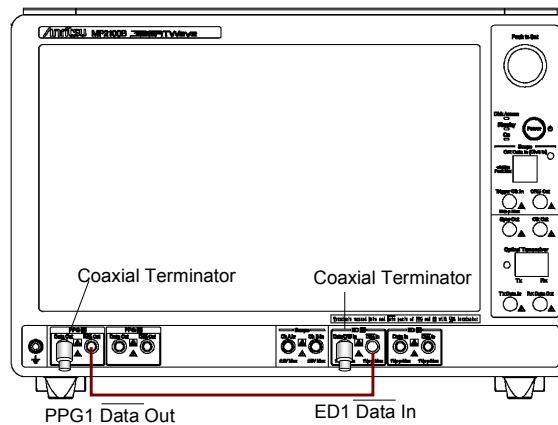

Figure 9.2.4-2 ED1 Data In Pattern Test Connection Diagram

(3) Procedure

1. Connect coaxial terminators to the PPG1 **Data Out** and ED1 **Data In** connectors. (Refer to Figure 9.2.4-1.)
2. Connect the PPG1 **Data Out** and ED1 **Data In** connectors using a coaxial cable.
3. Touch [PPG/ED Ch1] and set [PPG] as follows:
 Amplitude: 0.8 V
 Bit Rate: Variable, 11320000 kbit/s (Without the Option 092)
 Variable, 12500000 kbit/s (With the Option 092)
 Data/XData Out: On
 Error Addition: Off
 Reference Clock: Internal
 Offset: 0 ppm
 Test Pattern: PRBS 2³¹-1, Pos
4. Set [ED] as follows:
 Data Input condition: Single-Ended Data
 Gating Cycle: Single
 Gating Period: 10 s
 Test Pattern: PRBS 2³¹-1, Pos
 Threshold: 0 mV
5. Touch [Start] at Measure.
6. After measurement, confirm that the error count of the ED Result is 0.
7. Change Test Pattern for [PPG] and [ED] in succession to [PRBS 2⁷-1], [PRBS 2⁹-1], [PRBS 2¹⁵-1], and [PRBS 2²³-1], and repeat steps 5 to 7 each time.
8. Connect coaxial terminators to the PPG1 **Data Out** and ED1 **Data In** connectors. (Refer to Figure 9.2.4-2.)
9. Connect the PPG1 **Data Out** and ED1 **Data In** connectors using a coaxial cable.
10. Set [ED] at Data Input condition to [Electrical Single-Ended XData] at Data Input condition.
11. Repeat steps 3 to 7.

ED2 can be tested in the same way with the Option 012. The connection diagram is as follows.

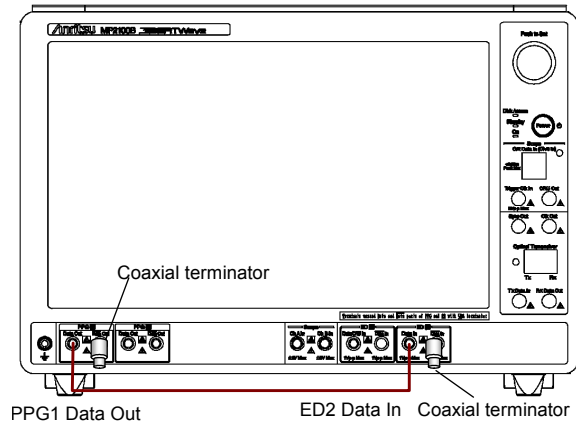

Figure 9.2.4-3 ED2 Data In Pattern Test Connection Diagram

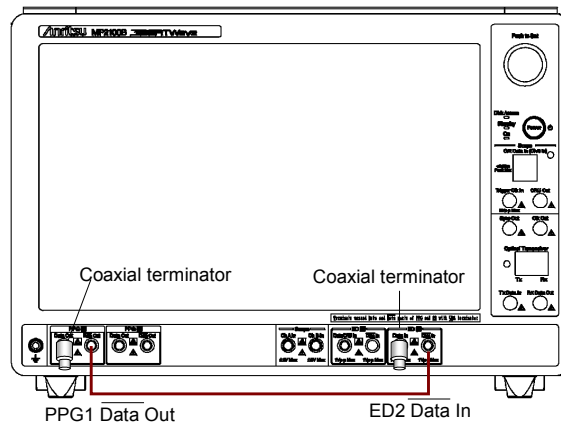

Figure 9.2.4-4 ED2 Data In Pattern Test Connection Diagram

ED3 and ED4 can be tested in the same way with the Option 014.

9.2.5 Error detection

(1) Specification

50 mVp-p

Error detection is possible for pattern PRBS31, mark ratio 50%, single end, and back to back connection.

Without the Option 092: 11.32 Gbit/s

With the Option 092: 12.5 Gbit/s

(2) Setup

Same as Figure 9.2.2-1 and Figure 9.2.2-2.

(3) Procedure

1. Attach a 20 dB fixed attenuator to the PPG1 **Data Out** connector. (Refer to (a) in Figure 9.2.2-1.)
2. Connect coaxial terminators to the PPG1 **Data Out** and ED1 **Data In** connectors.
3. Connect the **Sync Out** and **Trigger Clk In** connectors using a coaxial cable.
4. Connect the PPG1 **Data Out** and **Ch A In** connectors using a coaxial cable.
5. Touch [PPG/ED Ch1], and then touch [PPG].
Set the value as follows:
Amplitude: 500 mV
Bit Rate: Variable, 11320000 kbit/s (Without the Option 092)
Variable, 12500000 kbit/s (With the Option 092)
Data/XData Out: On
Reference Clock: Internal
Offset: 100 ppm
Test Pattern: PRBS 2³¹-1, Pos
6. In the Eye/Pulse Scope window, touch [CH A] to measure the amplitude.
7. Adjust the PPG1 Amplitude so that the Eye/Pulse Scope amplitude is 50 mV ±1 mV.
8. Touch [ED], and set as follows.
Data Input condition: Single-Ended Data
Gating Cycle: Single
Gating Period: 10 s
Test Pattern: PRBS 2³¹-1, Pos
Threshold: 0 mV
9. Connect the PPG1 **Data Out** and ED1 **Data In** connectors using a coaxial cable. (Refer to (b) in Figure 9.2.2-1.)
10. Touch [Start] at All Measurements.

11. Touch [PPG] at [Insert Error] once.
12. After measurement, confirm that the bit error rate of the ED Result is 1E-11 and the error count is 1.
13. Connect coaxial terminators to the PPG1 **Data Out** and ED1 **Data In** connectors. (Refer to (a) in Figure 9.2.2-2.)
14. Attach a 20 dB fixed attenuator to the PPG1 **Data Out** connector.
15. Connect the PPG1 **Data Out** and Ch A In connectors using a coaxial cable.
16. Repeat steps 5 to 7.
17. Connect the PPG1 **Data Out** and ED1 **Data In** connectors using a coaxial cable. (Refer to (b) in Figure 9.2.2-2.)
18. On the [ED] tab, set Data Input Condition to [Single-Ended XData].
19. Repeat steps 10 to 12.

ED2 can be tested in the same way with the Option 012.

The test connection diagram is the same as Figure 9.2.2-3.

ED3 and ED4 can be tested in the same way with the Option 014.

9.3 Performance Test for Sampling Oscilloscope

This section describes the performance test item for the sampling oscilloscope.

- Amplitude accuracy

9.3.1 Required equipment

The following table shows the equipment required for the performance test.

Before starting performance tests, warm up the BERTWave and measuring instruments for at least 1 hour.

Table 9.3.1-1 Equipment for Performance Test

Product Name	Required Performance	Recommended Equipment
Pulse Pattern Generator	Clock frequency: 10 GHz Amplitude: 0.5 V _{p-p}	MP1800A, MU181000A MU181020A (Anritsu)
DC Power Source	Power voltage: ±2.5 V Power current: ±50 mA Setting accuracy: 1% or less With current limiting function	2400 (Keithley Instruments)

9.3.2 Amplitude accuracy

(1) Specification

(-2%-offset amplitude accuracy) to (+2%+offset amplitude accuracy)

The offset amplitude accuracy after calibration is as shown in the following figure.

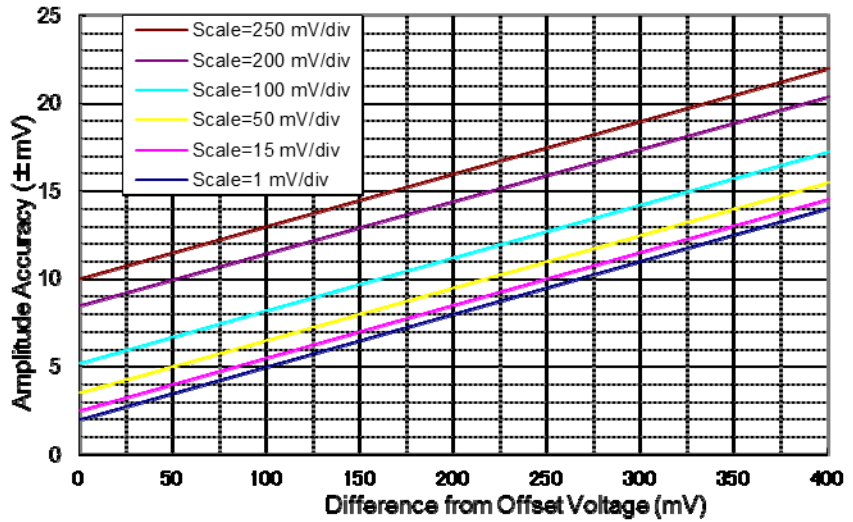

Figure 9.3.2-1 Offset Amplitude Accuracy

(2) Setup

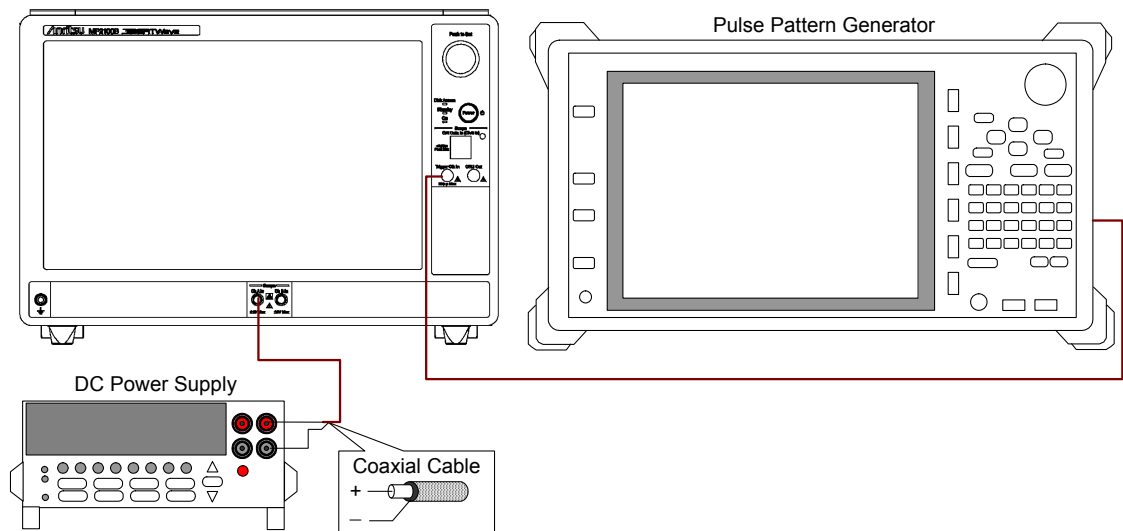

Figure 9.3.2-2 Amplitude Accuracy Test Connection Diagram

(3) Procedure

1. Connect the Trigger Input and the clock output connector of the PPG using a coaxial cable.
2. Set the clock output of the PPG as follows:
 - Amplitude: 0.5 V_{p-p}
 - Frequency: 10 GHz
3. Touch [Setup], and set as follows:
 - Sampling Mode: EYE
 - Accumulation Type: None
 - Clock Recovery: Off
 - Divide Ratio: 1
4. Touch [Time], and set as follows:
 - Unit: UI
 - Bits On Screen: 2
 - Offset: 0
 - Data Clock Rate – Tracking: Off
 - Clock Rate: 10 000 000 kHz
 - Divide Ratio: 1
5. Touch [Amplitude], and set as follows:
 - Channel Math: Off
 - Channel A/B Tracking: Off
 - Scale – A: 50 mV/div
 - Offset – A: 0 mV
 - Attenuation – A: 0 dB
6. Touch [Measure], and set as follows:
 - Active Channel Selection: Channel A
 - Measure Item: Histogram
 - Histogram – Axis: Amplitude
 - X1: 0
 - X2: 2
 - Y1: –250 mV
 - Y2: 250 mV
7. Set the Current Limit of DC Power Source to 20 mA.
8. Set the DC voltage to 0 V.
9. Connect the DC Power Source to Ch A In.
Connect the center conductor of the coaxial cable to plus and the shield to minus.
10. Touch [CH A] to set to On.
11. Touch [Sampling] to set to Run.
12. Record the average value (Mean) of the histogram measurement result.

13. Set the DC voltage to 200 mV.
14. Record the average value of the histogram measurement result.
15. Set the DC voltage to -200 mV.
16. Record the average value of the histogram measurement result.

With the Option 021, test the amplitude accuracy for Ch B after measuring the amplitude accuracy for Ch A.

1. Touch [Amplitude], and set as follows:
Channel Math: Off
Channel A/B Tracking: Off
Scale – B: 50 mV/div
Offset – B: 0 mV
Attenuation – B: 0 dB
2. Touch [Measure], and set as follows:
Active Channel Selection: Channel B
3. Set the DC voltage to 0 V.
4. Connect the DC Power Source to Ch B In.
Connect the center conductor of the coaxial cable to plus and the shield to minus.
5. Touch [CH B] to set to On.
6. Touch [Sampling] to set to Run.
7. Record the average voltage (Mean) of the histogram measurement result.
8. Set the DC voltage to 200 mV.
9. Record the average value of the histogram measurement result.
10. Set the DC voltage to -200 mV.
11. Record the average voltage of the histogram measurement result.

9.4 Performance Test for Optical Interface (O/E Converter)

This section describes the performance test item for the O/E converter.

- Optical power meter

9.4.1 Required equipment

The following table list the equipment required for the performance test.

Before starting performance tests, warm up the BERTWave and the measuring instruments for at least 1 hour.

Table 9.4.1-1 Equipment for O/E Converter Performance Test

Product Name	Required Performance	Recommended Equipment
Light source	Wavelength: 850, 1310, 1550 nm Output level range: +3 dBm min. Level accuracy: ± 0.05 dB	
Optical power meter	Wavelength range: 750 to 1700 nm Level range: -40 to +10 dBm (100 nW to 10 mW) Level accuracy: 5% Linearity: ± 0.05 dB min.	
Variable optical attenuator	For single-mode fiber Wavelength: 1200 to 1600 nm Insertion loss: 3 dB max. Attenuation: 0 to 30 dB Resolution: 0.1 dB max. For multimode fiber Attenuation: 800 to 900 nm Insertion loss: 3 dB max. Attenuation: 0 to 30 dB Resolution: 0.1 dB max.	8163B+81570A (Keysight Technologies) 8163B+81578A (Keysight Technologies)
Pulse Pattern Generator or Signal Generator	Clock frequency: 100 MHz Amplitude: 0.5 Vp-p	MG3740A (Anritsu)

9.4.2 Optical Power Meter

(1) Specification

Accuracy: ± 0.35 dB if the input level is -12 dBm or greater

(2) Setup

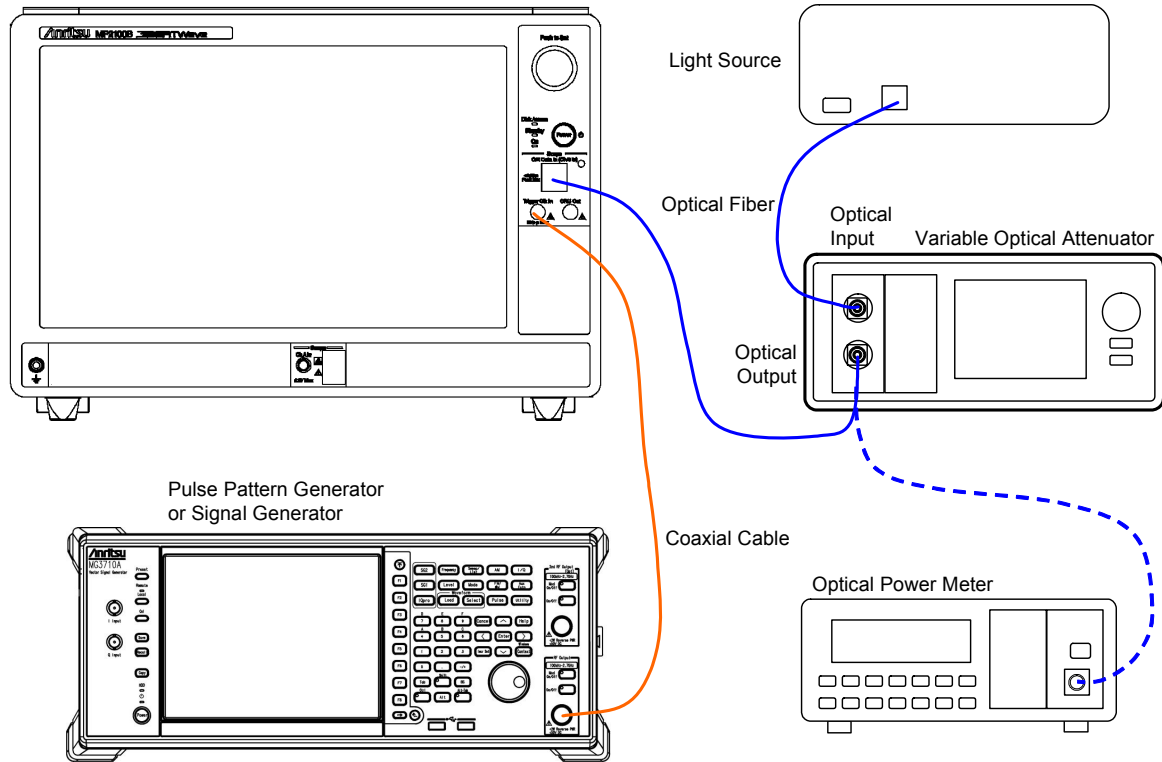

Figure 9.4.2-1 Optical Power Meter Test Connection Diagram (Option 023)

(3) Procedure

1. Connect the signal generator output and Trigger Clk In using a coaxial cable.
2. Set the signal generator as follows:
Frequency: 100 MHz
Amplitude: 0.5 V_{p-p} (at sine-wave -2.0 dBm)
3. Connect the output connector of the light source and the input connector of the variable optical attenuator for multimode fiber, using a multimode optical fiber.
4. Connect the output connector of the variable optical attenuator for multimode fiber and the optical power meter, using a multimode optical fiber.
5. Set the light source wavelength to 850 nm.
6. Set the optical power meter wavelength to 850 nm.
7. Set the light source output to On.

9.4 Performance Test for Optical Interface (O/E Converter)

8. Adjust the variable optical attenuation to set the optical power meter display to around -1 dBm (0.8 mW).
9. Record the optical power meter display P (dBm).
10. Disconnect the optical fiber from the optical power meter and connect it to the O/E Data In connector.
11. Touch [O/E].
12. Touch the [Wavelength] button and set to 850.
13. Touch [EYE/Pulse Scope], and then set the value as follows:
CH_A: Off
CH_B: On
14. Set [Sampling] to Run.
15. Touch [Measure] and [Amplitude/Time].
16. Add [Average Power (dBm)] in the Item Selection.
17. Record the displayed Average Power (dBm).
18. Turn off the light source output.
19. Connect the output connector of the light source and the input connector of the variable optical attenuator for single-mode fiber, using a single-mode optical fiber.
20. Connect the output connector of the variable optical attenuator for single-mode fiber and the optical power meter, using a single-mode optical fiber.
21. Set the light source wavelength to 1310 nm.
22. Set the optical power meter wavelength to 1310 nm.
23. Repeat steps 7 to 11.
24. Touch the [Wavelength] button and set to 1310.
25. Repeat steps 14 to 18.
26. Set the light source wavelength to 1550 nm.
27. Set the optical power meter wavelength to 1550 nm.
28. Repeat steps 7 to 11.
29. Touch the [Wavelength] button and set to 1550.
30. Repeat steps 14 to 18.

Chapter 10 Maintenance

This chapter describes maintenance, storage and disposal procedures.

10.1	Daily Maintenance	10-2
10.2	Replacement of Optical Connector.....	10-3
10.3	Optical Connector/Optical Adapter Cleaning.....	10-5
10.4	Displaying Software Version.....	10-8
10.5	Updating Software	10-10
10.6	Touch Panel Position Calibration.....	10-11
10.7	Calibration.....	10-13
10.8	Cautions on Storage	10-14
10.9	Transporting and Disposal.....	10-15

10.1 Daily Maintenance

Before daily maintenance of the BERTWave, be sure to turn the power off and unplug it from the AC outlet.

Panel surface dirt

When surface dirt is noticeable, after the BERTWave has been used in a dusty environment, or when the BERTWave has not been used for an extended period of time, wipe its surface with a cloth moistened in detergent and wrung enough.

Screen surface dirt

During maintenance work, avoid using organic solvent, such as benzene and thinner; otherwise such chemicals may damage the surface of screen. Lightly wipe this surface with a dry, soft waste cloth or soft cloth slightly moistened in ethanol.

Loose screws

Use a Phillips screwdriver to tighten screws.

10.2 Replacement of Optical Connector

The standard optical connector is the FC type. The optical connector of the plug-in unit and pull-out type optical sensor can be removed and replaced with another connector (sold separately), and its interior can be cleaned. For information, Figure 10.2-1 shows the connector type.

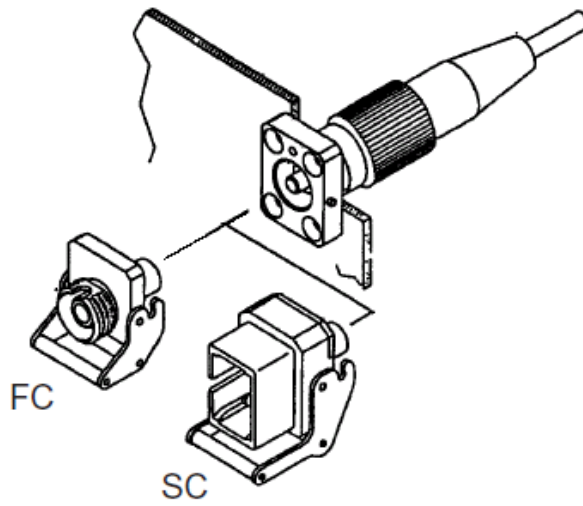

Figure 10.2-1 Connector Type

WARNING

Do not look into the connection surface of the optical fiber cable of the light source optical connector or the end face of the optical fiber cable connected to the light source as invisible laser light output may cause visual deficit and other problems.

CAUTION

Before replacing the optical fiber cable, be sure not to damage the connector and connection surface with connector.

To remove the optical connector:

1. Open the cover.
2. Pull up the connector lever toward you.
3. Check that the latch has been released, and then, gently pull the connector out straight toward you.

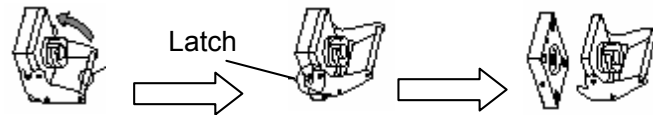

Figure 10.2-2 How to Remove the Optical Connector

10.3 Optical Connector/Optical Adapter Cleaning

Cleaning the Ferrule End Surface

Use an approved adapter cleaner to clean the ferrule end surface in the optical connector. The ferrule in the optical connectors needs periodic cleaning. Although the following procedures use the FC connector and adapter as an example, use the same methods when cleaning other connector and adapter types.

1. Remove the currently connected adapter by raising the adapter lever (you will hear a “click” when the latch disengages) and then gently pull the adapter straight towards you.

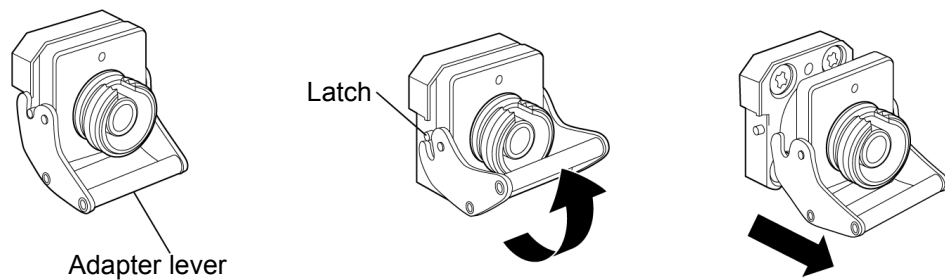

2. Moisten an adapter cleaner with isopropyl alcohol and then use it to clean the end surface and sides of the ferrule.

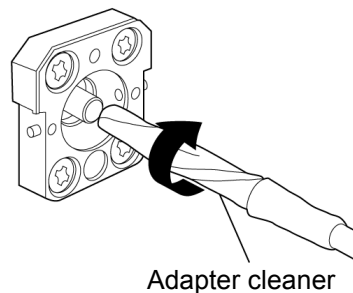

3. Press the tip of a new (dry) adapter cleaner into the ferrule end surface and then wipe in one direction 2 or 3 times to dry the surface.

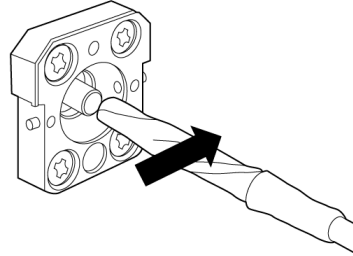

4. Clean the adapter interior with adapter cleaner. (Refer to “Cleaning the optical adapter” below.)
5. Attach the adapter in the reverse order. Be careful not to scratch the ferrule end surface.

Cleaning the Optical Adapter

Use an approved adapter cleaner to clean the optical fiber cable optical adapter. Although the following procedures use the FC connector and adapter as an example, use the same methods when cleaning other connector and adapter types.

Insert adapter cleaner into the split sleeve of the optical adapter. Rotate the adapter cleaner in one direction while moving it back and forth.

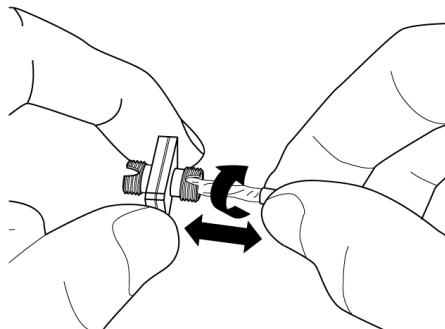

Note:

Check the ferrule diameter and use a cleaner only for the 1.25 mm or 2.5 mm adapter.

Cleaning the Optical Fiber Cable Ferrule End Surface

Use an approved ferrule cleaner to clean the optical fiber cable ferrule end surface. Although the following procedures use the FC connector and adapter as an example, use the same methods when cleaning other connector and adapter types.

1. Pull the ferrule cleaner lever to expose the cleaning surface.

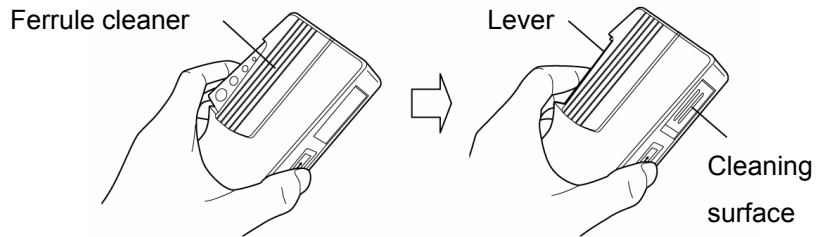

2. Hold the lever in the opened position, press the optical connector ferrule end into the cleaning surface, and then rub in one direction as shown in the following figure.

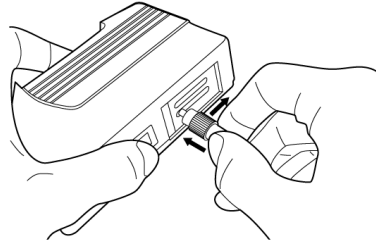

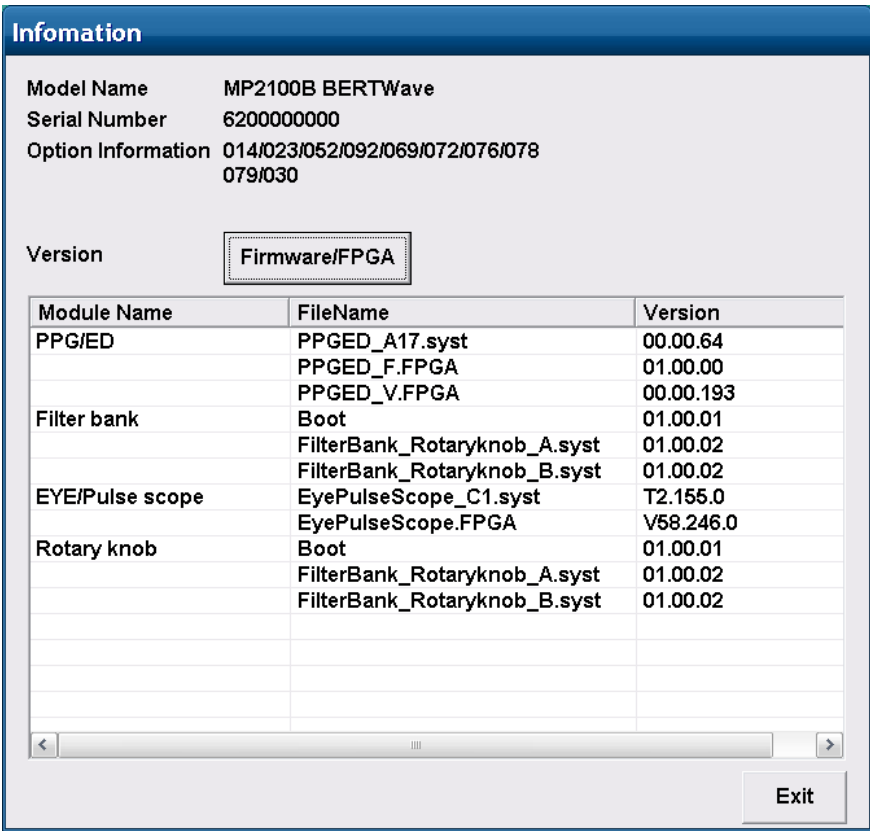

- 4. Touch [Exit], and then the software version display screen is closed.

10.5 Updating Software

To update the software, install the new software in the BERTWave. For how to install the software, refer to the document attached to the software.

Start the BERTWave after installing the software, and then the version mismatch warning is displayed.

At this time, update the software referring the following procedures.

1. Touch [Setup Utility] at the selector screen, and then the Setup Utility screen opens.
2. Touch [Update], and then the Update screen is displayed.

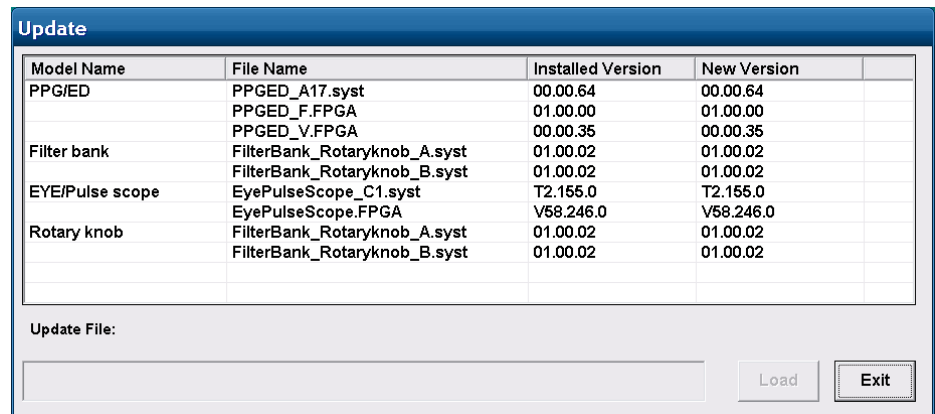

3. Touch [Load], and then the software upgrading is started.
If the software to update does not exist, the [Load] button is invalid.
4. When the software update procedure is finished, the Reboot screen is displayed.



5. After closing the Reboot screen, touch [Exit].

10.6 Touch Panel Position Calibration

Touch panel position may be misaligned depending on the changes of ambient environment (temperature/humidity). If the touch panel position is misaligned, calibrate the position using the following procedures. When calibrating the detecting position, use the sharp-nose stick but do not scratch the panel surface.

1. The Windows Control Panel is displayed.
2. Touch [Touch Panel] twice.
The property window of the touch panel is displayed.

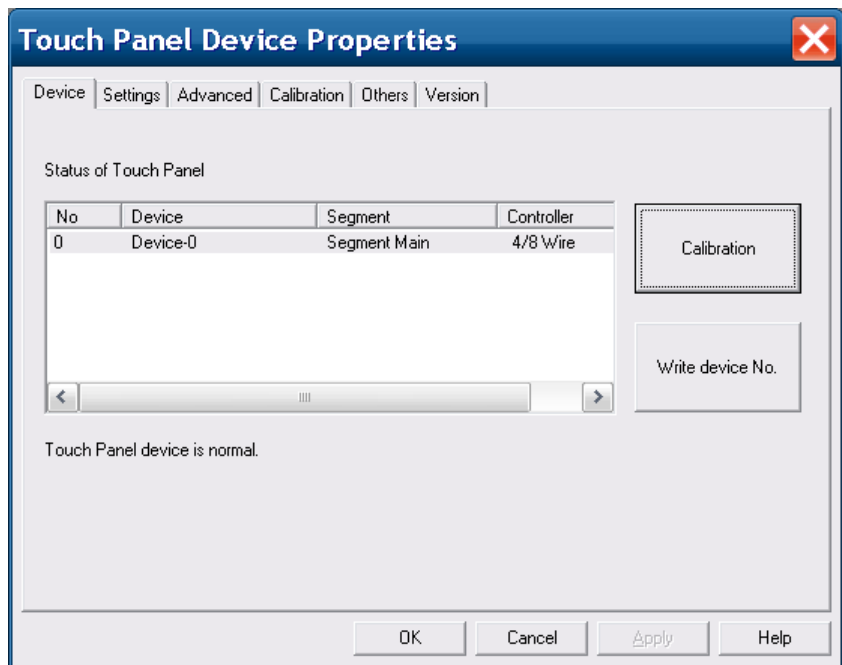

3. Touch [Calibration].
The screen to input the position is displayed.

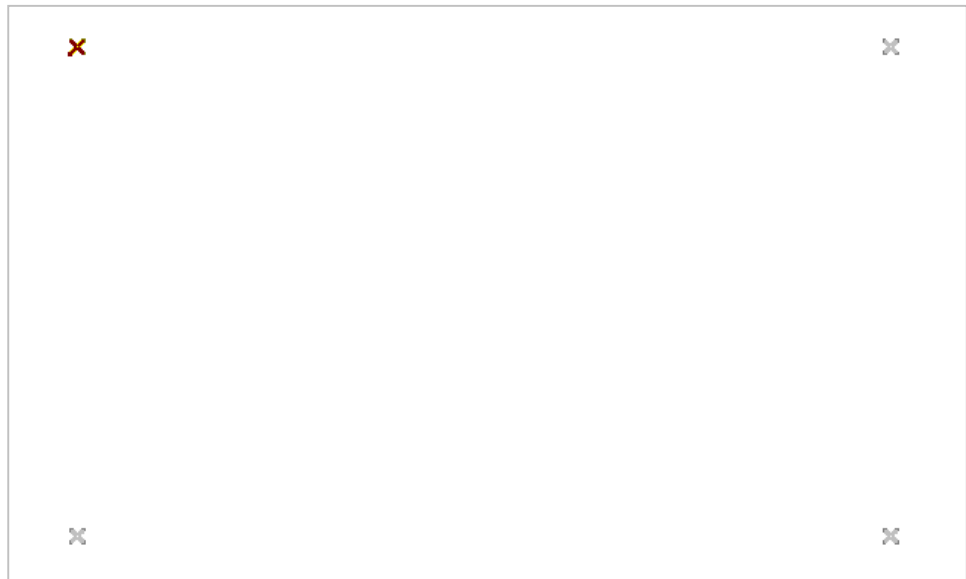

4. Touch the center of the brown cross using the sharp-noise stick. The next cross to be touch is displayed in brown.
5. Touch the four crosses, and then the property window of the touch panel is displayed.
6. Touch the [OK] button.

10.7 Calibration

Regular maintenance such as periodic inspections and calibration is essential for the BERTWave for long-term stable performance. Regular inspection and calibration are recommended for using the BERTWave in its prime condition at all times. The recommended calibration cycle after delivery of the BERTWave is twelve months.

If you require support after delivery, contact an Anritsu Service and Sales office. Contact information can be found on the last page of the printed version of this manual, and is available in a separate file on the CD version.

We may not provide calibration or repair if any of the following cases apply.

- Five or more years have elapsed after production and parts for the instrument are difficult to obtain, or it is determined that reliability cannot be maintained after calibration/repair due to significant wear.
- Circuit changes, repair, or modifications are done without our approval.
- It is determined that the repair cost would be higher than the price of a new item.

10.8 Storage

Wipe off dust, fingerprint marks, stains, spots, etc. from the surface of the BERTWave before storing it.

Fit the attached coaxial connector cover to the coaxial connector on the front panel. Also, put the cap on the optical connector.

Put the power cord, CD-ROM and other accessories in the accessory box and store it with the main frame.

Avoid storing the BERTWave in these places:

- In direct sunlight for extended periods
- Outdoors
- In excessively dusty locations
- In liquids, such as water, oil, organic solvents, and medical fluids, or places where these liquids may adhere
- In salty air or where chemically active gases (sulfur dioxide, hydrogen sulfide, chlorine, ammonia, nitrogen oxide, or hydrogen chloride etc.) are present
- Where toppling over may occur
- In the presence of lubricating oil mists
- In places at an altitude of more than 2,000 m
- In the presence of frequent vibration and mechanical shock, such as in cars, ships, and airplanes
- Places with temperatures and relative humidity in the following ranges:

Temperature:	lower than -20°C or higher than 60°C
Humidity:	90% or more

Recommended storage conditions

It is recommended that the BERTWave be stored in a place that meets the ambient conditions suggested above, plus the following conditions, if it is not to be used for a long period of time:

- Temperature: 5 to 45°C
- Humidity: 40 to 80%
- Little temperature and humidity fluctuations within one day

10.9 Transporting and Disposal

The following describes precautions for transporting and disposing of the BERTWave.

Repackaging

Repack the BERTWave in the packing material (box) in which it was delivered. If the packing material has been thrown away or damaged, repack the BERTWave in the following manner:

1. Prepare a corrugated cardboard, wooden, or aluminum box large enough to pack cushioning material in around the BERTWave.
2. Wrap the BERTWave in plastic or a similar material to avoid water droplets and dust.
3. Put the BERTWave in the box.
4. Pack the BERTWave in cushioning material so it does not move in the box.
5. Secure the outside of the box with packing cord, adhesive tape, bands, or other similar materials.

Transporting

Avoiding vibrations as much as possible and meet the recommended storage conditions during transport.

Disposal

Follow the instructions of your local waste disposal office when disposing of the BERTWave.

Before disposing of the BERTWave, dismantle or physically destroy any memory media it contains to ensure that any data saved in memory cannot be recovered by third parties.

Appendix A Specifications

Appendix A describes the specifications for the BERTWave.
For the configuration of the BERTWave, refer to Section 1.2
“Configuration”.

A.1	MP2100B BERTWave.....	A-2
A.1.1	Pulse Pattern Generator.....	A-2
A.1.2	Error Detector	A-8
A.1.3	Sampling Oscilloscope	A-12
A.1.4	General Performance.....	A-23
A.2	Optical Transceiver Module.....	A-24

A.1 MP2100B BERTWave

A.1.1 Pulse Pattern Generator

Table A.1.1-1 Reference Clock

Item	Specifications
Internal reference clock	Frequency: 10 MHz Accuracy: ± 10 ppm*1,*2
External 10 MHz input	Frequency: 10 MHz ± 100 ppm Connector: BNC jack Termination: 50 Ω , AC coupling Amplitude: 0.7 to 2 Vp-p Waveform: Square or sine wave
External reference clock input	Frequency: 1/16 of operating bit rate 531.25 to 707.5 MHz ± 100 ppm 390.625 to 781.25 MHz ± 100 ppm*3 Connector: SMA jack Termination: 50 Ω , AC coupling Amplitude: 0.2 to 1.6 Vp-p Waveform: Square or sine wave

*1: 1 hour after power-on

*2: Option 011: Common to ED1.

Option 012: Common to PPG1, PPG2, ED1 and ED2.

Option 014: Common to PPG1 to PPG4 and ED1 to ED4.

*3: Only Option 092

Table A.1.1-2 Bit Rate

Item	Specifications		
Bit Rate (kbit/s)	Standard Name	Without Option 092	With Option 092
	Variable	8500000 to 11320000	125000 to 12500000
	Variable 1/2*1	4250000 to 5660000	—
	Variable 1/4*1	2125000 to 2830000	—
	Variable 1/8*1	1062500 to 1415000	—
	Variable 1/16*1	531250 to 707500	—
	Variable 1/32*1	265625 to 353750	—
	Variable 1/64*1	132813 to 176875	—
	1GFC	1062500	1062500
	2GFC	2125000	2125000
	4GFC	4250000	4250000
	8GFC	8500000	8500000
	10GFC	10518750	10518750
	10GFC FEC	11316800	11316800
	1GbE	1250000	1250000
	2GbE	2500000	2500000
	10GbE WAN/PHY	9953280	9953280
	10GbE LAN/PHY	10312500	10312500
	10GBASE-LRM	10312500	10312500
	10GSFP+Cu	10312500	10312500
	10GbE FEC OTU-1e	11049107	11049107
	10GbE FEC OTU-2e	11095728	11095728
	40GBASE-CR4	10312500	10312500
	40GBASE-SR4 (XLPP)	10312500	10312500
	40GBASE-LR4	10312500	10312500
	Infiniband	2500000	2500000
	Infiniband × 2	5000000	5000000
Infiniband × 4	10000000	10000000	

Table A.1.1-2 Bit Rate (Cont'd)

Item	Specifications		
Bit Rate (kbit/s) (Cont'd)	Standard Name	Without Option 092	With Option 092
	OC-3/STM-1	155520	155520
	OC-12/STM-4	622080	622080
	OC-24	1244160	1244160
	OC-48/STM-16	2488320	2488320
	OTU-1	2666057	2666057
	OC-192/STM-64	9953280	9953280
	OC-192/STM-64	10664228	10664228
	FEC G.975		
	OTU-2	10709225	10709225
	CPRI	614400	614400
	CPRI × 2	1228800	1228800
	CPRI × 4	2457600	2457600
	CPRI × 5*2	–	3072000
	CPRI × 10*2	–	6144000
	OBSAI RP3*2	–	768000
	OBSAI RP3 × 2*2	–	1536000
OBSAI RP3 × 4*2	–	3072000	
OBSAI RP3 × 8*2	–	6144000	
Bit rate offset	±100 ppm*3		

*1: Only without Option 092

*2: Only Option 092

*3: When using internal and external clocks of 10 MHz

Table A.1.1-3 Data Output

Item	Specifications
Number of Channels *1	Option 011: 1 Option 012: 2 Option 014: 4
Amplitude	0.1 to 0.8 Vp-p, 10 mV resolution*2 Accuracy: ± 20 mV $\pm 20\%$ for settings Relative display*3: available
Termination	AC coupling, 50 Ω
Data Crossing	50% Accuracy: $\pm 10\%$ *4
Rise/Fall time	Typ.: 24 ps*4,*5 Max.: 28 ps*4,*5
Jitter	Jitter (RMS) Typ.: 1 ps*6,*7 Max.: 2 ps*7,*8 Intrinsic RJ (RMS) Typ.: 600 fs*6,*7,*9 Max.: 1 ps *6,*7,*9
Skew	± 15 ps max.*4
Connector	SMA jack

*1: Each channel has both of the **Data Output** and **Data Output** connectors, which are for single-ended or differential output.

*2: When without Option 092: At 10.3125 Gbit/s and 11.32 Gbit/s
When with Option 092: At 10.3125 Gbit/s and 12.5 Gbit/s

*3: Value obtained by multiplying “amplitude” by “external attenuation factor”

*4: When without Option 092:
Bit rate: 11.32 Gbit/s, Amplitude: 0.8 Vp-p
When with Option 092:
Bit rate: 12.5 Gbit/s, Amplitude: 0.8 Vp-p

*5: Time changing between 20 to 80% amplitude

*6: When using an oscilloscope having residual jitter of <200 fs (RMS) and a clock with SSB phase noise of -102 dBc/Hz or less at an offset of 100 kHz, in the temperature range of 20 to 30°C

*7: Amplitude: 0.4 Vp-p, Bit rate: 10.3125 Gbit/s

*8: When using an oscilloscope having residual jitter of <1 ps (RMS)

*9: Pattern setting: Alternate ones and zeroes

Table A.1.1-4 Sync Output

Item	Specifications											
Frequency	Sync Signal Source	PPG1, PPG2						PPG3, PPG4	ED1 to ED4			
	Division Ratio	1/1	1/2	1/4	1/8	1/16	1/64	Pattern Sync.	Pattern Sync.	1/4	1/8	1/16
	Bit Rate											
	Division Ratio											
	Rate 1/64	✓						✓	✓			
	Rate 1/32	✓						✓	✓			
	Rate 1/16	✓						✓	✓			
	Rate 1/8	✓						✓	✓			
	Rate 1/4	✓	✓			✓		✓	✓			
	Rate 1/2		✓	✓		✓		✓	✓	✓		✓
Rate 1/1			✓	✓	✓	✓	✓	✓		✓	✓	
Connector	SMA jack*1											
Termination	50 Ω											
Low level (V _{OL})	-0.5 to -0.3 V											
High level (V _{OH})	-0.1 to 0 V											
Amplitude	0.4 V _{p-p} *2											

*1: For outputting a signal that is synchronized with one of PPG1 to PPG4 or ED1 to ED4.

*2: Nominal value

Table A.1.1-5 Function

Item	Specifications
External attenuator factor	0 to 30 dB, 1 dB resolution
Error addition	Addition mode: Single, Repeat Error rate: 1E-n (n: 2 to 12)
Test pattern	Pseudorandom (PRBS) pattern: Pattern length: 2 ⁷ -1, 2 ⁹ -1, 2 ¹⁵ -1, 2 ²³ -1, 2 ³¹ -1 Logic invertible Programmable Pattern: Pattern length: 2 to 1305600 bit, editable by text editor and sample file available

Table A.1.1-6 Slot for Optical Transceiver

Item	Specifications
SFP+Slot (MP2100B-051)	Transmission data input Connector: SMA jack Terminator voltage: 0 V Impedance: 50 Ω*1 Input amplitude: 0.6 to 0.8 Vp-p (When using G0238A) 0.25 to 0.35 Vp-p (When using G0239A) Waveform: NRZ Received data output Connector: SMA jack Terminator voltage: 0 V Impedance: 50 Ω*1 Output amplitude: 0.10 to 1.0 Vp-p*2 Waveform: NRZ Functions Status indicator for module availability Module information display: Wavelength*3, LOS, optical output

*1: Nominal value

*2: When the input optical power is in the range of the recommended SFP+ module input optical power

*3: When G0238A or G0239A is installed

A.1.2 Error Detector

Table A.1.2-1 Data Input

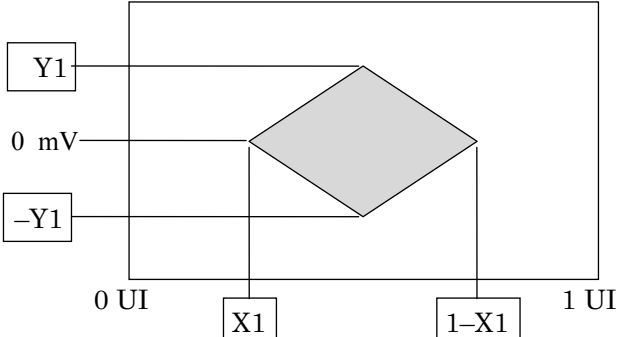
Item	Specifications												
Bit Rate	Refer to “bit rate” in Table A.1.1-2.												
Number of Channel *1	Option 011: 1 Option 012: 2 Option 014: 4												
Data format	NRZ, mark ratio 1/2												
Amplitude	0.05 to 0.8 Vp·p*2, *3												
Coupling method	DC coupling, termination voltage 0 V												
Threshold	-85 mV to 85 mV*4, 1 mV resolution												
Sensitivity	Typ. 10 mVp·p*3, *5 Max. 20 mVp·p*3, *5												
Stressed Eye	BER 10 ⁻¹² (Guaranteed for the trace specified by the stressed mask) *6, *7												
Stressed Mask	 <table border="1" data-bbox="481 1276 1169 1433"> <thead> <tr> <th>Bit Rate</th> <th>X1 (UI)</th> <th>Y1 (mV)</th> </tr> </thead> <tbody> <tr> <td>10.315 Gbit/s</td> <td>0.325</td> <td>25</td> </tr> <tr> <td>4.25 Gbit/s</td> <td>0.325</td> <td>25</td> </tr> <tr> <td>2.125 Gbit/s</td> <td>0.325</td> <td>25</td> </tr> </tbody> </table>	Bit Rate	X1 (UI)	Y1 (mV)	10.315 Gbit/s	0.325	25	4.25 Gbit/s	0.325	25	2.125 Gbit/s	0.325	25
Bit Rate	X1 (UI)	Y1 (mV)											
10.315 Gbit/s	0.325	25											
4.25 Gbit/s	0.325	25											
2.125 Gbit/s	0.325	25											
Total Jitter TJ	0.65 UI*7												
Deterministic Jitter DJ(d-d)	0.45 UI*7												
SJ(p-p)	0.22 UI*7												
Connector	SMA jack												
External attenuator factor	0 to 30 dB*8, 1 dB resolution												

*1: Each channel has both of the **Data Input** and **Data Input** connectors, which are for single-ended or differential input.

*2: Without Option 092: 132.813 Mbit/s to 11.32 Gbit/s
With Option 092: 125 Mbit/s to 12.5 Gbit/s

*3: Pattern: PRBS31, Mark ratio: 1/2, Single-ended, Back-to-back connection

- *4: Terminator: Single-ended, External attenuation factor: 0 dB
- *5: Without Option 092: 11.32 Gbit/s, 20 to 30°C
With Option 092: 12.5 Gbit/s, 20 to 30°C
- *6: Guaranteed by design.
- *7: At 10.315 Gbit/s, 4.25 Gbit/s, and 2.125 Gbit/s
- *8: The thresholds corrected by the external attenuation factor are displayed. The formulas are shown below:
Upper threshold = $85 \times 10^{(\text{factor}/20)}$
Lower threshold = $-85 \times 10^{(\text{factor}/20)}$
Resolution = $1.0 \times 10^{(\text{factor}/20)}$

Table A.1.2-2 Clock Recovery

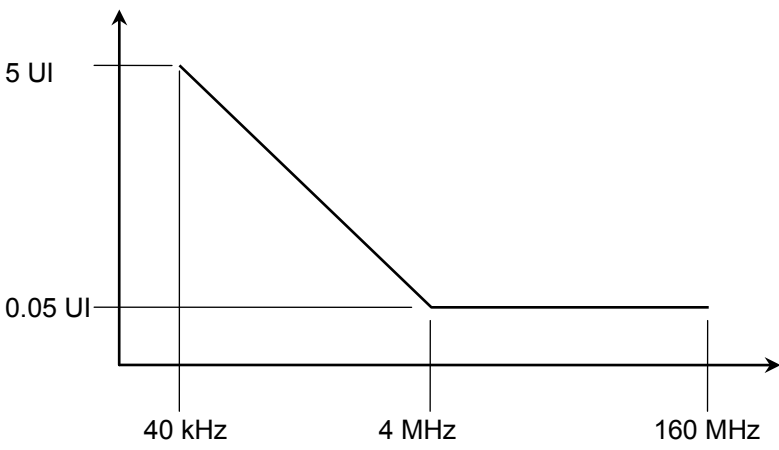
Item	Specifications						
Consecutive identical digit immunity	72 bits or more* ¹						
Lock range	±100 ppm* ²						
Jitter tolerance* ³	<table border="0" style="width: 100%; border-collapse: collapse;"> <tr> <td style="text-align: center; width: 50%;">Modulation frequency</td> <td style="text-align: center; width: 50%;">Jitter tolerance</td> </tr> <tr> <td style="text-align: center;">40 kHz to 4 MHz</td> <td style="text-align: center;">5 to 0.05UI</td> </tr> <tr> <td style="text-align: center;">4 to 160 MHz</td> <td style="text-align: center;">0.05UI</td> </tr> </table> 	Modulation frequency	Jitter tolerance	40 kHz to 4 MHz	5 to 0.05UI	4 to 160 MHz	0.05UI
Modulation frequency	Jitter tolerance						
40 kHz to 4 MHz	5 to 0.05UI						
4 to 160 MHz	0.05UI						

*1: Bit rate: 9.95328 Gbit/s, Pattern: Frame format equal to STM-64
Mark ratio: 1/2, Termination: single end, at 20 to 30°C

*2: Deviation of bit rate of data input signal to the specified bit rate

*3: Guaranteed by design under the following conditions:

- Bit rate: 10.315 Gbit/s
- Pattern: PRBS31
- Single-ended
- Amplitude: 50 mV

Table A.1.2-3 Measurement Function

Item	Specifications
Test pattern	Pseudorandom (PRBS) pattern: Pattern length: 2 ⁷ -1, 2 ⁹ -1, 2 ¹⁵ -1, 2 ²³ -1, 2 ³¹ -1 Logic invertible Data pattern (Programmable Pattern): Pattern length: 2 to 1305600 bits, editable by text editor and sample file available
Warning display	<ul style="list-style-type: none"> • SYNC Loss: Pattern synchronization loss • Error: Bit error
History display	<ul style="list-style-type: none"> • SYNC Loss: Pattern synchronization loss • Error: Bit error
Bit error detection	Detection mode: Total Error, Insertion Error, Omission Error Bit error rate: 0.0001E-18 to 1.0000E-00 Bit error count: 0 to 9999999, 1.0000E07 to 9.9999E17
Regenerating clock detection	Clock count: 0 to 9999999, 1.0000E07 to 9.9999E17 Frequency: Bit rate setting ±100 ppm, Accuracy: ±10 ppm*1
Measurement method	Measurement time: 1 seconds to 9 days 23 hours 59 minutes 59 seconds Measurement frequency: single, repeat, untimed Display update interval*2: 0.1 seconds, set time at measurement time Auto sync control: On, Off Threshold value at bit error rate: INT, 1E-2, 1E-3, 1E-4, 1E-5, 1E-6, 1E-7, 1E-8 Sync control: Frame detection On*3, Off Frame length: 64 bits Frame position: 1 to (Pattern Length – Frame Length + 1) 1 bit resolution
4-channel measurement function *4	Channel tracking: Makes the following settings dependent on Channel 1. <ul style="list-style-type: none"> • Bit rate • PPG pattern • PPG/ED tracking • Measurement mode BER measurement: Collectively starts and stops the measurement for ED1 to ED4. All channel BER result display: Displays the measurement results of ED1 to ED4 at a time.

*1: Measurement accuracy depends on the internal reference clock.

*2: This can be set when measurement cycle is single or repeat

*3: This can be set when test pattern is Programmable Pattern and data length is 128 bits or more.

*4: Only Option 014

A.1.3 Sampling Oscilloscope

Table A.1.3-1 Function

Item	Specifications
Sampling	Sampling Mode: Eye, Pulse, Coherent Eye Number of Sampling: Eye: 509, 1021, 1350, 2039, 4093, 8191, 16381 Pulse, Coherent Eye: 512, 1024, 2048, 4096, 8192, 16384 Sampling can be switched between Run and Hold,
Display	Channel A, Channel B Accumulation Type: Eye: Infinite, Limited Pulse, Coherent Eye: Averaging, Infinite, Limited The trace clear function is available.
Amplitude Settings	Scale, Offset, Attenuation, Channel A/B Tracking
Time Settings	Rate, Scale, Offset, Pattern length
Auto Scale	Automatically adjusts the scale and offset for amplitude and time.
Measurement	Marker: X1, X2, Y1, Y2 Measurement item: Amplitude/Time, Histogram, Mask test
Calculation between channels	Definition formula: Ch A + Ch B, Ch A - Ch B, Ch B - Ch A
File format to save results	File Type: jpg or png (Color inversion available)
Label	Number of characters: Max. 1024
Trace Memory	Channel to save: Channel A, Channel B, Channel A & Channel B
Maintenance	Calibration, Application Test

Table A.1.3-2 Amplitude/Time Measurement

Item	Specifications
Measurement Item*1	One Level, Zero Level, Eye Amplitude, Eye Height, Crossing, SNR, Average Power(dBm)*2, Average Power(mW)*2, Extinction Ratio*2, Jitter p-p, Jitter RMS, Rise Time, Fall Time, Eye Width, DCD, OMA (dBm)*2, OMA (mW)*2
Target Channel	Channel A or Channel B
Display Item	Channel, Current value, Mean, Standard deviation, Minimum value, Maximum value
Measurement condition	Eye Boundary Offset from Crossing 0 to 1UI (0.01UI step) Width 0 to 1UI (0.01UI step) Rise/Fall Time Percentage 10-90%, 20-80% Correction Factor 0 to 9999.9ps

*1: Up to 4 items can be selected.

*2: Only when an optical channel is selected

Table A.1.3-3 Histogram Measurement

Item	Specifications
Axis	Amplitude, Time
Marker	X1, X2, Y1, Y2
Display Item	Mean, Standard deviation, Peak-to-peak value, the number of hits

Table A.1.3-4 Mask Test

Item	Specifications
For supported mask	1GFC 2GFC 4GFC 8GFC 8GFC_Elect_Tx 8GFC_Elect_Rx 10GFC 10GFC FEC 1GbE 2GbE 10GbE_WAN 10GbE LAN/PHY 10GbE FEC OC48/STM16 OTU-1 OC192/STM64 OC192/STM64 FEC (G.975) OTU-2 1310 nm OTU-2 1550 nm OTU-2 1550 nm Expanded OTU-2 Amplified User defined Mask file (Text file with extension msk, pcm)

Table A.1.3-4 Mask Test (Cont'd)

Item	Specifications
Mask Margin Test	One Shot, Continuous
Mask Alignment	Auto: Zero/One/Crossing User Defined: X1, ΔX, Y1, ΔY marker
Mask Display	ON/OFF
Margin Measurement	Mask Margin: -100 to +100% Fail criteria (The number of failed samples) 1 to 999999999 (1 step) Mask Area Restriction: ON/OFF Angle -90 to 90° (1° step) Width 0.01 to 1 UI (0.01 step)
Result Display	Total Samples, Total Waveforms, Mask Margin [%], Target Failed Sample, Total Failed Samples, Top Mask Failed Samples, Center Mask Failed Samples, Bottom Mask Failed Samples

Table A.1.3-5 Horizontal System

Item	Specifications
Clock Trigger Input	Connector: SMA jack Termination: 50 Ω Frequency: 0.1 to 12.5 GHz Sensitivity: 100 mVp·p*1 Absolute maximum input: 2 Vp·p*2 Jitter, RMS: 5 to 12.5 GHz: Typ. 0.85 ps, Max. 1.35 ps 1 to 5 GHz: Typ. 1.0 ps, Max. 1.5 ps 0.1 to 1 GHz: Typ. 2.0 ps, Max. 2.5 ps
Scale	Eye pattern: 1UI or more in full scale Pulse pattern: 1 bit or more in full scale

*1: Typical value

*2: Design guaranteed

Table A.1.3-6 Vertical System

Item	Specifications
Electrical input	Data input: Option 021: CH A, CH B, Option 023: CH A Input connector: K Termination: 50 Ω Absolute maximum input: ±2 V* ¹ Input range Offset: ±500 mV max. Dynamic range: ±400 mV max. Bandwidth (–3 dB): DC to 20 GHz min. DC to 25 GHz* ² Flatness: ±1 dB* ² RMS noise: 1.75 mV _{rms} max. 0.5 mV _{rms} * ²

*1: Design guaranteed

*2: Typical value

Table A.1.3-6 Vertical System (Cont'd)

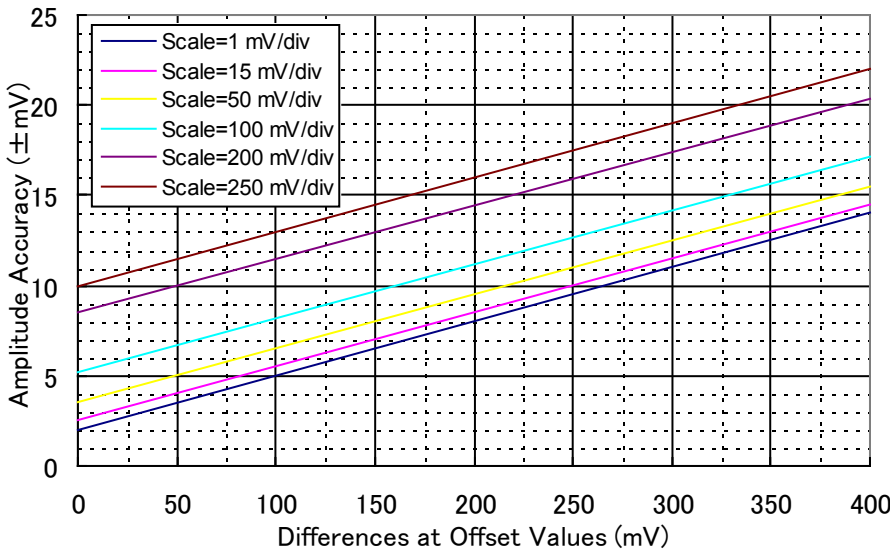
Item	Specifications
Electrical input (Cont'd)	<p>Amplitude accuracy*3</p> <p>\pmamplitude accuracy $\pm 2\%$ for reading value*4</p> <p>The following figure shows the amplitude accuracy after calibration.</p>  <p>The graph plots Amplitude Accuracy (±mV) on the y-axis (0 to 25) against Differences at Offset Values (mV) on the x-axis (0 to 400). Six lines represent different scales: 1 mV/div (blue), 15 mV/div (magenta), 50 mV/div (yellow), 100 mV/div (cyan), 200 mV/div (purple), and 250 mV/div (red). All lines show a positive linear relationship, with higher scales resulting in higher amplitude accuracy values for the same offset.</p>

*3: After internal calibration

*4: Calculation example: At 400 mV amplitude reading value and 50 mV offset voltage

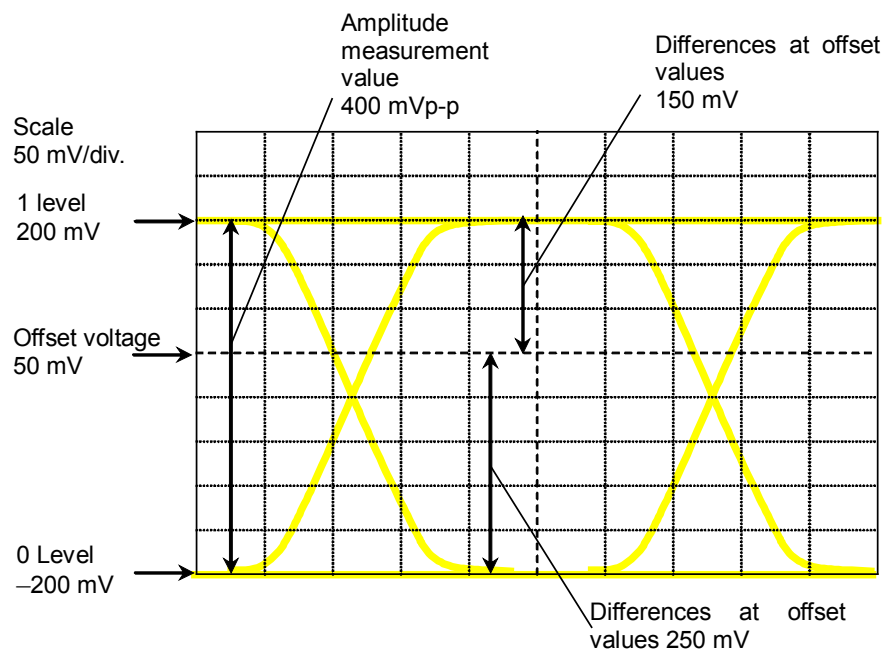

In this example, the difference between 1 level voltage (200 mV) and offset voltage (50 mV) is 150 mV. At a scale of 50 mV/div for a voltage difference of 150 mV, the amplitude accuracy is 8 mV. At 1 level accuracy, the difference is calculated as follows:

$$200 \times 2\% + 8 = 12 \quad \pm 12 \text{ mV}$$

The difference between 0 level voltage (-200 mV) and offset voltage (50 mV) is 250 mV.

At the 50 mV/div scale for a voltage difference of 250 mV, the amplitude accuracy is 11 mV. At 0 level accuracy, the difference is calculated as follows:

$$200 \times 2\% + 11 = 15 \quad \pm 15 \text{ mV}$$

Table A.1.3-6 Vertical System (Cont'd)

Item	Specifications																																													
Optical input*5	Data input Option 023: CH B																																													
	Connector FC*6, SC*7																																													
	Suitable fiber Single mode fiber, multi-mode fiber (62.5 μm)*8																																													
	Wavelength range 750 to 1650 nm																																													
	Bandwidth*9 DC to 9.0 GHz																																													
	Optical noise*2 (Unit:μWrms)																																													
	<table border="1" style="width: 100%; border-collapse: collapse;"> <thead> <tr> <th rowspan="2" style="text-align: center;">Wavelength Installed Filter</th> <th colspan="2" style="text-align: center;">850 nm</th> <th colspan="2" style="text-align: center;">1310, 1550 nm</th> </tr> <tr> <th style="text-align: center;">Typ.</th> <th style="text-align: center;">Max.</th> <th style="text-align: center;">Typ.</th> <th style="text-align: center;">Max.</th> </tr> </thead> <tbody> <tr> <td style="text-align: center;">Option 070 to 073, 075</td> <td style="text-align: center;">3.1</td> <td style="text-align: center;">5.3</td> <td style="text-align: center;">1.8</td> <td style="text-align: center;">3.1</td> </tr> <tr> <td style="text-align: center;">Option 076, 077 to 080</td> <td style="text-align: center;">2.7</td> <td style="text-align: center;">4.6</td> <td style="text-align: center;">1.5</td> <td style="text-align: center;">2.7</td> </tr> <tr> <td style="text-align: center;">Option 081 to 083</td> <td style="text-align: center;">3.9</td> <td style="text-align: center;">6.3</td> <td style="text-align: center;">2.2</td> <td style="text-align: center;">3.7</td> </tr> <tr> <td style="text-align: center;">Option 084 to 085</td> <td style="text-align: center;">4.8</td> <td style="text-align: center;">7.7</td> <td style="text-align: center;">2.8</td> <td style="text-align: center;">4.5</td> </tr> <tr> <td style="text-align: center;">Option 086</td> <td></td> <td></td> <td></td> <td></td> </tr> <tr> <td style="text-align: center;"> 9.9≤bitrate≤10.5 Gbit/s</td> <td style="text-align: center;">2.4</td> <td style="text-align: center;">3.8</td> <td style="text-align: center;">1.3</td> <td style="text-align: center;">2.2</td> </tr> <tr> <td style="text-align: center;"> 10.5<bitrate≤11.3 Gbit/s</td> <td style="text-align: center;">2.5</td> <td style="text-align: center;">4.1</td> <td style="text-align: center;">1.4</td> <td style="text-align: center;">2.4</td> </tr> </tbody> </table>		Wavelength Installed Filter	850 nm		1310, 1550 nm		Typ.	Max.	Typ.	Max.	Option 070 to 073, 075	3.1	5.3	1.8	3.1	Option 076, 077 to 080	2.7	4.6	1.5	2.7	Option 081 to 083	3.9	6.3	2.2	3.7	Option 084 to 085	4.8	7.7	2.8	4.5	Option 086					9.9≤bitrate≤10.5 Gbit/s	2.4	3.8	1.3	2.2	10.5<bitrate≤11.3 Gbit/s	2.5	4.1	1.4	2.4
	Wavelength Installed Filter	850 nm		1310, 1550 nm																																										
		Typ.	Max.	Typ.	Max.																																									
	Option 070 to 073, 075	3.1	5.3	1.8	3.1																																									
	Option 076, 077 to 080	2.7	4.6	1.5	2.7																																									
	Option 081 to 083	3.9	6.3	2.2	3.7																																									
	Option 084 to 085	4.8	7.7	2.8	4.5																																									
	Option 086																																													
	9.9≤bitrate≤10.5 Gbit/s	2.4	3.8	1.3	2.2																																									
10.5<bitrate≤11.3 Gbit/s	2.5	4.1	1.4	2.4																																										
Sensitivity*2,*10																																														
<table border="1" style="width: 100%; border-collapse: collapse;"> <tbody> <tr> <td style="width: 70%;">When using a filter other than Option 086</td> <td style="text-align: center;">-12 dBm</td> </tr> <tr> <td style="width: 70%;">When using a filter of Option 086</td> <td></td> </tr> <tr> <td style="padding-left: 20px;">9.9≤bitrate≤10.5 Gbit/s</td> <td style="text-align: center;">-15 dBm</td> </tr> <tr> <td style="padding-left: 20px;">10.5≤bitrate (Gbit/s)</td> <td style="text-align: center;">-14.4 dBm</td> </tr> </tbody> </table>		When using a filter other than Option 086	-12 dBm	When using a filter of Option 086		9.9≤bitrate≤10.5 Gbit/s	-15 dBm	10.5≤bitrate (Gbit/s)	-14.4 dBm																																					
When using a filter other than Option 086	-12 dBm																																													
When using a filter of Option 086																																														
9.9≤bitrate≤10.5 Gbit/s	-15 dBm																																													
10.5≤bitrate (Gbit/s)	-14.4 dBm																																													
Maximum input power*11:	Average power -1 dBm (794 μW) Peak power +2 dBm (1.58 mW)																																													
Absolute maximum power:	Peak power +5 dBm (3.16 mW)																																													
Optical power measurement:	Range -18 to 0 dBm Accuracy: ±0.35 dB*2 -12 dBm or more ±0.6 dB*2 less than -12 dBm																																													
Optical return loss	-30 dB*2																																													

*5: Option 023 CH B only

*6: Option 037

*7: Option 040

*8: Single mode fiber acceptable

*9: No internal filter, Frequency that electrical output level goes -3 dB down, typical value

*10: Mask test available range

*11: Level that is considered to be an overload

Table A.1.3-7 Digital System

Item	Specifications
Sampling speed	100 k sample/second* ¹
Fast sampling rate mode	Effective sampling speed: 150 k sample/second* ² Number of samples: Eye pattern 509, 1021, 1350, 2039, 4093, 8191, 16381 Accumulation type: Infinite, Limited Bit on screen: 1 to 100, 1 bit step

*1: Nominal value

*2: Sampling mode: Eye, The number of samples: 1350, Bit on screen: 2

Table A.1.3-8 Clock Recovery

Item	Specifications
Clock Recovery (MP2100B-053)	CRU Input Sensitivity: 100 mVp-p* ¹ Maximum Amplitude: 2 Vp-p CRU Output Connector: SMA jack Termination: AC coupling, 50 Ω Amplitude: 0.1 to 2.7 GHz: 270 to 540 mVp-p 8.5 to 12.5 GHz: 500 to 1500 mVp-p Frequency: 8.5 to 12.5 GHz, 0.1 to 2.7 GHz Jitter (RMS): 8.5 to 12.5 GHz: 20 mUI or less* ² , 10 mUI* ¹ , * ² 0.1 to 2.7 GHz: 5 mUI or less Loop bandwidth: 8.5 to 12.5 GHz Band: 1, 2, 4, 8 MHz* ³ 0.1 to 2.7 GHz Band 2488.32 MHz: 200 kHz* ³ 622 MHz: 50 kHz* ³ 156 MHz: 20 kHz* ³
Clock Recovery (MP2100B-054)	CRU Input Connector: Common for O/E Data In (Ch B) Sensitivity: When option x70 to x82 is installed -9 dBm* ¹ When option x86 is installed 9.9 to 10.5 Gbit/s -12 dBm* ¹ 10.5 Gbit/s or higher -11.4 dBm* ¹ Maximum Amplitude: Before overload -1 dBm or 794 μW (average) +2 dBm or 1.58 mW (peak) Before damage +5 dBm or 3.16 mW (peak) The specifications for the following are the same as MP2100B-053: Clock output, Frequency, Jitter (RMS), Loop bandwidth
Clock Recovery (MP2100B-055)	CRU Input Connector: Common for ED1 Data CRU In) Sensitivity, Maximum Amplitude: Refer to “Sensitivity” and “Amplitude” in Table A.1.2-1. The specifications for the following are the same as MP2100B-053: Clock output, Frequency, Jitter (RMS), Loop bandwidth

*1: Typical values

*2: Loop bandwidth: 4 MHz

*3: Nominal values

Table A.1.3-9 Filter

Item	Specifications
High Rate Filter Bank (MP2100B-063)	Filter configuration Up to four filters four of MP2100B-076 to 086 can be installed.
Low Rate Filter Bank (MP2100B-065)	Filter configuration Up to four sets of the following can be installed: MP2100B-070 to MP2100B-073, and MP2100B-075
Multi Rate Filter Bank (MP2100B-069)	Filter configuration Up to three sets of MP2100B-076 to MP2100B-086 and up to three sets of MP2100B-070 to MP2100B-073, and MP2100B-075 can be installed.
LPF for 156M (L) (MP2100B-070)	3 dB cutoff frequency: 116 MHz* 155 Mbit/s Low-pass filter for OC-3/STM-1
LPF for 622M (L) (MP2100B-071)	3 dB cutoff frequency: 470 MHz* 622 Mbit/s Low-pass filter for OC-12/STM-4, CPRI
LPF for 1.0G (L) (MP2100B-072)	3 dB cutoff frequency: 800 MHz* 1062.5 Mbit/s Low-pass filter for 1GFC
LPF for 1.2G (L) (MP2100B-073)	3 dB cutoff frequency: 940 MHz* 1.2 Gbit/s Low-pass filter for 1GbE, OC-24, CPRI x 2
LPF for 2.5G (L) (MP2100B-075)	3 dB cutoff frequency: 1.87 GHz* 2.5 Gbit/s Low-pass filter for CPRI x 4, OC-48/STM-16, 2GbE, Infiniband
LPF for 2.1G (H) (MP2100B-076)	3 dB cutoff frequency: 1.6 GHz* 2.1 Gbit/s Low-pass filter for 2GFC
LPF for 2.6G (H) (MP2100B-078)	3 dB cutoff frequency: 2.0 GHz* 2.6 Gbit/s Low-pass filter for OTU-1
LPF for 3.1G (H) (MP2100B-079)	3 dB cutoff frequency: 2.37 GHz* 3.1 Gbit/s Low-pass filter for CPRI x 5, 10GBASE-LX4, 10GFC-LX4
LPF for 4.2G (H) (MP2100B-080)	3 dB cutoff frequency: 3.2 GHz* 4.2 Gbit/s Low-pass filter for 4GFC
LPF for 5.0G (H) (MP2100B-081)	3 dB cutoff frequency: 3.75 GHz* 5.0 Gbit/s Low-pass filter for Infiniband x 2, CPRI x 8
LPF for 6.2G (H) (MP2100B-082)	3 dB cutoff frequency: 4.61 GHz* 6.2 Gbit/s Low-pass filter for CPRI x 10, XAUI Optical x 2
LPF for Multi 10G (8.5G to 11.3G) (H) (MP2100B-086)	3 dB cutoff frequency: 7.5 GHz* 9.9 to 10.7Gbit/s Low-pass filter for 8GFC, 10GbE WAN, 10GbE LAN/PHY, OC-192/STM-64, Infiniband x 4, 10GFC, G.975 FEC, OTU-2

*: Typical

Table A.1.3-9 Filter (Cont'd)

Item	Specifications
Filter Bank Set (622M/1.2G/2.5G/4.2G /6.2G/ Multi 10G) (MP2100B-087)	Refer to MP2100B-071, MP2100B-073, MP2100B-075, MP2100B-080, MP2100B-082 and MP2100B-086
Filter Bank Set (4.2G/5.0G/6.2G/ Multi 10G) (MP2100B-088)	Refer to MP2100B-080, MP2100B-081, MP2100B-082 and MP2100B-086
Filter Bank Set (156M/622M/1.2G/2.5 G) (MP2100B-089)	Refer to MP2100B-070, MP2100B-071, MP2100B-073 and MP2100B-075

A.1.4 General Performance

Table A.1.4-1 General Performance

Item	Specifications
Panel	Input functions: Rotary , touch panel, power switch
Display	12.1 inch LCD: WXGA (1280 × 800) LED: Disk access, standby, power
Function	Measurement buzzer, panel lock, file save/load, screen copy, system alarm, initialization, block diagram display, minimization of application window, OS recovery
Peripheral Devices connection	VGA output (SVGA), Digital Video Interface, USB 2.0 × 4
Remote interface	Ethernet × 2 (10/100/1000BASE-T) GPIB × 1*1
OS	Windows Embedded Standard 2009*2
Internal storage devices	Flash Memory Drive, 8 GB or more
Power source	Power voltage: AC 100 to 120 V, 200 to 240 V (Auto switch: 100/200 V)*3 Frequency: 50 Hz to 60 Hz Power consumption: 300 VA or less
Environment performance	Operating temperature: +5 to +40°C Storage temperature: -20 to +60°C EMC: EN61326-1, EN61000-3-2 LVD: EN61010-1
Size and mass	Dimensions: 221.5 (H) × 341 (W) × 180 (D) mm (excluding protrusions) Weight: 7 kg max. (When with the Options 012 and 021. Other options are not included.)

*1: Option 030 required

*2: Operation not warranted when software installed after factory shipment

*3: Operating voltage: within the range of +10 to -15% from the rated voltage

A.2 Optical Transceiver Module

Table A.2-1 850 nm SFP

Item		Specifications
Model/Product Name		G0177A 850 nm SFP Module
Bit rate		1.062 to 4.25 Gbit/s
Transmitter* ¹	Output Laser safety class Center wavelength RMS Spectrum width OMA Suitable optical fiber Connector Eye mask pattern	-9.0 to -2.5 dBm IEC60825-1: Class 1 Class I (FDA 21 CFR 1040.10) 830 to 860 nm 0.85 nm or less 247 μW or more* ² GI (50/125 μm), GI (62.5/125 μm) LC/PC {X1, X2, Y1, Y2} {0.22, 0.4, 0.2, 0.3}* ²
Receiver* ¹	Wavelength range Sensitivity Maximum input Suitable optical fiber Connector LOS detection level Rate Select Setting	830 to 860 nm -15.0 dBm or less* ³ 0.0 dBm* ³ GI (50/125 μm), GI (62.5/125 μm) LC/PC -20.0 dBm or less Available

*1: Pattern: PRBS2²³-1, Mark ratio: 1/2, Bit rate: 4.25 Gbit/s

*2: Using the filter for 4.25 Gbit/s

*3: Average power, BER ≤ 10⁻¹⁰

Table A.2-2 1310 nm SFP

Item		Specifications
Model/Product Name		G0178A 1310 nm SFP Module
Bit rate		0.15 to 2.67 Gbit/s
Transmitter*1	Output Laser safety class Center wavelength SMSR Extinction Ratio Suitable optical fiber Connector Eye mask pattern	-5.0 to 0.0 dBm IEC60825-1: Class 1 Class I (FDA 21 CFR 1040.10) 1270 to 1360 nm 30.0 dB or more 8.2 dB or more*2 Single mode fiber (ITU-T G.652) LC/PC {X1, Y1} {0.4,0.25}*2
Receiver*1	Wavelength range Sensitivity Maximum input Suitable optical fiber Connector LOS detection level Rate Select Setting	1270 to 1360 nm -18.0 dBm or less*3 0.0 dBm*3 Single mode fiber (ITU-T G.652) LC/PC -18.0 dBm or less Available

*1: Pattern: PRBS²³-1, Mark ratio: 1/2, Bit rate: 2.488 Gbit/s
 *2: Using the filter for 2.488 Gbit/s
 *3: Average power, BER ≤ 10⁻¹⁰

Table A.2-3 1550 nm SFP

Item		Specifications
Model/Product Name		G0179A 1550 nm SFP Module
Bit rate		0.15 to 2.67 Gbit/s
Transmitter* ¹	Output Laser safety class Center wavelength SMSR Extinction Ratio Suitable optical fiber Connector Eye mask pattern	-5.0 to 0.0 dBm IEC60825-1: Class 1 Class I (FDA 21 CFR 1040.10) 1430 to 1590 nm 30.0 dB or more 8.2 dB or more* ² Single mode fiber (ITU-T G.652) LC/PC {X1, Y1} {0.4,0.25}* ²
		<p style="text-align: center;">Normalized Time (Unit Interval)</p>
Receiver* ¹	Wavelength range Sensitivity Maximum input Suitable optical fiber Connector LOS detection level Rate Select Setting	1430 to 1580 nm -18.0 dBm or less* ³ 0.0 dBm* ³ Single mode fiber (ITU-T G.652) LC/PC -18.0 dBm or less Not available

*1: Pattern: PRBS2²³-1, Mark ratio: 1/2, Bit rate: 2.488 Gbit/s
 *2: Using the filter for 2.488 Gbit/s
 *3: Average power, BER ≤ 10⁻¹⁰

Table A.2-4 850 nm SFP+

Item		Specifications
Model/Product Name		G0238A 850 nm SFP+ Module
Bit rate		10.3125 Gbit/s
Transmitter* ¹	Output	-5.0 to -1.0 dBm
	Laser safety class	IEC60825-1: Class 1 21 CFR 1040.10: Class I
	Center wavelength	840 to 860 nm
	RMS Spectrum width	0.45 nm or less
	Extinction Ratio	3.0 dB or more* ²
	Suitable optical fiber	GI (50/125 μm), GI (62.5/125 μm)
	Connector	LC/PC
	Eye mask pattern	{X1, X2, X3, Y1, Y2, Y3} {0.25, 0.40, 0.45, 0.25, 0.28, 0.40}* ²
Receiver* ¹	Wavelength range	840 to 860 nm
	Sensitivity	-11.1 dBm or less* ³
	Maximum input	0.5 dBm* ⁴
	Suitable optical fiber	GI (50/125 μm), GI (62.5/125 μm)
	Connector	LC/PC
	LOS detection level	-12.0 dBm or less, -20.0 dBm* ⁵

*1: NRZ signal: PRBS2²³-1, mark ratio: 1/2, bit rate: 10.3125 Gbit/s

*2: Uses 10.3125 Gbit/s filter

*3: Optical Modulation Amplitude, BER ≤10⁻¹², at 20 to 30°C

*4: Average power, BER ≤10⁻¹², at 20 to 30°C

*5: Typical values

Table A.2-5 1310 nm SFP+

Item		Specifications
Model/Product Name		G0239A 1310 nm SFP+ Module
Bit rate		9.95328 to 10.3125 Gbit/s
Transmitter* ¹	Output Laser safety class Center wavelength SMSR Extinction Ratio Suitable optical fiber Connector Eye mask pattern	-8.2 to 0.5 dBm IEC60825-1: Class 1 21 CFR 1040.10: Class I 1260 to 1355 nm 30.0 dB or more 3.5 dB or more* ² Single mode fiber (ITU-T G.652) LC/PC {X1, X2, X3, Y1, Y2, Y3} {0.25, 0.40, 0.45, 0.25, 0.28, 0.40}* ²
Receiver* ¹	Wavelength range Sensitivity Maximum input Suitable optical fiber Connector LOS detection level	1260 to 1355 nm -12.6 dBm or less* ³ 0.5 dBm* ⁴ Single mode fiber (ITU-T G.652) LC/PC -30.0 dBm or more

*1: NRZ signal: PRBS²³-1, mark ratio: 1/2, bit rate: 10.3125 Gbit/s

*2: Uses 10.3125 Gbit/s filter

*3: Optical Modulation Amplitude, BER ≤ 10⁻¹², at 20 to 30°C

*4: Average power, BER ≤ 10⁻¹², at 20 to 30°C

Appendix B Initial Values

Table B-1 Initial Values of PPG/ED

Item	Initial Value
Ch Tracking	On
Reference CLK	Ch1, Ch3: Internal 10 MHz Ch2, Ch4: Ch1
Sync Output	PPG1_1/4Clk

Table B-2 Initial Values of PPG

Item	Initial Value
Data/XData	Off
Bit Rate Standard	Variable
Bit Rate	8500000 kbit/s
Bit Rate Offset	0 ppm
Amplitude	0.40 Vp-p
External ATT	0 dB
Test Pattern	PRBS 2 ⁹ -1
Programmable Pattern	"-----"
Test Pattern Logic	POS
Error Addition	Off
Error Addition Rate	Repeat
Error Rate	1E-2

Table B-3 Initial Values of ED

Item	Initial Value
Tracking	ON
Bit Rate Standard	Variable
Bit Rate	8500000 kbit/s
Data Input Condition	Electrical Single-Ended-Data
Data Input Condition Threshold	0 mV
External ATT	0 dB
Test Pattern	PRBS 2 ⁹ -1
Programmable Pattern	"-----"
Test Pattern Logic	POS
Auto SYNC	ON
Auto SYNC Threshold	INT
SYNC Control	OFF
Frame Position	1
Gating Cycle	Repeat
Gating Current	ON
Gating Period	1 S
ED Result	"Total"
Result Time	Start Time
Start/Stop	Stop

Table B-4 Initial Values of Sampling Oscilloscope (EYE/Pulse Scope)

Item	Initial Value
Amplitude	
Attenuation A	0 dB
Attenuation B	0 dB
Channel A/B Tracking	Off
Channel Math	Off
Define Function	CHA+CHB
Scale	*1
Offset	0 mV
Offset A	0 mV
Offset B	0 mV* ² 0 μ W* ³
Scale A	*1
Scale B	*1
CH A	On
CH B	On
Marker Disp	Off
X1	Off
X2	Off
Y1	Off
Y2	Off

*1: No initial value is provided.

*2: When Option 021 is installed

*3: When Option 023 is installed

Table B-4 Initial Values of Sampling Oscilloscope (Cont'd)

Item	Initial Value
Measure	
Active Channel Selection	Channel A
Measurement Item	Off
Amplitude/Time	
Correction Factor	0 ps
Item	1
Item Selection	(Ch.A) Jitter p-p (Ch.A) Jitter RMS (Ch.A) Crossing (Ch.A) Eye Amplitude
Measuring Area Marker	Off
Offset form Crossing	0.50 UI
Rise/Fall Time	20/80%
Rise/Fall Time Correction	Off
Width	0.20 UI
Histogram	
Axis	Amplitude
X1	0.50 UI
X2	1.50 UI
Y1	100 mV
Y2	-100 mV

Table B-4 Initial Values of Sampling Oscilloscope (Cont'd)

Item		Initial Value
Measure (Cont'd)		
	Measurement Item	Off
	Mask Test	
	Align Marker	Display Off
	X1	0.50
	ΔX	1.00
	Y1	*1
	ΔY	*1
	Align Method	Zero/One/Crossing
	Eye Mask Select	1GFC
	Mask Area Restriction	Off
	Angle	0
	Width	0.10 UI
	Mask Margin	One Shot
	Mask Margin	0%
	Target Failed	1

Table B-4 Initial Values of Sampling Oscilloscope (Cont'd)

Item	Initial Value
Setup	
Accumulation Type	Persistency
Averaging	10 wfms
Clock Recovery	Off
CRU Loop BW	1 MHz
Fast Sampling Mode	On
Inverse background color	Off
Limit Type	Time
Number of Samples	8191
Ref. Trace Channel	Ch A & Ch B
Samples	10 million
Sampling Mode	Eye
Fast Sampling Mode	On
Time	10.0 sec
Waveforms	100 wfms
Waveforms Only	Off
Time	
Bits on Screen	2
Clock Rate	2 125 000 kHz
Bit Rate	8 500 000 kbit/s
Divide Ratio	4
Divide Ratio Detect	Off
Length	511
Master (Data Clock Rate)	PPG1
Master (Pattern Length)	PPG1
Offset	0
Recalculate Option	Clock Rate
Skew	
Channel A	0.0
Channel B	0.0
Tracking (Data Clock Rate)	Off
Tracking (Pattern Length)	Off
Unit	UI

Table B-5 Initial Values of Optical Transceiver (SFP+)

Item	Initial Value
Output	Off

Table B-6 Initial Values of O/E Converter

Item	Initial Value
Filter On/Off* ¹	On
Conversion Gain	0
Extinction Ratio Correction	Off
Extinction Ratio Correction Factor	0
Filter	* ³
Responsivity	* ²
System Conversion Gain	* ²
Wavelength	1550
Input Power	-7.00 dBm

*1: When Option 086 installed

*2: This value has been set at the factory to achieve 1550 nm wavelength, and is different from one BERTWave to another.

*3: This indicates the lowest bit rate filter in the filters installed.

Table B-7 Initial Values of Setup Utility

Item	Initial Value
Remote Control	
Active Interface	Ethernet
Protect	OFF
GPIB*	
Address	1
Ethernet	
Local Area Connection (Upper)	
IP Address	192 168 100 101
Subnet Mask	255 255 255 0
Gateway	
Local Area Connection (Lower)	
IP Address	192 168 100 102
Subnet Mask	255 255 255 0
Gateway	
Port Number	5001

*: When Option 030 installed

Appendix C Keyboard and Mouse Operations

The operation of the rotary knob, arrow keys displayed on the screen, numeric input panel, and buttons in dialogue boxes and the corresponding keyboard and mouse operations are explained below.

Table C-1 Correspondence between Rotary Knob Operation and Keyboard

Rotary Knob Operation	Keyboard
Rotary Knob Counterclockwise rotation	Shift + Tab
Rotary Knob Clockwise rotation	Tab
Pressing Rotary Knob	Enter

Table C-2 Correspondence between Panel Keys and Keyboard

Panel Key	Keyboard
0	0
1	1
2	2
3	3
4	4
5	5
6	6
7	7
8	8
9	9
+	+
-	-
.(Period)	.(Period)
▲	↑
>	→
▼	↓
<	←
OK	Enter
Cancel	ESC
<<,BKSP	Back Space

Panel operations using the keyboard at the Setup Utility are not supported.

Table C-3 Corresponding to Mouse Operation

Mouse Operation	Corresponding Operation
Left button click	Same as touching touch panel
Right button click	No operation
Wheel	Same as turning rotary knob ↑Forwards: Clockwise ↓Backwards: Counterclockwise

Appendix D Pattern Files

Appendix D describes the specifications for pattern files and mask files.

D.1	Pattern File Specifications	D-2
D.2	Mask file Specifications	D-4

D.1 Pattern File Specifications

The specifications for data files read as PPG or ED are as follows:

Table D.1-1 Specifications for Data Pattern File

Item	Specifications
Save destination folder	C:\Program Files\Anritsu\MP2100A \MX210000A\UserData\Pattern
File extension	ppf
Data length (bits)	2 to 1305600
Description method	Hexadecimal or binary

Data description specifications

- Data pattern as text file
- Comma-separated (,) data length, description method and data
- Decimal data length description
- HEX descriptor for hexadecimal and BIN for binary
- HEX not case sensitive
- 2-byte characters not supported
- Ignores spaces, line breaks and tabs
- Errors occur under following conditions:
 - One or less commas (,) included in file
 - Data longer than 10000000 bits
 - 2-byte characters included in file
- Ignores data after third comma when 3 or more commas (,) included in file
- Displays warning when reading 1305601 or more bits of data
In this case, pattern only uses data from header to bit 1305600.
- Pads missing part with 0s when described data bit count smaller than data length
- Uses data up to data length for pattern when described data bit count larger than data length
- Sets data to all 0s when data description omitted

Hexadecimal description specifications

- Hexadecimal description only as integer values with no decimals
- Data length in multiples of 4
- Supports mixture of upper- and lower-case characters A to F (case insensitive)
- File read error when data includes characters other than A, B, C, D, E, F, a, b, c, d, e, and f

Binary description specifications

- Binary description only as integer values with no decimals
- File read error if data includes characters other than 0 and 1

Example of pattern file

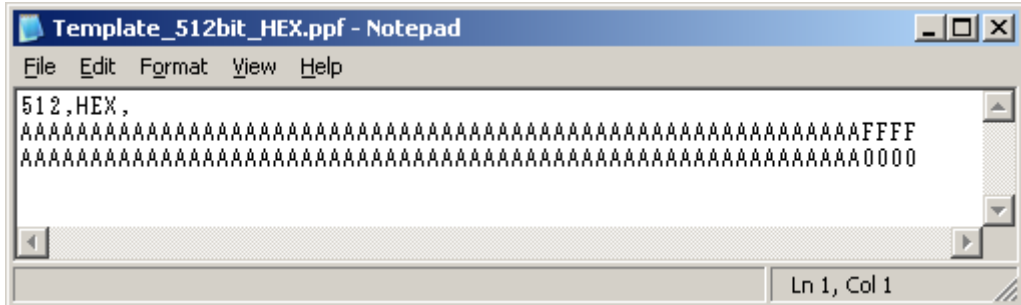

Figure D.1-1 Example of Pattern File Described by Hexadecimal Number

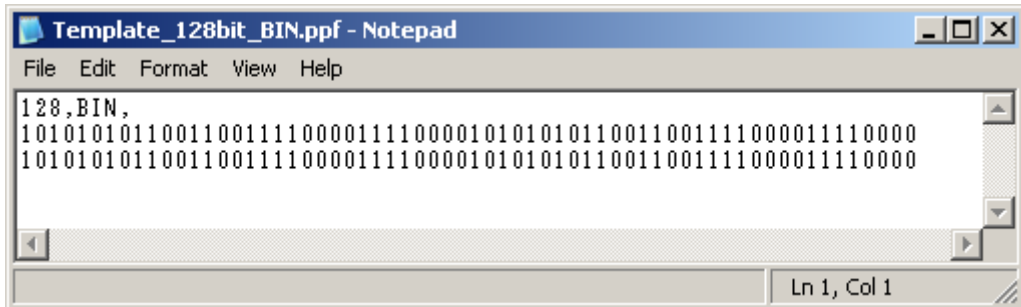

Figure D.1-2 Example of Pattern File Described by Binary Number

D.2 Mask file Specifications

The mask file specifications reading with Sampling Scope is as follows.

Table D.2-1 Mask File Specifications

Item	Specification
Save folder	C:\Program Files\Anritsu\MP2100A \MX210000A\UserData\Mask
File extension	txt

The mask file is the test format file.

The mask margin 0, -100 and 100% of the top mask of the coordinate value are described to the file.

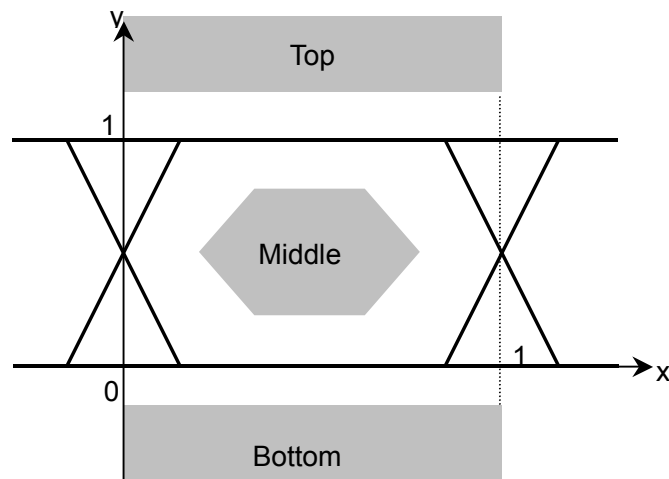

Figure D.2-1 Coordinate System of Mask

The following items are described in the mask file.

Table D.2-2 Details of Mask File

Item	Parameter to be set	Description
Version	Masks Version#1	Make sure that the version is written.
Mask name	Mask name	Mask name displayed on the measurement screen.
Mask type	Relative Mask Fixed Mask	Relative: Sets coordinate of amplitude direction by rate. The Mask coordinate varies with the amplitude of input signal. Fixed: Sets coordinate of amplitude direction at the fixed value. The Mask coordinate does not vary with the amplitude of input signal.
Coordinates in the top	TOP X Y X_min Y_min X_max Y_max	Specifies each X and Y coordinate in the area of Top/Middle/Bottom.
Coordinates in the middle	MIDDLE X Y X_min Y_min X_max Y_max	As for X_min and Y_min, set the coordinate at 100% of Mask Margin.
Coordinates in the bottom	BOTTOM X Y Y_min X_max Y_max	As for X_max, and Y_max, set the coordinate at -100% of Mask Margin. The coordinate can be set up to 10 points. If it is not used, set “-1”.

```

>>>>>>>>> START >>>>>>>>>
Masks Version#1
<1GFC ; 1G Optical Fibre Channel Mask (1.0625 Gbps)> Relative Mask;

Top      X      Y      X_min  Y_min  X_max  Y_max
         0      99      0      99      0      99
         0      1.3    0      1.6    0      1
         1      1.3    1      1.6    1      1
         1      99      1      99      1      999
        -1     -1     -1     -1     -1     -1
        -1     -1     -1     -1     -1     -1
        -1     -1     -1     -1     -1     -1
        -1     -1     -1     -1     -1     -1
        -1     -1     -1     -1     -1     -1
        -1     -1     -1     -1     -1     -1
Middle   X      Y      X_min  Y_min  X_max  Y_max
         0.215  0.5    0.5    0.5    0      0.5
         0.4    0.8    0.5    0.5    0.4    1
         0.6    0.8    0.5    0.5    0.6    1
         0.785  0.5    0.5    0.5    1      0.5
         0.6    0.2    0.5    0.5    0.6    0
         0.4    0.2    0.5    0.5    0.4    0
        -1     -1     -1     -1     -1     -1
        -1     -1     -1     -1     -1     -1
        -1     -1     -1     -1     -1     -1
        -1     -1     -1     -1     -1     -1
Bottom   X      Y      X_min  Y_min  X_max  Y_max
         0     -99     0     -99     0     -99
         0     -0.2    0     -0.4    0      0
         1     -0.2    1     -0.4    1      0
         1     -99     1     -99     1     -99
        -1     -1     -1     -1     -1     -1
        -1     -1     -1     -1     -1     -1
        -1     -1     -1     -1     -1     -1
        -1     -1     -1     -1     -1     -1
        -1     -1     -1     -1     -1     -1
        -1     -1     -1     -1     -1     -1
>>>>>>>>> END >>>>>>>>>

```

Figure D.2-2 Coordinate System of Mask

Appendix E Performance Test Record Form

Document number: _____

Test Location: _____

Date: _____

Test person in charge: _____

Product name: _____

Serial number: _____

Software version: _____

Option: _____

Power voltage: _____ V

Power frequency: _____ Hz

Ambient temperature _____ °C

Relative humidity _____ %

Instruments used: Model name Serial number _____

 Model name Serial number _____

 Model name Serial number _____

 Model name Serial number _____

Remarks _____

E.1 Pulse Pattern Generator

Table E.1-1 Pulse Pattern Generator Performance Test Record Form (Without Option 092)

Measurement Channel PPG 1 2 3 4						
Frequency Accuracy						
Connector	Set Bit Rate (kbit/s)	Minimum Value (kHz)	Measured Value (kHz)	Maximum Value (kHz)	Measurement Uncertainty	Pass/Fail
Data Out	11320000	11319887		11320113		Pass/Fail
	132813	132800		132826		Pass/Fail
Data Out	11320000	11319887		11320113		Pass/Fail
	132813	132800		132826		Pass/Fail
Waveform (Amplitude)						
Connector	Set Amplitude	Minimum Value	Measured Value	Maximum Value	Measurement Uncertainty	Pass/Fail
Data Out	0.1 V _{p-p}	0.06 V _{p-p}	V _{p-p}	0.14 V _{p-p}		Pass/Fail
	0.8 V _{p-p}	0.62 V _{p-p}	V _{p-p}	0.98 V _{p-p}		Pass/Fail
Data Out	0.1 V _{p-p}	0.06 V _{p-p}	V _{p-p}	0.14 V _{p-p}		Pass/Fail
	0.8 V _{p-p}	0.62 V _{p-p}	V _{p-p}	0.98 V _{p-p}		Pass/Fail
Waveform						
Connector	Item	Minimum Value	Measured Value	Maximum Value	Measurement Uncertainty	Pass/Fail
Data Out	Crossing	40%	%	60%		Pass/Fail
	Rise Time		ps	28 ps		Pass/Fail
	Fall Time		ps	28 ps		Pass/Fail
	Jitter (rms)		ps	2 ps		Pass/Fail
Data Out	Crossing	40%	%	60%		Pass/Fail
	Rise Time		ps	28 ps		Pass/Fail
	Fall Time		ps	28 ps		Pass/Fail
	Jitter (rms)		ps	2 ps		Pass/Fail

Table E.1-2 Pulse Pattern Generator Performance Test Record Form (With Option 092)

Measurement Channel PPG 1 2 3 4						
Frequency Accuracy						
Connector	Set Bit Rate (kbit/s)	Minimum Value (kHz)	Measured Value (kHz)	Maximum Value (kHz)	Measurement Uncertainty	Pass/Fail
Data Out	12500000	12499875		12500125		Pass/Fail
	125000	124998.75		125001.25		Pass/Fail
Data Out	12500000	12499875		12500125		Pass/Fail
	125000	124998.75		125001.25		Pass/Fail
Waveform (Amplitude)						
Connector	Set Amplitude	Minimum Value	Measured Value	Maximum Value	Measurement Uncertainty	Pass/Fail
Data Out	0.1 V _{p-p}	0.06 V _{p-p}	V _{p-p}	0.14 V _{p-p}		Pass/Fail
	0.8 V _{p-p}	0.62 V _{p-p}	V _{p-p}	0.98 V _{p-p}		Pass/Fail
Data Out	0.1 V _{p-p}	0.06 V _{p-p}	V _{p-p}	0.14 V _{p-p}		Pass/Fail
	0.8 V _{p-p}	0.62 V _{p-p}	V _{p-p}	0.98 V _{p-p}		Pass/Fail
Waveform						
Connector	Item	Minimum Value	Measured Value	Maximum Value	Measurement Uncertainty	Pass/Fail
Data Out	Crossing	40%	%	60%		Pass/Fail
	Rise Time	/	ps	28 ps		Pass/Fail
	Fall Time	/	ps	28 ps		Pass/Fail
	Jitter (rms)	/	ps	2 ps		Pass/Fail
Data Out	Crossing	40%	%	60%		Pass/Fail
	Rise Time	/	ps	28 ps		Pass/Fail
	Fall Time	/	ps	28 ps		Pass/Fail
	Jitter (rms)	/	ps	2 ps		Pass/Fail

E.2 Error Detector

Table E.2-1 Error Detector Performance Test Record Form (Without Option 092)

Measurement Channel ED 1 2 3 4					
Input Level					
Connector	Set Bit Rate	Minimum Value	ER Measured Value	Maximum Value	Pass/Fail
Data Out	11320000 kbit/s			1E-12	Pass/Fail
	132813 kbit/s			1E-12	Pass/Fail
Data Out	11320000 kbit/s			1E-12	Pass/Fail
	132813 kbit/s			1E-12	Pass/Fail
Rx Sensitivity					
Connector	Set Bit Rate	Minimum Value	ER Measured Value	Maximum Value	Pass/Fail
Data Out	11320000 kbit/s			1E-12	Pass/Fail
Data Out	11320000 kbit/s			1E-12	Pass/Fail
Pattern					
Connector	Pattern	Minimum Value	ER Measured Value	Maximum Value	Pass/Fail
Data Out	PRBS2 ⁷⁻¹			1E-12	Pass/Fail
	PRBS2 ⁹⁻¹			1E-12	Pass/Fail
	PRBS2 ¹⁵⁻¹			1E-12	Pass/Fail
	PRBS2 ²³⁻¹			1E-12	Pass/Fail
	PRBS2 ³¹⁻¹			1E-12	Pass/Fail
Data Out	PRBS2 ⁷⁻¹			1E-12	Pass/Fail
	PRBS2 ⁹⁻¹			1E-12	Pass/Fail
	PRBS2 ¹⁵⁻¹			1E-12	Pass/Fail
	PRBS2 ²³⁻¹			1E-12	Pass/Fail
	PRBS2 ³¹⁻¹			1E-12	Pass/Fail

Table E.2-1 Error Detector Performance Test Record Form (Without Option 092) (Cont'd)

Error Detection					
Connector	Set Bit Rate	Minimum Value	ER Measured Value	EC Measured Value	Pass/Fail
Data Out	11320000 kbit/s	/			Pass/Fail
$\overline{\text{Data Out}}$	11320000 kbit/s	/			Pass/Fail

Table E.2-2 Error Detector Performance Test Record Form (With Option 092)

Measurement Channel ED 1 2 3 4					
Input Level					
Connector	Set Bit Rate	Minimum Value	ER Measured Value	Maximum Value	Pass/Fail
Data Out	12500000 kbit/s			1E-12	Pass/Fail
	125000 kbit/s			1E-12	Pass/Fail
Data Out	12500000 kbit/s			1E-12	Pass/Fail
	125000 kbit/s			1E-12	Pass/Fail
Rx Sensitivity					
Connector	Set Bit Rate	Minimum Value	ER Measured Value	Maximum Value	Pass/Fail
Data Out	12500000 kbit/s			1E-12	Pass/Fail
Data Out	12500000 kbit/s			1E-12	Pass/Fail
Pattern					
Connector	Pattern	Minimum Value	ER Measured Value	Maximum Value	Pass/Fail
Data Out	PRBS2 ⁷⁻¹			1E-12	Pass/Fail
	PRBS2 ⁹⁻¹			1E-12	Pass/Fail
	PRBS2 ¹⁵⁻¹			1E-12	Pass/Fail
	PRBS2 ²³⁻¹			1E-12	Pass/Fail
	PRBS2 ³¹⁻¹			1E-12	Pass/Fail
Data Out	PRBS2 ⁷⁻¹			1E-12	Pass/Fail
	PRBS2 ⁹⁻¹			1E-12	Pass/Fail
	PRBS2 ¹⁵⁻¹			1E-12	Pass/Fail
	PRBS2 ²³⁻¹			1E-12	Pass/Fail
	PRBS2 ³¹⁻¹			1E-12	Pass/Fail

Table E.2-2 Error Detector Performance Test Record Form (With Option 092) (Cont'd)

Error Detection					
Connector	Set Bit Rate	Minimum Value	ER Measured Value	EC Measured Value	Pass/Fail
Data Out	12500000 kbit/s	/			Pass/Fail
$\overline{\text{Data Out}}$	12500000 kbit/s	/			Pass/Fail

E.3 Sampling Oscilloscope

Amplitude Accuracy

Table E.3-1 Level Accuracy

Connector	Setting Voltage	Minimum Value	Measured Value	Maximum Value	Measurement Uncertainty	Pass/Fail
Ch A	+200 mV	+186.5 mV	mV	+213.5 mV		Pass/Fail
	-200 mV	-213.5 mV	mV	-186.5 mV		Pass/Fail
Ch B (Option 021)	+200 mV	+186.5 mV	mV	+213.5 mV		Pass/Fail
	-200 mV	-213.5 mV	mV	-186.5 mV		Pass/Fail

E.4 Optical Interface

Optical Power Meter: ± 0.35 dB or less (-12 dBm or more)

Table E.4-1 Accuracy of Optical Power Meter (Option 023)

Wavelength	Reading of Optical Power Meter	Average Power(dBm) Measurement Value	Minimum Value	Level Difference	Maximum Value	Pass/Fail
850 nm	dBm	dBm	-0.35 dB	dB	+0.35 dB	Pass/Fail
1310 nm	dBm	dBm	-0.35 dB	dB	+0.35 dB	Pass/Fail
1550 nm	dBm	dBm	-0.35 dB	dB	+0.35 dB	Pass/Fail

Appendix F Bibliography

- (1) IEC60825-1 *Safety of laser products. Part 1: Equipment classification, requirements and user's guide*
- (2) IEC61010-1 *Safety requirements for electrical equipment for measurement, control, and laboratory use - Part 1: General requirements*
- (3) IEC61280-2-1 *Fibre optic communication subsystem basic test procedures - Part 2-1: Test procedures for digital systems - Receiver sensitivity and overload measurement*
- (4) IEC61280-2-2 *Fibre optic communication subsystem test procedures - Part 2-2: Digital systems Optical eye pattern, waveform and extinction ratio measurement*
- (5) IEC62150-2 *Fibre optic active components and devices - Test and measurement procedures - Part 2: ATM-PON transceivers*
- (6) IEEE 802.3 *Local and metropolitan area networks— Specific requirements Part 3: Carrier sense multiple access with Collision Detection (CSMA/CD) Access Method and Physical Layer Specifications*
- (7) ISO/IEC 14165-115 *Information technology - Fibre channel - Part 115: Physical interfaces (FC-PI)*
- (8) ITU-T G.651.1 *Characteristics of a 50/125 μm multimode graded index optical fibre cable for the optical access network*
- (9) ITU-T G.652 *Characteristics of a single-mode optical fibre and cable*
- (10) ITU-T G.707 *Network node interface for the synchronous digital hierarchy (SDH)*
- (11) ITU-T G.709 *Interfaces for Optical Transport Network (OTN)*
- (12) ITU-T G.957 *Optical interfaces for equipments and systems relating to the synchronous digital hierarchy*
- (13) ITU-T O.150 *General requirements for instrumentation for performance measurements on digital transmission equipment*
- (14) ITU-T O.151 *Error performance measuring equipment operating at the primary rate and above*
- (15) ANSI INCITS 352-2002 *Information technology - Fibre Channel - Physical Interfaces (FC-PI)*
- (16) *InfiniBand Architecture Release 1.2.1 Volume 2 Physical Specifications*
- (17) SFF Committee INF-8074i *SFP (Small Form-factor Pluggable Transceiver) Revision 1.0*
- (18) SFF Committee INF-8077i *10 Gigabit Small Form Factor Pluggable Module Revision 4.5*
- (19) SFF Committee SFF-8431 *Enhanced Small Form Factor Pluggable Module SFP+ Revision 4.1*

- (20) SFF Committee SFF-8436 *Specification for QSFP+ 10 Gbs 4X PLUGGABLE TRANSCEIVER*
- (21) SFF Committee SFF-8635 *QSFP+ 10 Gb/s 4X Pluggable Transceiver Solution (QSFP10)*
- (22) Common Public Radio Interface *CPRI Specification V6.0*
- (23) Open Base Station Architecture Initiative *Reference Point 3 Specification Version 4.2*
- (24) Anritsu Corporation *Understanding Eye Pattern Measurements*
<http://www.anritsu.com/en-US/Downloads/Application-Notes/Application-Note/DWL7861.aspx>
- (25) Anritsu Corporation *EYE/Pulse Scope User Defined Mask Files*
<http://www.anritsu.com/en-US/Downloads/Product-Introductions/Product-Introduction/DWL8755.aspx>
- (26) Anritsu Corporation *Procedure for Calculating Extinction Ratio Correction Factor*
<http://www.anritsu.com/en-US/Downloads/Manuals/Quick-Reference-Guide/DWL10776.aspx>

References are to page numbers.

Symbol and Numbers

0

0 Level1-13

1

1 Level1-13

1310 nm SFPA-25

1310 nm SFP+A-28

1550 nm SFPA-26

8

850 nm SFPA-24

850 nm SFP+A-27

A

Abbreviation1-23

Accumulation Type7-34

Acquire Clock Rate7-30, 7-32

Add7-69

Adjusting External Attenuator7-46

Adjusting Horizontal-axis Screen7-45

Adjusting mask position7-62

Adjusting Screen Scale7-41

Adjusting the number of bits to display7-45

Adjusting the waveform position7-45

Adjusting time at left side of screen7-45

Adjusting Vertical-axis Screen7-43

Alignment Marker7-62

All Off7-65

Amp/Histogram7-49, 7-54

Amplitude7-43, 7-54

Amplitude and time measurements7-47

Amplitude and Time Measurements7-48

Amplitude dialog box7-8

Amplitude/Time7-49

Amplitude/Time&Mask7-49, 7-57

Angle7-63

Arrow Key Entry Panel4-5

Attenuation7-46

Attenuator Factor6-11

Auto Popup4-12

Auto Scale7-41, 7-42

averaging7-36

Averaging7-36

Averaging process7-36

Axis7-54

B

Basic Procedure of Generating Pulse Signal 5-10

BERTWave Types1-2

Bit Error Rate1-21

Bit Rate1-22

Block4-14

Bottom Mask Failed Samples7-61

Buzzer Off4-12

C

Calibrating attenuation of external

attenuator7-46

Calibrating Sampling Oscilloscope7-24

Calibration10-11

Capture7-71

Cautions against computer virus infection . xviii

Cautions on Handling Optical Fiber Cables 2-16

Cautions on Storage10-14

CE Conformity Markingxix

Center7-54, 7-62, 7-65

Center Mask Failed Samples7-61

Channel and mask7-57

Channel Math7-67

Channel Offset7-67

Cleaning the Ferrule End Surface10-5

Cleaning the Optical Adapter10-6

Cleaning the Optical Fiber Cable Ferrule

End Surface10-7

Clear Reference7-68

Coherent Eye7-67

Collecting Data7-39

Configuring Power Options2-31

Connecting Peripheral Devices2-14

Connecting Power Cord2-13

Connecting Remote Control Devices2-15

Correction Factor7-51

Correspondence between Panel Keys and

KeyboardC-1

Index

Correspondence between Rotary Knob
 Operation and Keyboard..... C-1
Crossed-out Wheeled Bin Symbol xv
CRU Band..... 7-30
CRU loop BW..... 7-30
C-Tick Conformity Markingxxi
Current Mask 7-61

D

Daily Maintenance 10-2
Data Clock Rate..... 7-31
Data Input Method..... 4-5
Default Name/Root..... 4-11
Define Function..... 7-67
Delete..... 7-69
Deleting items 7-52
Deleting overwritten waveform display 7-35
Differential 50 Ohm 6-11
Discarding screen display..... 7-40
Display order 7-52
Display status..... 4-19
Displaying alarm..... 4-12
Displaying Histogram 7-53
Displaying Software Version..... 10-8
Displaying the device internal signal
 connection 4-14
Displaying Time and Status..... 4-19
Displaying Windows Desktop..... 2-27
Disposal 10-15
Duty Cycle Distortion..... 1-19

E

Eco labelxxii
Equipment Certificate..... xii
Ethernet cable 2-14
Exit 4-14
Explanation of Technical Terms..... 1-13
External Attenuation 6-11
Extinction Ratio..... 1-19
Eye Amplitude..... 1-15
EYE Boundary..... 7-49, 7-50
Eye Crossing Percentage..... 1-15
Eye Height..... 1-15
Eye Mask 1-17

Eye Mask Select 7-57
Eye Pattern..... 1-16
Eye Width..... 1-17
Eye/Pulse Scope Fatal Temperature 4-20
EYE/Pulse Scope Screen..... 7-2
Eye/Pulse Scope Temperature..... 4-20

F

Fall Time 1-20
Features..... 1-8
File Compatibility with Previous Product... 5-24
Firmware/FPGA 10-8
Function List 6-2

H

Histogram..... 7-47, 7-54
Histogram Marker..... 7-54
Hits 7-54

I

Infinite..... 7-34
Information..... 10-8
Initial Values of ED..... B-2
Initial Values of O/E Converter..... B-7
Initial Values of Optical Transceiver (SFP+) B-7
Initial Values of PPG..... B-1
Initial Values of PPG/ED..... B-1
Initial Values of Sampling Oscilloscope B-3
Initial Values of Setup Utility B-8
Initialize 4-12
Initializing measurement conditions..... 4-12
Inserting Bit Error 5-25
Inserting bit errors one bit at a time using
 screen operation..... 5-25
Inserting fixed proportion of bit errors..... 5-25
Insertion Error 1-20
Installation 2-3
Intended Use 1-9
Introduction of BERTWave Series 1-2
Inverse background color..... 7-71
Item Selection..... 7-49

J

Jitter 1-18

L

Labels on Product.....	viii
Laser Radiation Markings.....	ix
Laser Safety Classifications	vii
Length	7-38
Lifetime of Parts.....	xiv
Limit Type.....	7-35
Limited	7-34
List of Setting Items.....	5-2
Load.....	10-10
Local/Panel Unlock.....	4-13
Locking the panel operation.....	4-13

M

Manual Notation System	III
Marker.....	7-65
Mask Area Restriction.....	7-63
Mask File Specifications.....	D-4
Mask margin	7-59
Mask Margin	1-22, 7-61
Mask test.....	7-47
Mask Test.....	7-56, 7-57
Mean.....	7-54
Measure Dialog box	7-6
Measurement area.....	7-49
Measurement items.....	7-49
Measurement method.....	6-22
Measurement method of rise/fall time	7-51
Measurement Result	6-24
Measuring Area Display.....	7-49
Minimize.....	4-14
Minimizing the screen display	4-14

N

Negative Logic (NEG).....	5-22
Notes On Export Management.....	xiv
Notice.....	xviii
Number of samples.....	7-35, 7-36
Numeric value entry panel.....	4-6

O

Offset	7-67
Offset from Crossing.....	7-50
OK	7-71

OMA	1-20
Omission Error	1-20
One Level.....	1-13
Open	4-10
Operating O/E Converter	8-7
Operating Optical Transceiver	8-5
Optical Connector/Optical Adapter	
Cleaning	10-5
Optical Interface Types	8-2
Optical Modulation Amplitude.....	1-20
Optical Power Meter.....	9-26
optical transceiver	2-19
Optical Transceiver Module Specifications	A-24
Optional Accessories.....	1-6
Options	1-4

P

Panel Lock	4-13
Pattern Sync.....	6-16
Performance Test Record Form	
Pulse Pattern Generator.....	E-2
Performance Test for Error Detector.....	9-8
Performance Test for Optical Interface	
(O/E Converter).....	9-25
Performance Test for Sampling oscilloscope	9-21
Performance Test Record Form	
Error Detector	E-5
Optical Interface	E-10
Sampling Oscilloscope.....	E-9
Persistency	7-34
Positive Logic (POS)	5-22
Power	4-20
Power Requirements	2-12
Power-off.....	2-24
Power-on.....	2-23
p-P.....	1-13
P-P	7-54
PPG Pattern Sync PPG Pattern Sync.....	5-27
PPG/ED Fatal Temperature.....	4-20
PPG/ED Hardware Error	4-20
PRBS	1-14
Preventing Damage	2-37
Procedure of Measuring Bit Error Rate	6-9
Procedures at System Alarm.....	4-20

Index

Programmable Pattern.....5-21

R

Reading measurement conditions from file..4-10

Rear Panel.....2-10

Reboot.....10-10

Recommended storage conditions.....10-14

Ref.Trace Channel.....7-68

reference trace.....7-68

Repackaging.....10-15

Repeat.....6-21

Replacement of Optical Connector.....10-3

Result Window.....7-3

Rise/Fall Time.....7-51

Rise/Fall Time Correction.....7-51

RMS.....1-14

S

Sample.....7-35

Sampling Oscilloscope.....1-18

Save.....4-9

Saving a screen to the image file.....4-11

Saving measurement conditions and
measurement results.....4-9

Saving Measurement Result.....7-70

Scale.....7-67

Screen Configuration.....4-2

Screen Copy.....4-11

Selector Screen.....2-23

self test.....7-26

Set Reference.....7-68

Setting Bit Rate.....7-31

Setting buzzer.....4-12

Setting Clock Rate and Divide Rate.....7-32

Setting Clock Recovery Unit.....7-29

Setting Control Panel.....2-27, 2-28

Setting Interface for Remote Control.....2-32

Setting Item List.....7-12

Setting Measurement Conditions.....6-21

Setting Output Waveform.....5-16

Setting overwritten waveform display.....7-34

Setting Pattern Length.....7-38

Setting Patterns.....5-20

Setting Reference Clock.....5-11

Setting Restrictions.....5-9

Setting same vertical scale for two
waveforms.....7-44

Setting Sync Output.....5-26

Setting System Menu.....4-8

Setup Dialog Box.....7-4

Side Panel.....2-11

Single.....6-21

Single-End Data.....6-11

Single-End XData.....6-11

SNR.....1-15

Software.....10-8

Software Keyboard.....4-7

Specifications for Data Pattern File.....D-2

Starting data collection.....7-39

std Dev.....7-54

Stopping data collection.....7-39

Sync Loss.....6-23

Sync Threshold.....6-16

System Alarm.....4-12

system alarm factor.....4-20

System Menu.....4-8

System Recovery.....2-43

T

Target Failed Samples.....7-61

Technical Terms.....1-13

Terminating applications.....4-14

Threshold Level.....6-11

Time.....7-35, 7-45, 7-54

Time Dialog Box.....7-10

To adjust center power voltage or optical
power at vertical axis.....7-43

To display date and time.....4-19

To limit mask area.....7-63

To set Mask Margin and execute mask test 7-60

To switch to Eye/Pulse/Coherent mode.....7-33

Top Mask Failed Samples.....7-61

Total Error.....1-20

Total Failed Samples.....7-61

Total Samples.....7-61

Total Waveforms.....7-61

Touch Panel.....10-11

Touch Panel Position Correction.....10-11

Tracking Off7-38
Transporting.....10-15
Transporting and Destroy10-15
Turning Power On/Off.....2-23

U

Unlocking the panel4-13
Unpacking 2-2
Untimed.....6-21
Update7-62, 10-10
Updating Software10-10
User defined7-57
Using External Monitor2-29
Using Marker7-65
Using Trace Memory7-68
Utilities.....7-68, 7-69

W

Waveform7-35
Waveforms only7-71
Width.....7-50, 7-63

Z

Zero Level.....1-13

