



# Signal Analyzer MS2830A

26.5 GHz Signal Analyzer MS2830A-044

43 GHz Signal Analyzer MS2830A-045

Refer to the dedicated product introduction materials for the 3.6 GHz Signal Analyzer MS2830A-040, 6 GHz Signal Analyzer MS2830A-041 and 13.5 GHz Signal Analyzer MS2830A-043



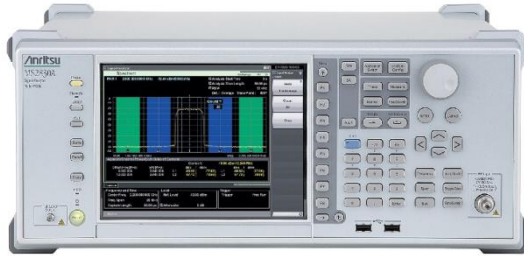

MS2830A-044: 9 kHz to 26.5 GHz  
MS2830A-045: 9 kHz to 43 GHz

## Performance

### ◆ Wide Dynamic Range: 159 dB (@26.5 GHz)

TOI: +13 dBm<sup>\*1</sup> (6 GHz < f ≤ 26.5 GHz)

DANL: -146 dBm/Hz<sup>\*2</sup> (18.3 < f ≤ 34 GHz)

*Dynamic range: Difference between TOI and DANL as simple guide.*

*DANL: Displayed Average Noise Level*

*TOI: Third Order Intercept*

### ◆ Preamp up to 43 GHz

DANL: -156 dBm/Hz<sup>\*3</sup> (18.3 < f ≤ 34 GHz)

### ◆ Excellent Total Level Accuracy

±0.5 dB<sup>\*1</sup> (300 kHz ≤ f < 4 GHz)

±3.0 dB<sup>\*1</sup> (13.8 GHz < f ≤ 40 GHz)

## Functions

<Modulation Analysis>

<Signal Analysis>

### ◆ 125 MHz Analysis Bandwidth up to 43 GHz

Vector Modulation Analysis Software

### ◆ Full Line of Built-in Measurement Functions

## Low Running Costs

### ◆ Cost-Saving Low Power Consumption

190 VA (nominal, MS2830A-044/045 only<sup>\*4</sup>)

\*1: Without MS2830A-068 or Preamp OFF:

\*2: Without MS2830A-067/068

\*3: Without MS2830A-067 or Preselector Bypass OFF, and with MS2830A-068 and Preamp ON

\*4: Excluding other options

## Wide C/N measurement for Spurious, Mask and Occupied Bandwidth tests

MS2830A-045 (43 GHz) TOI-DANL  
with preamplifier, without preselector bypass

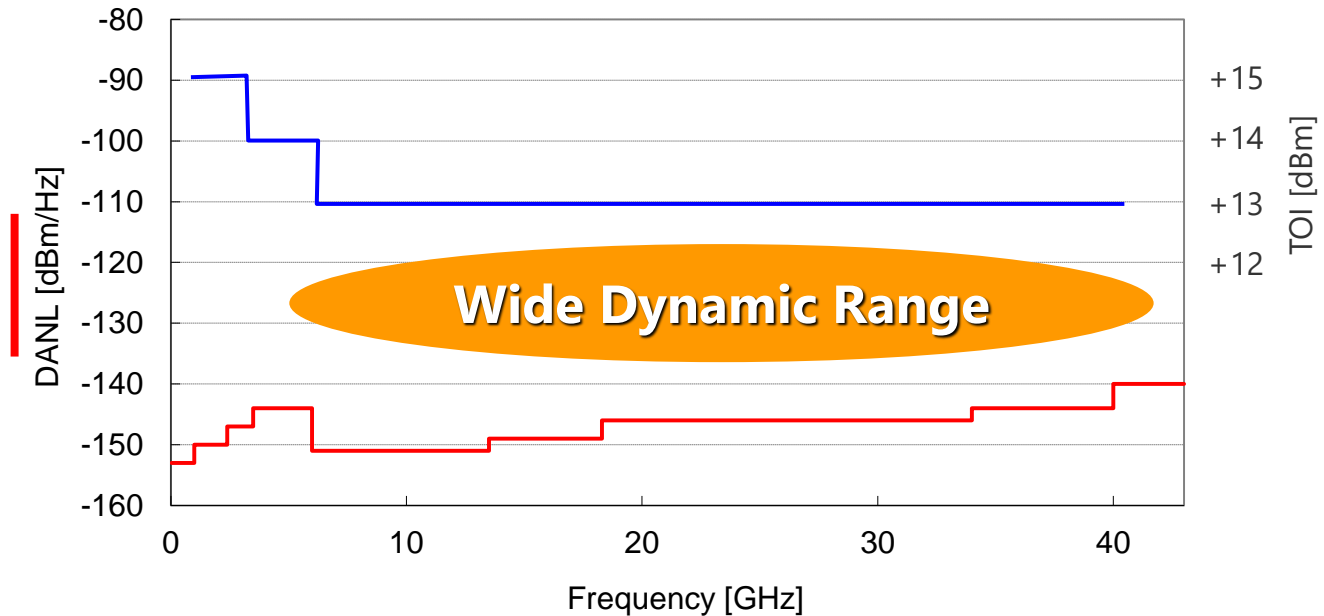

Dynamic range is a key specification for spectrum analyzers. Low displayed average noise level (DANL) as well as third-order intermodulation distortion (TOI) are important too. Sometimes, distortion may occur in the mixer when inputting a carrier signal with low TOI and high level. In this case, the input level to the mixer can be reduced using an attenuator but, at the same time, the level of fine spurious also drops, making it impossible to find the noise floor. The MS2830xA has an excellent dynamic range, supporting accurate measurements for checking the spectrum, such as spurious tests, mask and occupied bandwidth with wide dynamic range.

# Performance: Wide Dynamic Range (2/2)

Excellent performance with >6 GHz ! For spurious tests !

**DANL comparison**  
without Preamplifier and Preselector Bypass

26.5 GHz model  
price image

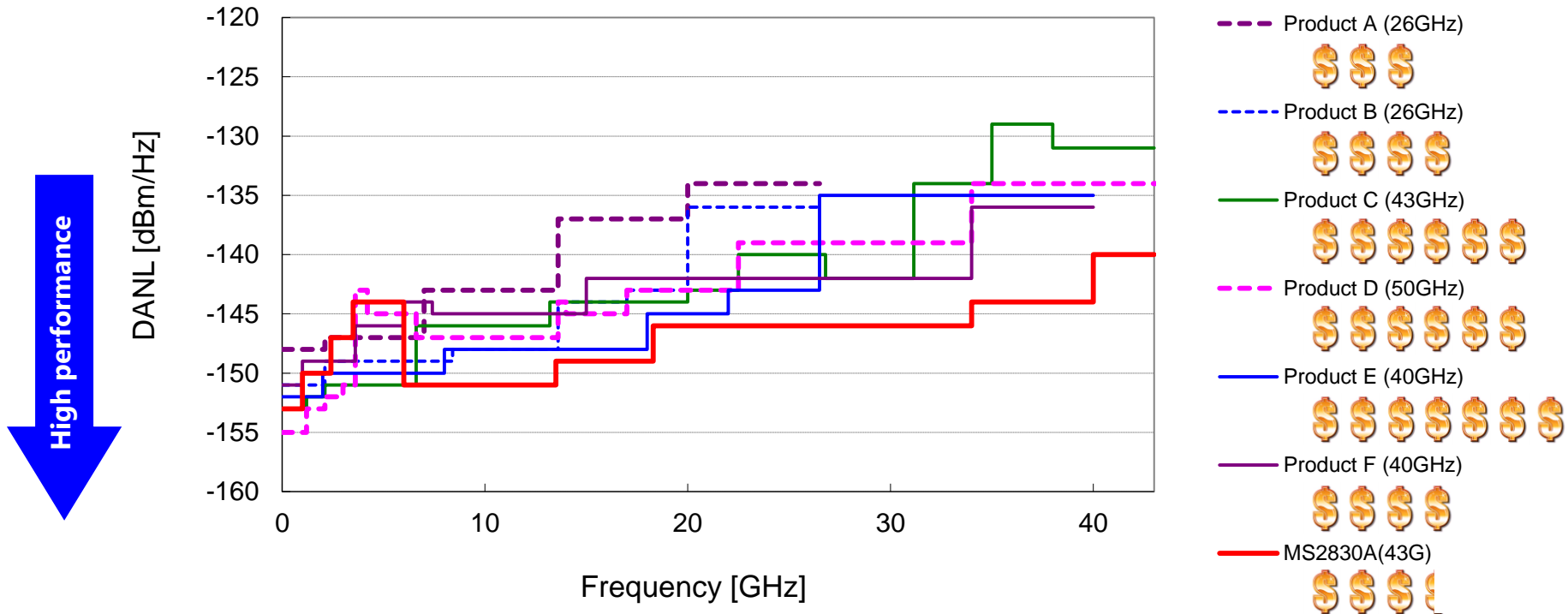

The basic configuration for DANL with >6 GHz supports best-of-class performance. The above performance is assured without preamp option.

# Performance: Preamp Up to 43 GHz (1/2)

Built-in preamp option expands DANL for 10 dB

MS2830A 43 GHz version DANL change by pre-amp

Opt.068 w/preamp, Opt.067 w/o pre-selector bypass

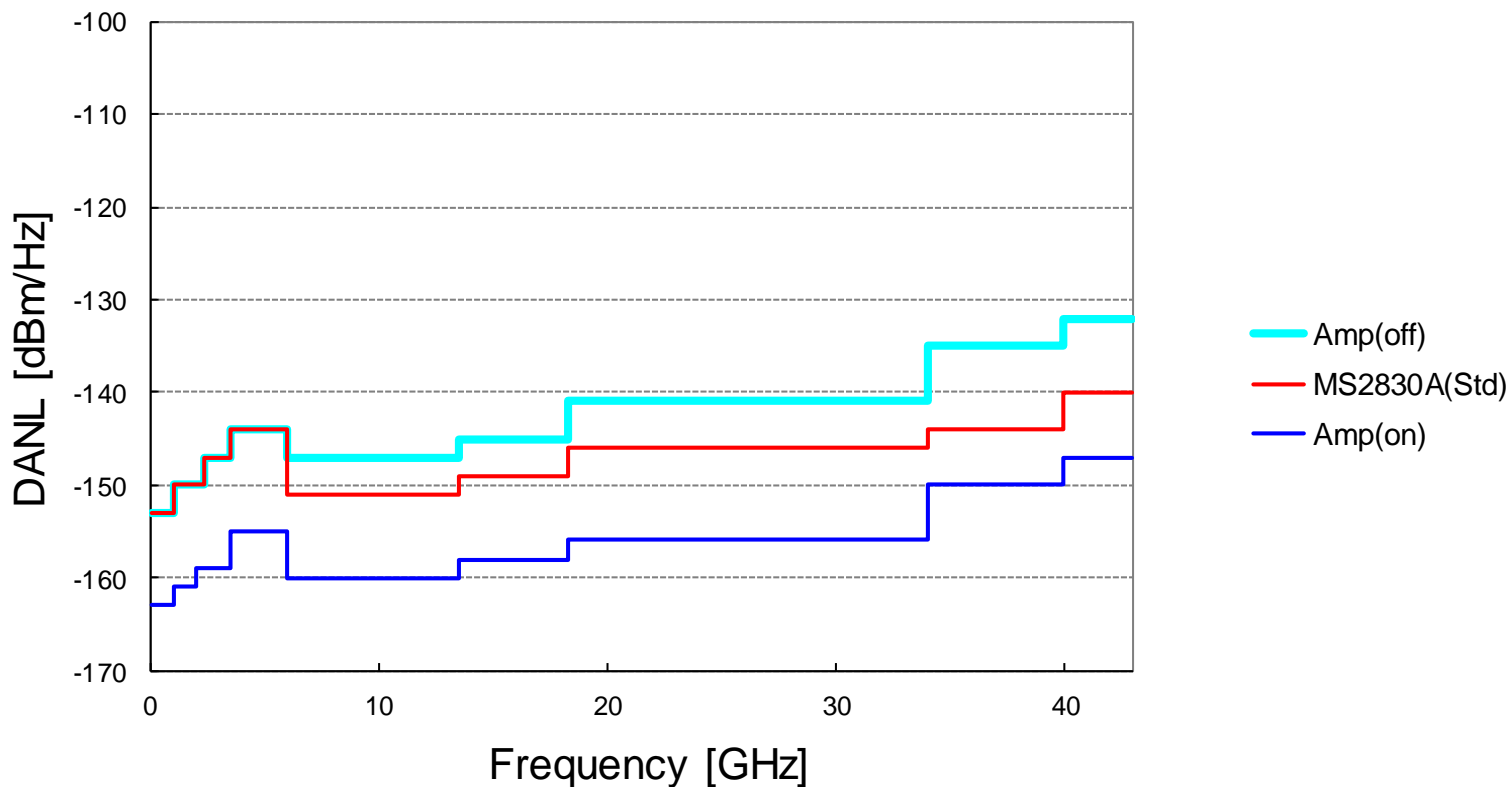

A built-in preamp option supports measurement of weak signals.

## Displayed Average Noise Level (Spectrum Analyzer function)

MS2830A-044 MS2830A-045	-147 dBm/Hz (nominal, 100 kHz) -156 dBm/Hz (1 MHz) -163 dBm/Hz ( $30 \text{ MHz} \leq f < 1 \text{ GHz}$ ) -161 dBm/Hz ( $1 \text{ GHz} \leq f < 2 \text{ GHz}$ ) -159 dBm/Hz ( $2 \text{ GHz} \leq f \leq 3.5 \text{ GHz}$ ) -155 dBm/Hz ( $3.5 \text{ GHz} < f \leq 4 \text{ GHz}$ ) -155 dBm/Hz ( $4 \text{ GHz} < f \leq 6 \text{ GHz}$ ) -160 dBm/Hz ( $6 \text{ GHz} < f \leq 13.5 \text{ GHz}$ ) -158 dBm/Hz ( $13.5 \text{ GHz} < f \leq 18.3 \text{ GHz}$ ) -156 dBm/Hz ( $18.3 \text{ GHz} < f \leq 26.5 \text{ GHz}$ )
MS2830A-045	-156 dBm/Hz ( $26.5 \text{ GHz} < f \leq 34 \text{ GHz}$ ) -150 dBm/Hz ( $34 \text{ GHz} < f \leq 40 \text{ GHz}$ ) -147 dBm/Hz ( $40 \text{ GHz} < f \leq 43 \text{ GHz}$ )

without MS2830A-067 Microwave Preselector Bypass, or Microwave Preselector Bypass: Off  
with MS2830A-068 Microwave Preamplifier, Preamplifier: On, Frequency band mode: Normal

## Reliable catalog specification

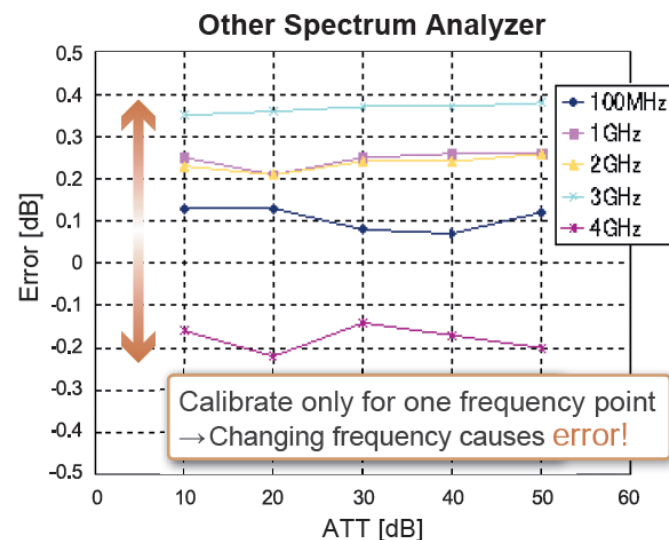
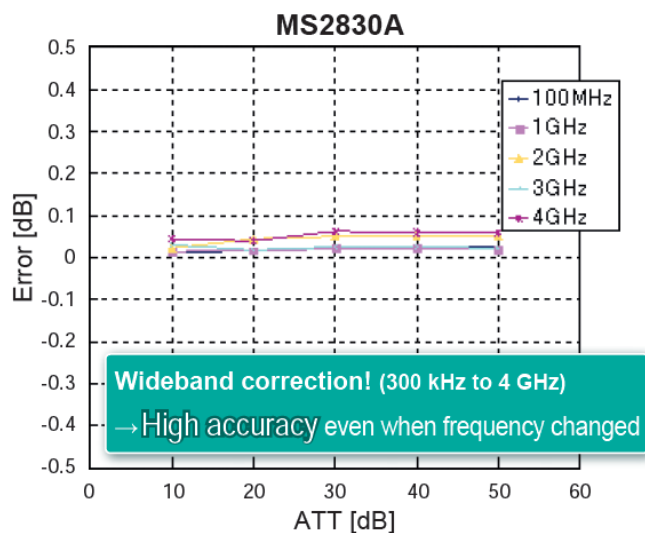

The MS2830A total level accuracy includes:

- Frequency characteristics
- Linearity
- Attenuator switching error

The absolute amplitude accuracy specifications of other spectrum analyzers excludes:

- Frequency characteristics
- Linearity
- Attenuator switching error

Most spectrum analyser catalog specifications do not include attenuator switching error in the absolute level accuracy, frequency characteristics, and linearity values.

However, the total level of accuracy of the MA2830A in the catalog includes the above three errors. Stable measurement is assured in the prescribed error range even when changing the frequency/attenuator.

# Performance: MS2830A Series Comparison Chart (1/2)

## MS2830A-044/045

Frequency option	MS2830A-040*1	MS2830A-041*1	MS2830A-043*1	MS2830A-044	MS2830A-045
Frequency range	9 kHz to 3.6 GHz	9 kHz to 6 GHz	9 kHz to 13.5 GHz	9 kHz to 26.5 GHz	9 kHz to 43 GHz
Aging rate	$\pm 1 \times 10^{-7}$ /day (Standard) $\pm 1 \times 10^{-8}$ /day (Opt. 002) $\pm 1 \times 10^{-10}$ /month (Opt. 001)			$\pm 1 \times 10^{-8}$ /day (Standard) $\pm 1 \times 10^{-10}$ /month (Opt. 001)	
Start time/Characteristics	5 minutes, $\pm 5 \times 10^{-7}$ (Standard) 5 minutes, $\pm 5 \times 10^{-8}$ (Opt. 002) 7 minutes, $\pm 1 \times 10^{-9}$ (Opt. 001)			5 minutes, $\pm 5 \times 10^{-8}$ (Standard) 7 minutes, $\pm 1 \times 10^{-9}$ (Opt. 001)	
Phase noise	Frequency: 500 MHz, Spectrum Analyzer mode				
1 kHz offset	-109 dBc/Hz (Opt. 066)			—	
10 kHz offset	-118 dBc/Hz (Opt. 066)			—	
100 kHz offset	-115 dBc/Hz (Standard) -133 dBc/Hz (Opt. 066)			-115 dBc/Hz (Standard)	
1 MHz offset	-133 dBc/Hz (Standard) -148 dBc/Hz (Opt. 066), nominal			-133 dBc/Hz (Standard)	
Displayed average noise level (DANL)	Spectrum Analyzer mode without options				
Frequency: 500 MHz				-153 dBm/Hz	
Frequency: 2 GHz	-151 dBm/Hz			-150 dBm/Hz	
Frequency: 5 GHz	-146 dBm/Hz			-144 dBm/Hz	
Frequency: 12 GHz	-142 dBm/Hz			-151 dBm/Hz	
Frequency: 25 GHz				-146 dBm/Hz	
Frequency: 40 GHz				-144 dBm/Hz	
Attenuator range/step	0 to 60 dB/2 dB step				0 to 60 dB/10 dB step



# Performance: MS2830A Series Comparison Chart (2/2)

## MS2830A-044/045

Frequency option	MS2830A-040*1	MS2830A-041*1	MS2830A-043*1	MS2830A-044	MS2830A-045
Frequency range	9 kHz to 3.6 GHz	9 kHz to 6 GHz	9 kHz to 13.5 GHz	9 kHz to 26.5 GHz	9 kHz to 43 GHz
Total absolute amplitude accuracy	Unlike normal Total Level Accuracy, this includes frequency characteristics, attenuator switching error and linearity error. Since it gives an instinctive impression of measurement instrument error, it lowers the risk of measurement errors.				
Frequency :500 MHz, 2 GHz	±0.5 dB				
Frequency: 5 GHz, 12 GHz	±1.8 dB				
Frequency: 25 GHz				±3.0 dB	
Frequency: 40 GHz					±3.0 dB
Resolution bandwidth	1 Hz to 3 MHz (1-3 sequence), 5, 10, 20*8, 31.25 MHz*8, 50 kHz [Spectrum Analyzer mode]				
Analysis bandwidth	10 MHz (Opt. 006) 31.25 MHz (Opt. 005) 62.5 MHz (Opt. 077)*9 125 MHz (Opt. 078)*9			10 MHz (Opt. 006) 31.25 MHz (Opt. 009) 62.5 MHz (Opt. 077)*9 125 MHz (Opt. 078)*9	
Additional functions					
Vector signal generator	✓ (Opt. 020/021)			—	
Low phase noise performance*2	✓ (Opt. 066)			—	
Phase noise measurement function	✓ (Opt. 010)				
Noise figure measurement function	✓ (Opt. 017)				
BER measurement function	✓ (Opt. 026)				
Preamplifier*3	✓ (Opt. 008)				
Microwave preamplifier*4	—			✓ (Opt. 068)	
Microwave preselector bypass*5	—			✓ (Opt. 067)	
External mixer 1st local signal output*6	—			✓ (Standard)	
1st IF signal output*7	—			✓ (Standard)	

\*1: See catalog for MS2830A-040/041/043.

\*2: Phase noise improved for <3.6 GHz.

\*3: Frequency range: 100 kHz to 3.6 GHz (MS2830A-040)  
100 kHz to 6 GHz (excluding MS2830A-040)

\*4: Frequency range: 100 kHz to 26.5 GHz (MS2830A-044),  
100 kHz to 43 GHz (MS2830A-045)

\*5: Frequency range: 4 GHz to 26.5 GHz (MS2830A-044),  
4 GHz to 43 GHz (MS2830A-045)

\*6: Connector: SMA-J, 50Ω, Local signal: 5 GHz to 10 GHz

\*7: Connector: SMA-J, 50Ω, Frequency: 1875 MHz

\*8: Can be set when with MS2830A-005. Can not be set when with MS2830A-009.

\*9: Signal Analyzer Mode Frequency Setting Range

With Opt. 077/078, With Opt. 067, >31.25 MHz bandwidth

300 MHz to 26.5 GHz [MS2830A-044]

300 MHz to 43 GHz [MS2830A-045]

With Opt. 077/078, Without Opt. 067, >31.25 MHz bandwidth

300 MHz to 3.6 GHz [MS2830A-040]

300 MHz to 6 GHz [MS2830A-041]

300 MHz to 13.5 GHz [MS2830A-043]

300 MHz to 6 GHz [MS2830A-044]

300 MHz to 6 GHz [MS2830A-045]

# MS2830A-067 Microwave Preselector Bypass supports 125 MHz wideband measurements up to 43 GHz

## MX269017A Vector Modulation Analysis Software

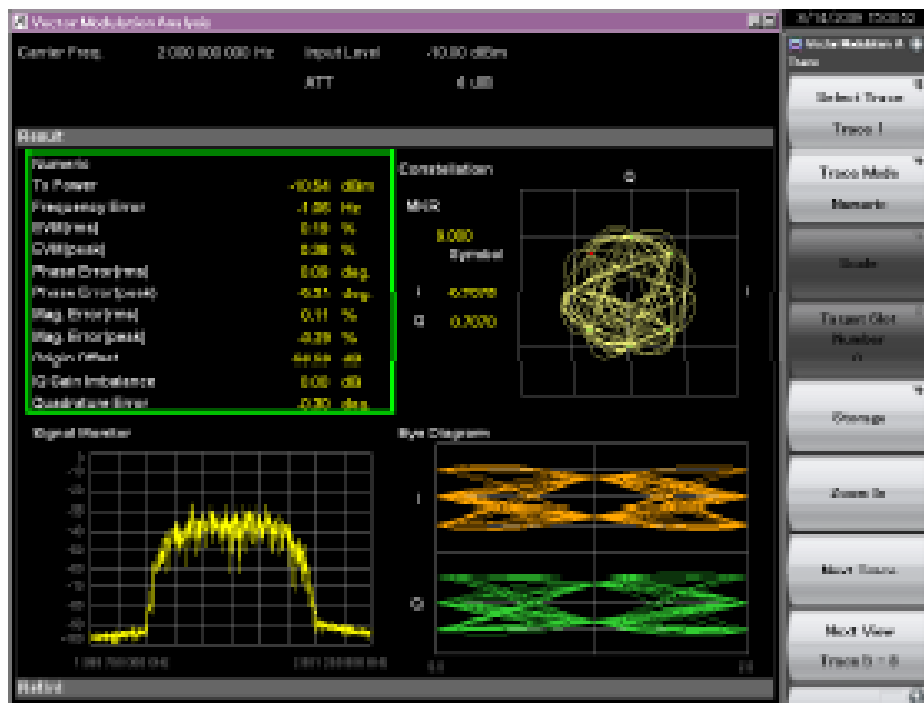

- Modulation method  
 BPSK, QPSK, O-QPSK, Pai/4 DQPSK, 8PSK, 16QAM, 64QAM, 2FSK, 4FSK, 256QAM \*1
- Filter (Depends on Modulation method)  
 Root Nyquist, Nyquist, Gaussian, ARIB STD-T98, Half-sine, Inverse Rect, Inverse Gaussian, None, User Defined
- Symbol rate  
 (Upper limit depends on analysis bandwidth)  
 0.1 k to 1.25/3.125/6.25/12.5 Msymbol/s\*2  
 0.1 k to 2.5/6.25/12.5/25 Msymbol/s\*3  
 0.1 k to 5/12.5/25/50 Msymbol/s\*4  
 0.1 k to 5/35/70/140 Msymbol/s\*5

\*1: 256QAM available with Non-Format  
 \*2: When O-QPSK  
 \*3: When 2FSK and 4FSK  
 \*4: When Frame Formatted and xxPSK, xxQAM  
 \*5: When Non-Formatted and xxPSK, xxQAM

Wideband analysis with high frequencies is supported for microwave links.  
 Modulation analysis and various VSA functions improve design verification efficiency.

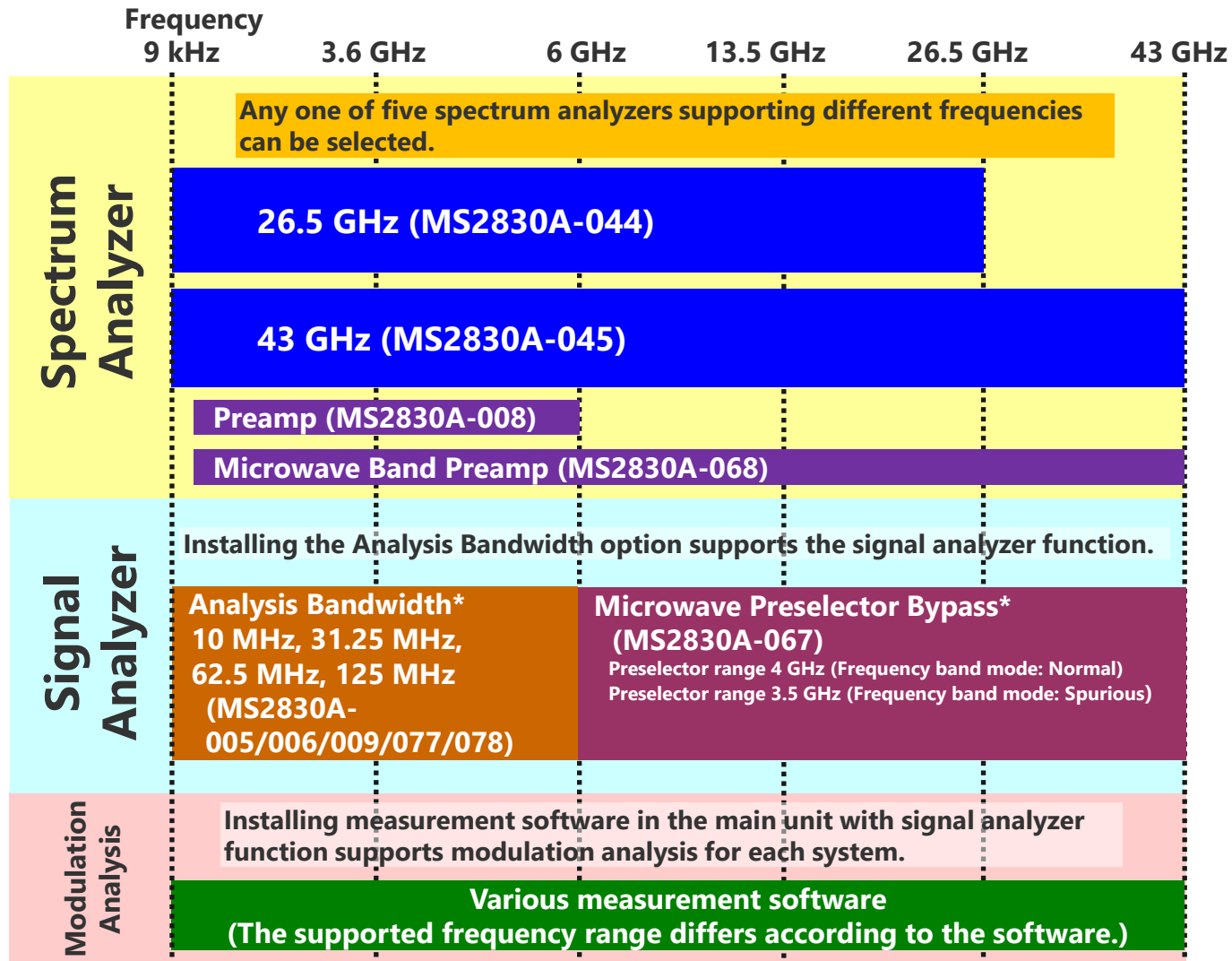

\*: The next slide shows the required Analysis Bandwidth and Microwave Preselector Bypass options.

Model/Name	MS2830A-006 Analysis Bandwidth 10 MHz MS2830A-106 Analysis Bandwidth 10 MHz Retrofit
Purpose	Adds 10 MHz bandwidth analysis function

Model/Name	MS2830A-005 Analysis Bandwidth 31.25 MHz MS2830A-105 Analysis Bandwidth 31.25 MHz Retrofit
Purpose	Adds 31.25 MHz bandwidth analysis function
Installation	Requires MS2830A-006/106 Cannot be installed in MS2830A-045

Model/Name	MS2830A-009 Analysis Bandwidth 31.25 MHz for Millimeter-wave MS2830A-109 Analysis Bandwidth 31.25 MHz for Millimeter-wave Retrofit
Purpose	Adds 31.25 MHz bandwidth analysis function
Installation	Requires MS2830A-006/106 Dedicated option for MS2830A-045 Cannot be set the RBW to more than 10MHz in spectrum analyzer function.

Model/Name	MS2830A-077 Analysis Bandwidth 62.5 MHz
Purpose	Adds 62.5 MHz bandwidth analysis function
Installation	Retrofit not supported Requires MS2830A-006, 005/009

Model/Name	MS2830A-078 Analysis Bandwidth 125 MHz
Purpose	Adds 125 MHz bandwidth analysis function
Installation	Retrofit not supported Requires MS2830A-006, 005/009, 077

Note) MS2830A-077/078:

An image response is received when setting the bandwidth to more than 31.25 MHz. This can be used when not inputting a signal frequency outside the MS2830A analysis bandwidth (125 MHz max.). The Signal Analyzer MS2690A is recommended for other measurement purposes.

Model/Name	MS2830A-067 Microwave Preselector Bypass MS2830A-167 Microwave Preselector Bypass Retrofit
Purpose	Bypass preselector to improve RF frequency characteristics and in-band frequency characteristics
Frequency range	4 to 26.5 GHz (MS2830A-044) 4 to 43 GHz (MS2830A-045)
Installation	MS2830A-044/045 can be installed. Add MS2830A-067 when using the signal analyzer measurement functions at bandwidth: > 31.25 MHz and frequency: > 6 GHz.

## Require options by the combination of preselector bypass and analysis bandwidth

	Preselector Bypass	Analysis Bandwidth	Require Options					
			005	006	009	077	078	067
MS2830A-044	With	10 MHz		✓				✓
		31.25 MHz	✓	✓				✓
		62.5 MHz	✓	✓		✓		✓
		125 MHz	✓	✓		✓	✓	✓
9 kHz to 26.5 GHz	Without	10 MHz		✓				
		31.25 MHz	✓	✓				
		62.5 MHz	✓	✓		✓		
		125 MHz	✓	✓		✓	✓	
MS2830A-045	With	10 MHz		✓				✓
		31.25 MHz		✓	✓			✓
		62.5 MHz		✓	✓	✓		✓
		125 MHz		✓	✓	✓	✓	✓
9 kHz to 43 GHz	Without	10 MHz		✓				
		31.25 MHz		✓	✓			
		62.5 MHz		✓	✓	✓		
		125 MHz		✓	✓	✓	✓	

## Supports simple operation measurement functions

Measure Function	SPA <sup>*1</sup>	VSA <sup>*2</sup>
Channel Power	✓	✓
Occupied Bandwidth	✓	✓
Adjacent Channel Leakage Power	✓	✓
Spectrum Emission Mask	✓	✓
Burst Average Power	✓	✓
Spurious Emission	✓	✓
AM Depth		✓
FM Deviation		✓
Multi-marker & Marker List	✓	✓
Highest 10 Markers	✓	✓
Limit Line	✓	
Frequency Counter	✓	
2-tone 3rd-order Intermodulation Distortion	✓	
Annotation Display (On/Off)	✓	
Power Meter	Independent function <sup>*3</sup>	
Phase Noise	MS2830A-010	
Noise Figure	MS2830A-017 <sup>*4</sup>	

\*1: SPA (Spectrum Analyzer)

\*2: VSA (Vector Signal Analyzer), Requires MS2830A-005/006/077/078

\*3: Use USB Power Sensors

\*4: Use Noise Sources (Noisecom, NC346 series)

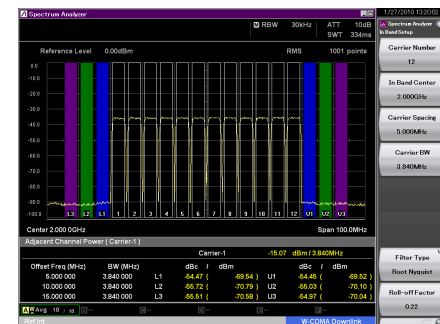

Adjacent Channel Leakage Power

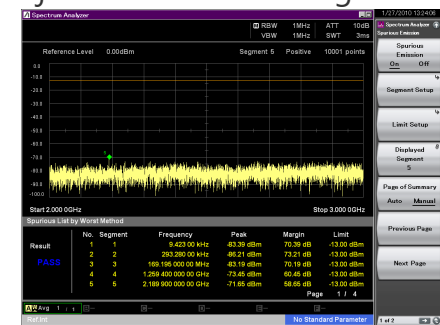

Spurious Emission

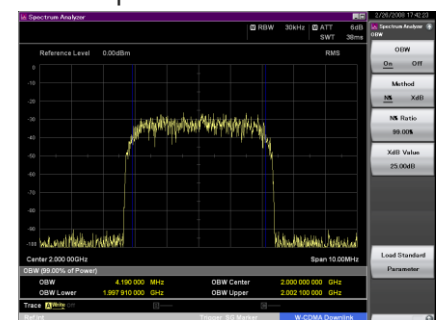

Occupied Bandwidth

## Signal Analyzer (VSA) Display Mode

### Frequency vs. Time

Measures FSK and GMSK modulation wave frequency variation, and VCO frequency switching time

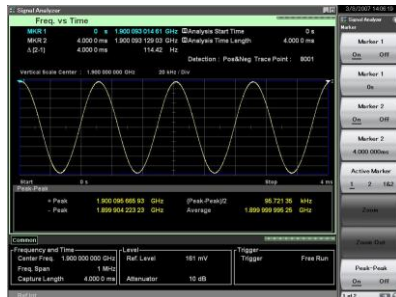

### Phase vs. Time

Monitors time fluctuations of phase to check sudden phase shift

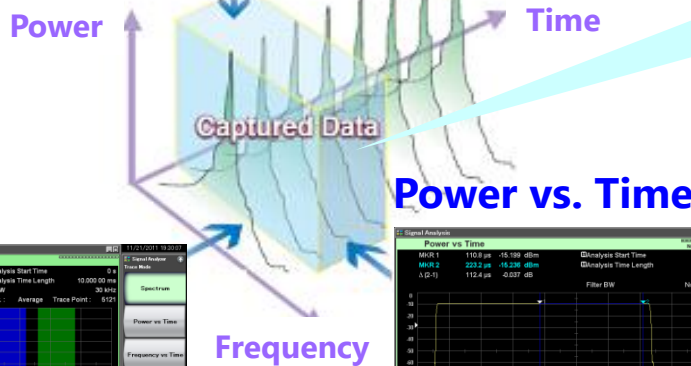
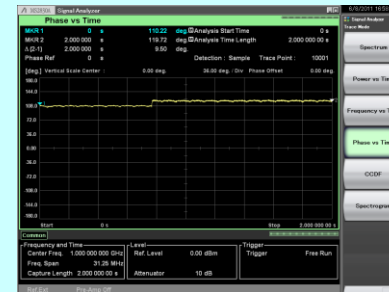

### Spectrum



Displays waveform of wideband SPAN up to 125 MHz without interruption

### Power vs. Time

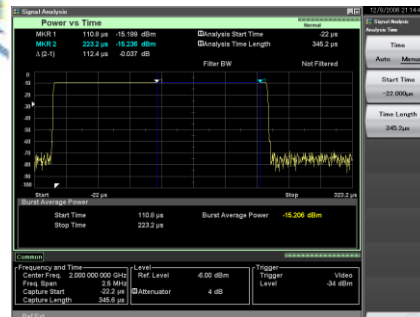

Supports wideband CCDF analysis up to 31.25 MHz; useful for evaluating power amplifiers in wideband communications systems

### Spectrogram

Displays spectrum variations with time; useful for understanding waveform transients because supports visual monitoring of frequency and level time variations



### CCDF/APD

Supports wideband CCDF analysis up to 125 MHz and ideal for evaluating power amps for wideband communication systems

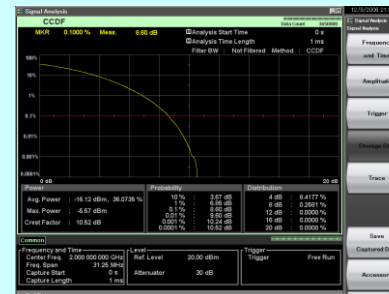

## Excellent Eco Product

### Eco-friendly products

After a global assessment, the Anritsu group has been recognized as manufacturing eco-friendly products.

Excellent eco product: Products receiving score or 80 or more

Eco product: Products receiving score or 60 or more

Assessed product: Product meeting assessment conditions



**Reduce raw materials/production costs**  
**Reduce toxic materials**  
**Reduce distribution costs**  
**Reduce usage costs**  
**Reduce waste at disposal**

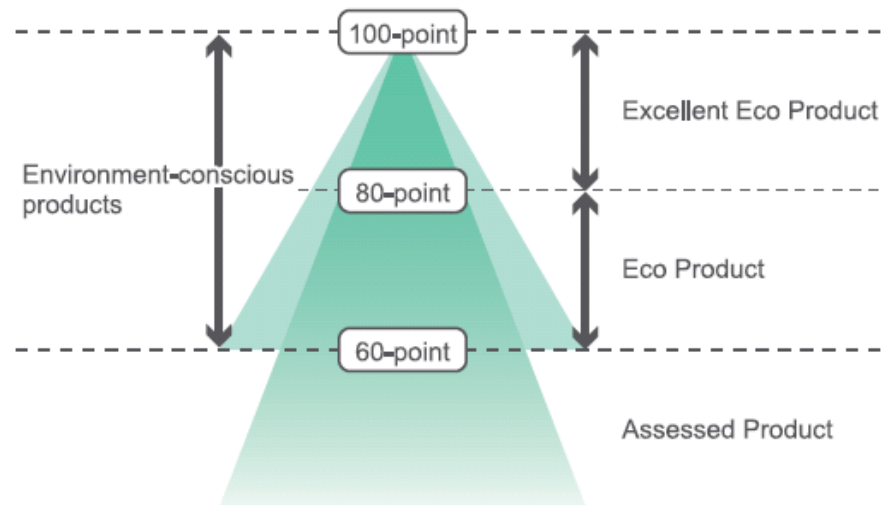

## Low Power Consumption

Anritsu conventional model

Spectrum Analyzer



**≤400 VA**

**210 VA down**  
**52.5% cut**



MS2830A-044/045



**Specification: ≤190 VA\*\* nominal**

**Measurement example: ≤170 VA\***

\*: With MS2830A-044/045 and excluding other options

\*\* : With full options; example only and not guaranteed

Most faults during the stabilization period are due to heat-deteriorated parts. Restricted airflow causing overheating causes parts deterioration and increases fault rates.

Lower power consumption reduces heat production, helping cut both fault rates and running costs.



# Useful Measurement Functions for Evaluating Tx Characteristics (1/21)

The MS2830A has all the versatile built-in measurement functions needed for evaluating Tx characteristics. Using functions matching measurements supports simple tests according to specifications.

Measure Function	SPA <sup>*1</sup>	VSA <sup>*2</sup>
Channel Power	✓	✓
Occupied Bandwidth	✓	✓
Adjacent Channel Leakage Power	✓	✓
Spectrum Emission Mask	✓	
Burst Average Power	✓	✓
Spurious Emission	✓	
AM Depth		✓
FM Deviation		✓
Multi-marker & Marker List	✓	✓
Highest 10 Markers	✓	✓
Limit Line	✓	
Frequency Counter	✓	
2-tone 3rd-order Intermodulation Distortion	✓	
Annotation Display (On/Off)	✓	
Power Meter	Independent function <sup>*3</sup>	
Phase Noise	MS2830A-010	
Noise Figure	MS2830A-017 <sup>*4</sup>	

\*1: SPA (Spectrum Analyzer)

\*2: VSA (Vector Signal Analyzer), Requires MS2830A-005/006/077/078

\*3: Use USB Power Sensors

\*4: Use Noise Sources (Noisecom, NC346 series)

## Channel Power

Channel power measurement using three types of filter (Rectangular, Nyquist, Root Nyquist) is supported.

### Channel Power Measurement

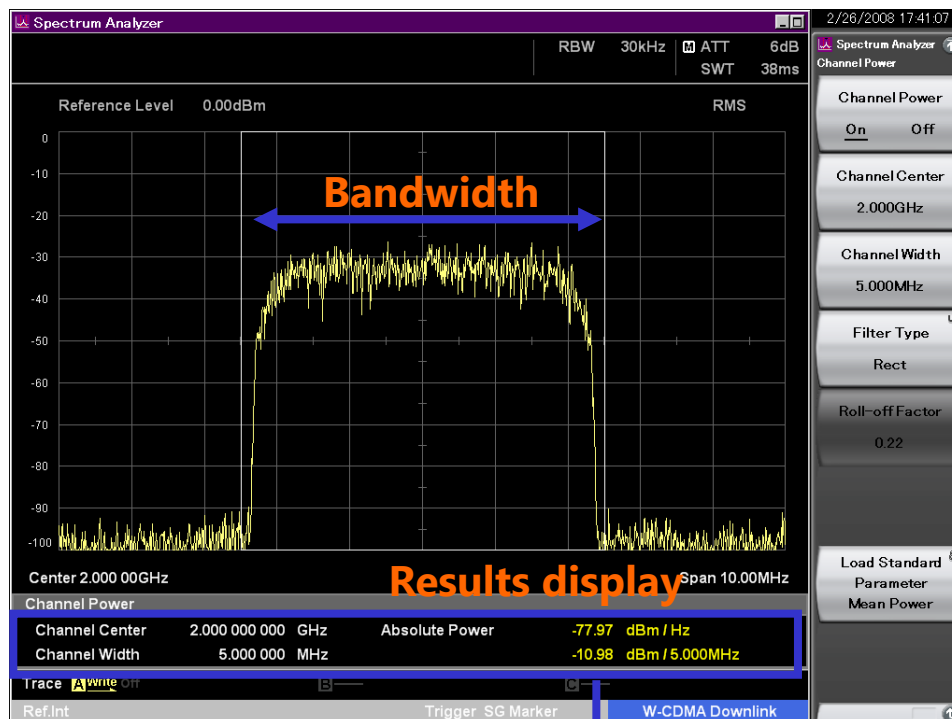

Measurement function ON/OFF

Channel center frequency

Channel bandwidth

**Filter:**

Rectangular, Nyquist, Root Nyquist

Channel Center: Set value for channel center frequency

Channel Width: Set value for channel bandwidth

Absolute Power: Power per Hz (Density)

In-zone power (Integration)

## Occupied Bandwidth

Occupied bandwidth is measured in two modes—N% and X dB.

### Occupied Bandwidth Measurement

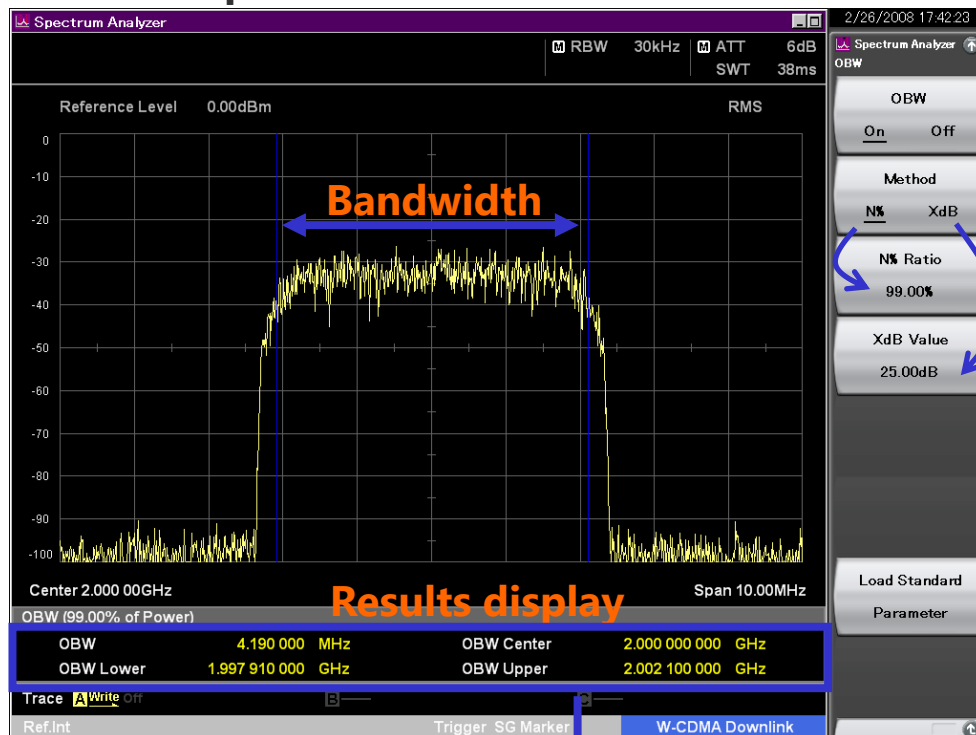

Measurement function ON/OFF

Measurement mode selection: (See below)

% setting for <N%> mode

Power setting for <X dB> mode

**N% mode:**  
Bandwidth containing N% power with total power in display as 100%

**X dB mode:**  
Bandwidth X dB down from peak value

OBW: Occupied bandwidth

OBW Center: Center frequency of occupied bandwidth

OBW Lower: Occupied bandwidth left-side frequency

OBW Upper: Occupied bandwidth right-side frequency

## Adjacent Channel Leakage Power (ACLR)

This function measures adjacent channel leakage power.

### Adjacent Channel Leakage Power Measurement

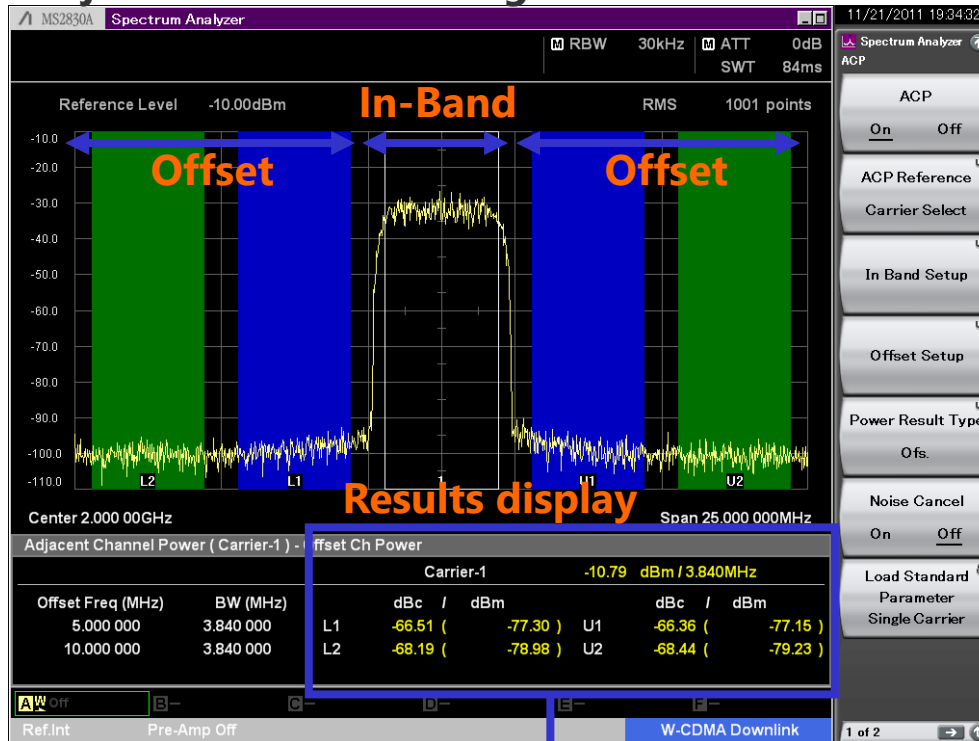

Measurement function ON/OFF

Reference Power setting: (See below)

In-band setting

Offset Channel setting

Result display switching

Carrier: In-band, Ofs: Offset Channel,

All: Both In-band and Offset Channel

Noise cancellation function ON/OFF

(subtracts main-frame noise from measurement result)

Relative power for Offset 1 to 3 [dBc] vs. reference power selected with ACP Reference  
( ) indicates absolute power [dBm].

#### Reference power setting:

- SPAN TOTAL: Integral power for overall display
- Carrier Total: Total of all carrier power
- Both Sides of Carriers: Out-of-band carrier power
- Carrier Select: Specified carrier power

## Adjacent Channel Leakage Power (ACLR)

In Band can be set from 1 to 12 carriers and switched instantaneously on the screen. Moreover, true ACLR performance is measured using the noise cancellation function to subtract main-frame noise from the measurement result.

### ACLR Measurement (12 carriers)

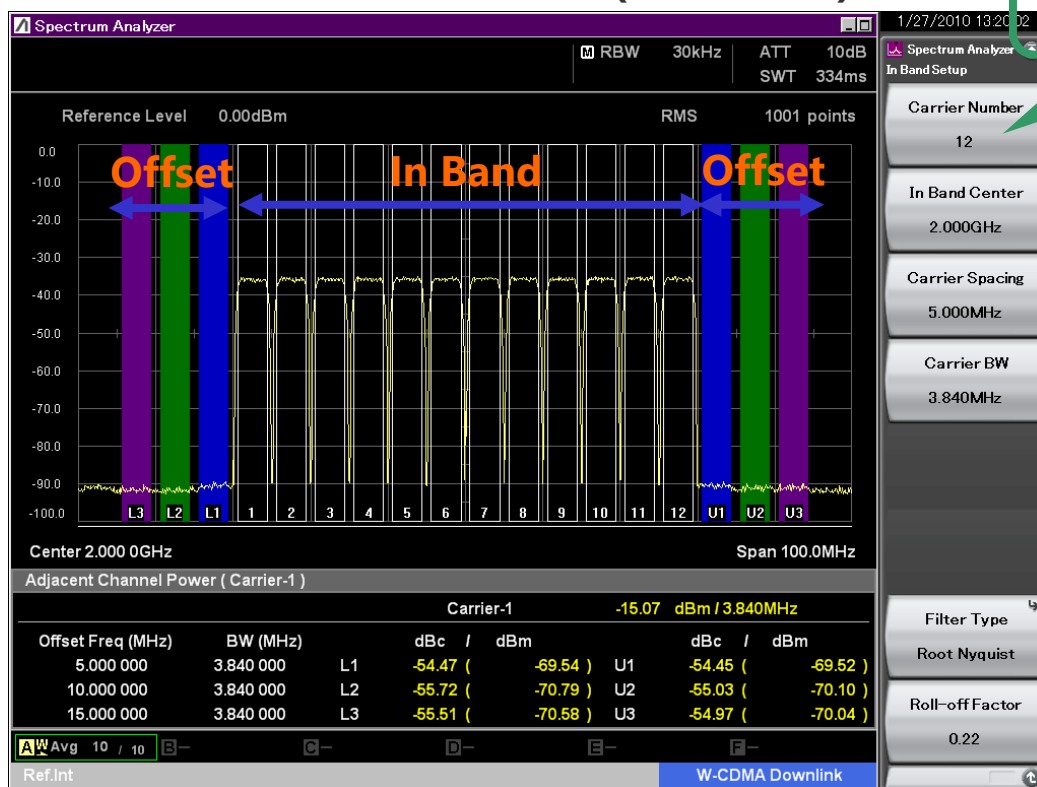

Carrier number switched instantaneously!



## Adjacent Channel Leakage Power (ACLR)

Offset Channel can be set from 1 to 8 and switched instantaneously on the screen.

### ACLR Measurement (12 carriers / 8 offsets)

Offset number switched instantaneously!

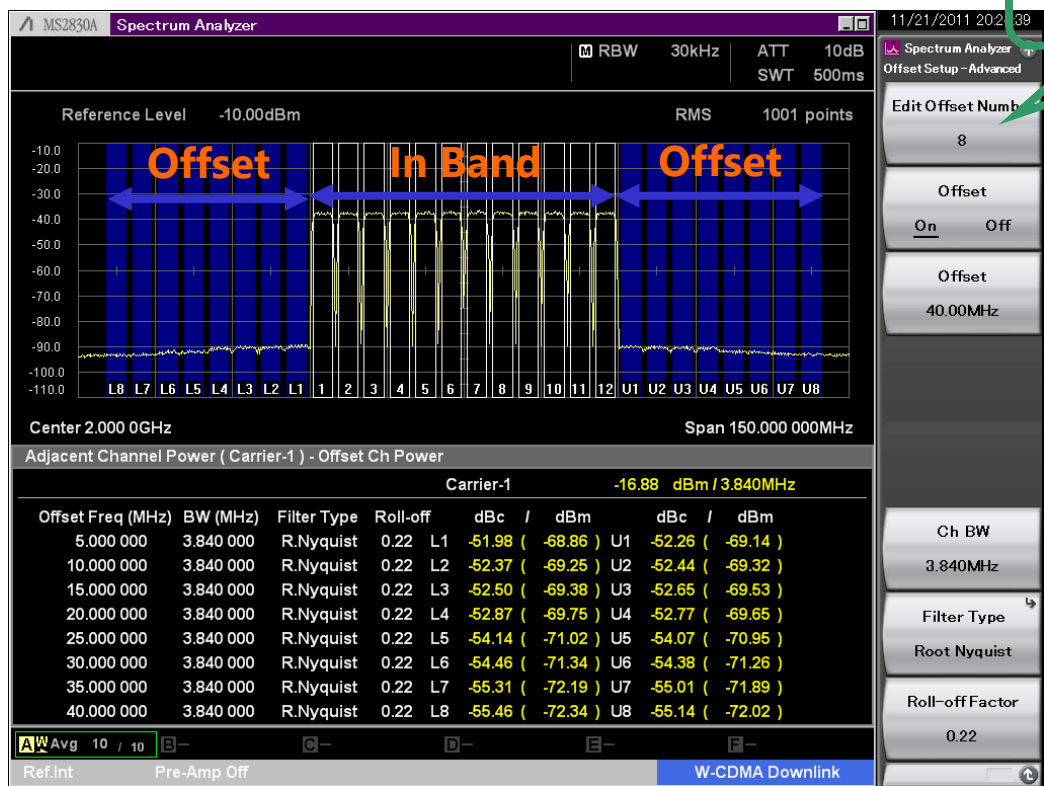



## Spectrum Emission Mask (SEM)

Offset limit lines can be set for up to 12 segments. The peak frequency and level in each segment are displayed and parts exceeding the limit line are indicated in red. Also, when a limit line is exceeded at just one part, Fail is displayed in red at the Result displays at the bottom left of the screen.

### Spectrum Emission Mask Measurement

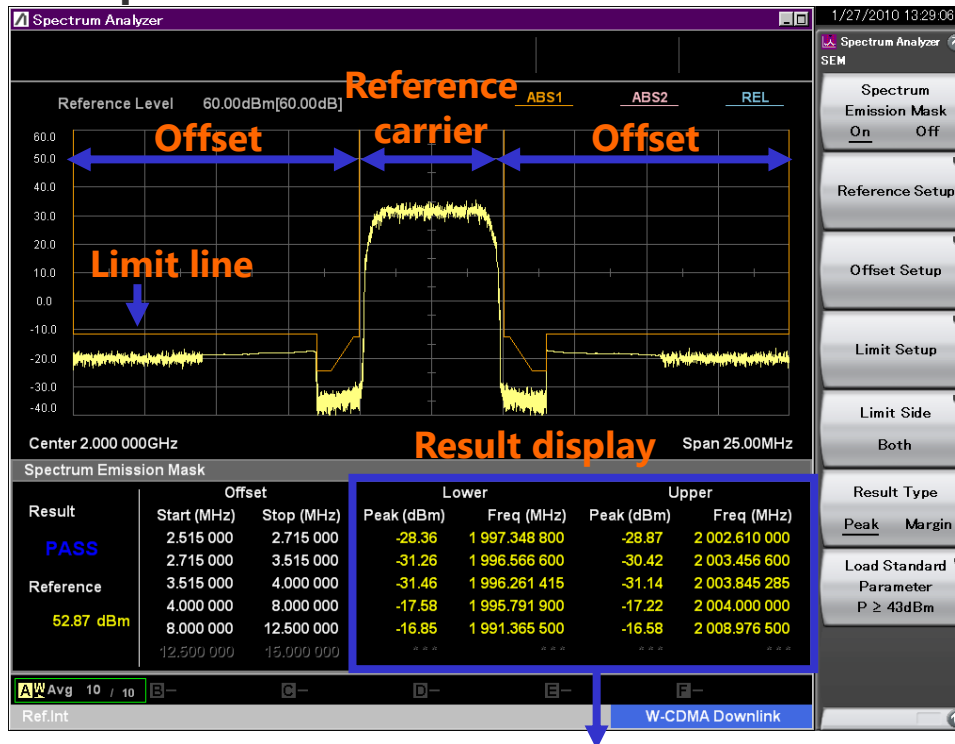

Measurement function ON/OFF

Reference carrier bandwidth and sweeping method setting

Offset position and sweeping method setting

Limit line setting (orange line)

Measurement target setting: (See below)

Result display switching

- Peak: Absolute power

- Margin: Margin for limit line

#### Measurement Target Setting

- Both: Measures both Lower and Upper
- Lower: Measures Lower
- Upper: Measures Upper

Level (Peak/Margin) and frequency of point closest to limit line per offset.



## Limit Lines

Up to six types of Limit line can be set on the spectrum display (frequency domain). In addition to setting the frequency and level of crossover points manually in sequence from the low frequency, after creating the right half of a line, the left half can be created by reversing and copying the right half, to set a symmetric limit line. Additionally, a Limit line that traces the measured waveform can be created using the Limit Envelope function. A margin can be set on the Limit line in the amplitude direction.

When the waveform is above or below the Limit line, it is evaluated automatically as PASS or FAIL. Evaluation is also possible with an added margin. The target evaluation line can be chosen from any of six types.

When the waveform matches the evaluation conditions (Event), it can be saved automatically as a csv format file. Any one of the following five Event types can be selected. (Save on Event Function)

- (1) Limit Fail: Saves waveform file when evaluation result is Fail
- (2) Limit Pass: Saves waveform file when evaluation result is Pass
- (3) Margin Fail: Saves waveform file when evaluation result including Margin is Fail
- (4) Margin Pass: Saves waveform file when evaluation result including Margin is Pass
- (5) Sweep Complete: Saves waveform file at every measurement regardless of evaluation result

Line: Limit 1, Limit 2, Limit 3, Limit 4, Limit 5, Limit 6  
 Evaluation Type: Upper Limit, Lower Limit  
 Crossover (Point): 1 to 100  
 Margin: Set Margin line for each Limit 1, 2, 3, 4, 5, 6  
 Evaluation Result: PASS, FAIL  
 Result Save: Auto-save as csv format file. (Save on Event Function)

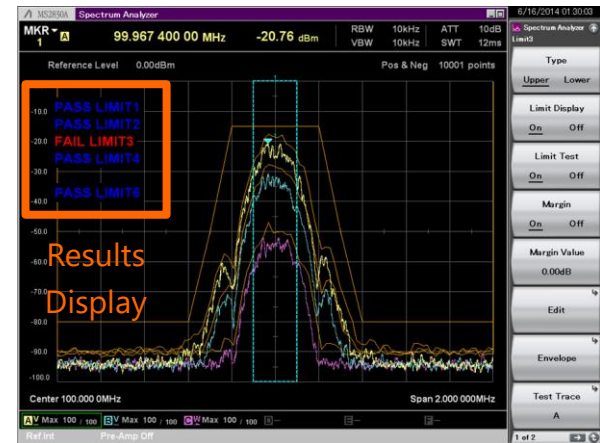

PASS/FAIL evaluation is performed by changing the input signal level. The evaluation results for the five line types can be displayed simultaneously on one screen.



## Average In-burst Power Measurement

The average power of specified burst segments is displayed in the time domain. Measurement only requires setting the measurement start and end positions on the screen.

### Average In-burst Power Measurement

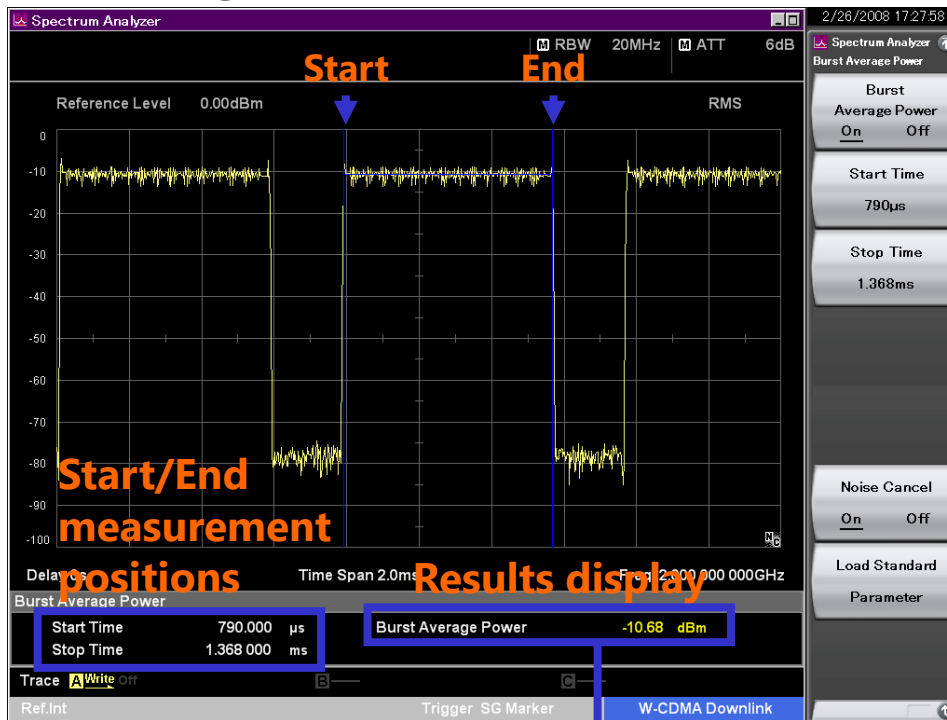

Measurement function ON/OFF

Measurement start position

Measurement stop position

Noise cancellation function ON/OFF  
(Subtracts main-frame noise from measurement result)

Displays average power between Start Time and Stop Time



## Spurious Emission

The peak frequency and level in each segment and the standard margin are displayed; parts exceeding the limit line are indicated in red. Also, Fail is displayed in red at the bottom left of the Results display even when the limit line is exceeded at only one part. A maximum of 20 segments can be set.

### Spurious Emission Measurement

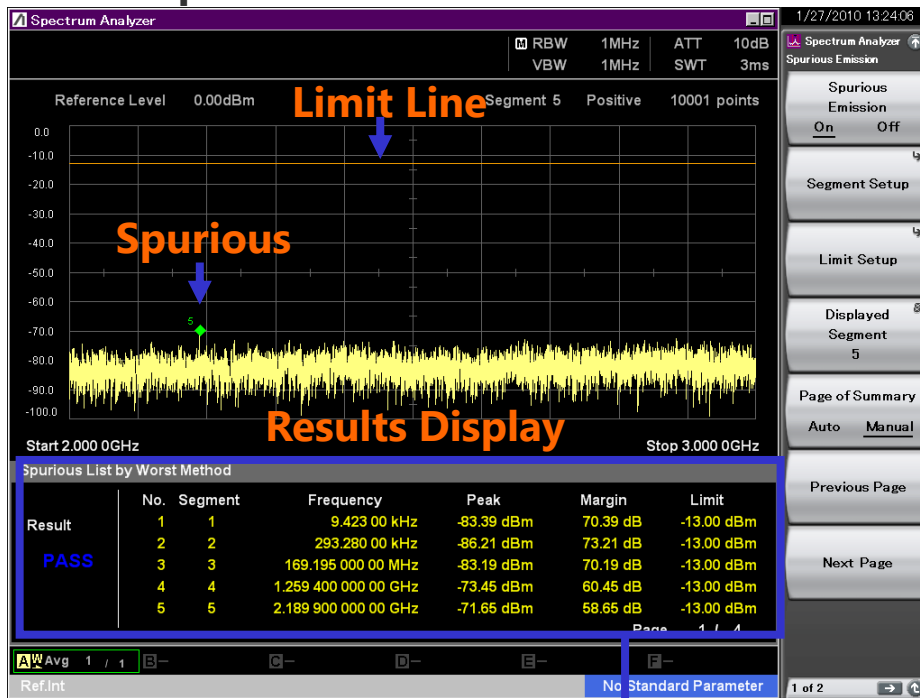

**Time Domain Measurement:**

- Spurious can be swept (detected) for up to 20 segments using the Zero Span measurement function.
- Different parameters (RBW/VBW) from segment sweeping can be set.
- Time domain measurements can be switched ON/OFF.

Detected spurious: Segment number, frequency, level (Peak/Margin), limit line



## AM: Power vs. Time

This function measures the amplitude modulation.

## FM Shift Measurement Function: Frequency vs. Time

This function measures frequency shift.



### AM Measurement

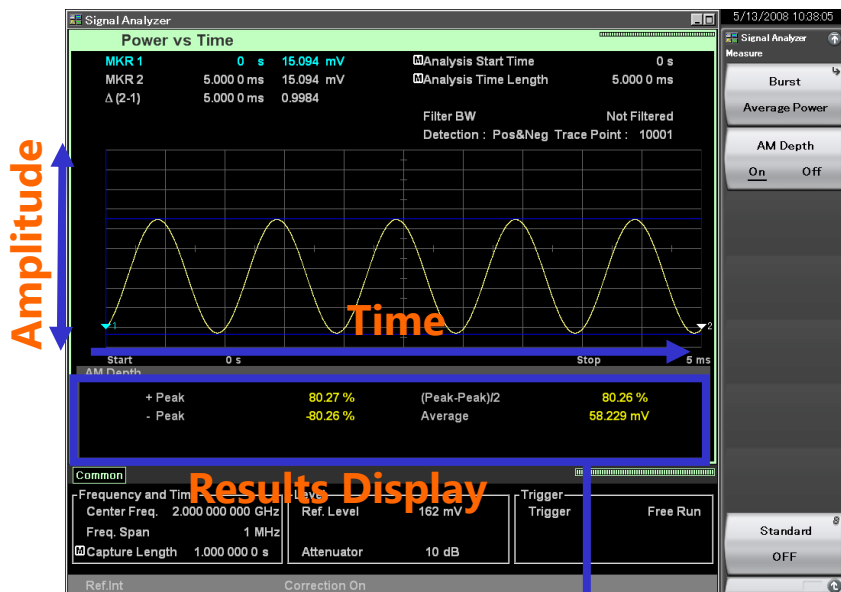

+ Peak, -Peak, (Peak-Peak)/2, average voltage between marker 1 and 2

### FM Shift Measurement

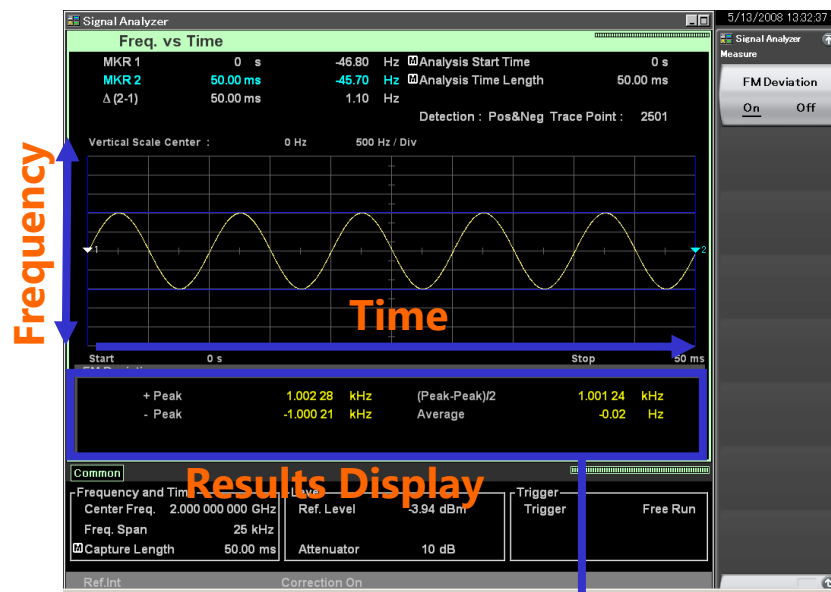

+ Peak, -Peak, (Peak-Peak)/2, average frequency between marker 1 and 2

## Phase Fluctuation Display Function: Phase vs. Time

This function displays phase time fluctuations.

### Phase Fluctuation Display



#### Phase Fluctuation:

Phenomena that are hard to spot using a spectrum analyzer, such as phase drift due to switching and transients, can be evaluated.



## Zone Marker Function

This displays the Peak value within the specified range. It is useful for measuring unstable signals with fluctuating frequency and noise.

## Multi-Marker/Highest 10 Function

This automatically searches for the ten highest peaks sorted from highest level (Sort Y) or lowest frequency (Sort X). In addition, setting a threshold eliminates unnecessary searching. This can be used for IM and harmonic, etc., measurements.



### IM Measurement

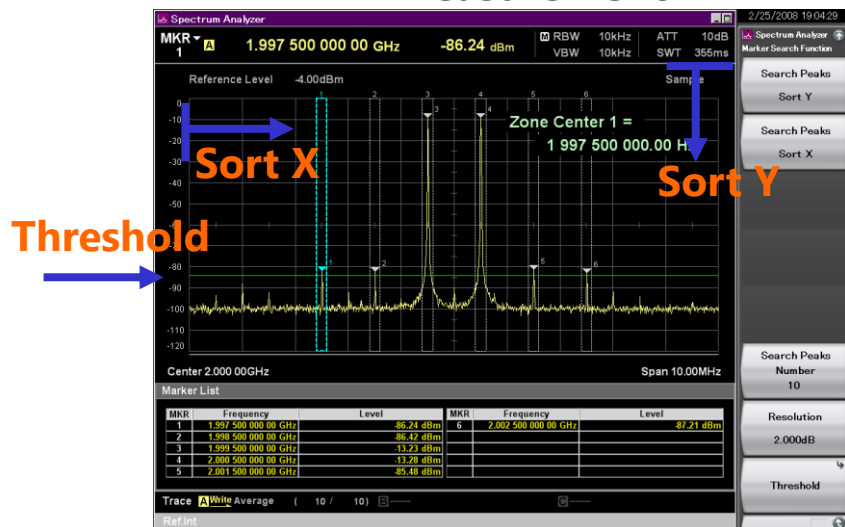

### Harmonic Measurement

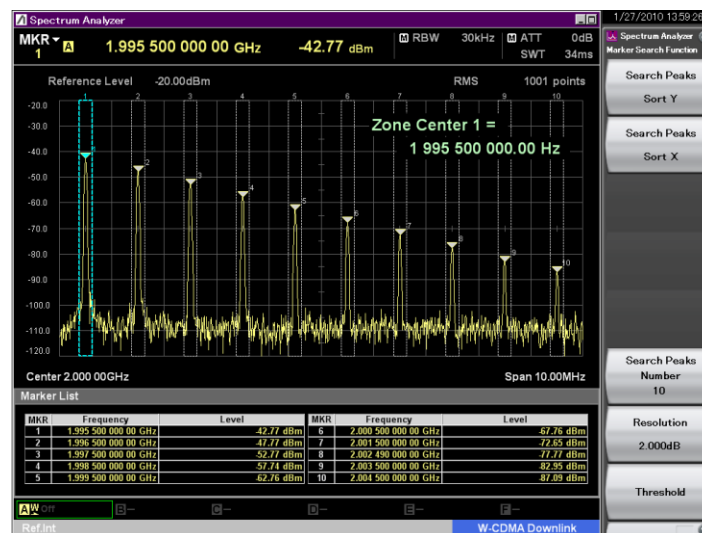

## Gate Sweeping

This function performs sweeping at the specified gate timing. The spectrum of the burst-on signal is easily displayed, etc., because sub-screens can be displayed simultaneously in the time domain.



## Frequency Counter

Set [Freq. Count] to ON to use the frequency counter function. [Gate Time] sets the frequency counter measurement time.

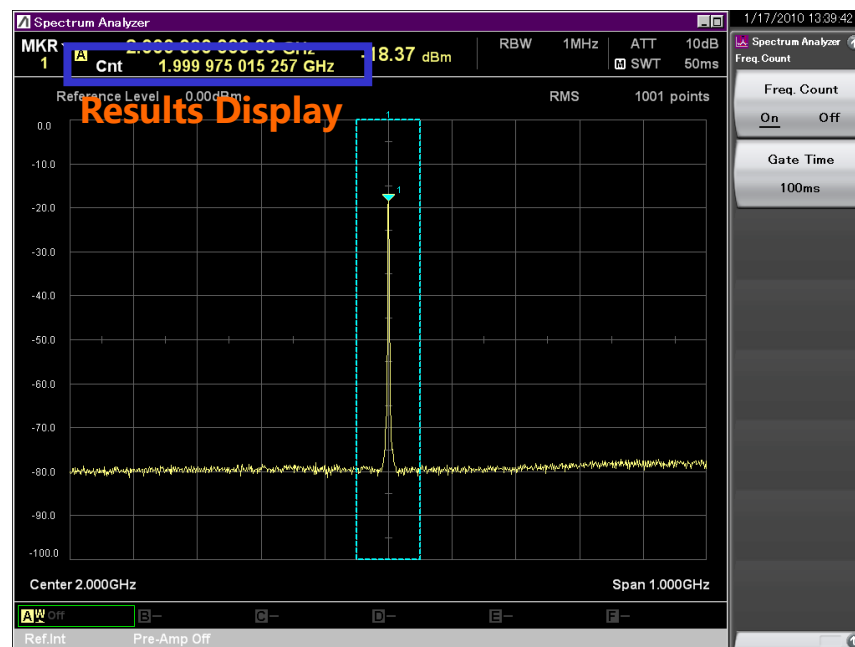
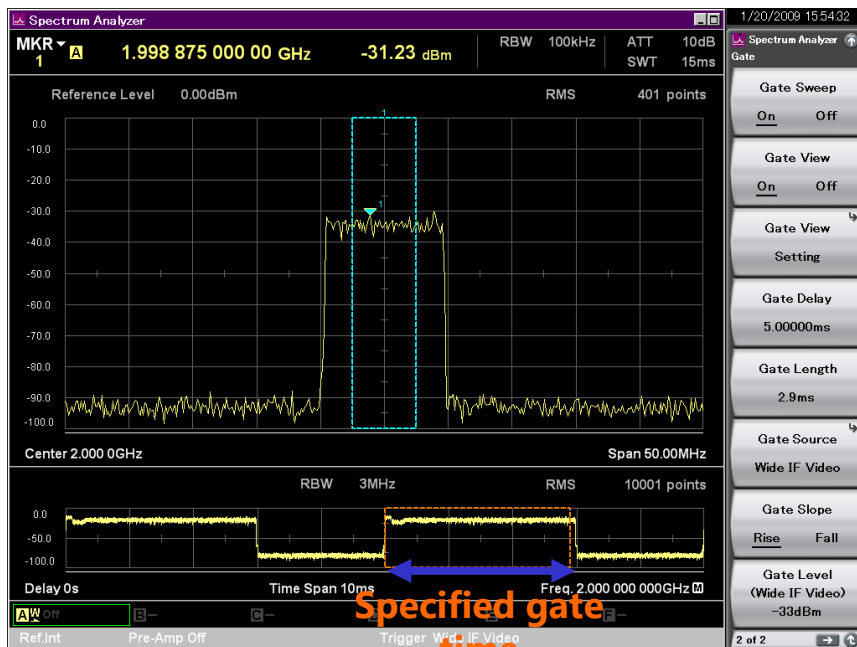

**Gate Time:**

Sets frequency counter measurement time



## 2-tone 3rd-order Intermodulation Distortion

By inputting two different frequency CW signals (desired waves), two-tone third order intermodulation distortion is generated close to the desired waves according to non-linear characteristics of DUT. Then, TOI (Third Order Intercept) is calculated from the two-tone third order intermodulation distortion.

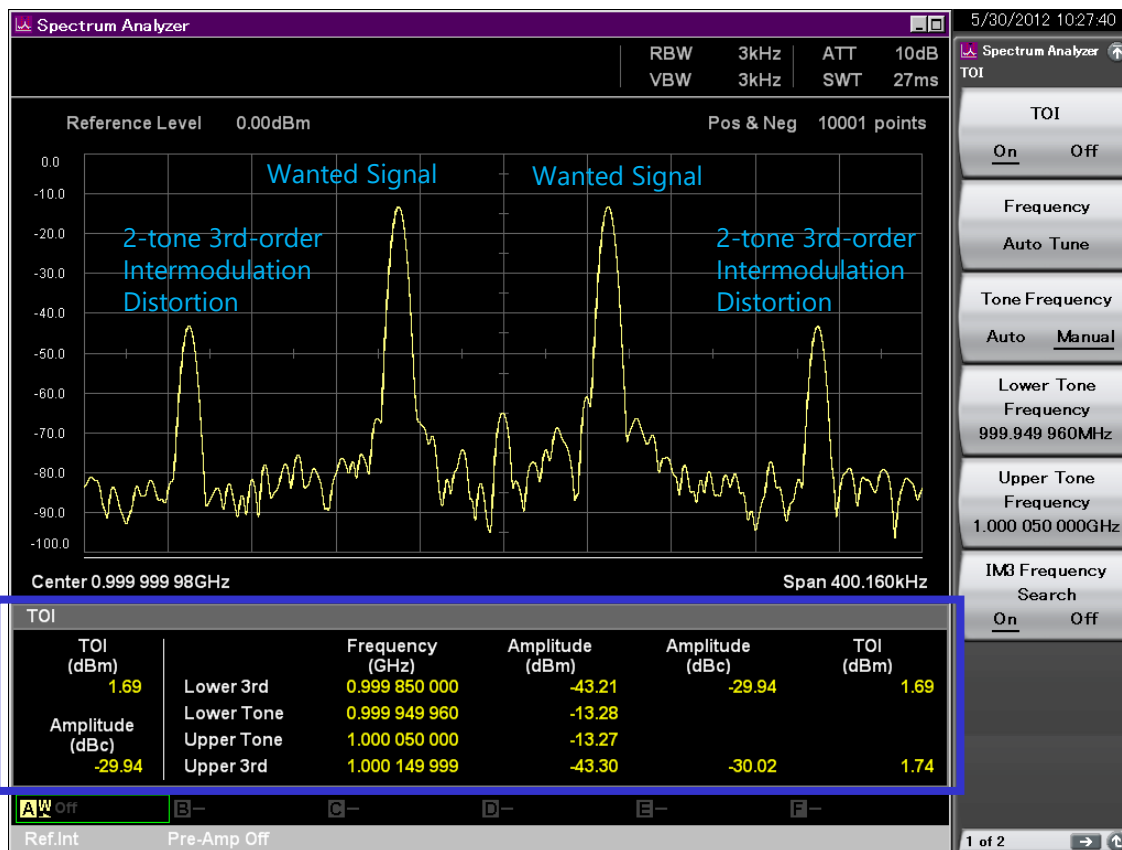

### Results Display

Item	Description
TOI (dBm)	Displays the calculated TOI. The Worst value (lower) between two calculated values (lower and upper) is displayed.
Amplitude (dBc)	Displays the level ratio of two-tone third-order intermodulation distortion to the desired wave. The Worst value (larger) between two calculated values (lower and upper) is displayed.
Lower 3rd	Two-tone third-order intermodulation distortion that occurs at the lower frequency of the desired wave. Frequency, signal level, level ratio to the desired wave, and calculated TOI are displayed.
Lower Tone	Desired wave that includes the lower frequency component. Frequency and signal level are displayed.
Upper Tone	Desired wave that includes the upper frequency component. Frequency and signal level are displayed.
Upper 3rd	Two-tone third-order intermodulation distortion that occurs at the upper frequency of the desired wave. Frequency, signal level, level ratio to the desired wave, and calculated TOI are displayed.



## Annotation Display (On/Off)

Screen annotations can be set to On or Off. Annotations about frequency, amplitude, etc., are not displayed at the Off setting.

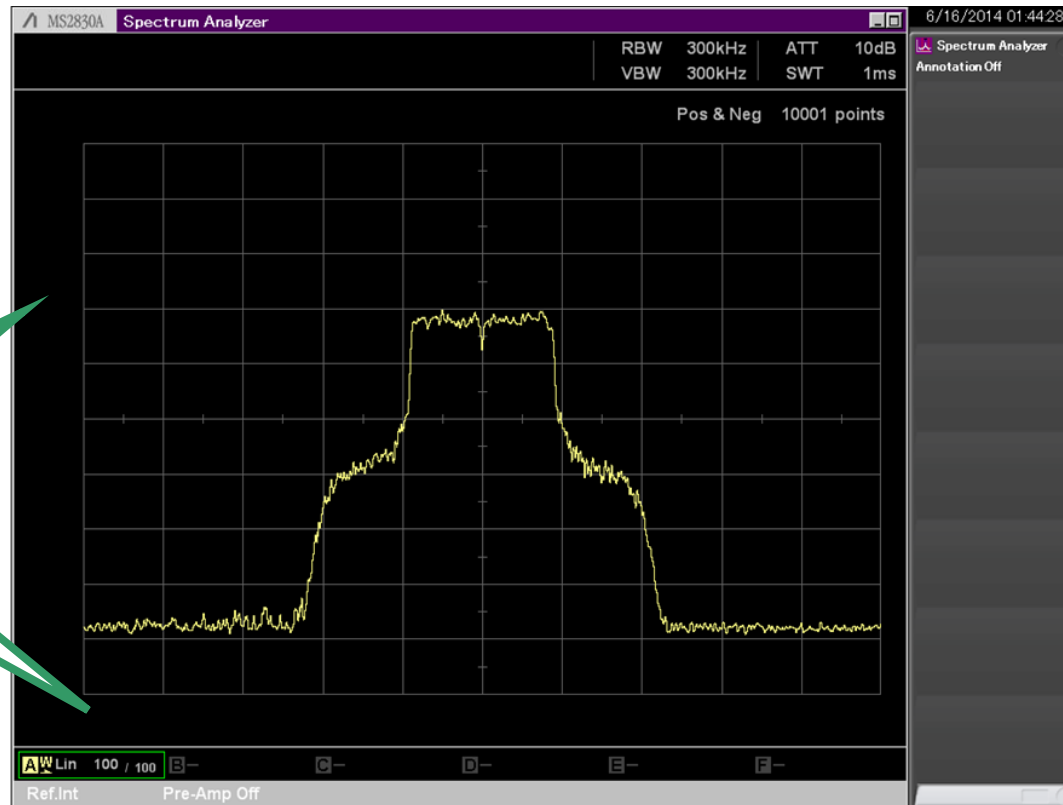

No annotations  
for frequency  
and amplitude



## Power Meter Function

Power meter function can connect a USB power sensor to the MS2830A and read the measurement values.

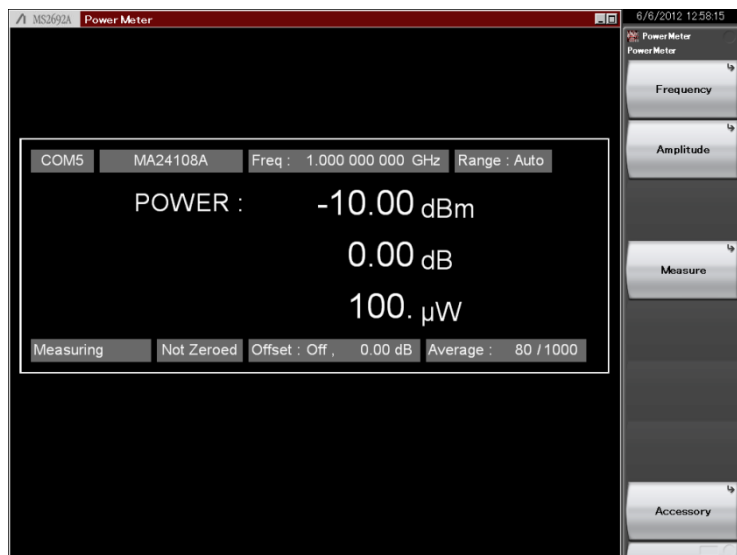

### Measurement Results

- Power: [dBm], [W]
- Relative power: [dB]

### Compatible USB power sensors

Model	Frequency	Dynamic Range
MA24104A*	600 MHz to 4 GHz	+3 to +51.76 dBm
MA24105A	350 MHz to 4GHz	+3 to +51.76 dBm
MA24106A	50 MHz to 6 GHz	-40 to +23 dBm
MA24108A	10 MHz to 8 GHz	-40 to +20 dBm
MA24118A	10 MHz to 18 GHz	-40 to +20 dBm
MA24126A	10 MHz to 26 GHz	-40 to +20 dBm

\*: MA24104A has been discontinued.

## Anritsu PowerXpert™ Measurement

Installing the Anritsu PowerXpert™ PC application software for the Anritsu USB Power Sensor in the MS2830A supports various measurement functions offered by Anritsu PowerXpert™, as well as use of other USB power sensors by the MS2830A.

Anritsu PowerXpert™ for the MS2830A can be downloaded from the MS2830A and MS2830A Microwave product pages at the Anritsu website. When using the Anritsu PowerXpert™ software with a PC, download the latest version from the USB Power Sensor product page at the Anritsu website.

## Phase Noise Measurement Function [MS2830A-010]

This function measures the phase noise over a frequency offset range of 10 Hz to 10 MHz.



### Normal:

Normal marker. Displays phase noise level at specified frequency offset.

### Integral Noise:

Calculates Integral Noise for specified integrated bandwidth

### RMS Noise:

Calculates RMS Noise for specified integrated bandwidth

### Jitter:

Calculates Jitter for specified integrated bandwidth

### Residual FM:

Calculates Residual FM for specified integrated bandwidth

### Carrier Frequency:

- 10 MHz to main frame upper limit
- Start Offset (lower limit frequency): 10 Hz to 1 kHz
- Stop Offset (upper limit frequency): 100 kHz to 10 MHz

### Log Scale Line(10/16):

- Sets number of Log scale lines to 10 or 16
- Reference Value: Sets upper limit of vertical axis
  - 140 to -50 dBc/Hz (Log Scale Line: 10)
  - 170 to -20 dBc/Hz (Log Scale Line: 16)

## Noise Figure Measurement Function [MS2830A-017]

Noise Figure is measured with the measurement method of Y-factor method which uses a Noise Source.]

**Frequency Mode: Fixed/List/Sweep**

**DUT Mode: Amplifier/Down Converter/Up Converter**

**Screen Layout: Graph/Table**

**Measurement Results Display**

■ **Graph/List/Spot**

Displays measurement results for each trace (Trace1/Trace2).

- ◆ Noise Figure (NF) [dB]
- ◆ Noise Factor (F) [Linear]
- ◆ Gain
- ◆ Y-Factor: Power ratio when Noise Source is turned ON/OFF
- ◆ T effective: Effective noise temperature
- ◆ P Hot: Power measured when Noise Source is On.
- ◆ P Cold: Power measured when Noise Source is Off.



Measurement Result: Example of Graph display (Frequency Mode: Sweep, Screen Layout: Graph)

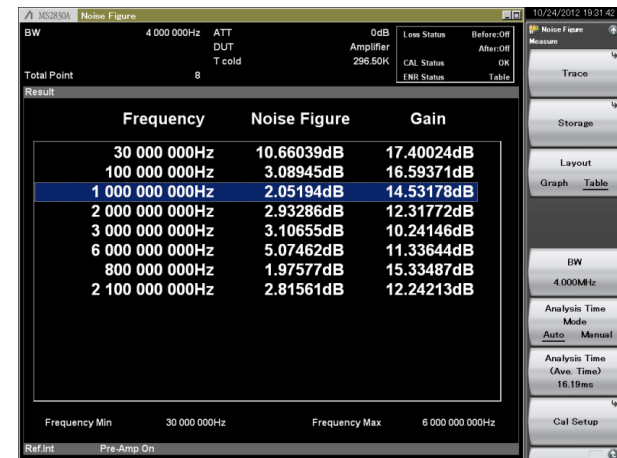

Measurement Result: Example of List display (Frequency Mode: List, Screen Layout: List)

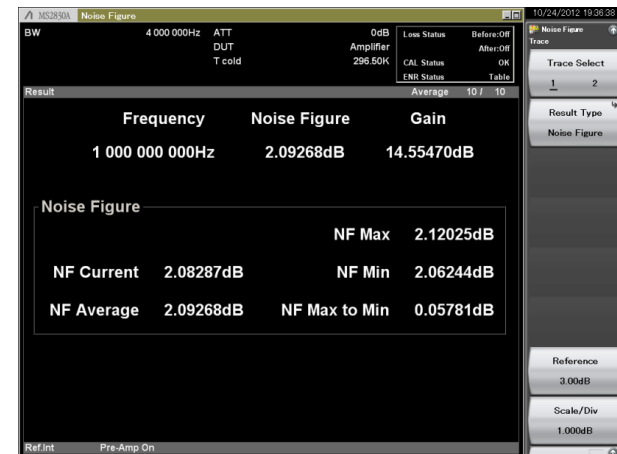

Measurement Result: Example of Spot display (Frequency Mode: Fixed)

## Noise Figure Measurement Function [MS2830A-017]

### Noise Source

Supports noise sources from Noisecom NC346 series. NC346 series models and summary specifications are listed below. See the NC346 series catalog and datasheet for detailed specifications.

### NC346 series summary specifications

Model	RF Connector	Frequency [GHz]	Output ENR [dB]	VSWR (maximum @ on/off) [GHz]				DC Offset	DC Block
				0.01 to 5	5 to 18	18 to 26.5	26.5 to 40		
NC346A	SMA (M)	0.01 to 18.0	5 to 7	1.15: 1	1.25: 1	—	—	No	Not required
NC346A Precision	APC3.5 (M)	0.01 to 18.0	5 to 7	1.15: 1	1.25: 1	—	—	No	Not required
NC346A Option 1	N (M)	0.01 to 18.0	5 to 7	1.15: 1	1.25: 1	—	—	No	Not required
NC346A Option 2	APC7	0.01 to 18.0	5 to 7	1.15: 1	1.25: 1	—	—	No	Not required
NC346A Option 4	N (F)	0.01 to 18.0	5 to 7	1.15: 1	1.25: 1	—	—	No	Not required
NC346B	SMA (M)	0.01 to 18.0	14 to 16	1.15: 1	1.25: 1	—	—	No	Not required
NC346B Precision	APC3.5 (M)	0.01 to 18.0	14 to 16	1.15: 1	1.25: 1	—	—	No	Not required
NC346B Option 1	N (M)	0.01 to 18.0	14 to 16	1.15: 1	1.35: 1	—	—	No	Not required
NC346B Option 2	APC7	0.01 to 18.0	14 to 16	1.15: 1	1.25: 1	—	—	No	Not required
NC346B Option 4	N (F)	0.01 to 18.0	14 to 16	1.15: 1	1.35: 1	—	—	No	Not required
NC346D	SMA (M)	0.01 to 18.0	19 to 25 <sup>*1</sup>	1.50: 1	1.50: 1	—	—	No	Not required
NC346D Precision	APC3.5 (M)	0.01 to 18.0	19 to 25 <sup>*1</sup>	1.50: 1	1.50: 1	—	—	No	Not required
NC346D Option 1	N (M)	0.01 to 18.0	19 to 25 <sup>*1</sup>	1.50: 1	1.75: 1	—	—	No	Not required
NC346D Option 2	APC7	0.01 to 18.0	19 to 25 <sup>*1</sup>	1.50: 1	1.50: 1	—	—	No	Not required
NC346D Option 3	N (F)	0.01 to 18.0	19 to 25 <sup>*1</sup>	1.50: 1	1.75: 1	—	—	No	Not required
NC346C	APC3.5 (M)	0.01 to 26.5	13 to 17	1.15: 1	1.25: 1	1.35: 1	—	Yes <sup>*3</sup>	Required <sup>*3</sup>
NC346E	APC3.5 (M)	0.01 to 26.5	19 to 25 <sup>*1</sup>	1.50: 1	1.50: 1	1.50: 1	—	Yes <sup>*3</sup>	Required <sup>*3</sup>
NC346Ka	K (M) <sup>*2</sup>	0.10 to 40.0	10 to 17	1.25: 1	1.30: 1	1.40: 1	1.50: 1	Yes <sup>*3</sup>	Required <sup>*3</sup>

\*1: Flatness better than ±2 dB

\*2: Compatible with SMA and APC3.5

**\*3: When using noise sources output by DC, always use in combination with a DC block.**

## Noise Figure Measurement Function [MS2830A-017]

### Specifications outlines of recommended DC Blocks and Adapters

	Ordering		RF Connector	Frequency Range
	Model	Name		
DC Block	J0805	DC Block, N type (MODEL 7003)	N (M)-N (F)	10 kHz to 18 GHz
	J1555A	DC Block, SMA type (MODEL 7006-1)	SMA (M)-SMA (F)	9 kHz to 20 GHz
	K261	DC Block	K (M)-K (F)	10 kHz to 40 GHz
Adapter	J0004	Coaxial Adapter	N (M)-SMA (F)	DC to 12.4 GHz
	J1398A	N-SMA Adapter	N (M)-SMA (F)	DC to 26.5 GHz

### Recommended DC blocks/Adaptor combinations for MS2830A/MS269xA series signal analyzer

	Model	Frequency Range	RF connector	Recommended DC Block Order Name	Recommended Adapter Order Name
MS2830A series	MS2830A-040	9 kHz to 3.6 GHz	N (F)	Not required	Not required
	MS2830A-041	9 kHz to 6 GHz	N (F)	Not required	Not required
	MS2830A-043	9 kHz to 13.5 GHz	N (F)	Not required	Not required
	MS2830A-044	9 kHz to 26.5 GHz	N (F)	J1555A (9 kHz to 20 GHz)	J1398A
	MS2830A-045	9 kHz to 43 GHz	K (F)	K261	Not required
MS269xA series	MS2690A	50 Hz to 6 GHz	N (F)	J1555A (from 9 kHz)	J0004
	MS2691A	50 Hz to 13.5 GHz	N (F)	J1555A (from 9 kHz)	J1398A
	MS2692A	50 Hz to 26.5 GHz	N (F)	J1555A (9 kHz to 20 GHz)	J1398A

## Captures wideband waveforms up to 125 MHz with accuracy of $\pm 0.3$ dB typ.

Based on the excellent level accuracy and wide dynamic range of the MS2830A, a signal with an FFT analysis bandwidth of up to 125 MHz can be captured with a level accuracy of  $\pm 0.3$  dB typ.

Max. Capture Time: 0.5 s to 2000 s  
Max. Number of Samples: 100 Msamples

Span*	Sampling Rate	Capture Time	Max. Sampling Data
1 kHz	2 kHz	2000 s	4M
2.5 kHz	5 kHz	2000 s	10M
5 kHz	10 kHz	2000 s	20M
10 kHz	20 kHz	2000 s	40M
25 kHz	50 kHz	2000 s	100M
50 kHz	100 kHz	1000 s	100M
100 kHz	200 kHz	500 s	100M
250 kHz	500 kHz	200 s	100M
500 kHz	1 MHz	100 s	100M
1 MHz	2 MHz	50 s	100M
2.5 MHz	5 MHz	20 s	100M
5 MHz	10 MHz	10 s	100M
10 MHz	20 MHz	5 s	100M
25 MHz	50 MHz	2 s	100M
31.25 MHz	50 MHz	2 s	100M
50 MHz	100 MHz	500 ms	50M
62.5 MHz	100 MHz	500 ms	50M
100 MHz	200 MHz	500 ms	100M
125 MHz	200 MHz	500 ms	100M

\*: With MS2830A-006: 1 kHz to 10 MHz

With MS2830A-005/006 (for MS2830A-044) or MS2830A-006/009 (for MS2830A-045): 1 kHz to 31.25 MHz

With MS2830A-005/006/077 (for MS2830A-044) or MS2830A-006/009/077 (for MS2830A-045): 1 kHz to 62.5 MHz

With MS2830A-005/006/077/078 (for MS2830A-044) or MS2830A-006/009/077/078 (for MS2830A-045): 1 kHz to 125 MHz

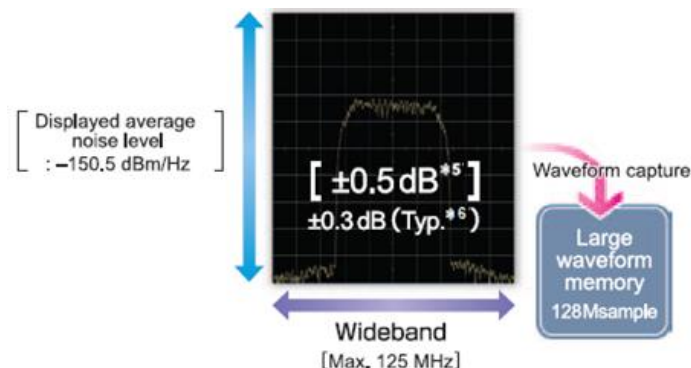

**MS2830A-006: 10 MHz max.**

(20 MHz max. sampling rate = 50 ns resolution, ADC resolution 16 bits)

**MS2830A-005\*1/ 009\*1\*2: 31.25 MHz max.**

(50 MHz max. sampling rate = 20 ns resolution, ADC resolution 16 bits)

**MS2830A-077\*2: 62.5 MHz max.**

(100 MHz max. sampling rate = 10 ns resolution, ADC resolution 14 bits)

**MS2830A-078\*3: 125 MHz max.**

(200 MHz max. sampling rate = 5 ns resolution, ADC resolution 14 bits)

Note) MS2830A-077/078: An image response is received when setting the bandwidth to more than 31.25 MHz. This can be used when not inputting a signal frequency outside the MS2830A analysis bandwidth (125 MHz max.). The Signal Analyzer MS2690A is recommended for other measurement purposes.

\*1: MS2830A-005 can be installed in MS2830A-044. Requires MS2830A-006.

\*2: MS2830A-009 can be installed in MS2830A-045. Requires MS2830A-006.

\*3: Requires MS2830A-006 and MS2830A-005 (for MS2830A-044). Requires MS2830A-006 and MS2830A-009 (for MS2830A-045).

\*4: Requires MS2830A-006, MS2830A-005 and MS2830A-077 (for MS2830A-044). Requires MS2830A-006, MS2830A-009 and MS2830A-077 (for MS2830A-045).

\*5:  $300 \text{ kHz} \leq f < 4 \text{ GHz}$ , Frequency band mode Normal.

\*6: Excluding Guard Band

## No need for calibration block at analysis tool side

The MS2830A has built-in amplitude/phase calibration circuits to automatically calibrate internal errors.

Captured waveform data are saved to the built-in hard disk and can be output to an external PC via 1000BASE-T.

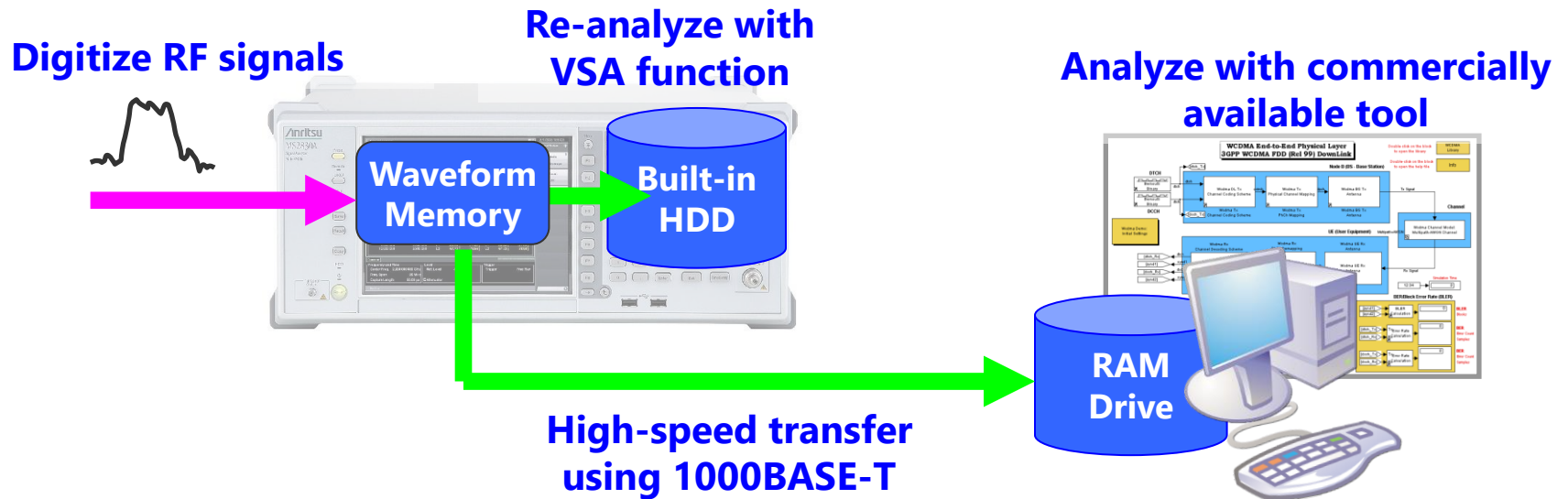

Various VSA analyses can be performed on the main trace by specifying analysis segments on the sub-trace. Intuitive analysis focusing on signal-on/rising/falling, etc., parts is made easy by observing signal distributions on the sub-trace.

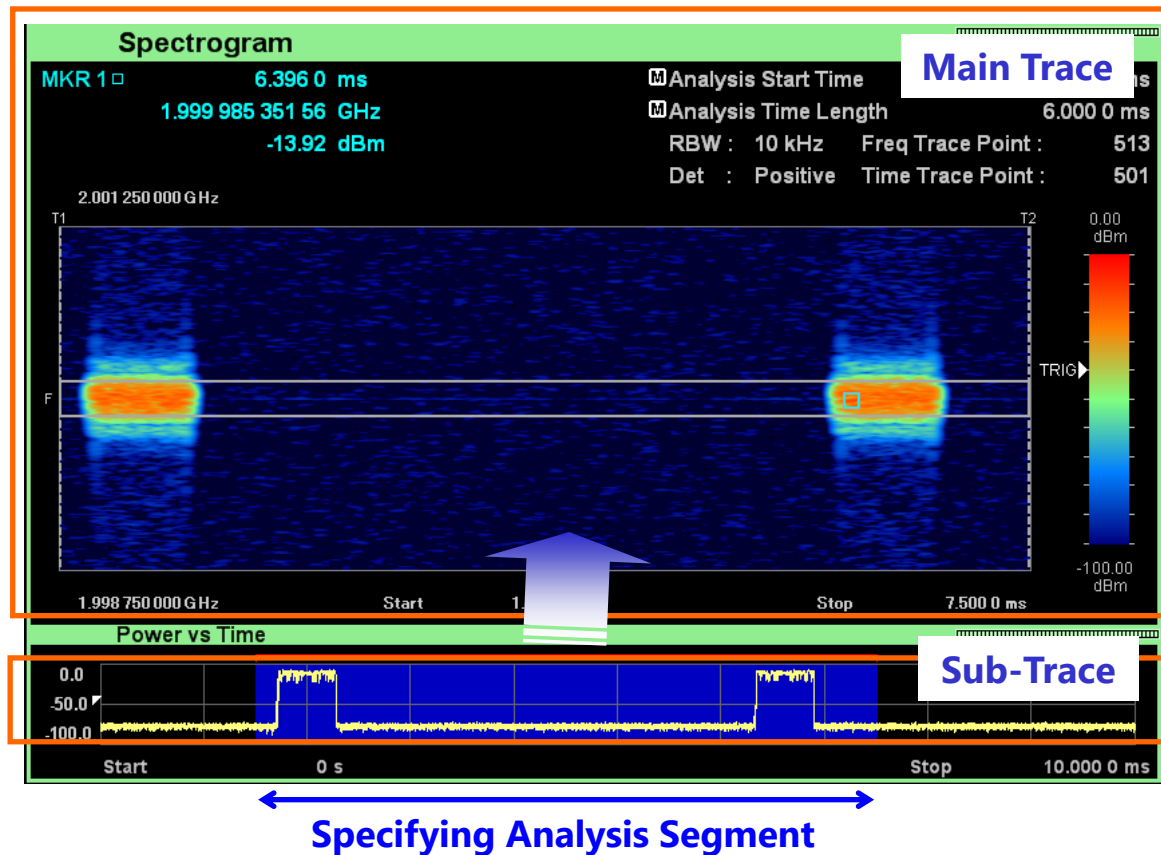

## Main Trace

- ◆ Spectrum
- ◆ Power vs. Time
- ◆ Frequency vs. Time
- ◆ Phase vs. time
- ◆ CCDF/APD
- ◆ Spectrogram

## Sub-trace

- ◆ Power vs. Time
- ◆ Spectrogram



# VSA Function: One-Step Observation of Rising/Falling Signals

Changing the analysis segment at the sub-trace permits frame-by-frame replay of the spectrum at the main trace.

This function supports troubleshooting by frame-by-frame replay of transient burst responses and generation of unwanted spurious in captured RF signals.

Changing the analysis section supports frame-by-frame replay of the rising signal.

### Sub-Trace (Spectrogram)

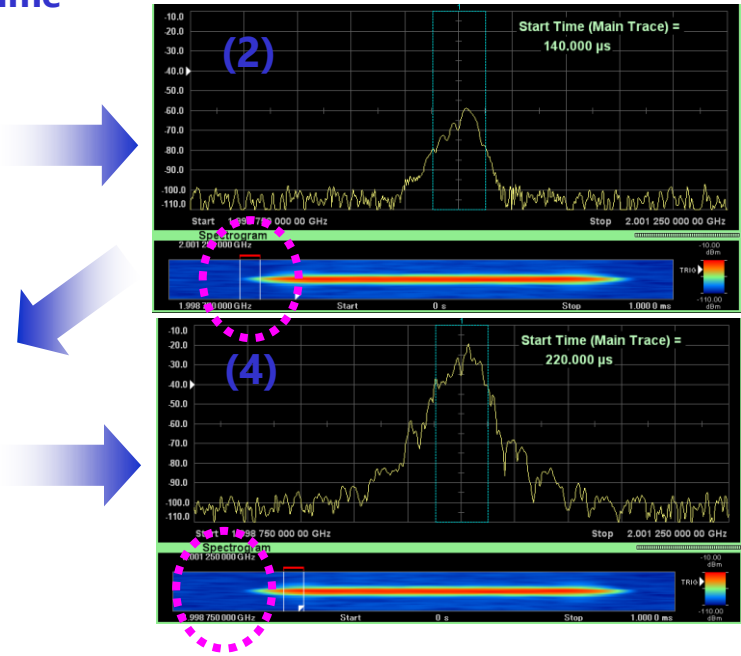
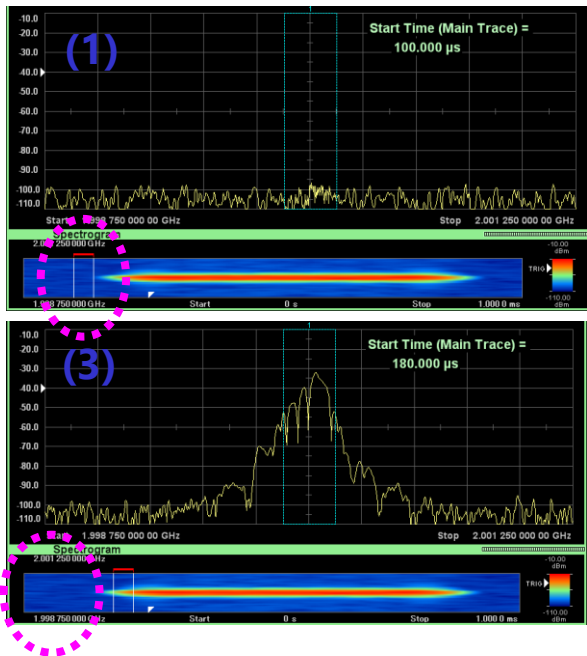
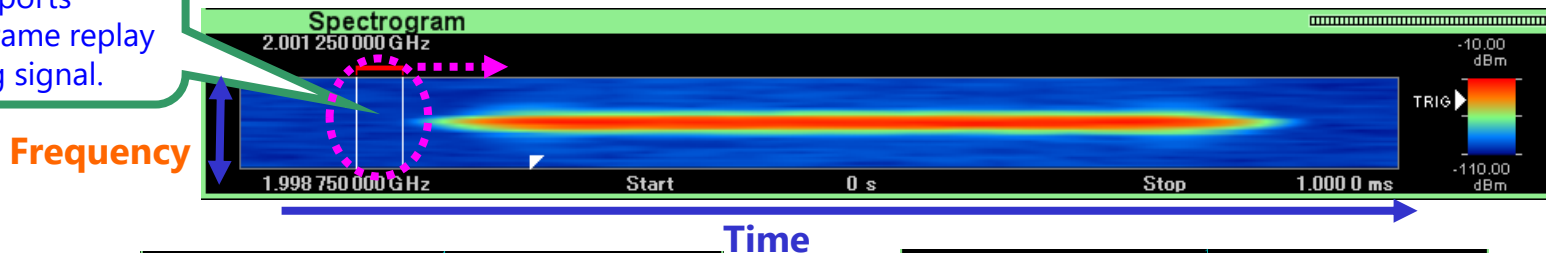

# VSA Function: Useful Replay Function for Comparative Verification

Captured waveforms can be replayed again by using the VSA function to read saved digitize data.

This is convenient for comparing performance of each DUT test phase using digitized data as well as for troubleshooting post-shipment product faults

## Digitize Data File Selection Screen

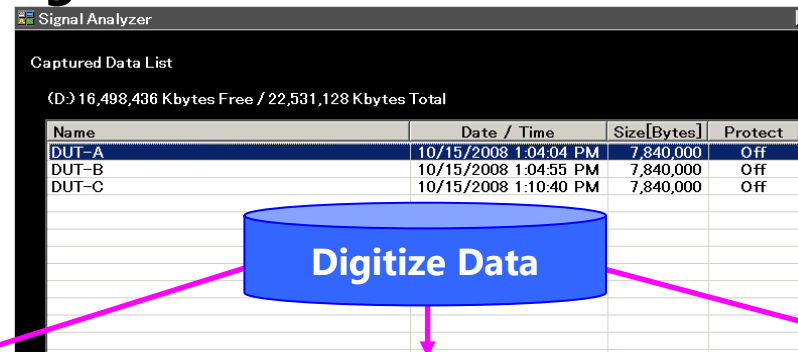

DUT (A)

DUT (B)

DUT (C)

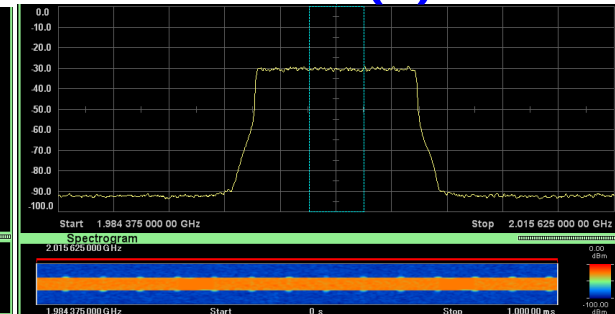
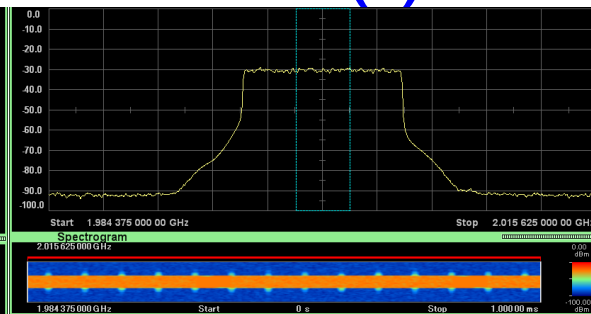
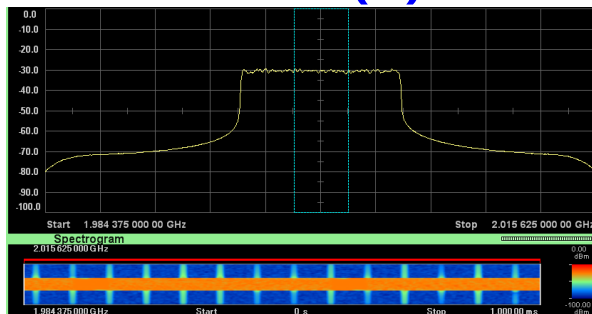

# VSA Function: File Saving Function

Captured data can be saved to a file by specifying the Analysis Time range (display range of main trace) or any time. The amount of saved data and later workload are cut because only required segments are captured and saved to a file.

Example: Capture 20 ms and save only one burst (600  $\mu$ s) of GSM signal to file.

Save required segment to file.

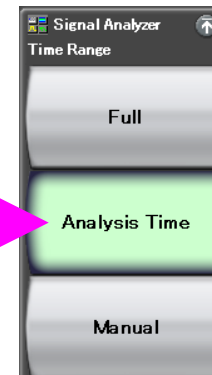
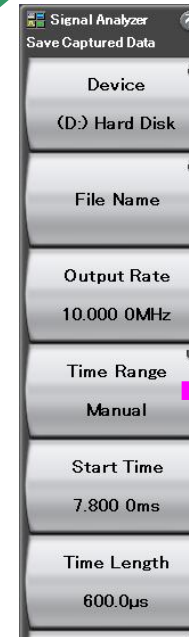
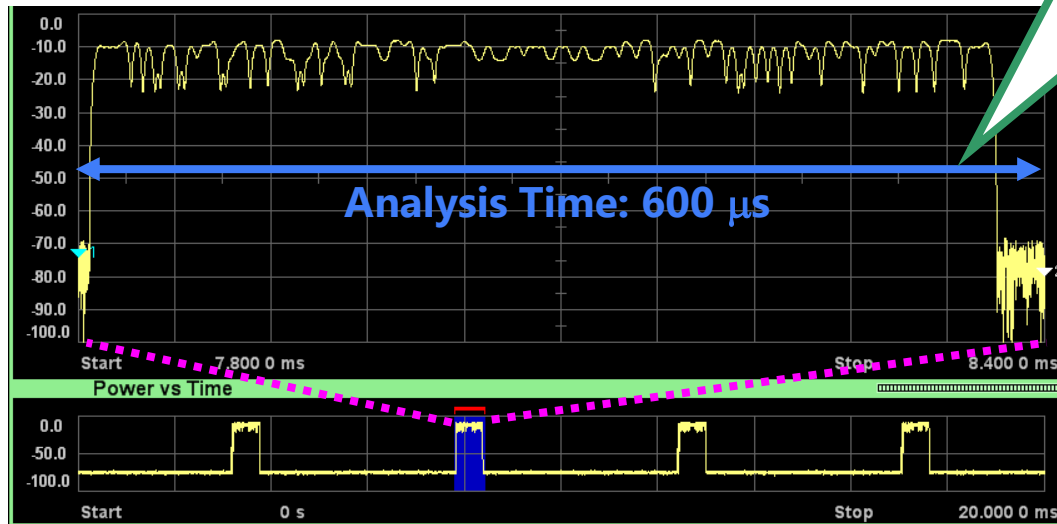

Save total capture time.

Save data specified by Analysis Time.

Save time-specified data.

# VSA Function: FFT Analysis Advantages Ultra High Speed

Supports measurements many times faster than a sweep spectrum analyzer by using the signal analyzer mode, which performs FFT analysis.

## Spectrum Analyzer

SPAN 25 MHz  
RBW 30 kHz

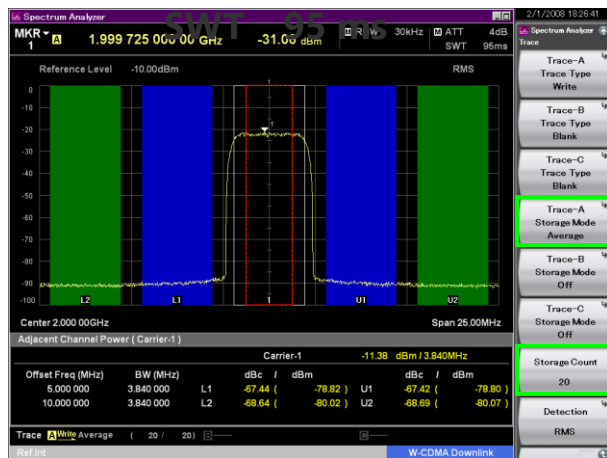

20 Averagings

Measurement Time 2.6 sec\*

## Signal Analyzer

SPAN 25 MHz  
RBW 30 kHz  
Analysis Length 95  $\mu$ s



20 Averagings

Measurement Time 0.3 sec

SPAN 25 MHz  
RBW 30 kHz  
Analysis Length 1900  $\mu$ s

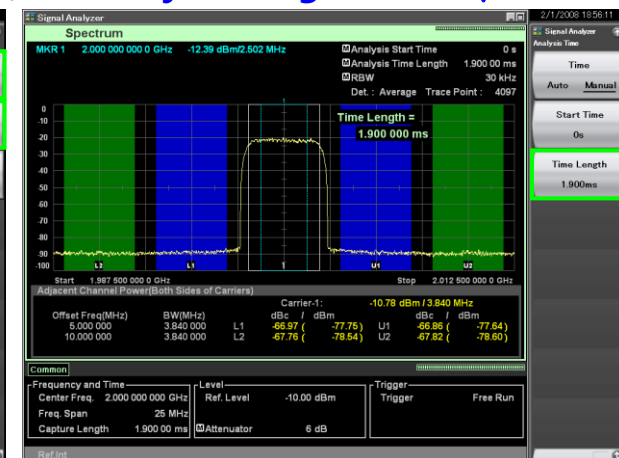

Batch Capture 20 Times

Measurement Time 0.04 sec

8 Times Faster

65 Times Ultra Fast

\*: Spectrum Analyzer measurement times measured with the MS269xA.

No Trace mode does not execute signal analysis. Therefore, “IQ data output” and “IQ data readout using remote commands” can be executed quickly without the need to wait for completion of analysis.

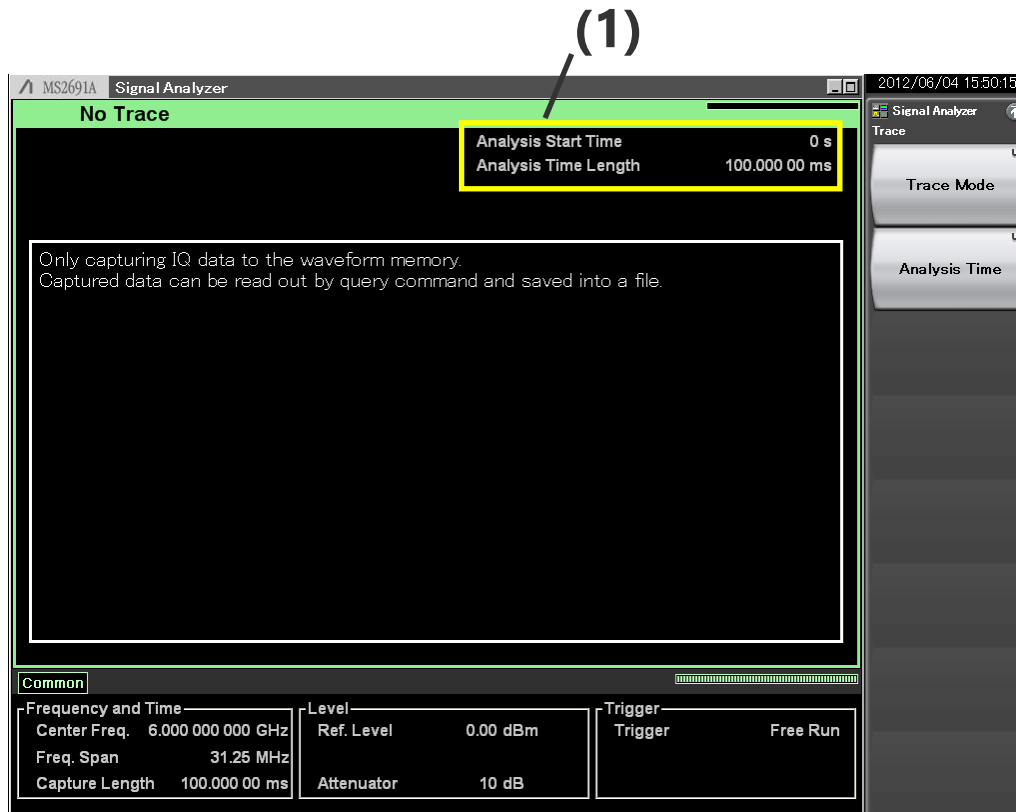

(1)	Analysis Start Time Analysis Time Length
	Displays “Analysis Start Time” and “Analysis Time Length”.

\*: As analysis is not executed, Save Waveform function for saving waveform data cannot be used.

## BER Measurement Function [MS2830A-026]

Returns Data/Clock/Enable demodulated by DUT to MS2830A BER function

- ◆ Input Bit Rate: 100 bps to 10 Mbps
- ◆ Input Signal: Data, Clock, Enable  
(Polarity reversal supported)
- ◆ Input Level: TTL 3.3V
- ◆ Measured Patterns:  
PN9/11/15/20/23, ALL1, ALL0,  
Alternate(0101...), User Data(4,096 bit Max.),  
PN9fix/11fix/15fix/20fix/23fix
- ◆ Count Mode:  
Data: Measures until specified Data count  
Error: Measures until specified Error count
- ◆ Measurable Bit Count: 1000 to  $2^{32}-1$   
(4,294,967,295 bit)
- ◆ Measurable Error Bit Count: 1 to  $2^{31}-1$   
(2,147,483,647 bit)
- ◆ Count Mode:  
Single: Measures specified measurement bit  
count once  
Continuous: Repeats Single measurement  
Endless: Continues measurement to upper limit  
of measurement bits

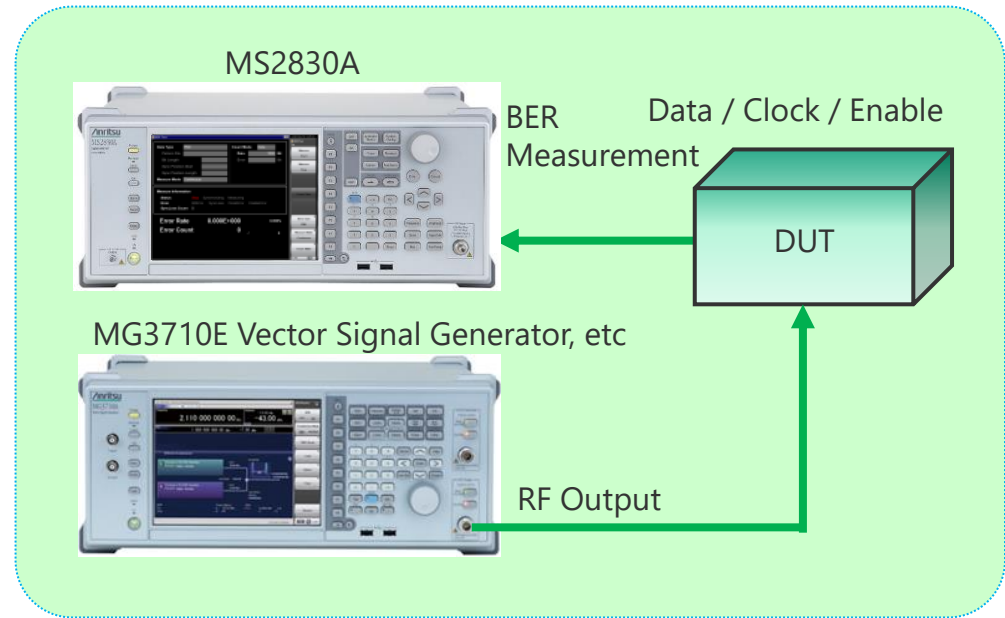

BER Measurement Setup Example  
(using external vector signal generator)

**This option installs a BER measurement function for measuring error rates between 100 bps and 10 Mbps using the DUT demodulated Data/Clock/Enable signals. The results are displayed on the MS2830A screen.**

## BER Measurement Function [MS2830A-026]

**BER Measurement Example**

**Annotations:**

- BER Test Start or Stop (Measure Start/Stop)
- Clears measurement result (Count Clear)
- Data Type (PN9)
- Measure Mode (Single)
- Count Mode (Data)
- Error Rate (1.008E-002)
- Error Bit (97)
- Measured Bit (9620)

### Measure Mode

Single: Measures selected data patterns until result reaches specified number of bits or specified number of error bits

Continuous: Repeats single measurements (default)

Endless: Measures data until result reaches upper limit of measurement count bit

### Count Mode

Data: Specifies number of measurement bits (default)

Error: Specifies number of measurement error bits

## BER Measurement Function [MS2830A-026]

### [PN Fix pattern]

At BER measurement, special PN patterns called PN\_Fix patterns can be used. A PN Fix pattern consists of repeated parts of PN patterns, and PN patterns with a shorter length than 1 cycle.

Even when the PN data part of the waveform pattern output from vector signal generator has no periodicity, BER measurement is supported by selecting PN Fix at the BER measurement function.

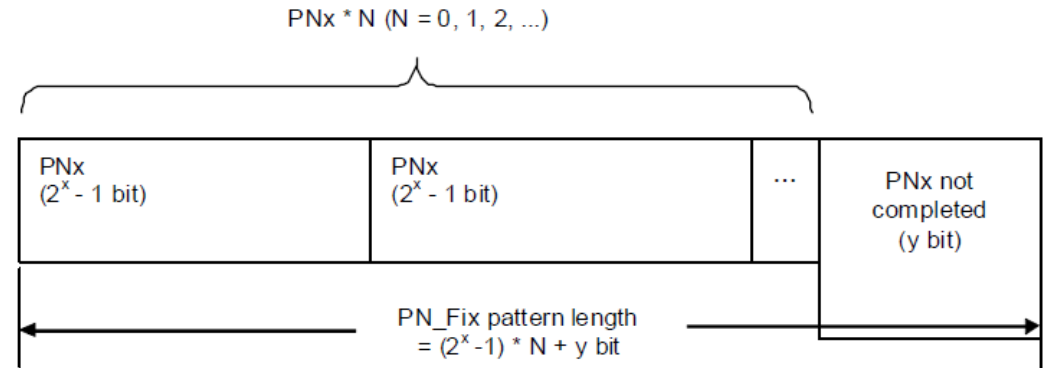

x: PN order  
N: Repetition count of PNx

### Initial Pattern

Data Type	Initial Pattern Setting Range		Resolution	Default
	Binary	Hex		
PN9Fix	000000000 to 111111111 (9 bits)	000 to 1FF	1	1FF
PN11Fix	00000000000 to 11111111111 (11 bits)	000 to 7FF	1	7FF
PN15Fix	000000000000000 to 111111111111111 (15 bits)	0000 to 7FFF	1	7FFF
PN20Fix	0000000000000000000 to 1111111111111111111 (20 bits)	00000 to FFFFF	1	FFFFF
PN23Fix	000000000000000000000 to 111111111111111111111 (23 bits)	000000 to 7FFFFFF	1	7FFFFFF

### Pattern Length

Setting Range:  
96 to 134217728 bit (0 x 8000000)  
Resolution: 1 bit



## BER Measurement Function [MS2830A-026]

### [User Defined Pattern]

The BER measurement can use a user-defined pattern, which is an arbitrary binary string that is 8- to 4096 bits long and consists of a data bit string to determine whether synchronization is established plus a data bit string used as measurement data. A PC can be used to create a user-defined pattern in text file format. Load the file from USB memory or MS2830A internal hard disk.

Length: 8 to 4096 (Binary)

Extension: \*\*\*\*\*.bpn

Saved Folder: the root directory of the USB memory or internal hard disk (Example: D:¥)

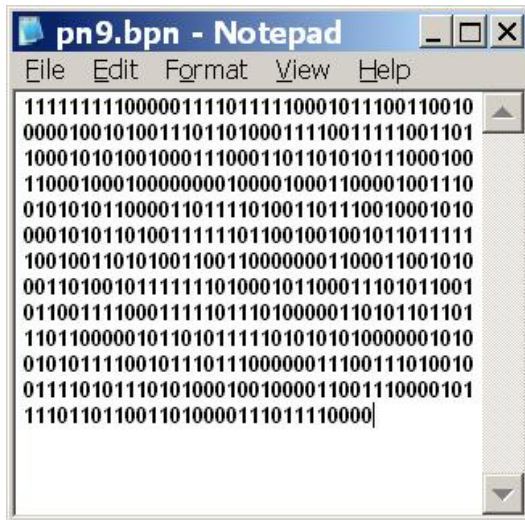

Example of User-Defined Pattern

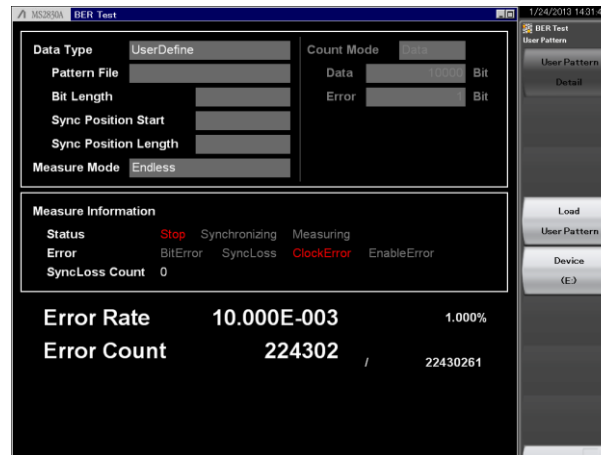

Loads user-defined patterns from the USB memory or the internal hard disk of the MS2830A.

Selects the media among the USB memory and internal hard disk from which user-defined patterns are to be loaded.

User-Defined Pattern function menu

## Software download service

This service, which provides updated versions of firmware and software for downloading by product customers, is available on Anritsu's website.

Download software list

Firmware / Software	Contents	Available version
<b>MS2830A Software Installer</b>	<b>MX269000A Standard Software</b> This software is installed as standard when shipping the main frame. Spectrum Analyzer function, Signal Analyzer function, etc. <b>MX2690xxA series Measurement Software</b> Measurement software for various communication systems.	The latest version is available on the website.

User registration is required for using the software download service.

User registration can be performed on the Anritsu website:

<https://login.anritsu.com/signin>



**Anritsu**  
Advancing beyond