

Guide to Spectrum and Signal Analysis

Introduction

Engineers and technicians involved in modern RF or microwave communications have many measuring instruments at their disposal, each designed for specific measurement tasks. Among those available are:

- a) **The Oscilloscope** – primarily developed for measuring and analyzing signal amplitudes in the time domain. (Voltage vs. time) Often 2, 4 or more channels of voltage vs. time can be viewed on the same display to show the relationships between signals. Extensive methods to trigger signals are often available to capture and display rare events.
- b) **The Spectrum Analyzer** – designed to measure the frequency and amplitude of electromagnetic signals in the frequency domain. (Frequency vs. time) Most modern analyzers also have the capability to demodulate analog modulated signals. Spectrum analyzers are the most versatile tools available to the RF engineer. This guide will describe the critical performance characteristics of spectrum and signal analyzers, the types of signals measured, and the measurements performed.
- c) **The Signal Analyzer** – invaluable for measuring the modulation characteristics of complex signals. These units capture and process blocks of spectrum to reveal amplitude and phase relationships between signals. Newer models provide demodulation of digitally modulated signals used in most of today's communications systems.
- d) **The Signal Generator** – an essential item of equipment for any communications test laboratory or workshop. The cost of a signal generator largely depends on the additional functions and facilities available as well as the type and quality of the frequency reference used.
- e) **The Field Strength Meter (F.S.M.)** – display the power density of an electrical signal incident on a calibrated antenna and thus give a direct reading of field strength in dB μ V/m.
- f) **The Frequency Counter** – a digitally based instrument that measures and displays the frequency of incoming signals. Some models can also count 'pulse' and 'burst' signals.

Frequency Domain/Time Domain

As mentioned in the introduction, electromagnetic signals can be displayed either in the time domain, by an oscilloscope, or in the frequency domain using a spectrum or signal analyzer. Traditionally, the time domain is used to recover the relative timing and phase information required to characterize electrical circuit behavior. Many circuit elements such as amplifiers, modulators, filters, mixers and oscillators are better characterized by their frequency response information. This frequency information is best obtained by analysis in the frequency domain. Modern Oscilloscopes provide frequency domain display modes and modern Spectrum and Signal analyzers provide time domain displays. One key difference between oscilloscopes and spectrum/signal analyzers is the resolution of the vertical axis. Oscilloscopes provide high resolution along the time axis but low (8 bit) amplitude resolution. Spectrum and signal analyzers provide high (16 bit or more) amplitude resolution to see small signals in the presence of large signals.

In order to visualize these 'domains' refer to Figure 1.

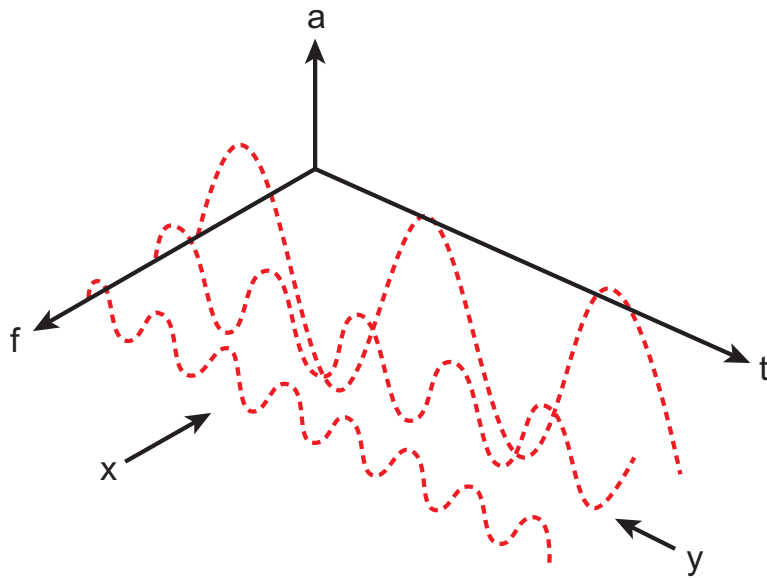

Figure 1

This represents an electromagnetic signal as a three dimensional model using:

- (i) a time axis (t)
- (ii) a frequency axis (f) and
- (iii) an amplitude axis (a)

Observing from position X produces an amplitude time display where the resultant trace is the sum of the amplitudes of each signal present. This time domain view facilitates analysis of complex signals, but provides no information on the individual signal components (Figure 2).

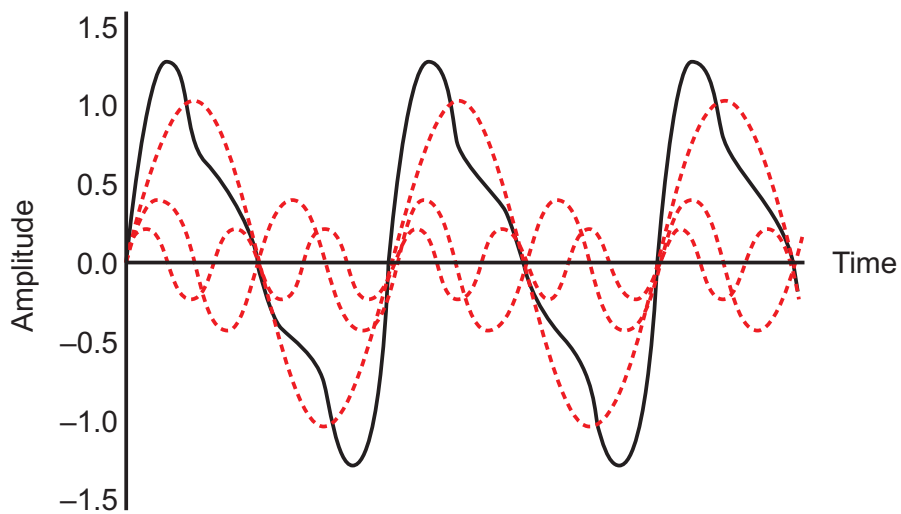

Figure 2

Viewing the model in Figure 1 from position Y, however, produces an amplitude vs. frequency display showing each component of the signal in the complex waveform. Observation in this frequency domain permits a quantitative measurement of the frequency response, spurious components and distortion of circuit elements (Figure 3).

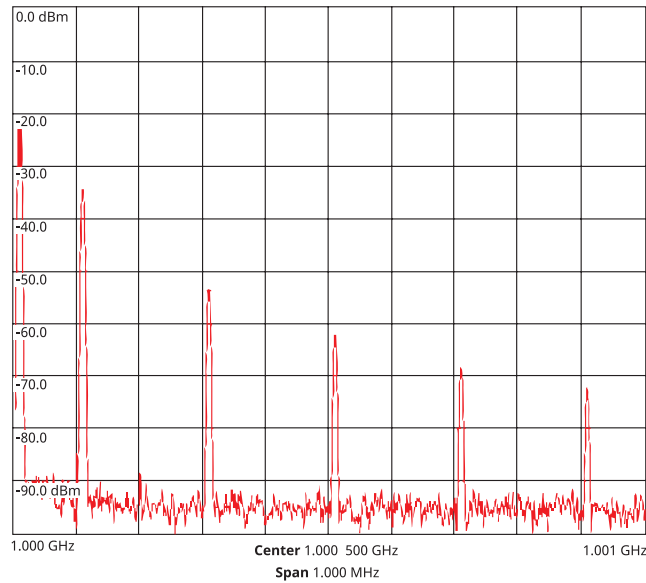

Figure 3

Spectrum Analyzers

A Spectrum Analyzer is a swept tuned analyzer is tuned by electronically sweeping its input over the desired frequency range thus, the frequency components of a signal are sampled sequentially in time (Figure 4). Using a swept tuned system enables periodic and random signals to be displayed but does not allow for transient responses.

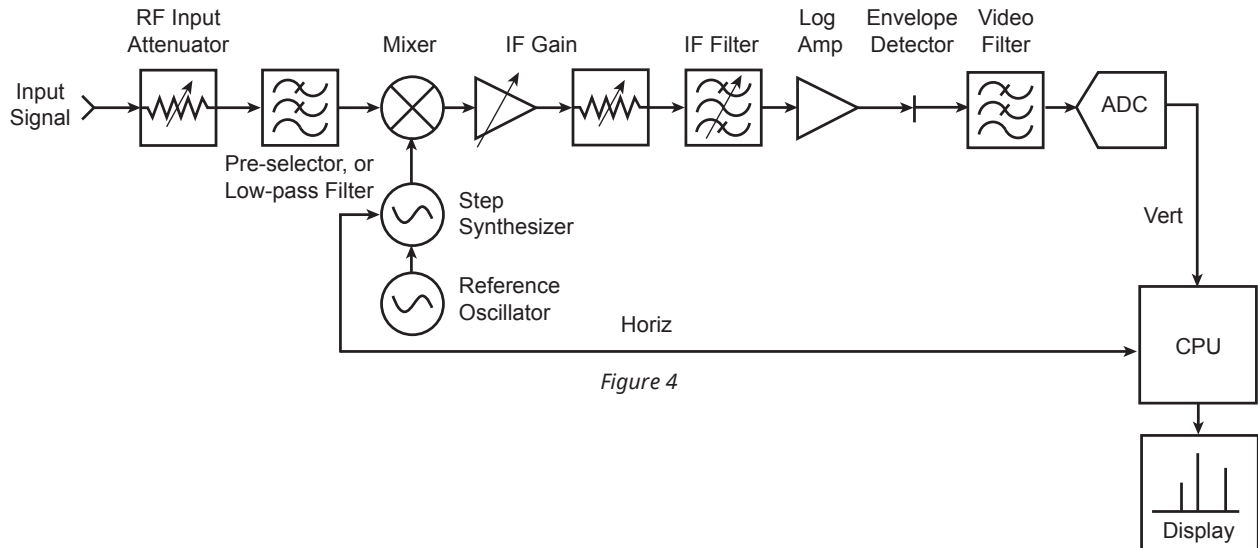
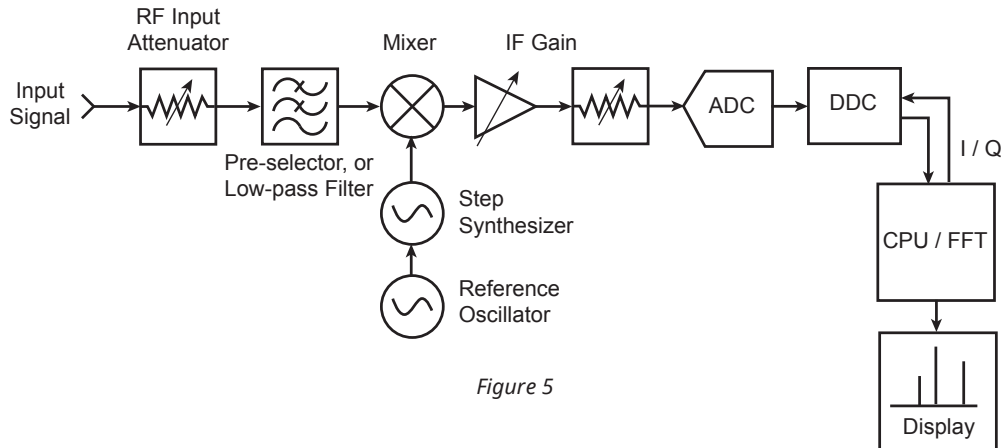

Figure 4

Signal Analyzers

Signal analyzers sample a range of frequencies simultaneously, thus preserving the time dependency and phase between signals. This technique allows both transient and periodic/random signals to be displayed (Figure 5). Signal Analyzers and Spectrum analyzers have very similar RF block diagrams, differing in frequency range (bandwidth) of the IF processing. The high bandwidth processing offers many advantages, but at increased cost.



Basic Operation

Both spectrum analyzers and signal analyzers are based on a super heterodyne receiver principle (Figure 6). The input signal, f_{IN} , is converted to an intermediate frequency, f_{IF} , via a mixer and a tunable local oscillator f_{LO} . When the frequency difference between the input signal and the local oscillator is equal to the intermediate frequency then there is a response on the display.

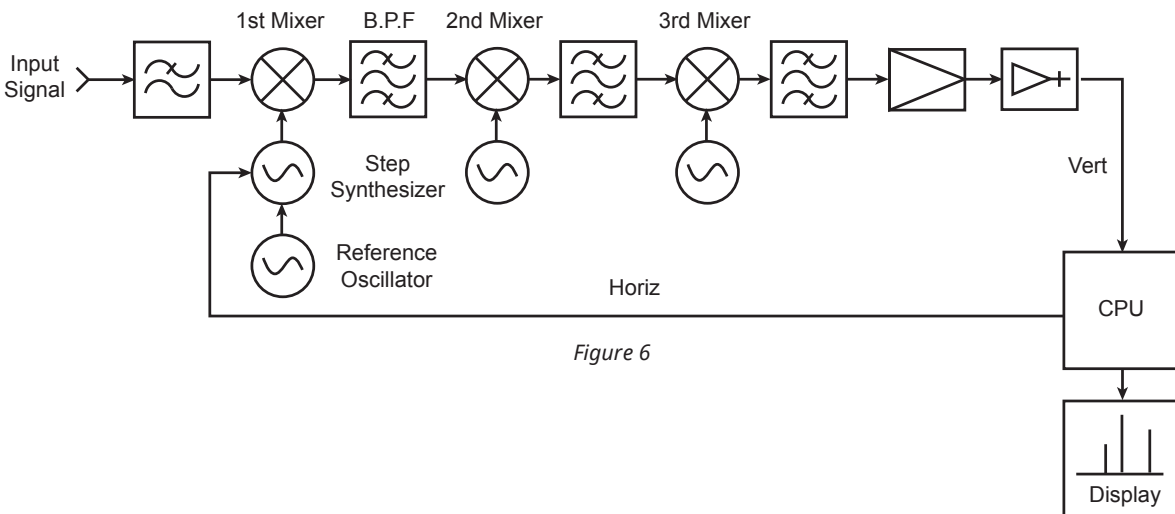

This is the basic tuning equation that determines the frequency range of a spectrum/signal analyzer. Using the super heterodyne technique enables high sensitivity through the use of intermediate frequency (IF) amplifiers and extended frequency range by using the harmonics of the local oscillator (LO). This technique is not, however, real time and sweep rates must be consistent with the IF filter bandwidth charge time.

Characteristics

Spectrum and signal analyzers have the following characteristics:

- a) Wide frequency range
- b) Amplitude and frequency calibration via internal calibration source and error correction routines
- c) Flat frequency response where amplitude is independent of frequency
- d) Good frequency stability using synthesized local oscillators and reference source
- e) Low internal distortion
- f) Good frequency resolution
- g) High amplitude sensitivity
- h) Linear and logarithmic display modes for amplitude (voltage and dB scaling)
- i) Absolute and relative measurement capabilities

Frequency Range

The lower frequency limit of a spectrum analyzer is determined by the sideband noise of the local oscillator. The local oscillator feedthrough occurs even when there is no input signal present.

The sensitivity at the lower frequency is also limited by the LO. sideband noise. Figure 7 shows typical data of average noise level vs. frequency for two IF bandwidths.

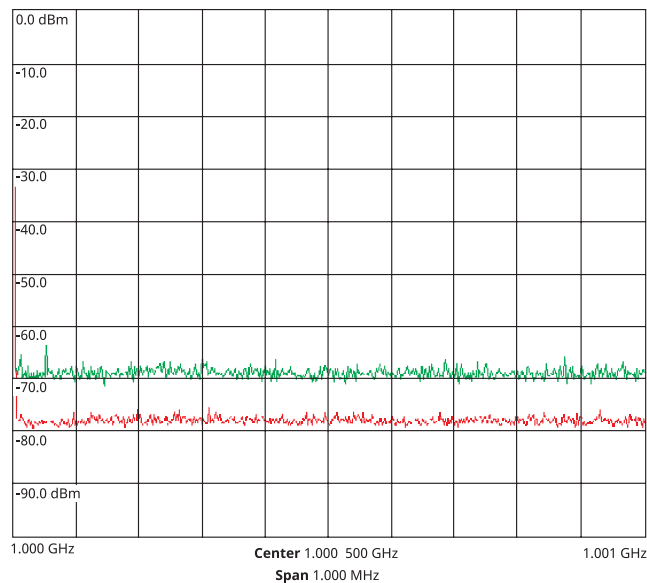

Figure 7

It should be noted however, that as the IF bandwidth is reduced so the time to sweep a given frequency range increases since the charge time of the IF filter increases. This means that the sweep time is increased to allow the IF filter to respond and therefore present an undistorted signal to the detector. These variables are generally taken into account automatically and are referred to as 'coupling'. Beyond the detector can be more filtering known as Video Bandwidth and this can also be coupled to IF bandwidth and sweep time. These functions are coupled together since they are all interdependent on each other, i.e. change one parameter setting and it affects the others.

An additional facility available on most modern analyzers is a Zero Frequency Span mode. As mentioned earlier, most analyzers are based on the super heterodyne receiver design, where the local oscillator is swept continuously. If the local oscillator is manually tuned, the spectrum analyzer becomes a fixed tuned receiver whose frequency is determined by that of the local oscillator. In this mode the analyzer will display the time domain function since the frequency component is fixed even though the scan generator is still sweeping the display i.e. the display is now amplitude vs. time (Figure 8).

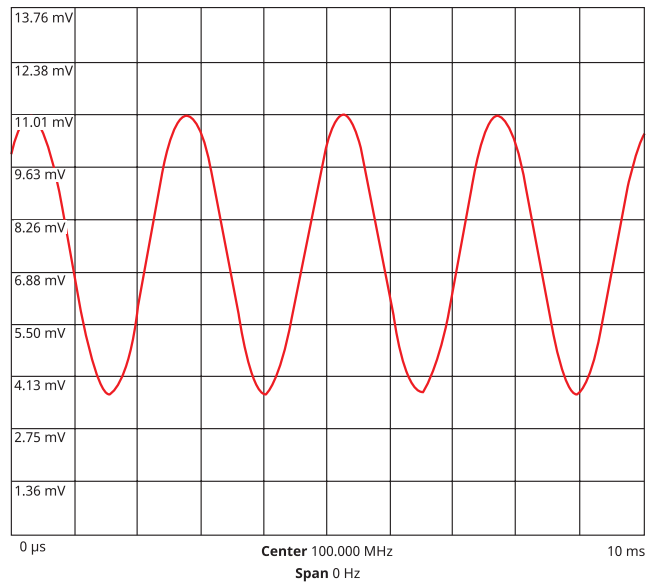

Figure 8

Frequency Resolution

The frequency resolution (typically called "resolution bandwidth") of a spectrum/signal analyzer is its ability to separate and measure two signals in close proximity. This frequency resolution is determined by three primary factors:

- a) The IF filter bandwidth used
- b) The shape of the IF filter and
- c) The sideband noise of the IF filter

The IF bandwidth is normally specified by Δf at 3 dB (Figure 9). From this it can be seen that the narrower the filter bandwidth the greater the frequency resolution. However, as mentioned earlier, as the IF band width is reduced so the charge time for the filter increases hence increasing the sweep time. As an example, narrow IF bandwidths are required to distinguish the sidebands of amplitude and frequency modulated signals (Figure 10).

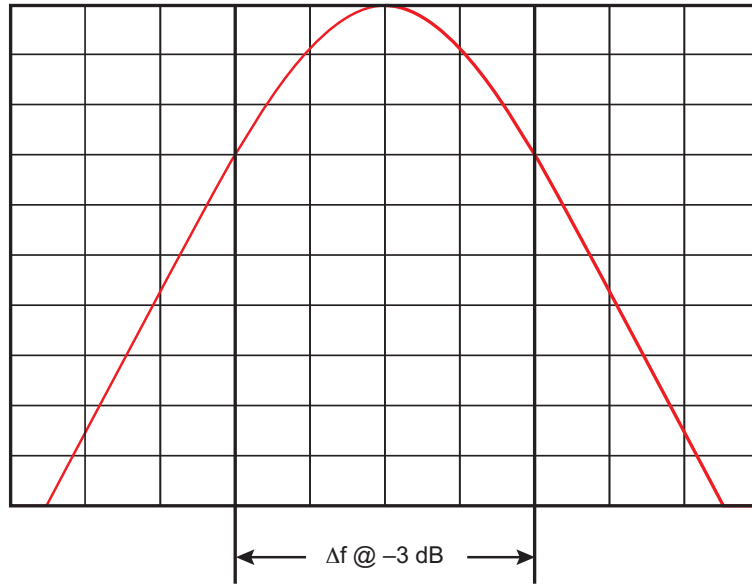

Figure 9

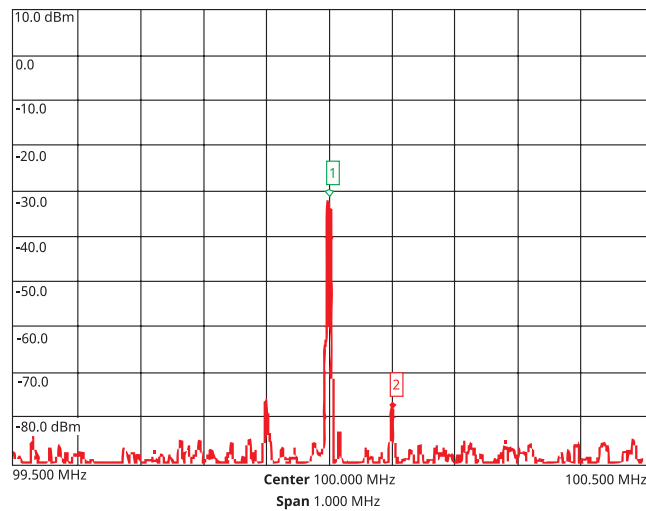

Figure 10

The IF bandwidth is normally specified by Δf at 3 dB (Figure 9). From this it can be seen that the narrower the filter bandwidth the greater the frequency resolution. However, as mentioned earlier, as the IF bandwidth is reduced so the charge time for the filter increases hence increasing the sweep time. As an example, narrow IF bandwidths are required to distinguish the sidebands of amplitude and frequency modulated signals (Figure 10).

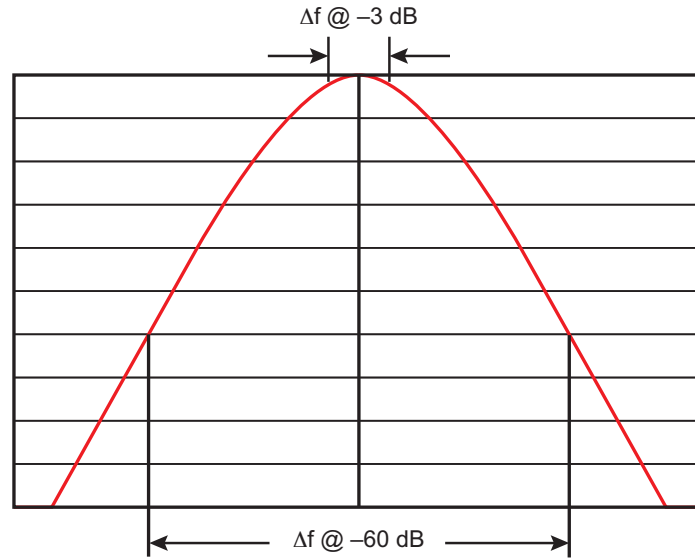

Figure 11

This skirt inclination is known as the 'shape factor' of the filter and provides a convenient guide to the filter quality. The most common type of IF filter is known as the Gaussian filter, since its shape can be derived from the Gaussian function of distribution. Typical shape factor values for Gaussian filters are 12:1/ 60 dB:3 dB, while some spectrum analyzers utilize digital filters where the shape factor can be as low as 3:1. Digital filters appear to be better in terms of frequency resolution, but they do have the drawback of sharply increasing the scan time required to sweep a given frequency range. Figure 12 shows the effects of scanning too fast for a given IF bandwidth filter. As the scan time decreases, the displayed amplitude decreases and the apparent bandwidth increases. Consequently, frequency resolution and amplitude uncertainty get worse, and some analyzers will warn you that you are now in an 'UNCAL' mode.

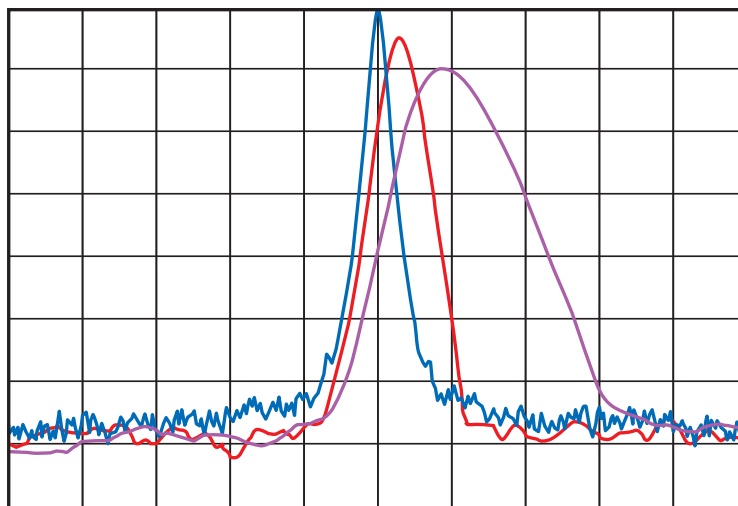

Figure 12

A spectrum analyzer's ability to resolve two closely spaced signals of unequal amplitude is not only dependent on the IF filter shape factor. Noise sidebands can reduce the resolution capabilities since they will appear above the skirt of the filter and so reduce the out of band rejection of the filter.

Sweep Speed

Spectrum analyzers, incorporating swept local oscillators have the issue of needing to manage the sweep speed to prevent uncalibrated displays. Signal analyzers do not. Blocks of spectrum are processed together in a signal analyzer. See Figure 5. The sample rate of the A to D converter determines the span of spectrum that can be processed. The span is approximately ½ the A to D sample rate. The difference in sweep speed performance between the spectrum analyzer mode and signal analyzer mode is especially visible when very narrow resolution bandwidths are used. Most modern analyzers combine swept spectrum and signal analyzer technology. The spectrum analyzer mode offers very wide span views and the signal analyzer mode offers fast spectrum displays for narrow spans. The sweep speed for signal analyzer-based spectrum displays depends on the FFT computation speed. Dedicated FFT processing circuitry can speed up spectrum display rates to support searching for intermittent signals.

$$P_N = kTB$$

Sensitivity and Noise Figure

The sensitivity of a spectrum analyzer is defined as its ability to detect signals of low amplitude. The maximum sensitivity of the analyzer is limited by the noise generated internally. This noise consists of thermal (or Johnson) and non-thermal noise. Thermal noise power is expressed by the following equation:

where

P_N = Noise power (in Watts)

k = Boltzman's constant (1.38×10^{-23} JK⁻¹)

T = Absolute temperature (Kelvin)

B = System Bandwidth (Hz)

From this equation it can be seen that the noise level is directly proportional to the system bandwidth. Therefore, by decreasing the bandwidth by an order of 10 dB the system noise floor is also decreased by 10 dB (Figure 13).

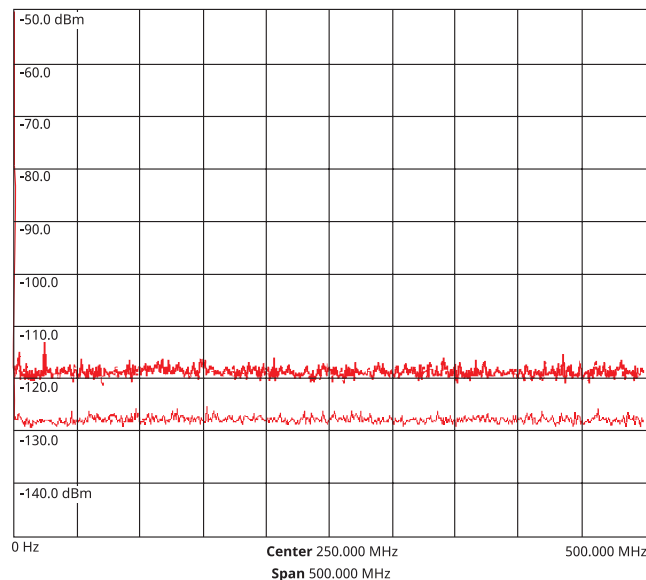

Figure 13

When comparing spectrum analyzer specifications it is important that sensitivity is compared for equal bandwidths since noise varies with bandwidth.

An alternative measure of sensitivity is the noise factor FN:

$$F_N = (S/N)_{IN} / (S/N)_{OUT}$$

where S = Signal and N = Noise

Since the noise factor is a dimensionless figure of merit we can derive the noise figure as:

$$F = 10 \log (F_N) \text{ dB}$$

Using the equation $PN = kTB$ it is possible to calculate the theoretical value of absolute sensitivity for a given bandwidth. For example, if a spectrum analyzer generates no noise products at a temperature of 17 degrees Celsius, referred to a 1Hz bandwidth, then:

$$\begin{aligned} \text{absolute sensitivity} &= 1.38 \times 10^{-23} \times 290 \\ &= 4 \times 10^{-21} \text{ W/Hz} \\ &= -174 \text{ dBm/Hz} \end{aligned}$$

To determine the noise figure of a typical spectrum analyzer where the average noise floor is specified as 120 dBm referred to a 300 Hz bandwidth:

$$\begin{aligned} -120 \text{ dBm} &= -174 \text{ dBm/Hz} + 10 \log 300 + F \text{ (dB)} \\ F \text{ (dB)} &= -120 + 174 - 24.8 \\ \text{Noise Figure} &= 29.2 \text{ dB} \end{aligned}$$

Video Filtering or Averaging

Very low level signals can be difficult to distinguish from the average internal noise level of many spectrum analyzers. Since analyzers display signal plus noise, some form of averaging or filtering is required to assist the visual detection process. As mentioned earlier, a video filter is a low pass, post detection filter that averages the internal noise of the analyzer.

Because spectrum analyzers measure signal plus noise, the minimum signal power that can be displayed is the same as the average noise power of the analyzer. From this statement it would appear that the signal would be lost in the analyzer noise but:

if signal power = average noise power
then by definition, the minimum signal power that can be displayed will be:

$$\frac{S + N}{N} = 2$$

Where

S = signal power

N = average noise power

When the signal power is added to the average noise power, the resultant signal power displayed will be 3 dB greater (Figure 14). This 3 dB difference is sufficient for low level signal identification.

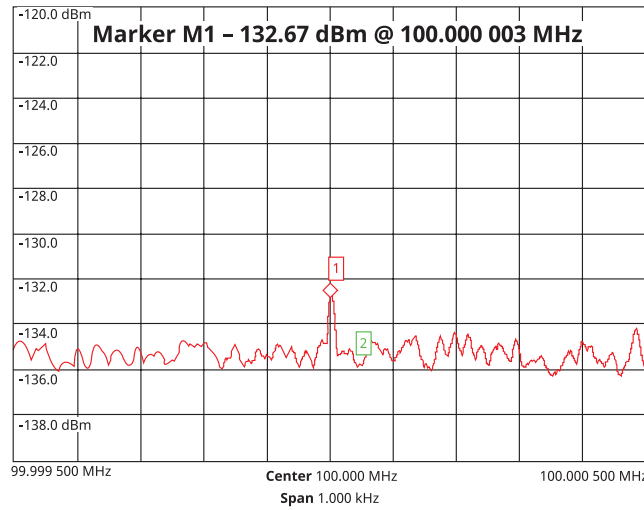

Figure 14

Signal Display Range

The signal display range of a spectrum/signal analyzer with no input attenuation is dependent on two key parameters.

- The minimum resolution bandwidth available and hence the average noise level of the analyzer and
- The maximum level delivered to the first mixer that does not introduce distortion or inflict permanent damage to the mixer performance.

Typical values for these two factors are shown in Figure 15.

As the input level to the first mixer increases so the detected output from the mixer will increase. However, since the mixer is a semiconductor diode the conversion of input level to output level is constant until saturation occurs. At this point the mixer begins to gain compress the input signal, and conversion reverts from linear to near logarithmic. This gain compression is not considered serious until it reaches 1 dB.

Input levels that result in less than 1 dB gain compression are called linear input levels (Figure 16). Above 1 dB gain compression, the conversion law no longer applies and the analyzer is considered to be operating nonlinearly and the displayed signal amplitude is not an accurate measure of the input signal.

Distortion products are produced in the analyzer whenever a signal is applied to the input. These distortion products are usually produced by the inherent nonlinearity of the mixer. By biasing the mixer at an optimum level internal distortion products can be kept to a minimum. Typically, modern spectrum analyzer mixers are specified as having an 80 dB spurious free measurement range for an input level of -30 dBm. Obviously the analyzer will be subjected to input signals greater than -30 dBm and to prevent exceeding the 1 dB compression point, an attenuator is positioned between the analyzer input and the first mixer. The attenuator automatically adjusts the input signal to provide the -30 dBm optimum level.

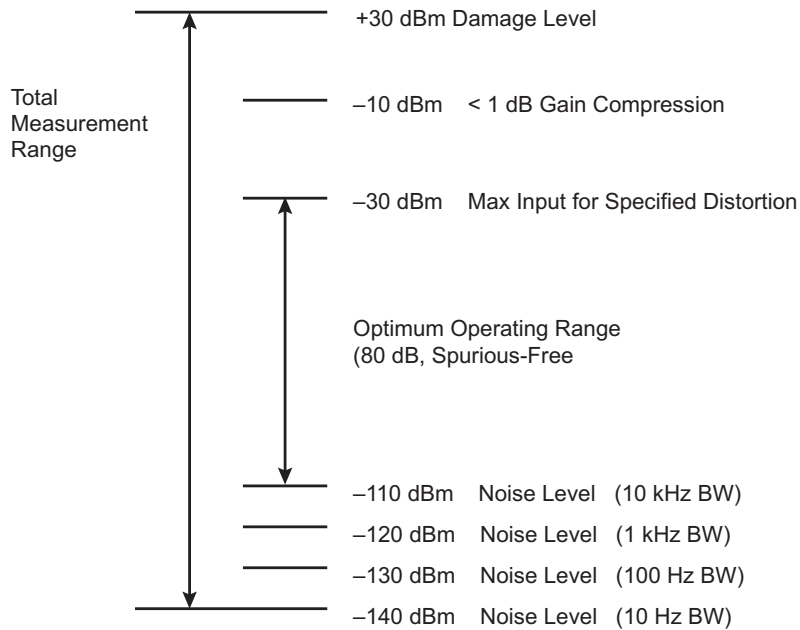

Figure 15

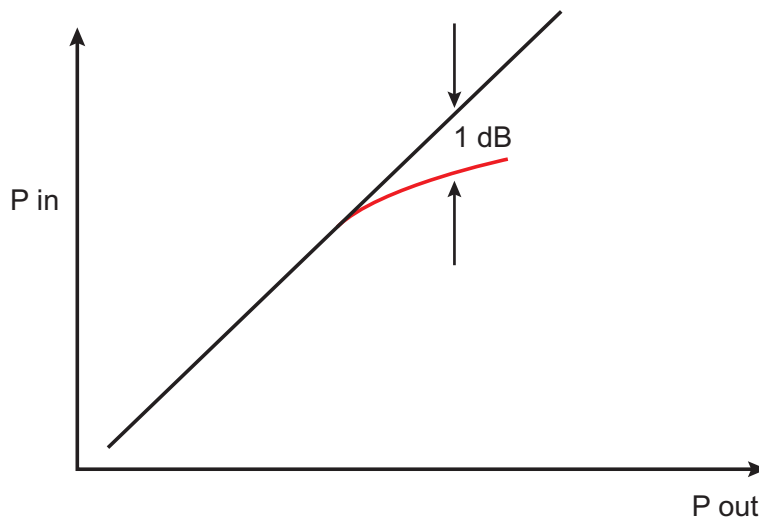

Figure 16

Dynamic Range

The dynamic range of a spectrum/signal analyzer is determined by four key factors.

- i. Average noise level.
This is the noise generated within the spectrum analyzer RF section, and is distributed equally across the entire frequency range.
- ii. Residual spurious components.
The harmonics of various signals are mixed together in complex form and converted to the IF signal components which are displayed as a response on the display. Consequently, the displayed response is present regardless of whether or not a signal is present at the input.
- iii. Distortion due to higher order harmonics.
When the input signal level is high, spurious images of the input signal harmonics are generated due to the non-linearity of the mixer conversion.
- iv. Distortion due to two signal 3rd order intermodulation products.
When two adjacent signals at high power are input to a spectrum/signal analyzer, intermodulation occurs in the mixer paths. Spurious signals, separated by the frequency difference of the input signals are generated above and below the input signals.

The level range over which measurements can be performed without interference from any of these factors is the dynamic range. This represents the analyzer's performance and is not connected with the display (or measurement) range. The four parameters that determine dynamic range can normally be found in the analyzer specifications.

For simplicity, some analyzer specifications state the dynamic range as "Y dB for an input level of X dBm". The following example shows how these parameters are related to dynamic range:

Amplitude Dynamic Range: 70 dB for a mixer input signal level of -30 dBm (Atten. = 0 dB) In order to achieve this value of dynamic range the following conditions are required:

- a) The IF bandwidth must be narrow enough such that the average noise level is better than -100 dBm.
- b) The residual spurious components must be less than -100 dBm.
- c) For an input level of 30 dBm the higher harmonic distortion must be better than -70 dB (i.e. better than -100 dBm).

Analyzer manufacturers often relate the above specifications at a particular frequency or over a range of frequencies.

Frequency Accuracy

The key parameter relating to frequency accuracy is linked to the type of reference source built into the spectrum/signal analyzer.

- Synthesized
The analyzer local oscillator is phase locked to a very stable reference source, often temperature controlled to prevent unwanted frequency drifting. In this case, a precision crystal is often used and the overall frequency accuracy and stability, both short term and long term depend on its quality. Portable analyzers, intended for outdoor use, often have GPS receivers that can significantly improve the stability of the internal local oscillator.
- Non Synthesized
The analyzer local oscillator operates as a stand-alone voltage controlled source.

Dynamic Range

Signal analyzers incorporate a wide bandwidth digitizer in the IF to capture a time block of spectrum for analysis. Frequency, time and phase relationships of signals can be analyzed within the bandwidth and time limits of the captured spectrum. Digital modulation can be characterized in many ways not possible with a swept tuned spectrum analyzer. Figure 17 compares the block diagrams for a spectrum analyzer and signal analyzer.

Figure 18 shows example time blocks of a spectrum with a variety of modulations. A signal analyzer is often used to measure the characteristics of analog and digital modulation.

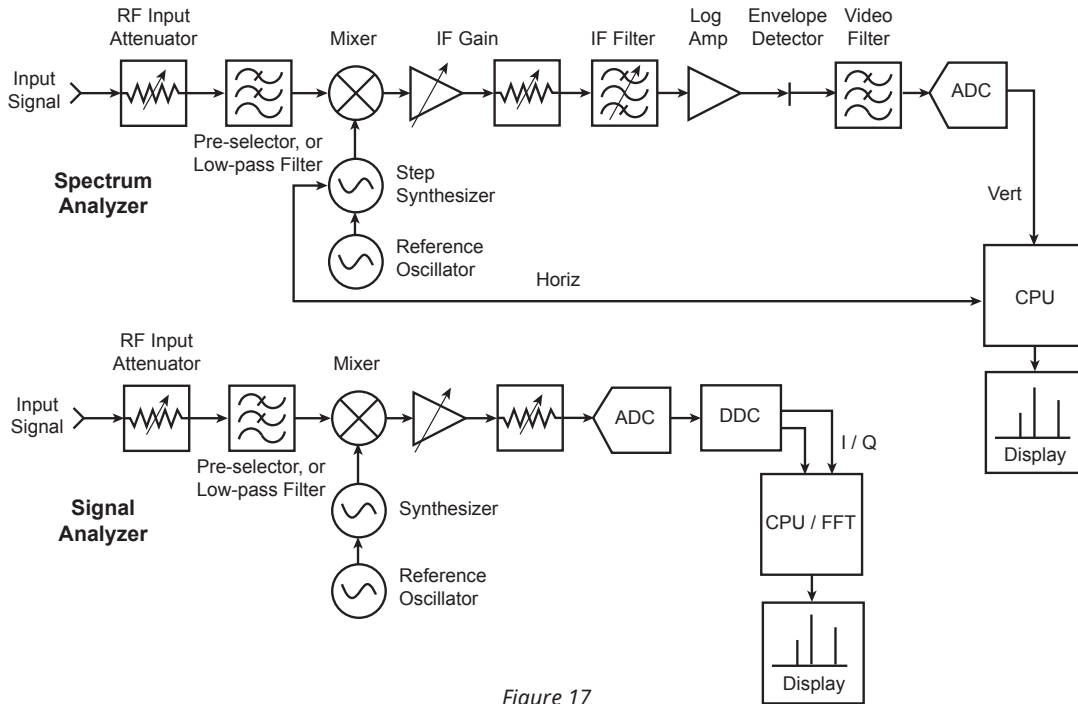

Figure 17

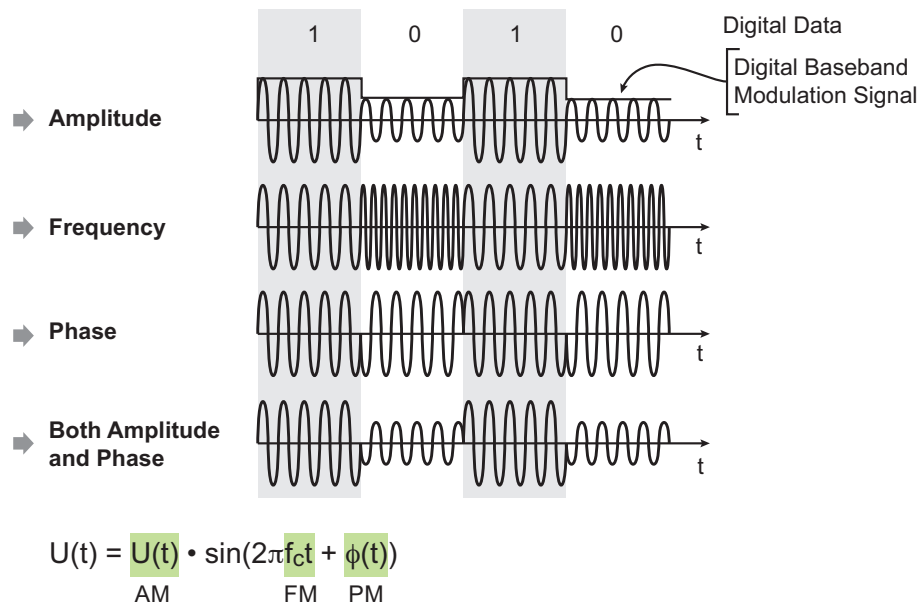

Figure 18

Figure 19 shows a signal analyzer display of QPSK modulation in polar display format. The polar display is called a constellation or vector diagram.

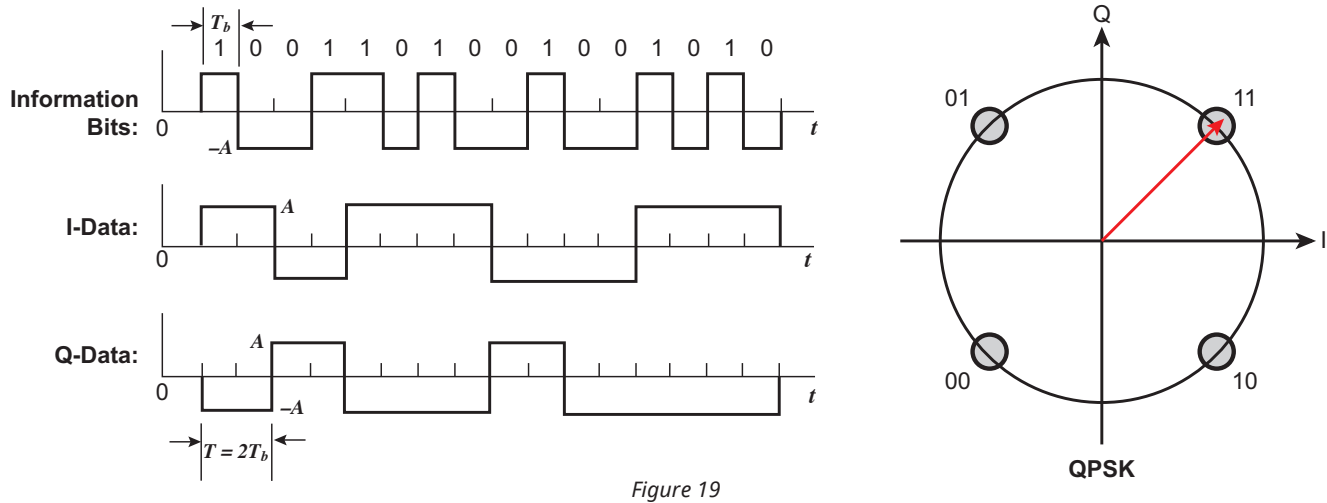

Figure 19

APPLICATIONS

As stated in the introduction, spectrum analyzers are used to display the frequency and amplitude of signals in the frequency domain. Efficient transmission of information is accomplished by a technique known as modulation. This technique transforms the information signal, usually of low frequency, to a higher carrier frequency by using a third, modulation signal. But why modulate the original signal? The two primary reasons are:

- 1) Modulation techniques allow the simultaneous transmission of two or more low frequency, or base band signals onto a higher, carrier frequency and
- 2) High frequency antenna are small in physical size and more electrically efficient.

In this section we will consider three common modulation formats:

- Amplitude Modulation or AM.
- Frequency Modulation or FM.
- Pulse Modulation or PM.

Each modulation technique places emphasis on a particular area of the analyzer's specification.

Amplitude Modulation

As the name suggests, amplitude modulation is where the carrier signal amplitude is varied by an amount proportional to the amplitude of the signal wave and at the frequency of the modulation signal. The amplitude variation about the carrier is termed the modulation factor 'm'. This is usually expressed as a percentage called the percent modulation, %M.

The complex expression for an AM carrier shows that there are three signal elements.

- a) The unmodulated carrier.
- b) The upper sideband whose frequency is the sum of the carrier and the modulation frequency.
- c) The lower sideband whose frequency is the difference between the carrier and the modulation frequency.

The spectrum analyzer display enables accurate measurement of three key AM parameters.

- Modulation Factor m
- Modulation Frequency f_m
- Modulation Distortion

Figure 20 shows the time domain display of a typical AM signal. From this the modulation factor, m , can be expressed as follows:

$$m = \frac{E_{\max} - E_c}{E_c} \quad \text{Equation 1}$$

Since the modulation is symmetrical:

$$E_{\max} - E_c = E_c - E_{\min} \quad \text{Equation 2}$$

$$E_c = \frac{E_{\max} + E_{\min}}{2} \quad \text{Equation 3}$$

$$m = \frac{E_{\max} - E_{\min}}{E_{\max} + E_{\min}} \quad \text{Equation 4}$$

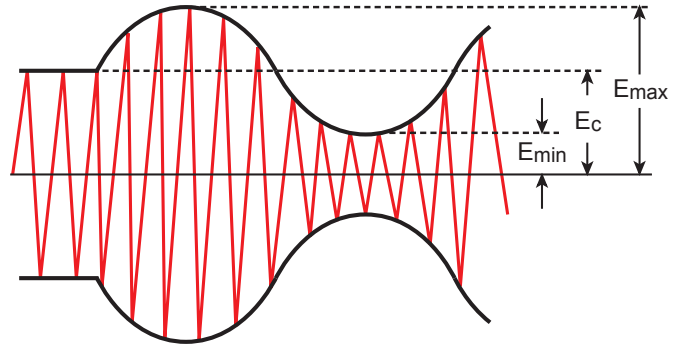

Figure 20

Equation 4 is true for sinusoidal modulation. If we view the AM signal on a spectrum analyzer in linear (voltage) mode we obtain Figure 21.

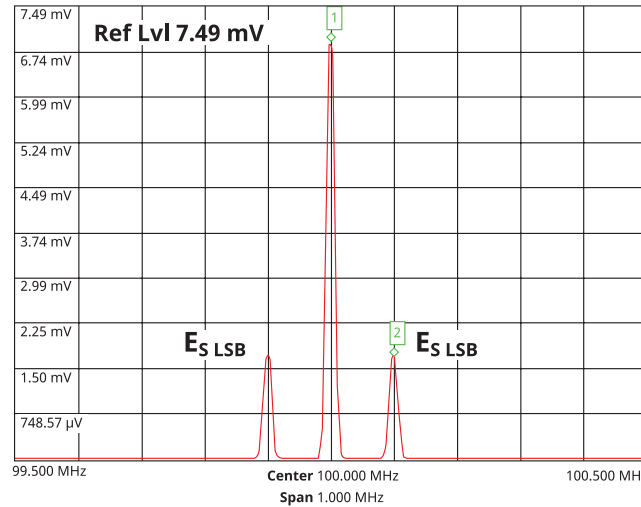

Figure 21

From this the percentage modulation, $\%M$, can be calculated as follows:

$$\%M = \frac{(E_{S\text{ LSB}} + E_{S\text{ USB}})}{E_c} \times 100 \quad \text{Equation 5}$$

where E_s = Amplitude of the sideband (volts)
 E_c = Amplitude of the carrier (volts).

For low levels of modulation it is more convenient to use the analyzers logarithmic display as in Figure 22.

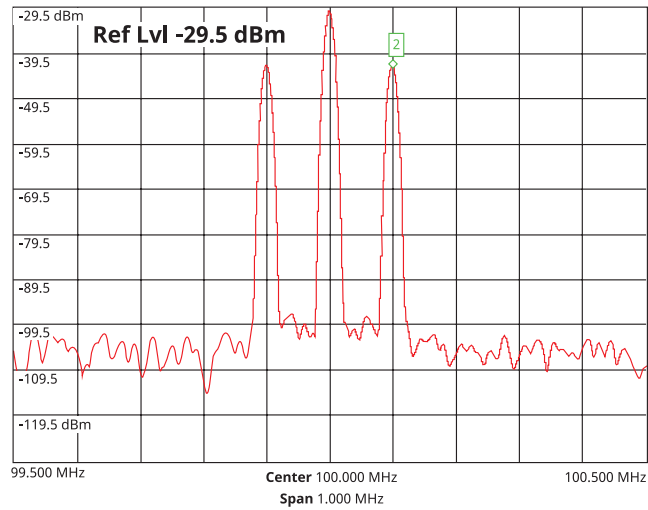

Figure 22

The relationship between the sideband level and the percentage modulation is shown in Table 1.

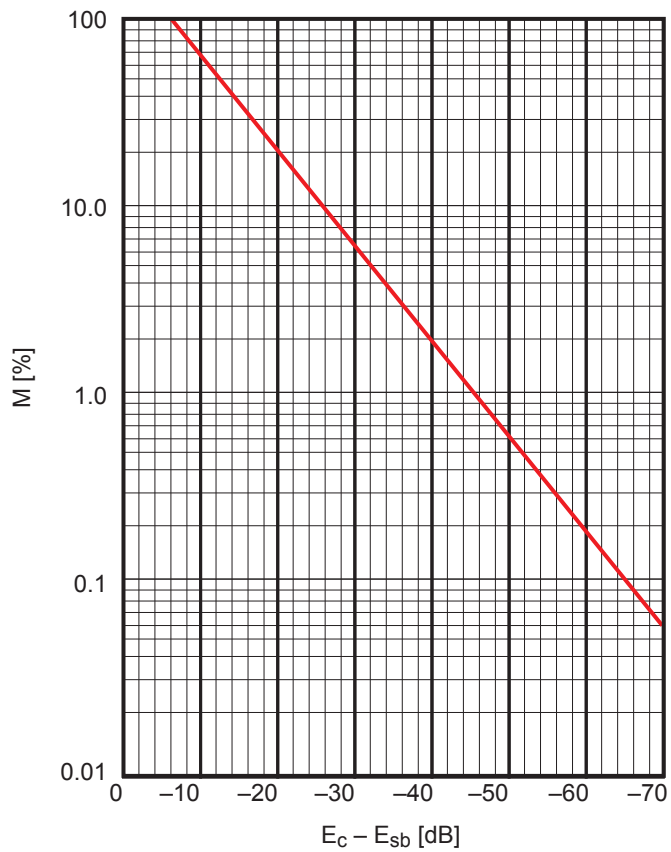

Figure 23

As an example, consider a case in which the carrier frequency $F_c = 1000$ MHz, and the modulation frequency $f_m = 1$ kHz.

Figure 23 shows the result of observation using an oscilloscope. From the envelope, $\%M = 50\%$ ($m = 0.5$).

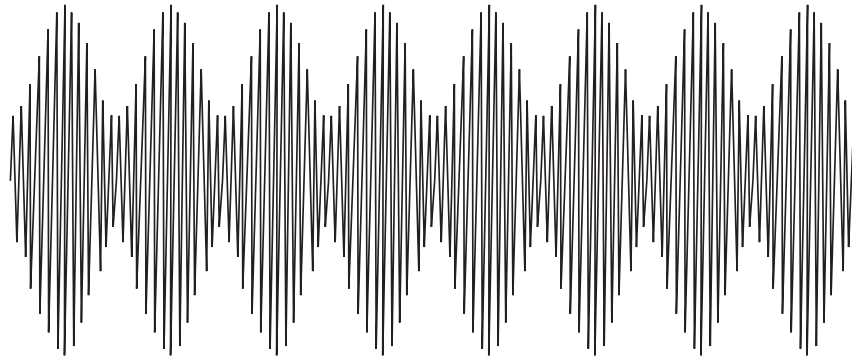

Figure 24

Figure 24 shows the same signal displayed on the linear scale (voltage) of a spectrum analyzer. From Equation 5.

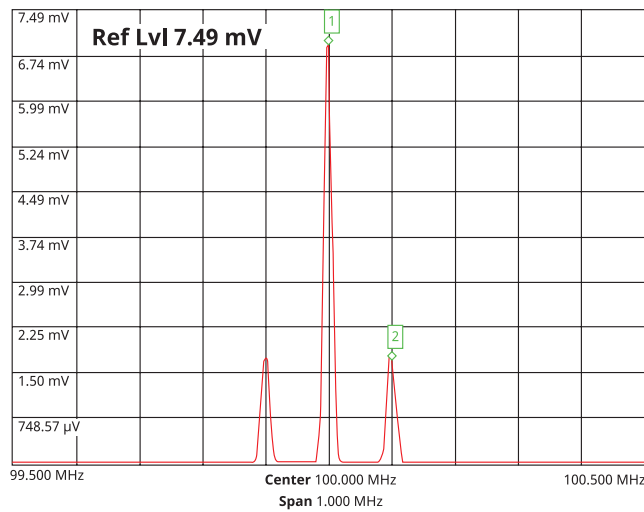

Figure 25

$$\%M = \frac{1.76 \text{ mV} + 1.76 \text{ mV}}{6.97 \text{ mV}} \times 100$$

$$\%M = 50\%$$

If $m = 0.05$ (%M = 5%), then for the same conditions the sideband level will be 0.165 mV for a carrier level of 6.6 mV. Clearly for low modulation factors the logarithmic display is better suited (Figure 25).

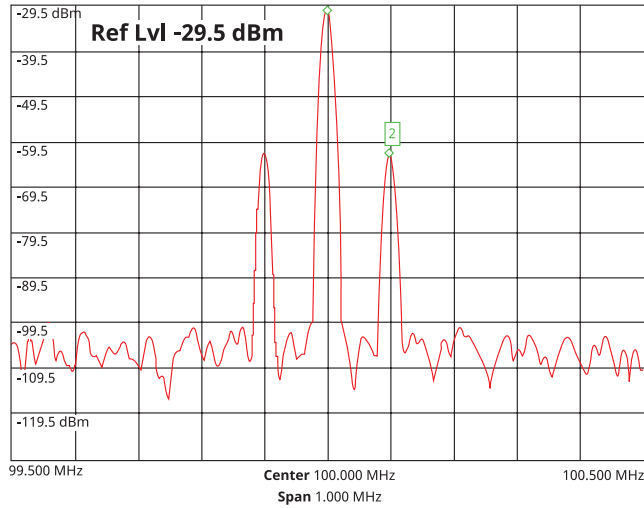

Figure 26

Modulation Frequency fm

As stated earlier, for amplitude modulation the upper and lower sidebands displayed on a spectrum analyzer will be separated from the carrier by a frequency equal to the modulation frequency (Figure 26). This frequency domain display assumes that the IF bandwidth is narrow enough to resolve the spectral components of the modulated carrier. However, a common modulation test tone of 400 Hz will be difficult to measure if the analyzer has a minimum 1 kHz resolution bandwidth. More difficulties arise if the phase noise of the carrier masks low frequency modulation sidebands with small modulation factors.

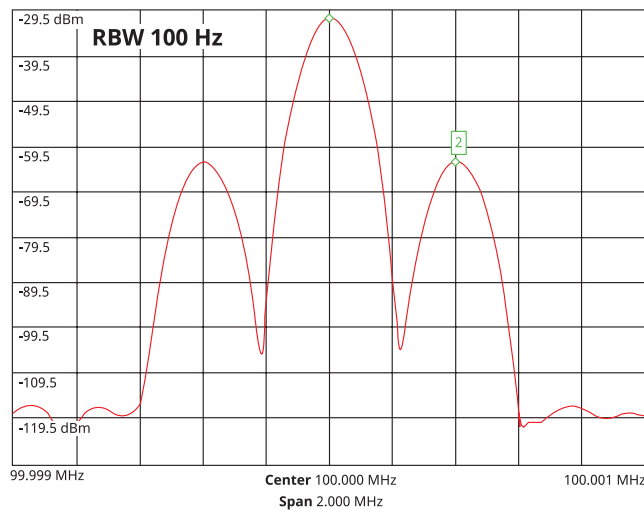

Figure 27

If the modulation factor is high enough, we can use the spectrum analyzer as a fixed tuned receiver as follows:

- a) Set the carrier to the center of the display
- b) Ensure that the resolution bandwidth and the video bandwidth are sufficiently wide enough to encompass the modulation sidebands without attenuation
- c) Select zero span and adjust the reference level so that the peak of the signal is near to the top of the screen
- d) Select linear display mode, video triggering and adjust the sweep time to display several cycles of the demodulated waveform

From this display we can measure the modulation factor, m , and the modulating frequency using the analyzers delta marker function (Figure 27).

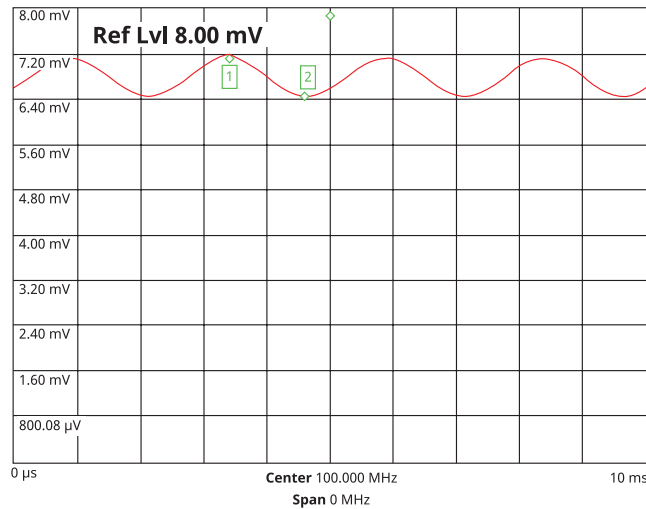

Figure 28

Note: Since this is a relative measurement, as we adjust the reference level of the analyzer, the absolute values of E_{max} and E_{min} change but the ratio remains constant. Using the delta marker function will yield the ratio E so by modifying the equation for m we can use this ratio directly.

$$m = \frac{(1 - (E_{min} / E_{max}))}{(1 + (E_{min} / E_{max}))}$$

Modulation Distortion

Distortion of an amplitude modulated carrier wave is commonly due to either or both of the following:

- a) Second and subsequent harmonics of the modulation signal and,
- b) Over modulation of the carrier wave. i.e. $%M > 100%$.

Measuring modulation distortion can be performed directly from the frequency domain display of a spectrum analyzer. Consider Figure 28.

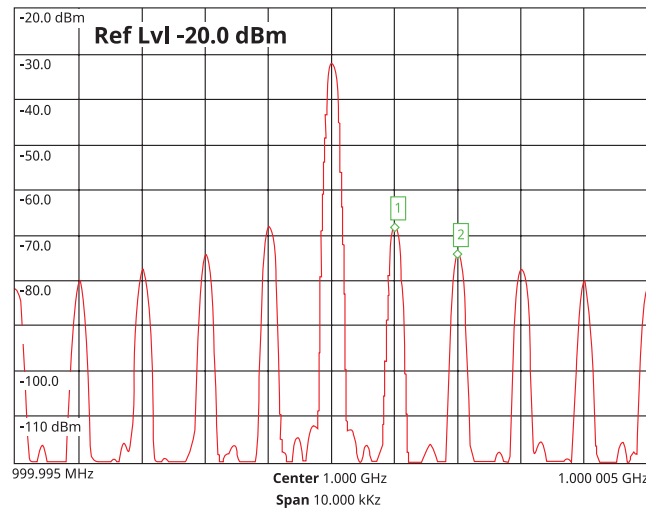

Figure 29

The upper and lower sidebands adjacent to the carrier are the modulation components but the second and subsequent pairs of sidebands are due to the harmonics of the modulation signal. Using a logarithmic scale, the level difference between the first and second sidebands gives the 2nd harmonic distortion for the waveform. In the case of Figure 28 this is 6 dB. This same procedure can be used for 3rd harmonic distortion also.

Now consider Figure 29. This shows an over-modulated 100 MHz carrier with $f_m = 1$ kHz. From the time domain display (Figure 30) we can see that the carrier is cut off when the modulation frequency is at a minimum. From the corresponding frequency domain display, the first sideband pair are 6 dB lower than the carrier hence $\%M = 100\%$ but note also the severe harmonic distortion products.

These distortion products effectively increase the occupied bandwidth unnecessarily.

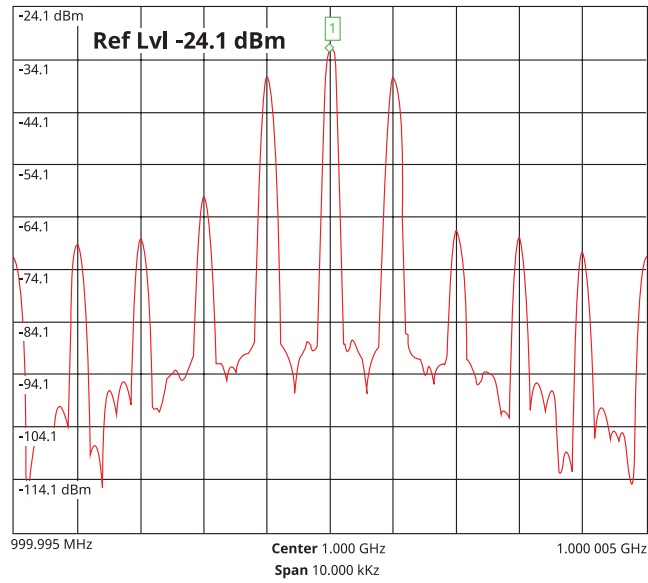

Figure 30

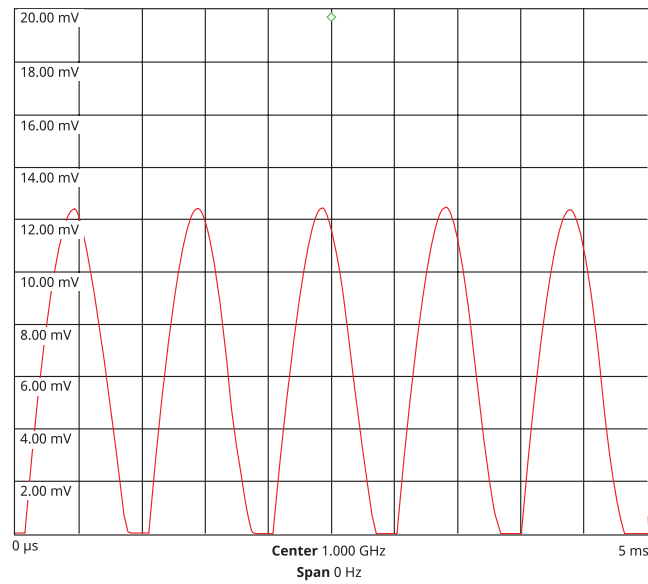

Figure 31

By definition, the information transmitted by amplitude modulation is carried not by the carrier but via the sidebands. Thus varying the composite AM waveform varies only the sideband amplitude. If the carrier component is suppressed, then the overall power saving improves the efficiency of the transmission system. This type of modulation is called Double Sideband Suppressed Carrier or DSBSC. In order to recover the modulation signal the carrier must be reinserted at the receiver.

Furthermore, we could also remove one of the sidebands since the same information is carried by both. This would result in a further power saving and a reduction in the occupied bandwidth of the signal. This type of modulation is called Single Sideband Suppressed Carrier but is usually just called Single Sideband (SSB).

Frequency Modulation

Frequency modulation, FM, is a form of modulation in which the frequency of a carrier wave is varied above and below its unmodulated value by an amount proportional to the amplitude of a signal wave and at the frequency of the modulating signal. In this case the carrier amplitude remains constant. Frequency modulation differs from amplitude modulation in a number of ways.

- Since the amplitude of the modulated carrier remains constant, regardless of the modulation frequency and amplitude, no power is added to or removed from the carrier wave of an FM signal.
- Frequency modulation of a sinusoidal carrier with a second varying sinusoid yields an infinite number of sidebands separated by the modulation frequency f_m .
- The peak-to-peak amplitude of the signal wave determines the maximum frequency deviation of the modulated carrier.

The Bessel function curves of Figure 31 show the relationship between the carrier and sideband amplitudes of a frequency modulated wave as a function of the modulation index m .

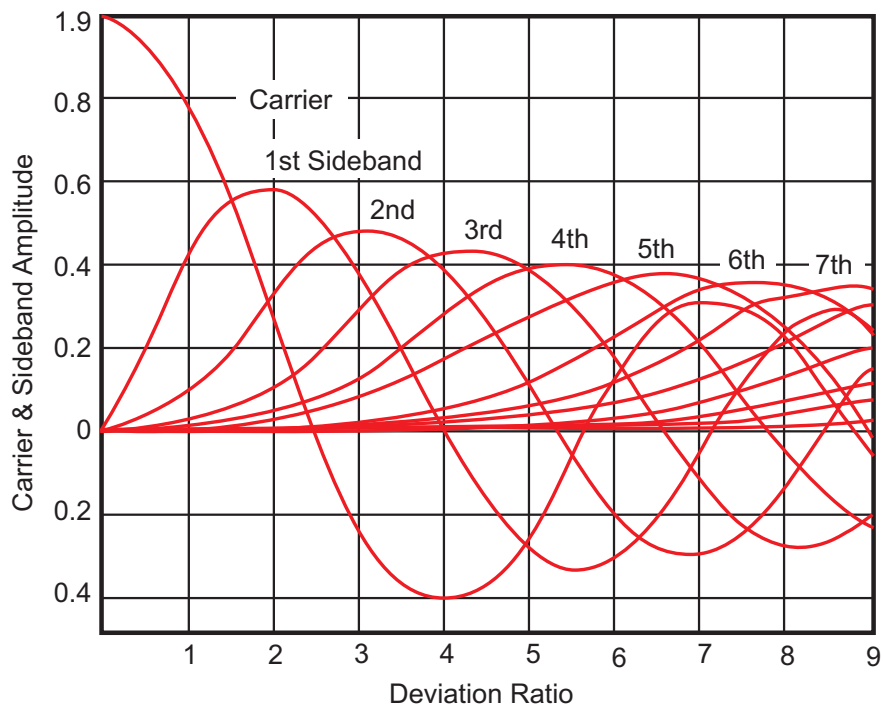

Figure 32

Note that the carrier component J_0 and the various sidebands J_N go to zero amplitude for specific values of m . From these curves we can determine the amplitude of the carrier and the sideband components in relation to the unmodulated carrier. For example, we find for a modulation index of $m = 3$ the following amplitudes:

- Carrier $J_0 = 0.26$
- First order sideband $J_1 = 0.34$
- Second order sideband $J_2 = 0.49$
- Third order sideband $J_3 = 0.31$

The sign of the values we get from the curves is not significant since a spectrum analyzer displays only absolute amplitudes. The exact values for the modulation index corresponding to each of the carrier zeros are listed in the Appendix C.

Bandwidth of FM Signals

In practice, the spectrum of an FM signal is not infinite. The sideband amplitudes become negligible beyond a certain frequency offset from the carrier, depending on the magnitude of m . We can determine the bandwidth required for low distortion transmission by counting the number of significant sidebands. (Significant sidebands usually refers to those sidebands that have a voltage at least one percent (40 dB) of that of the unmodulated carrier).

Figures 32 and 33 show the analyzer displays of two FM signals, one with $m = 0.2$, the other with $m = 95$. Two important facts emerge from these figures:

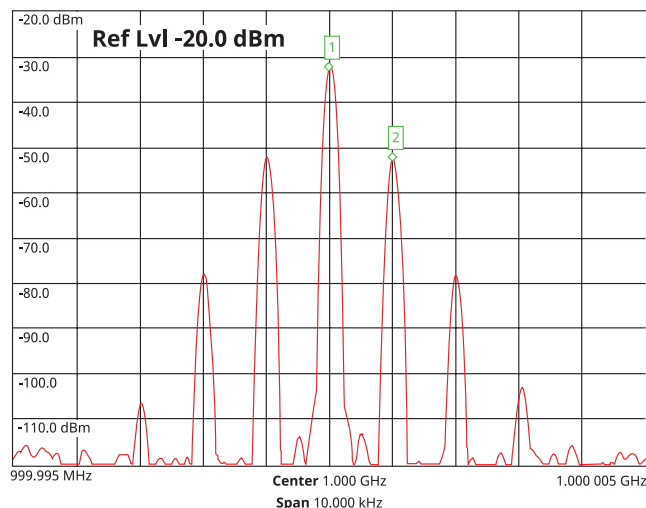

Figure 33

- 1) For very low modulation indices ($m < 0.2$), we get only one significant pair of sidebands. The required transmission bandwidth in this case is twice FM, as for AM.
- 2) For very high modulation indices ($m > 100$), the transmission bandwidth is twice Δf_{pk} . For values of m between these margins we have to count the significant sidebands.

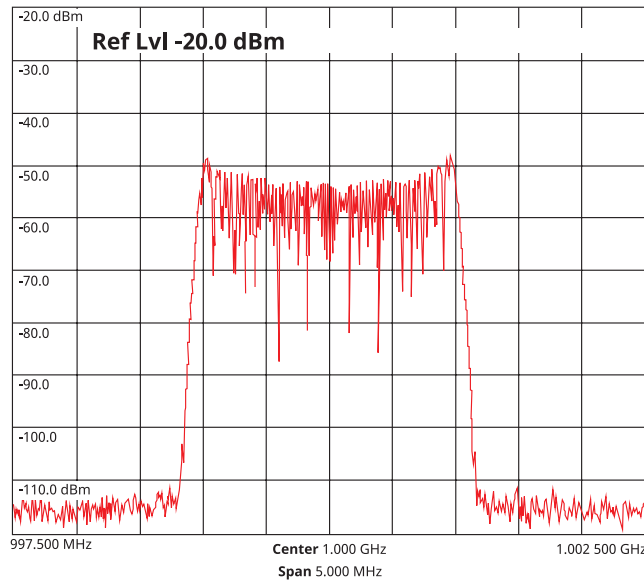

Figure 34

For voice communication a higher degree of distortion can be tolerated; that is, we can ignore all side bands with less than 10% of the carrier voltage (20 dB). We can calculate the necessary bandwidth B using the approximation:

$$B = 2\Delta F_{pk} + 2F_m$$

$$\Delta F_{pk} = m \times f_m \text{ maximum frequency deviation}$$

$$\text{or } B = 2F_m (1 + m)$$

So far our discussion of FM sidebands and bandwidth has been based on having a single sine wave as the modulating signal. Extending this to complex and more realistic modulating signals is difficult. We can extend this to look at an example of single tone modulation for some useful information.

An FM broadcast station has a maximum frequency deviation (determined by the maximum amplitude of the modulation signal) of $\Delta f = 80$ kHz. The highest modulation frequency f_m is 15 kHz. This yields a modulation index of $m = 5.33$ and the resulting signal has eight significant sideband pairs. Thus the required bandwidth can be calculated as 190 kHz. For modulation frequencies below 15 kHz (with the same amplitude), the modulation index increases above five and the bandwidth eventually approaches $2\Delta f$ kHz = 160 for very low modulation frequencies

Therefore, we can calculate the required transmission bandwidth using the highest modulation frequency and the maximum frequency deviation Δf_{pk} .

FM Measurements with a Spectrum Analyzer

The spectrum analyzer is a very useful tool for measuring Δf and m and for making fast and accurate adjustments of FM transmitters. It is also frequently used for calibrating frequency deviation meters.

A signal generator or transmitter is adjusted to a precise frequency deviation with the aid of a spectrum analyzer using one of the carrier zeros and selecting the appropriate modulating frequency. In Figure 34, a modulation frequency of 1 kHz and a modulation index of 2.405 (first carrier null) necessitate a carrier peak frequency deviation of exactly 2.405 kHz. Since we can accurately set the modulation frequency using the spectrum analyzer or, if need be, a frequency counter and since the modulation index is also known accurately, the frequency deviation thus generated will be equally accurate.

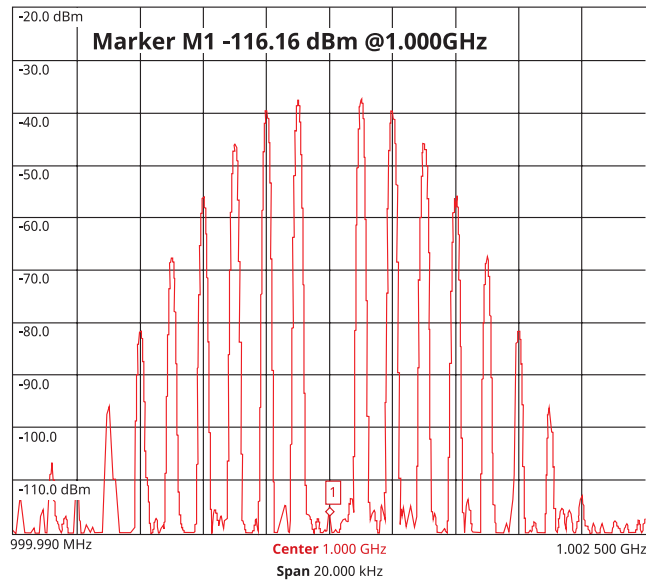

Figure 35

Table 2 gives the modulation frequencies and common values of deviation for the various orders of carrier zeros.

Order of Carrier Zero	Mod Index	Commonly Used Values of FM Peak Deviation								
		7.5 kHz	10 kHz	15 kHz	25 kHz	30 kHz	50 kHz	75 kHz	100 kHz	150 kHz
1	2.405	3.12	4.16	6.25	10.42	12.50	20.83	31.25	41.67	62.50
2	5.52	1.36	1.18	2.72	4.53	5.43	9.08	13.59	18.12	27.17
3	8.65	0.87	1.16	1.73	2.89	3.47	5.78	8.67	11.56	17.34
4	11.79	0.66	0.85	1.27	2.12	2.54	4.24	6.36	8.48	12.72
5	14.93	0.50	0.67	1.00	1.67	2.01	3.35	5.02	6.70	10.05
6	18.07	0.42	0.55	0.83	1.88	1.66	2.77	4.15	5.53	8.30

Table 2

The spectrum analyzer can also be used to monitor FM transmitters (for example, broadcast or communications stations) for occupied bandwidth. Here the statistical nature of the modulation must be considered. The signal must be observed long enough to make capturing peak frequency deviation probable. The MAXHOLD capability, available on spectrum analyzers with digitized traces, is then used to acquire the signal. To better keep track of what is happening, you can often take advantage of the fact that most analyzers of this type have two or more trace memories.

Select the MAX HOLD mode for one trace while the other trace is live. See Figure 35.

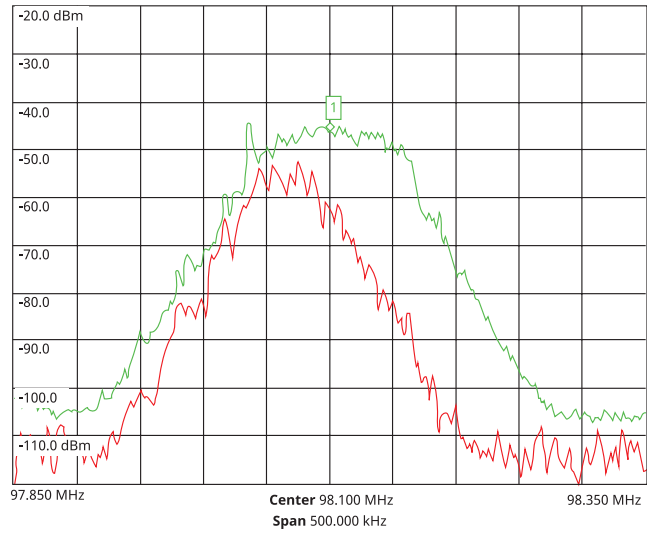

Figure 36

As with AM, it is possible to recover the modulating signal. The analyzer is used as a manually tuned receiver (zero span) with a wide IF bandwidth. However, in contrast to AM, the signal is not tuned into the passband center but to one slope of the filter curve as illustrated in Figure 36. Here the frequency variations of the FM signal are converted into amplitude variation (FM to AM conversion). This method is called slope detection and is not widely used on modern spectrum analyzers since many of them have dedicated FM demodulators.

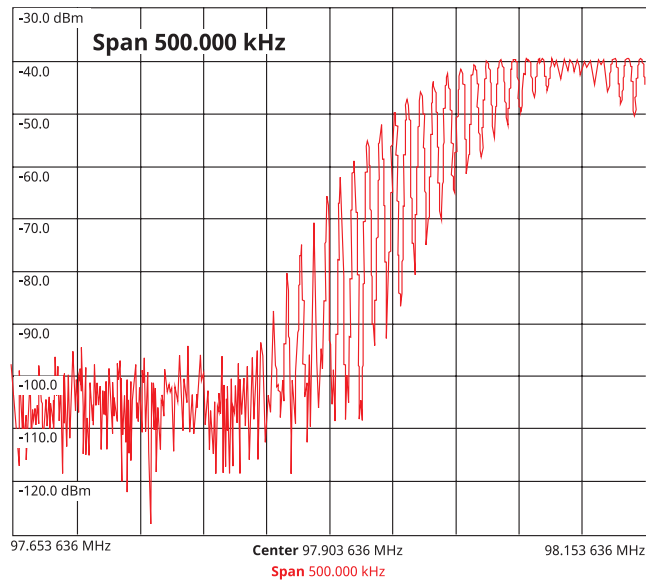

Figure 37

The resultant AM signal is then detected with the envelope detector. The detector output is displayed in the time domain and is also available at the video output for application to headphones or a speaker.

A disadvantage of this method is that the detector also responds to amplitude variations of the signal. The majority of Anritsu spectrum analyzers can provide FM and AM demodulators. In addition, Anritsu handheld spectrum analyzers include SSB signal demodulation with a beat frequency oscillator (BFO) to reinsert the suppressed carrier.

AM Plus FM (Incidental FM)

Although AM and FM are different methods of modulation, they have one property in common; they always produce a symmetrical sideband spectrum.

Figure 37 illustrates a modulated carrier with asymmetrical sidebands. One way this could occur is if both AM and FM or AM and phase modulation exist simultaneously at the same modulating frequency. This indicates that the phase relationship between carrier and sidebands are different for the AM and the angular modulation. Since the sideband components of both modulation types add together vectorally, the resultant amplitude of one sideband may be reduced while the amplitude of the other would be increased accordingly. The spectrum analyzer does not retain any phase information and so in each case displays the absolute magnitude of the result.

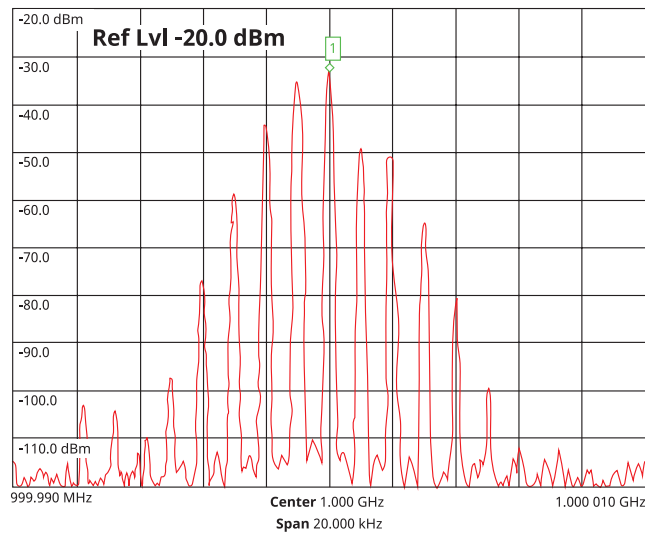

Figure 38

PULSE AND PULSE MODULATED SIGNALS

When a perfectly rectangular pulse waveform is transformed from the time domain to the frequency domain (Figure 38), the resulting envelope follows a function of the form:

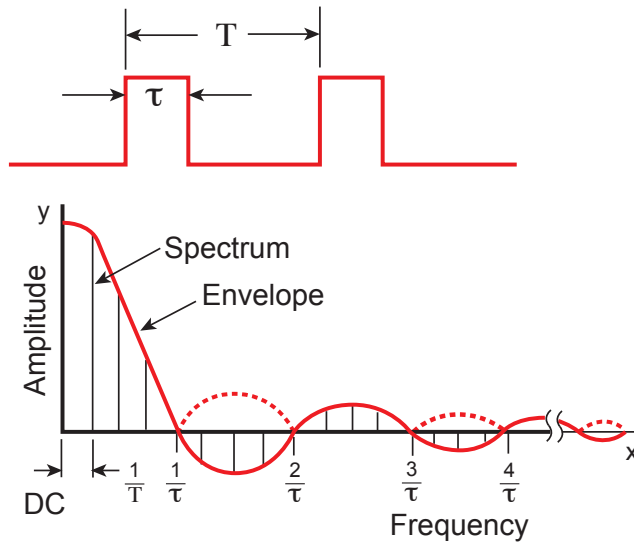

Figure 39

Figure 39 shows the spectral plot resulting from rectangular amplitude pulse modulation of a carrier. The individual lines represent the modulation product of the carrier and the modulation pulse repetition frequency with its harmonics. Thus, the lines will be spaced in frequency by whatever the pulse repetition frequency might happen to be.

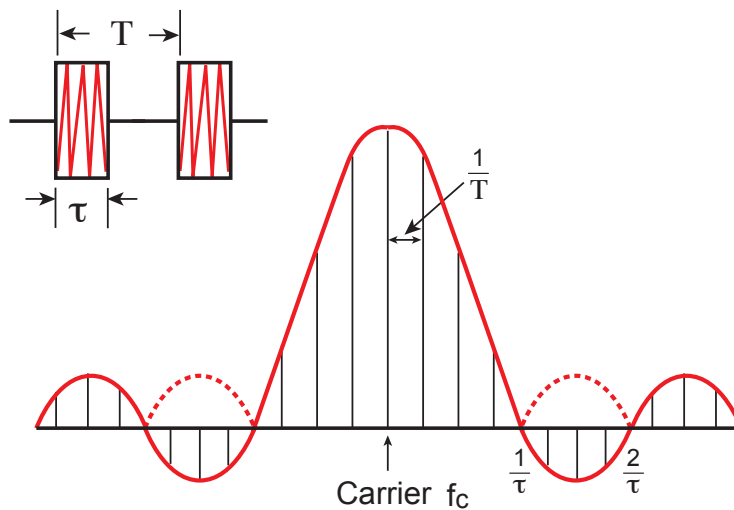

Figure 40

We know from single tone AM how the sidebands are produced above and below the carrier frequency. The idea is the same for a pulse, except that the pulse is made up of many tones, thereby producing multiple sidebands which are commonly referred to as spectral lines on the analyzer display. In fact, there will be twice as many sidebands (or spectral lines) as there are harmonics contained in the modulating pulse.

The main lobe (in the center) and the side lobes are shown as groups of spectral lines extending above and below the baseline. For perfectly rectangular pulses and other functions whose derivatives are not continued at some point, the number of side lobes is infinite.

The main lobe contains the carrier frequency and is represented by the longest spectral line in the center. The amplitude of the spectral lines forming the lobes varies as a function of frequency.

Notice in Figure 39 how the spectral lines extend below the baseline as well as above. This corresponds to the harmonics in the modulating pulse having a phase relationship of 180° with respect to the fundamental of the modulating waveform. Since the spectrum analyzer can only detect amplitude and not phase, it will invert the negative going lines and display all amplitudes above the baseline.

Because a pulsed RF signal has unique properties, care must be taken to interpret the display on a spectrum analyzer correctly. The response that the spectrum analyzer (or any swept receiver) can have to a periodically pulsed RF signal can be of two kinds, resulting in displays which are similar but of completely different significance. One response is called a line spectrum and the other is a pulse spectrum. We must keep in mind that these are both responses to the same periodically pulsed RF input signal and that line and pulse spectrum refer only to the response displayed on the spectrum analyzer.

Pulse Response

If we increase the IF bandwidth in our example to 1 kHz, we get the display shown in Figure 40. Notice that the analyzer has lost the ability to resolve the spectral lines since $B = PRF$. The lines now displayed are generated in the time domain by the single pulses of the signal. We also see that the displayed amplitude of the spectrum envelope has increased. This is due to the fact that the IF filter is now sampling a broader section of the spectrum, thus collecting the power of several spectral lines.

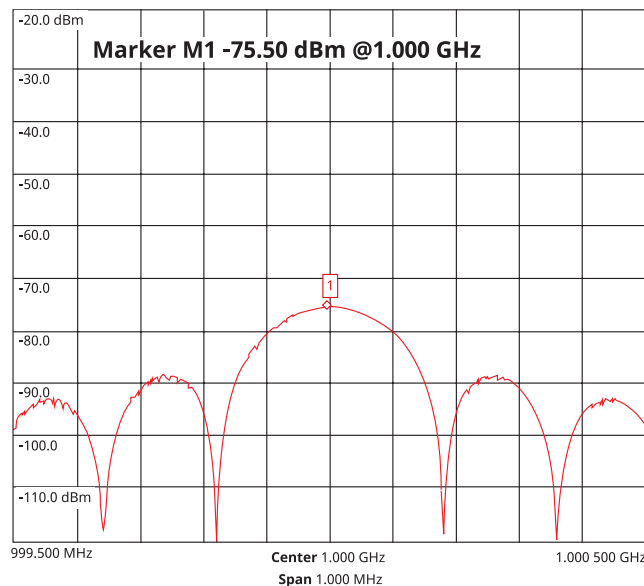

Figure 41

A pulse repetition rate equal to the resolution bandwidth is the demarcation line between a true Fourier series spectrum, where each line is a response representing the energy contained in that harmonic and a pulse of the Fourier transform response.

Pulse Spectrum

A pulse spectrum occurs when the bandwidth B of the spectrum analyzer is equal to or greater than the PRF. The spectrum analyzer in this case cannot resolve the actual individual Fourier frequency domain components, since several lines are within its bandwidth. However, if the bandwidth is narrow compared to the spectrum envelope, then the envelope can be resolved. The resultant display is not a true frequency domain display, but a combination of time and frequency domains. It is a time domain display of the pulse lines, since each line is displayed when a pulse occurs, regardless of the frequency within the pulse spectrum to which the analyzer is tuned at that moment. It is a frequency domain display of the spectrum envelope.

MEASUREMENT EXAMPLES

The measurements described in this section are generally available 'one button' functions on modern, high performance spectrum analyzers as but may not appear on all the available models.

Intermodulation Distortion

Signals generated by intermodulation distortion appear as signals that are separated from the original signals by the frequency difference of the original signals. The level of this intermodulation distortion depends on the levels and frequencies of the input signals. When two signals are input, the distortion is observed as 3rd order distortion, and when the input signal level is decreased by 10 dB, the distortion decreases by 30 dB. Figure 41 shows this relationship and the point (where the input signal meets the distortion component) is called the intercept point.

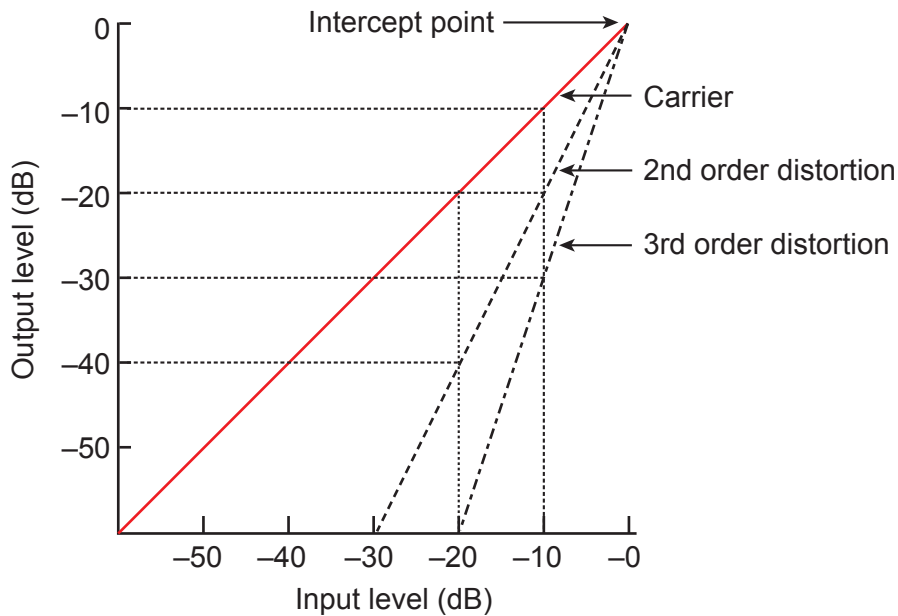

Figure 42

Intermodulation distortion is even generated in the spectrum analyzer itself and this distortion component is determined by the mixer input level. Consequently, when measuring intermodulation distortion using a spectrum analyzer, it is necessary to take care about the mixer input level. It is possible to determine whether or not the DUT or the spectrum analyzer is generating the distortion by observing whether or not the distortion component changes when the spectrum analyzer input attenuation value is varied.

When the spectrum analyzer is generating the distortion, the distortion component changes by 15 dB when the input attenuation is varied by 5 dB. Consequently, in this case, it is necessary to increase the value of the input attenuator to the point where the distortion does not change. In addition, when two signals are input to the DUT, the two signal sources cause mutual interference and hence intermodulation distortion occurs. To distinguish this, confirm whether or not the distortion changes by a factor of three relative to the attenuation value when the attenuator in front of the DUT is varied. When the distortion component does not change by a factor of three, insert an isolator between the signal combiner and the signal sources.

C/N measurement

The output signal from equipment such as a signal generator is not a pure sine wave, and as well as harmonic components, it includes noise of amplitude components and frequency components. These are generally called AM noise and FM (phase) noise. Generally, the AM noise is lesser in magnitude in comparison to the FM noise so measurement of FM noise is explained here.

The FM noise exists just above and below the carrier wave as shown in Figure 42 and is expressed as the ratio of the single sideband phase noise power to the carrier wave power within a 1 Hz bandwidth for a specified frequency offset from the carrier. When a spectrum analyzer is used, the carrier wave power and the sideband noise can be viewed directly on screen. However, the following points must be noted when using a spectrum analyzer.

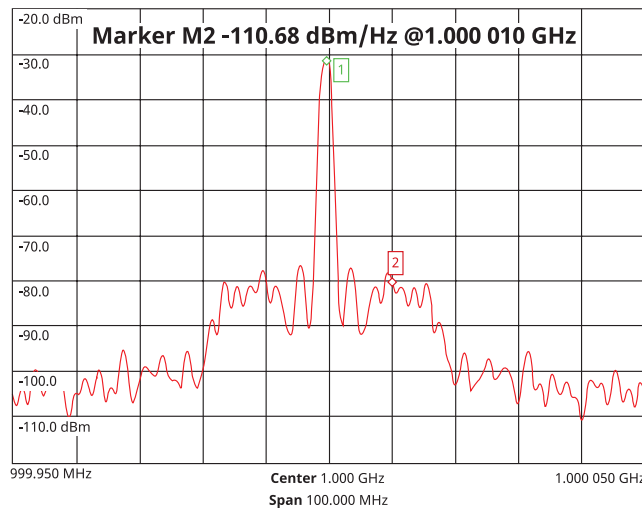

Figure 43

1) Averaging Noise Power

Since a spectrum analyzer has a peak hold circuit in front of the A/D converter, when noise is measured, the maximum power of the noise over the sampling period is displayed. Generally, noise is evaluated as the average value of the power against time. Consequently, it is necessary to use a sampling detector and to narrow the video bandwidth in order to average the noise power.

2) Conversion for Noise Bandwidth

Since the value of the measured noise power depends on the noise bandwidth used, correction for a 1 Hz noise bandwidth is required.

3) Correction of Average Noise Value

With a spectrum analyzer, since the signal is logarithmically converted and envelope detected, the average value of the noise appears to be lower than the actual RMS noise value, so this value must also be corrected.

Occupied Frequency Bandwidth

A common measurement carried out on radio transmitters is that of occupied frequency bandwidth (OBW). This measurement calculates the bandwidth containing the specified amount of the total integrated power of the displayed spectrum. However there are two different methods of calculation depending on the technique used to modulate the carrier.

a) XdB Down method

The occupied frequency bandwidth is defined as the bandwidth between the upper and lower frequency points at which the signal level is XdB below the peak carrier value (Figure 43).

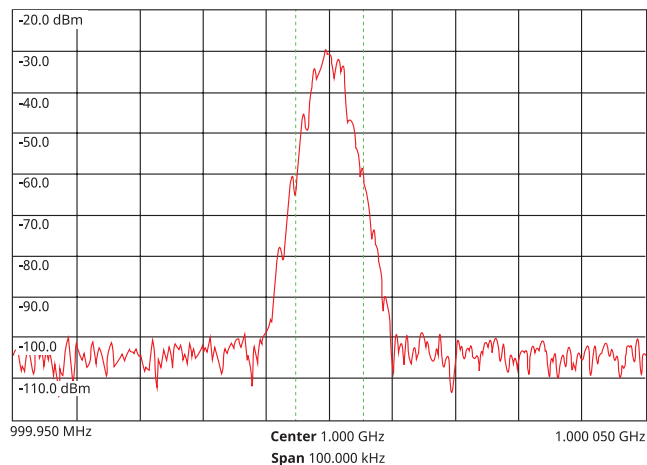

Figure 44

b) N% method

The occupied frequency bandwidth is calculated as the bandwidth containing N% of the power transmitted where N can be between 1% and 99%. A typical example is shown in Figure 44.

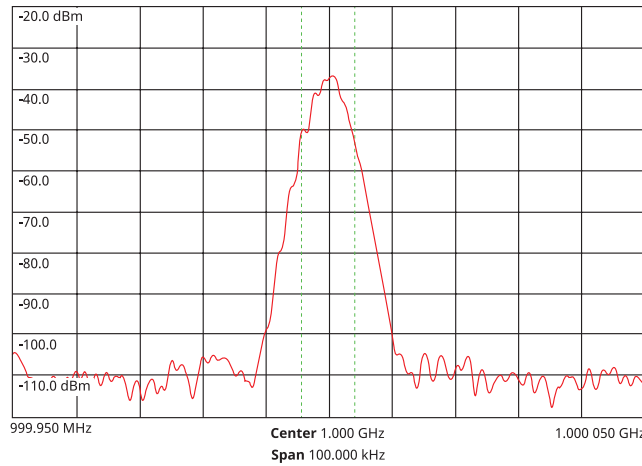

Figure 45

Adjacent Channel Leakage Power

Another common transmitter measurement is that of adjacent channel leakage power. This is defined as the ratio of the amount of leakage power in an adjacent channel to the total transmitted power. In order to calculate the upper and lower adjacent channel values, the spectrum analyzer needs three parameters to be specified:

- The channel separation
- The measurement channel bandwidth
- The adjacent channel bandwidth (if different from measurement channel bandwidth) and
- The center frequency of the reference channel

The measurement is applicable to both modulated and unmodulated signals and provides a means of assessing the transmitters selectivity (Figure 45).

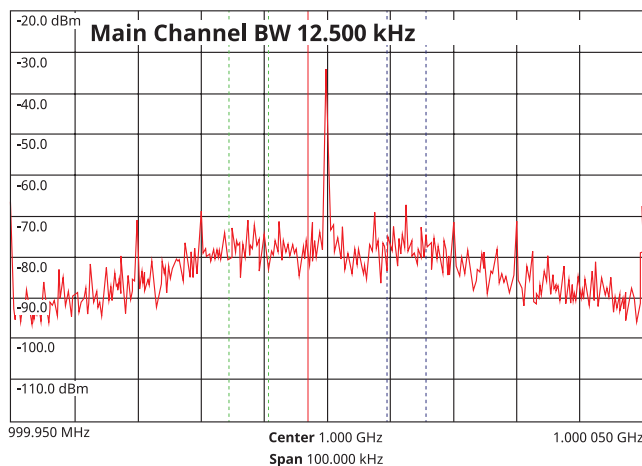

Figure 46

Burst Average Power

Time domain spectrum analysis is a vital tool for analyzing pulsed or burst signals. One important measurement is burst average power which computes the average power within the burst "on" time (Figure 46). Using the same measurement function, the average power within bursts can also be measured.



Figure 47

Error Vector Magnitude

As indicated earlier, signal analyzers are used to measure digital modulation. Vector and constellation diagrams are used to display the results.

Error Vector Magnitude (EVM) is a measure used to quantify the quality or performance of a modulated signal from a transmitter or receiver. In simple terms, if we consider a constellation diagram the EVM is the magnitude of the difference between the measured vector and the ideal (reference) vector. See Figures 47 and 48.

EVM is influenced by a number of IQ-parameters; Phase Error, Frequency Error, Magnitude Error, and Phase Noise.

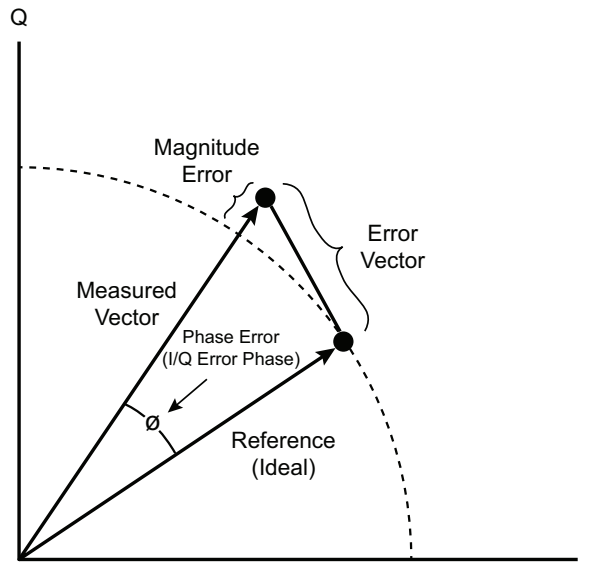

Figure 48

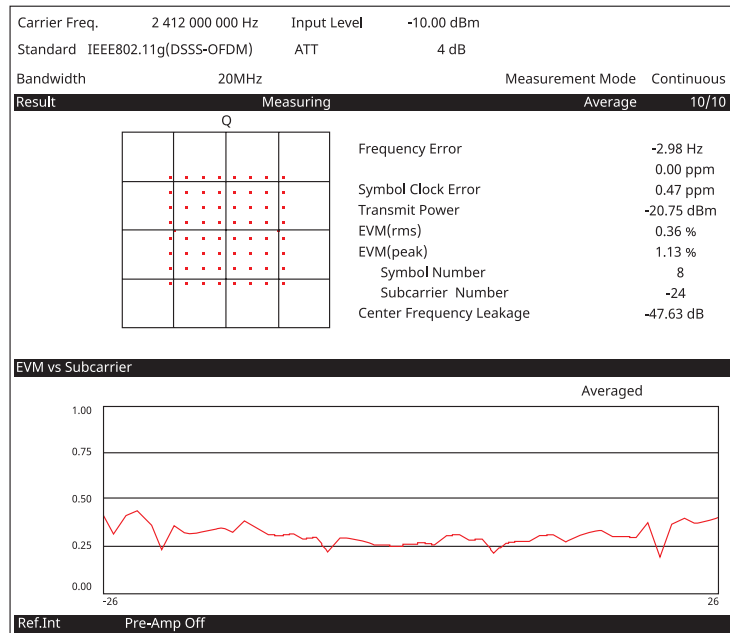

Figure 49

APPENDIX A

Spectrum Analyzer Conversion Factors

50 Ω Input Impedance				
To → From ↓	dBm	dBV	dBmV	dB μ V
dBm	0	-13	+47	+107
dBV	+13	0	+60	+120
dBmV	-47	-60	0	+60
dB μ V	-107	-120	-60	0

70 Ω Input Impedance				
To → From ↓	dBm	dBV	dBmV	dB μ V
dBm	0	-11.25	+48.7	+108.7
dBV	+11.25	0	+60	+120
dBmV	-48.75	-60	0	+60
dB μ V	-108.75	-120	-60	0

SWR – Reflection Coefficient – Return Loss

SWR	Reflection Coefficient	Return Loss (dB)	SWR	Reflection Coefficient	Return Loss (dB)
17.391	0.8913	1	1.0580	0.0282	31
8.7242	0.7943	2	1.0515	0.0251	32
5.8480	0.7079	3	1.0485	0.0224	33
4.4194	0.6310	4	1.0407	0.0200	34
3.5698	0.5623	5	1.0362	0.0178	35
3.0095	0.5012	6	1.0322	0.0158	36
2.6146	0.4467	7	1.0287	0.0141	37
2.3229	0.3981	8	1.0255	0.0126	38
2.0999	0.3548	9	1.0227	0.0112	39
1.9250	0.3162	10	1.0202	0.0100	40
1.7849	0.2818	11	1.0180	0.0089	41
1.6709	0.2512	12	1.0160	0.0079	42
1.5769	0.2239	13	1.0143	0.0071	43
1.4985	0.1995	14	1.0127	0.0063	44
1.4326	0.1778	15	1.0113	0.0056	45
1.3767	0.1585	16	1.0101	0.0050	46
1.3290	0.1413	17	1.0090	0.0045	47
1.2880	0.1259	18	1.0080	0.0040	48
1.2528	0.1122	19	1.0071	0.0030	49
1.2222	0.1000	20	1.0063	0.0032	50
1.1957	0.0891	21	1.0057	0.0028	51
1.1726	0.0794	22	1.0050	0.0025	52
1.1524	0.0708	23	1.0045	0.0022	53
1.1347	0.0631	24	1.0040	0.0020	54
1.1192	0.0562	25	1.0036	0.0018	55
1.1055	0.0501	26	1.0032	0.0016	56
1.0935	0.0447	27	1.0028	0.0014	57
1.0829	0.0398	28	1.0025	0.0013	58
1.0736	0.0355	29	1.0022	0.0011	59
1.0653	0.0316	30	1.0020	0.0010	60

Power Measurement

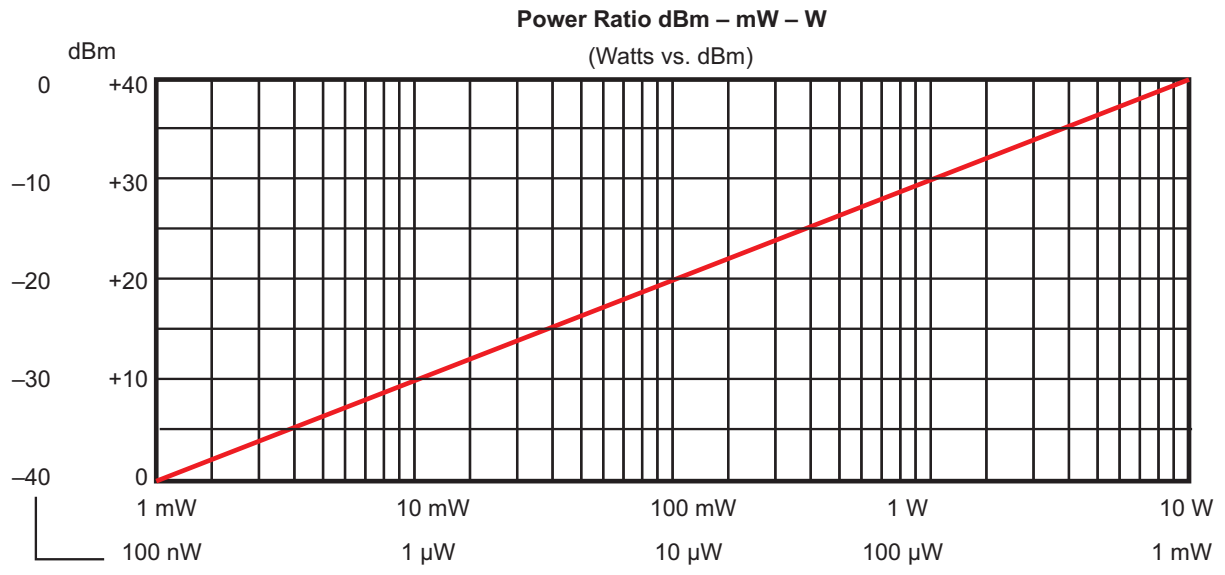

APPENDIX B

Amplitude Modulation

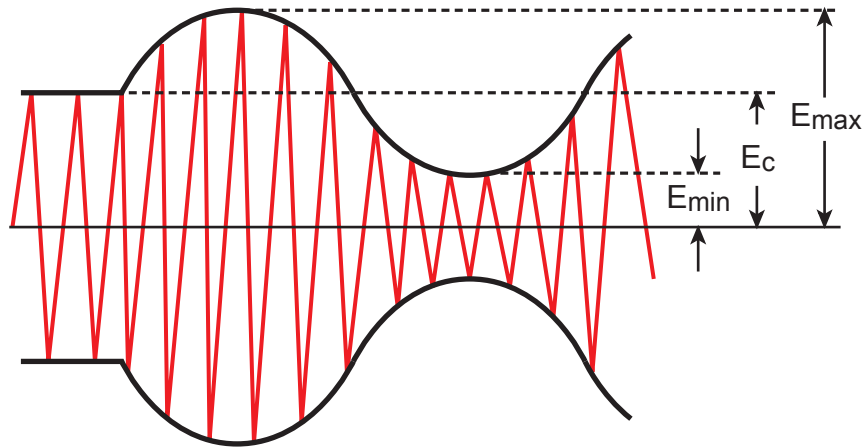

$$\%M = \frac{(E_{\max} - E_{\min})}{(E_{\max} + E_{\min})} \times 100$$

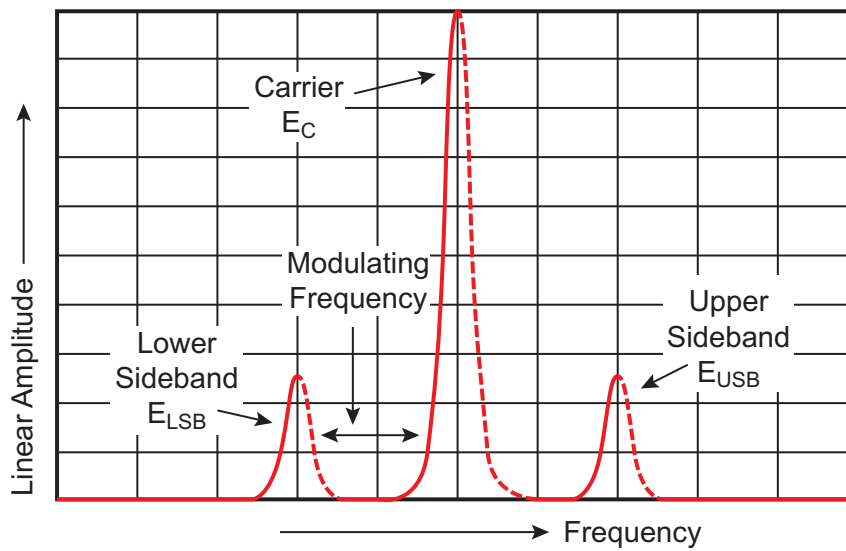

$$\%M = \frac{2E_{LSB}}{E_c} \times 100$$

Ec	
% Modulation	Side Level Below Carrier (dB)
1	46
2	40
19	26
20	20
30	16.5
40	14
50	12
60	10.4
70	9.1
80	7.9
90	6.9
100	6.0
Sideband Level Below Carrier (dB)	% Modulation
10	63
20	20
30	6.3
40	2.0
50	0.63
60	0.2
70	0.063
80	0.02

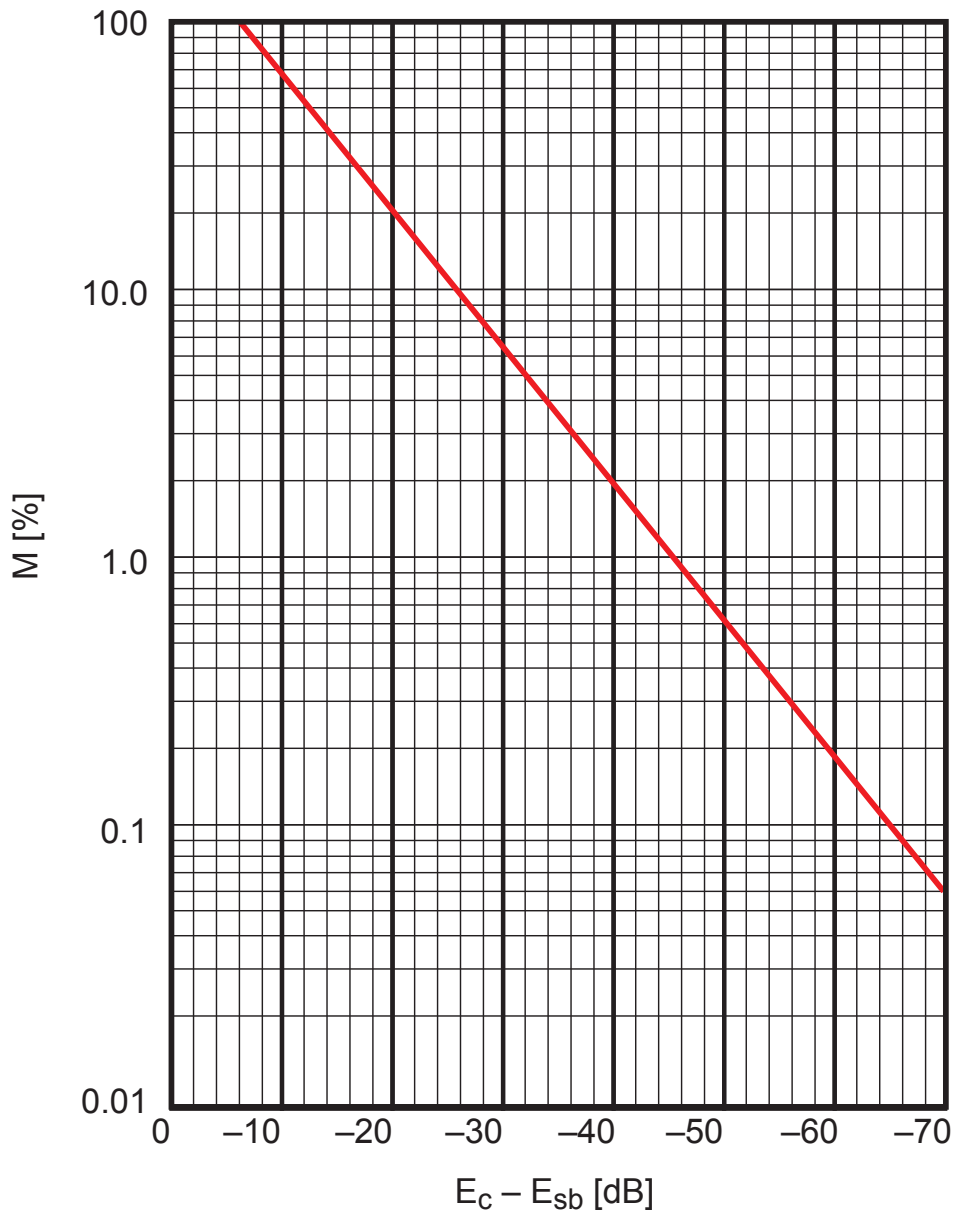

APPENDIX C

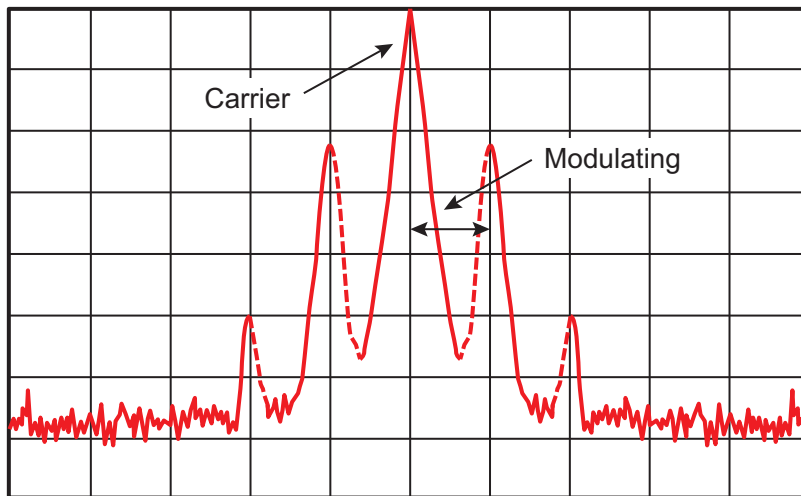
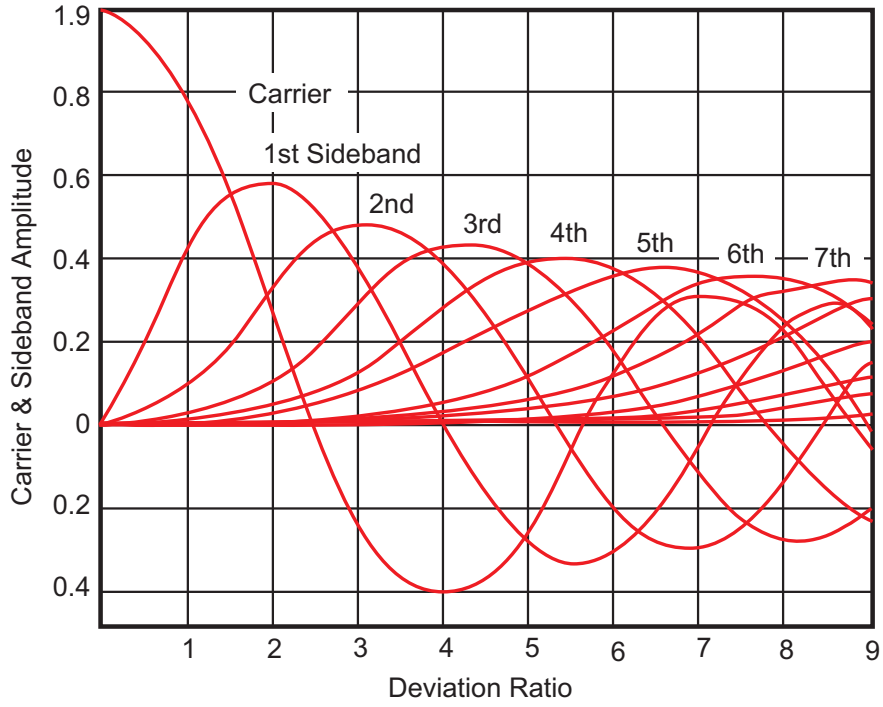

Bessel Functions

Carrier Bessel NULL Number	$M = \Delta F / f$
1st	2.4048
2nd	5.5201
3rd	8.6531
4th	11.7915
5th	14.9309
6th	18.0711
7th	21.2116
8th	24.3525
9th	27.4935
10th	30.6346

Where M = modulation index
 ΔF = deviation
 f = modulating frequency

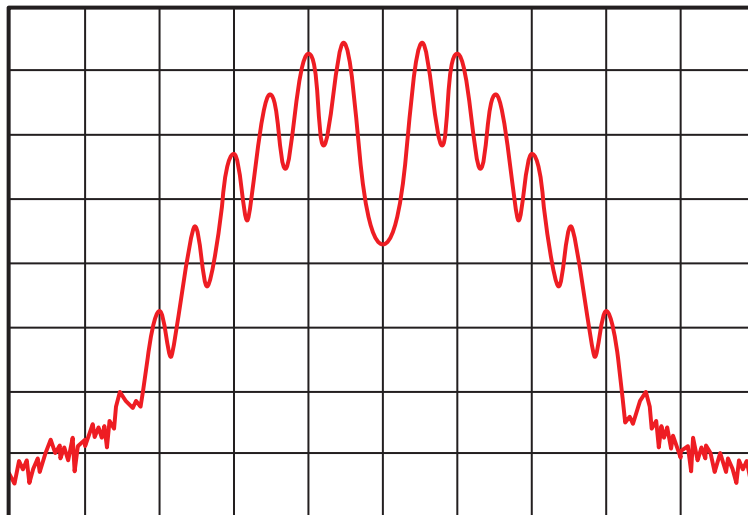

1st Sideband Bessel NULL Number	$M = \Delta F/f$
1st	3.83
2nd	7.02
3rd	10.17
4th	13.32
5th	16.47
6th	19.62
7th	22.76
8th	25.90
9th	29.05

Where M = modulation index
 ΔF = deviation
 f = modulating frequency

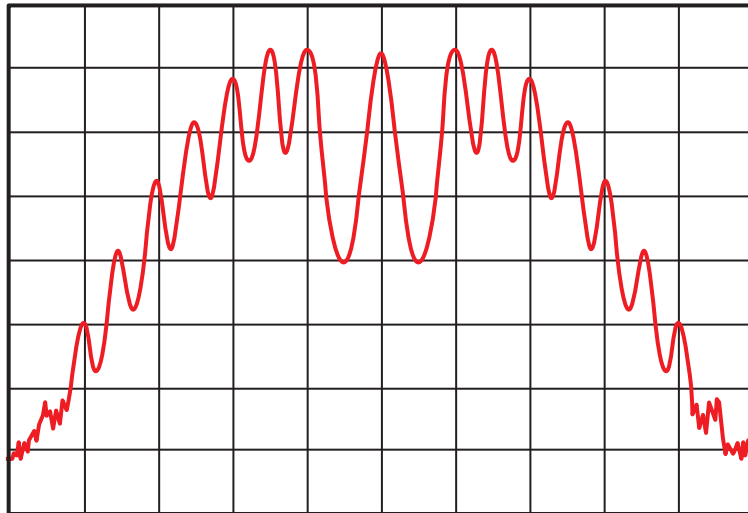

APPENDIX D

Pulse Modulation

$$f_{rep} = \frac{1}{t_{rep}}$$

$$t_{rep} = \frac{\text{Sweep time/Div}}{\text{No. of Peaks/Div}}$$

$$t_{pw} = \frac{1}{\text{Sidelobe Width}}$$

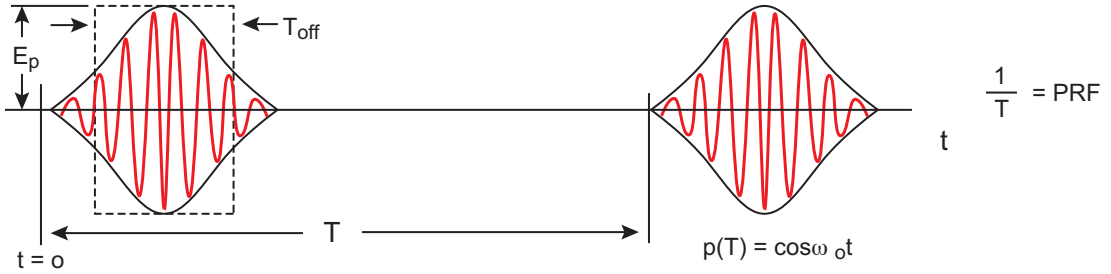

T_{eff} = Width of Rectangular Pulse of same height and area as pulse applied to analyzer = $\int_0^T \frac{p(t) dt}{E_p}$

Optimum RBW as a Function of Pulse Width

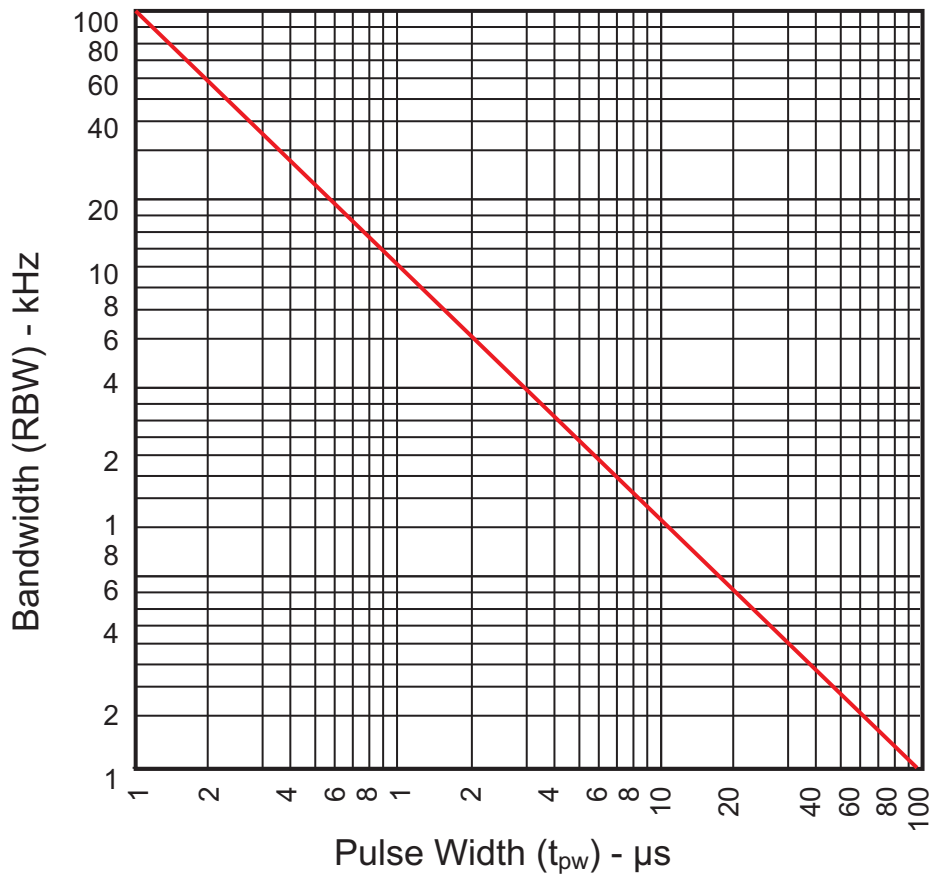

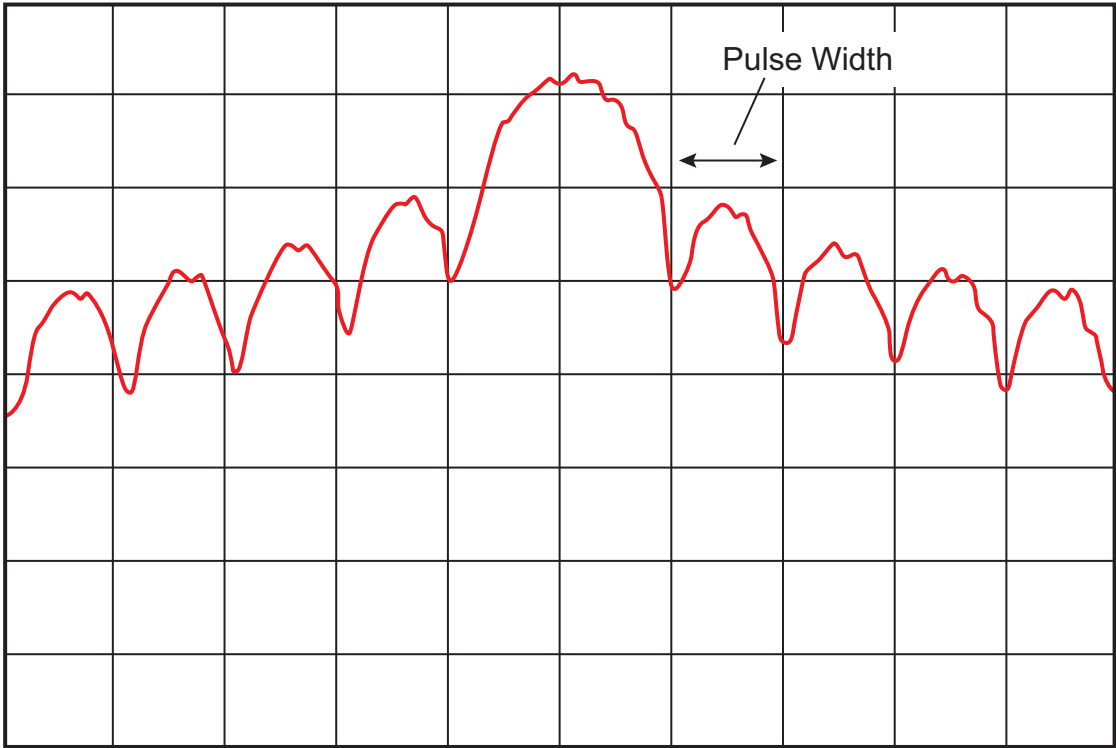

APPENDIX E

Intermodulation Distortion / Intercept Points

Calculating Intercept Points requires knowledge of:

- 1) The order (normally 2nd or 3rd) of the distortion product
- 2) Input drive level in dBm (example: -30 dBm)
- 3) The desired or specified suppression of intermodulation products below the drive level, expressed in dB

The equation for calculating the intercept point is:

$$I = \frac{\Delta}{(N-1)} + S$$

where: I = intercept point level in dBm for any intermodulation product order

Δ = suppression of intermodulation products below drive level in dB

N = order of the intermodulation product

S = drive level of the input tones (signals) in dBm

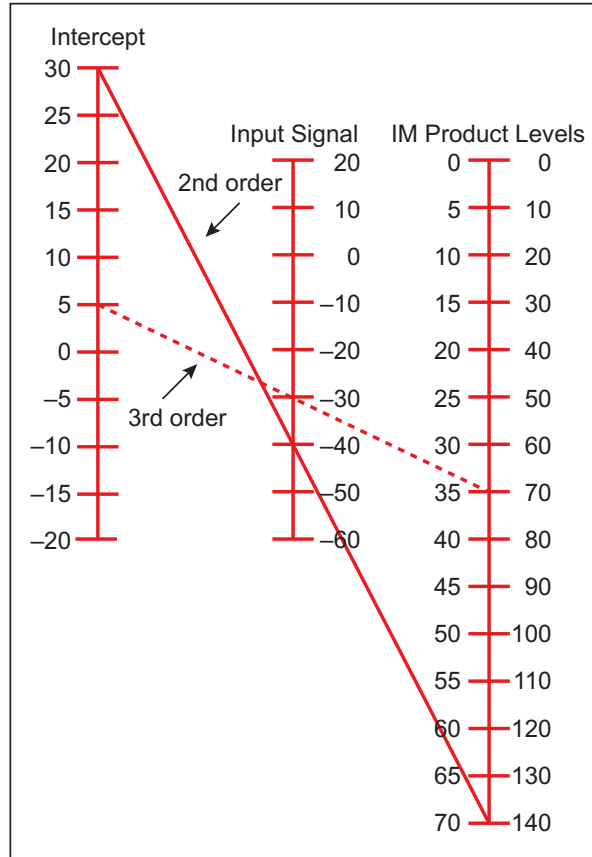

• United States

Anritsu Americas Sales Company

450 Century Parkway, Suite 190, Allen, TX 75013 U.S.A.
Phone: +1-800-Anritsu (1-800-267-4878)

• Canada

Anritsu Electronics Ltd.

Americas Sales and Support

450 Century Parkway, Suite 190, Allen, TX 75013 U.S.A.
Phone: +1-800-Anritsu (1-800-267-4878)

• Brazil

Anritsu Eletronica Ltda.

Praça Amadeu Amaral, 27 - 1 Andar
01327-010 - Bela Vista - Sao Paulo - SP, Brazil
Phone: +55-11-3283-2511
Fax: +55-11-3288-6940

• Mexico

Anritsu Company, S.A. de C.V.

Blvd Miguel de Cervantes Saavedra #169 Piso 1, Col. Granada
Mexico, Ciudad de Mexico, 11520, MEXICO
Phone: +52-55-4169-7104

• United Kingdom

Anritsu EMEA Ltd.

200 Capability Green, Luton, Bedfordshire, LU1 3LU, U.K.
Phone: +44-1582-433200
Fax: +44-1582-731303

• France

Anritsu S.A.

12 avenue du Québec, Immeuble Goyave,
91140 VILLEBON SUR YVETTE, France
Phone: +33-1-60-92-15-50

• Germany

Anritsu GmbH

Nemetschek Haus, Konrad-Zuse-Platz 1,
81829 München, Germany
Phone: +49-89-442308-0
Fax: +49-89-442308-55

• Italy

Anritsu S.r.l.

Spaces Eur Arte, Viale dell'Arte 25, 00144 Roma, Italy
Phone: +39-6-509-9711

• Sweden

Anritsu AB

Kistagången 20 B, 2 tr, 164 40 Kista, Sweden
Phone: +46-8-534-707-00

• Finland

Anritsu A/S

Technopolis Aviapolis, Teknobulevardi 3-5 (D208.5.),
FI-01530 Vantaa, Finland
Phone: +358-20-741-8100

• Denmark

Anritsu A/S

c/o Regus Winghouse, Ørestads Boulevard 73, 4th floor,
2300 Copenhagen S, Denmark
Phone: +45-7211-2200

• Spain

Anritsu EMEA Ltd.

Representation Office in Spain

Paseo de la Castellana, 141. Planta 5, Edificio Cuzco IV
28046, Madrid, Spain
Phone: +34-91-572-6761

• Austria

Anritsu EMEA GmbH

Am Belvedere 10, A-1100 Vienna, Austria
Phone: +43-(0)1-717-28-710

• United Arab Emirates

Anritsu EMEA Ltd.

Anritsu A/S

Office No. 164, Building 17, Dubai Internet City
P. O. Box - 501901, Dubai, United Arab Emirates
Phone: +971-4-3758479

• India

Anritsu India Private Limited

6th Floor, Indiqueb ETA, No.38/4, Adjacent to EMC2,
Doddanekundi, Outer Ring Road, Bengaluru - 560048, India
Phone: +91-80-6728-1300
Fax: +91-80-6728-1301

• Singapore

Anritsu Pte. Ltd.

1 Jalan Kilang Timor, #07-04/06 Pacific Tech Centre
Singapore 159303
Phone: +65-6282-2400
Fax: +65-6282-2533

• Vietnam

Anritsu Company Limited

16th Floor, Peakview Tower, 36 Hoang Cau Street, O Cho Dua Ward,
Dong Da District, Hanoi, Vietnam
Phone: +84-24-3201-2730

• P.R. China (Shanghai)

Anritsu (China) Co., Ltd.

Room 2701-2705, Tower A, New Caohejing International
Business Center No. 391 Gui Ping Road Shanghai, 200233, P.R. China
Phone: +86-21-6237-0898
Fax: +86-21-6237-0899

• P.R. China (Hong Kong)

Anritsu Company Ltd.

Unit 1006-7, 10/F., Greenfield Tower, Concordia Plaza,
No. 1 Science Museum Road, Tsim Sha Tsui East,
Kowloon, Hong Kong, P.R. China
Phone: +852-2301-4980
Fax: +852-2301-3545

• Japan

Anritsu Corporation

8-5, Tamura-cho, Atsugi-shi, Kanagawa, 243-0016 Japan
Phone: +81-46-296-6509
Fax: +81-46-225-8352

• Korea

Anritsu Corporation, Ltd.

8F, A TOWER, 20, Gwacheondaero 7-gil, Gwacheon-si,
Gyeonggi-do, 13840, Republic of Korea
Phone: +82-2-6259-7300
Fax: +82-2-6259-7301

• Australia

Anritsu Pty. Ltd.

Unit 20, 21-35 Ricketts Road, Mount Waverley, Victoria 3149, Australia
Phone: +61-3-9558-8177
Fax: +61-3-9558-8255

• Taiwan

Anritsu Company Inc.

7F, No. 316, Sec. 1, NeiHu Rd., Taipei 114, Taiwan
Phone: +886-2-8751-1816
Fax: +886-2-8751-1817

List Revision Date: 20230901



Anritsu utilizes recycled paper and environmentally conscious inks and toner.



© Anritsu All trademarks are registered trademarks of their respective owners. Data subject to change without notice. For the most recent specifications visit: www.anritsu.com

11410-00796, Rev. B Printed in United States 2023-09
©2023 Anritsu Company. All Rights Reserved.