

# Understanding **IBW**

In-Building Wireless:  
**DAS to Small Cells**



## Understanding IBW Solutions

---

Introduction.....	4
IBW market overview .....	5
IBW funding/ownership.....	8
IBW system architectures .....	9
Distributed Antenna Systems (DAS).....	10
Passive DAS.....	11
Signal sources .....	12
RF combining.....	12
Signal distribution.....	13
Antennas.....	13
MIMO Passive DAS.....	15
Passive DAS pros and cons.....	16
Active DAS.....	17
Signal Sources .....	18
Point-of-Interface (POI) tray.....	18
Head-end unit .....	19
Signal distribution.....	20
Radio units.....	20
Antennas.....	21
MIMO Active DAS.....	21
Active DAS pros and cons .....	22
Hybrid DAS.....	23
Hybrid DAS pros and cons .....	23
Digital DAS.....	25
Signal Sources .....	26
Head-end unit .....	26
Signal distribution.....	27
Radio unit/antenna.....	27
Digital DAS pros and cons.....	28
Distributed Radio Systems (DRS).....	29
DRS pros and cons.....	30
Distributed Small Cells (DSC) .....	31
DSC pros and cons.....	32
Summary .....	33
Anritsu test solutions for optimum in-building wireless performance.....	33
Cable and Antenna Analyzers.....	33
Passive Intermodulation (PIM) Analyzers .....	33
Spectrum Analyzers .....	34
Base Station Analyzers .....	34
Land Mobile Radio (LMR) Analyzers.....	34
Visual Inspection Microscopes.....	34
Optical light source/optical power meter .....	34
Multi-function optical time domain reflectometers (OTDR).....	34
Optical transport analyzers .....	35
Anritsu 's Training Services.....	35

## Understanding IBW Solutions

---

### Introduction

In the early 1980's when cellular communications was first introduced, in-building wireless (IBW) coverage was not a concern. After all, "car phones" were devices permanently installed in cars allowing the "privileged few" to place and receive voice calls while on the go. It wouldn't even occur to you to try to use your "bag phone" inside a building. That's what land lines were for.

Fast forward 10 years to the mid 1990's and things began to change. The phones were becoming small enough to carry with you and it became noticeable that the new 2G services being deployed at 1800 MHz and 1900 MHz sometimes didn't work indoors. Thank goodness your one-way, 900 MHz pager still worked inside most buildings! As more and more business travelers adopted the mobile phone, the need for wireless coverage inside metro systems and airports starting becoming a priority for many mobile operators.

Fast forward another 10 years to the mid 2000's and the wireless landscape had changed dramatically. Mobile phones were now small enough to fit in your pocket and were routinely being used to send and receive text messages (killing the pager market). The really techno savvy business travelers were even using their phones to send and receive emails! New 3G systems were starting to gain traction with speeds fast enough to view web pages on your phone without having to wait a lifetime. Since these 3G systems were often deployed using even higher frequencies (2100 MHz) the lack of 3G coverage inside buildings became even more noticeable.

Then it happened! Apple™ introduced the iPhone in 2007, forever changing our expectation for mobile devices. The large touch screen interface combined with "high speed" 3G wireless data connectivity finally made the mobile internet something useable by the masses. Wondering "what's the killer app that will justify the cost of 3G networks" was no longer a question for mobile operators. Instead, the question became "what can we do to keep up with the growing demand for wireless data?"

Fast forward to today and we find our mobile phones as devices we simply cannot live without. They are our camera, video recorder, email device, social media access device, text messaging device, book, newspaper, gaming device, and oh yeah...our mobile telephone. We expect these devices to work well everywhere we go, particularly inside buildings where according to various reports, >80% of mobile data traffic is generated. Answering this demand is a technical as well as economic challenge for mobile operators worldwide. This paper provides an overview of the in-building wireless (IBW) ecosystem with particular focus on the architectures currently deployed to supply in-building coverage and capacity using licensed spectrum.



## Understanding IBW Solutions

### IBW Market Overview

The purpose of an in-building wireless (IBW) system is to provide enhanced network coverage and/or capacity when the existing macro network is not able to adequately service the demand. Coverage may be poor due to high penetration losses caused by the building structure or due to low emissivity glass installed to improve the thermal performance of the building. In dense urban environments, adjacent buildings may create an RF barrier that blocks coverage from nearby macro sites. Tall buildings typically have poor coverage on upper floors since macro site antennas, many floors below, are specifically designed to suppress energy radiating above the horizon. Capacity may be an issue in venues such as stadiums, coliseums and convention centers where many thousands of users may be trying to simultaneously access the network.

Since IBW systems are not free, there must be a compelling business reason for an operator to incur the CAPEX and ongoing OPEX costs associated with deploying these enhanced services. In high visibility cases, such as airports, stadiums and convention centers, the justification may be obvious. In other locations such as shopping centers or office buildings, the business case may be less compelling.

What constitutes “adequate coverage” and a “compelling business reason” varies from operator to operator as well as from region to region. Historically, the majority of Distributed Antenna Systems (DAS) have been deployed in the North America and Asia Pacific regions, as shown in Figure 1.

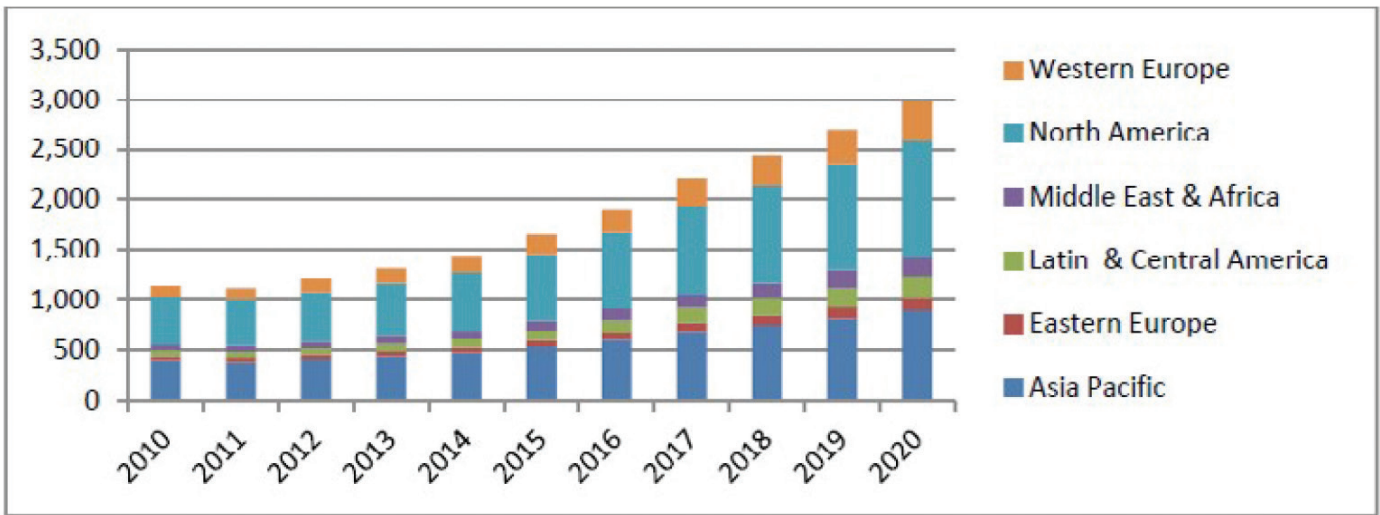

Figure 1. DAS Node Unit Shipments by Region 2010 – 2020 (thousands of units) Source: SNS Research

## Understanding IBW Solutions

The regional distribution of DAS nodes surprises many since there is not a one-to-one correlation between the number of installed systems and the number of mobile subscribers per region. In an attempt to better understand this distribution, an assumption was made that the number of DAS nodes required could be correlated to the number of tall buildings and the number of large sporting venues in each region. Data from the Emporis “skyline ranking” website was used to evaluate the number of tall buildings (those >20 floors tall) and data from Wikipedia was used to evaluate the number of large stadiums (those seating >40,000 people) in each region. The tall building data from Emporis contained a weighting factor based on the number of floors, which seemed to be relevant to this analysis. On average, it appeared that one tall building point represented approximately 50 people, assuming an average of 100 people per floor in a typical building. This point system was applied to the seating capacity of stadiums, resulting in the values per region shown in Figure 2. The third column in the data shows the sum of the tall building points and large stadium points for each region.

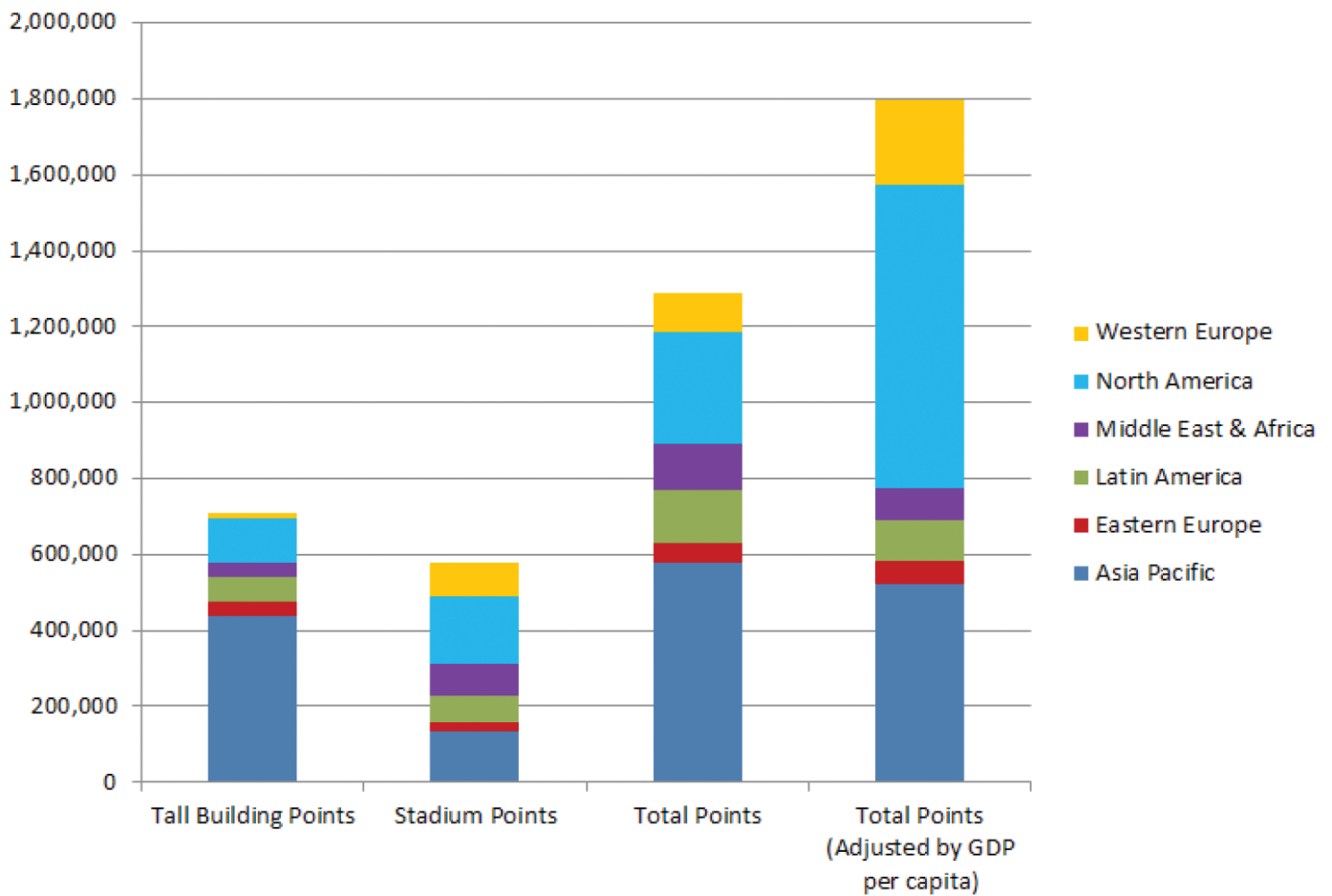

Figure 2. Relative In-Building Wireless Deployments by Region

## Understanding IBW Solutions

---

It is not surprising that the Asia Pacific region contains the largest number of tall buildings, with cities such as Hong Kong, Singapore, Seoul, Shanghai and Bangkok occupying five of the top 10 positions in the global skyline ranking. On the large stadium side, nine of the world's 11 stadiums seating >100,000 people are in North America, with eight of those nine being college football stadiums in the USA. The combined results have somewhat similar weighting to the historical DAS deployment data, with an exception that the Asia Pacific and North America weightings are reversed. Multiplying the point totals by relative Gross Domestic Product (GDP) per capita for each region creates a distribution remarkably similar to the historical DAS deployment distribution. The exact mechanism of the GDP per capita correlation is not clear. It could mean that operators in wealthier regions have larger capital budgets for investing in IBW systems. Or, since higher GDP per capita regions typically have a higher percentage of post-paid (vs. pre-paid) subscribers, operators in those regions may feel more compelled to improve IBW coverage to retain (or attract) post-paid customers.



## IBW Funding/Ownership

---

A variety of funding/ownership models are available for IBW systems depending largely on who stands to benefit the most from the enhanced wireless services. For enterprise customer campuses and other venues where an operator wants to differentiate their level of service relative to competitors, the operator may negotiate a lease directly with the building owner and bear the full cost of designing, permitting, installing and maintaining the IBW system in exchange for exclusive coverage rights. The opposite case also occurs where a building owner is required by local regulations to provide public safety coverage at critical areas within the building. In this case, the IBW system is just another building code requirement, like the sprinkler system, that is necessary to obtain an occupancy permit. For public safety coverage, the building owner bears 100% of the cost of the IBW system, often paying a specialized 3rd party contractor to design and install the system.

In other cases, such as large shopping centers and stadiums, the benefit of enhanced coverage and capacity may be mutual. Strong coverage from as many operators as possible benefits the building owner since the largest cross section of potential customers will be satisfied. The ability to efficiently serve a large number of customers accessing social media while shopping or enjoying the “big event” is a win for the mobile operator. Since both the building owner and the mobile operators stand to benefit, a negotiation is required to determine how to equitably share the cost of the IBW system. An added complication in these systems is that the building owner is likely to insist that all operators share the same IBW infrastructure to reduce the physical as well as visual impact on the venue. This offers a financial benefit to each operator but eliminates each operator’s direct control over the performance of the system. In many cases a neutral host is employed to work with all operators during the design phase to understand each operator’s requirements and resolve conflicts. The neutral host may be an IBW integration company, an equipment manufacturer or a 3rd party management company. In some cases the neutral host pays for and maintains the IBW system as an investment, paying a fee to the building owner and negotiating lease agreements with the individual operators.



## IBW System Architectures

In general, IBW solutions can be grouped into three different architectures: Distributed Antenna Systems (DAS), Distributed Radio Systems (DRS) and Distributed Small Cells (DSC.) What makes each group distinctive is the physical location of the network equipment manufacturer (NEM) base band processing and radio resources. In a Distributed Antenna System, the NEM base band processing and radio resources are located in a central location. In a Distributed Radio System, the NEM base band processing is located in a central location and the NEM radio resources are distributed. In a Distributed Small Cell (DSC) system, the NEM base band processing and radio resources are distributed by deployment of multiple “small cell” base stations. Systems deploying this architecture typically include centralized hardware to coordinate the multiple small cells to aggregate backhaul and reduce inter-cell interference.

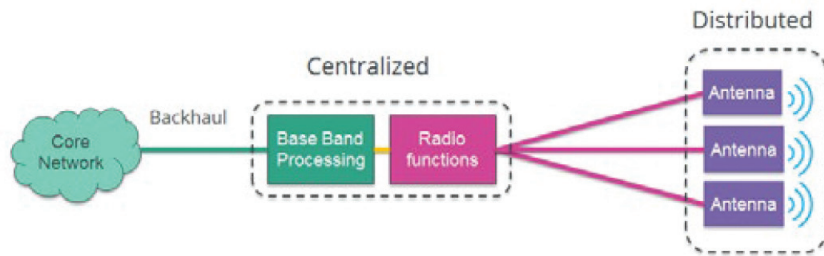

Figure 3. Distributed Antenna System (DAS) Architecture

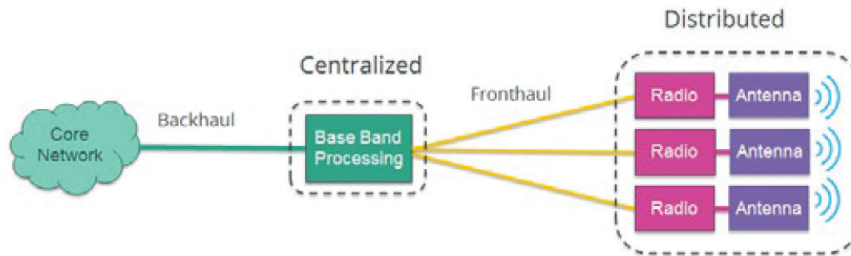

Figure 4. Distributed Radio System (DRS) Architecture

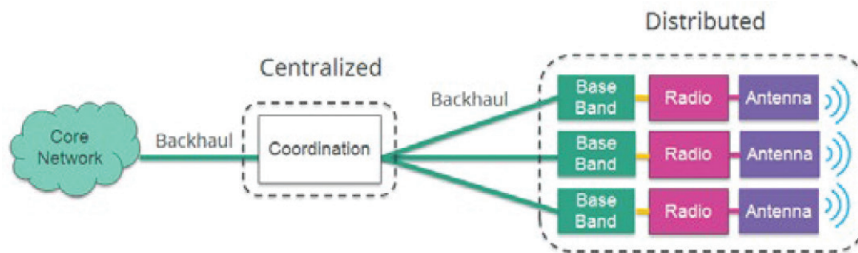

Figure 5. Distributed Small Cell (DSC) Architecture

## IBW System Architectures

---

Deciding which architecture to deploy will vary from application to application and will depend on:

- .... • Objective of the design (coverage, capacity or both)
- .... • Budget
- .... • Venue size/shape/distance between required areas of coverage
- .... • Number of operators sharing the system
- .... • Required technologies: 2G, 3G, 4G
- .... • Long term objectives: (plan for future expansion or not)

Each IBW architecture has its own strengths and weaknesses. As a result, there is no “one size-fits-all” solution that works perfectly for every application. It is expected that the multiple IBW architectures presented in this document will be available for a long time to come, each finding favor in a different segment of the global IBW market.

### **Distributed Antenna Systems (DAS)**

Distributed Antenna Systems (DAS) are the most common method selected by operators to achieve IBW coverage and capacity. Traditionally, the same macro cell base station deployed in the outdoor environment has been deployed indoors to serve as a signal source to feed a network of antennas distributed throughout the venue. Alternatively, a repeater or bi-directional amplifier (BDA) can be deployed as the signal source to amplify downlink signals from a donor site as well as amplify uplink signals from users inside the building. In either case, the network equipment manufacturer’s (NEM) base band processing and radio resources are centrally located, either in a DAS head-end equipment room at the venue or in the shelter of the donor site in the case of a repeater/BDA.

Distributed Antenna Systems (DAS) are able to accept RF inputs from a variety of signal sources, making them network equipment manufacturer, as well as technology (2G, 3G, 4G) neutral. For this reason, a DAS is often the IBW system of choice for multi-operator, multi-NEM, multi-technology applications. Many different types of DAS exist today based on the method used to distribute the NEM’s RF signals to the remote antennas. These include passive DAS, active DAS, hybrid DAS and recently introduced Digital DAS, which will be described in detail in the following sections.

## Passive DAS

In a passive DAS, signals from one or more RF sources are distributed throughout the venue using only passive components (coaxial cable, splitters, directional couplers, etc.). Beyond the signal sources, there are only losses (no gain elements). Sectorization is determined by hard wiring capacity from each signal source to specific zones within the building. Figure 6 is an illustration of a typical passive DAS where one sector of capacity from three different signal sources provides coverage to two floors of a building.

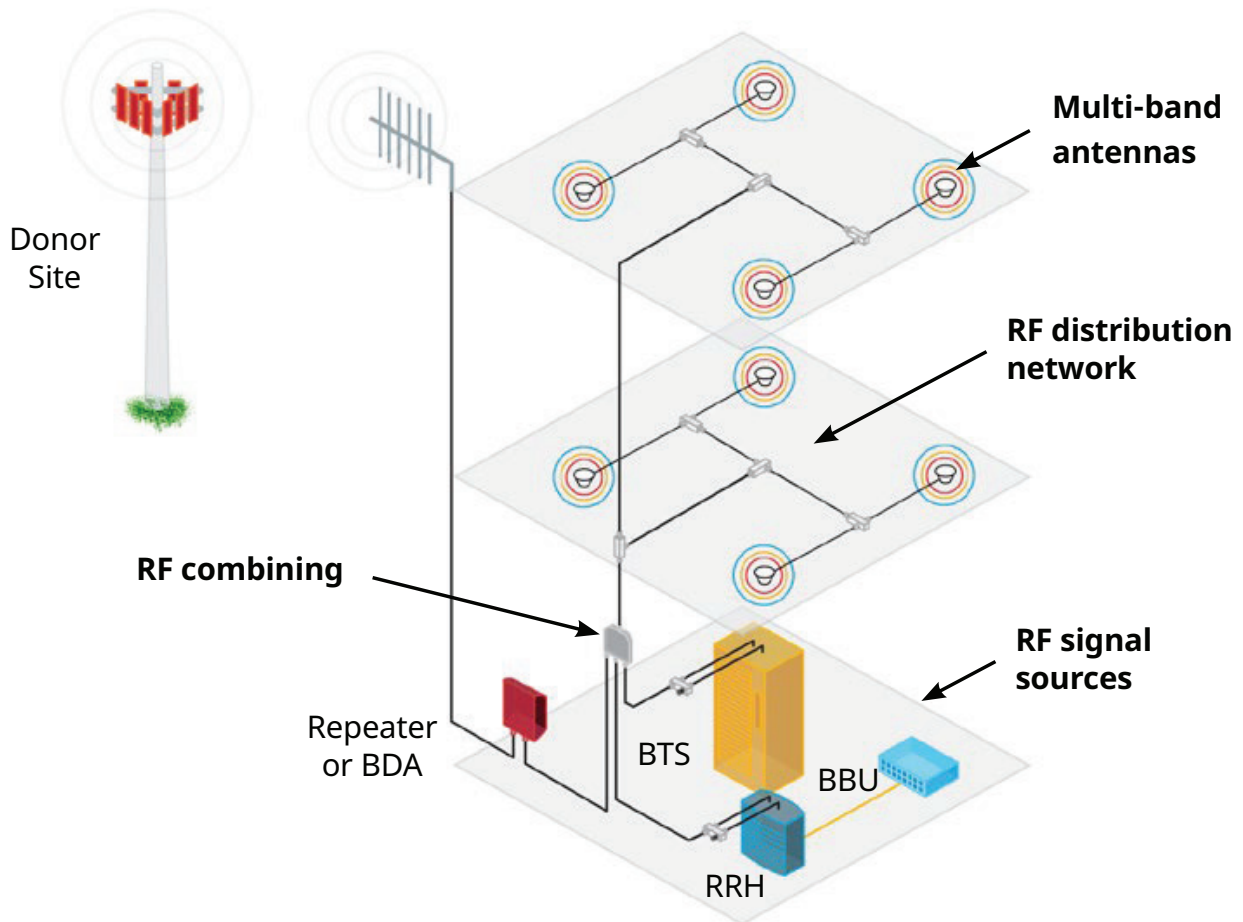

Figure 6. Passive DAS Configuration

## Passive DAS

---

### Signal Sources

Repeaters, BDAs, BTSs, Node-Bs, eNode-Bs and even small cells can be used as signal sources to feed a passive DAS. These signal sources are typically co-located in a restricted access, head-end equipment room somewhere within the venue with access to AC power and telecom services for backhaul to the core networks. The head-end equipment room must have sufficient heating and air conditioning capacity to manage the thermal load of the multiple RF signal sources and supporting electronics. In a large venue, such as a stadium, containing many sectors of capacity from multiple operators, the head-end equipment room can consume significant floor space, requiring careful planning during the DAS design phase.

### RF Combining

Two levels of RF combining are typically found in the head-end equipment room of a passive DAS. The first level is to combine the main and diversity receive paths from each sector. Unlike outdoor sites, which deploy two receive antennas per sector to combat multi-path fading, a DAS uses only one set of antennas per sector (with the exception of MIMO, which will be discussed later.) A wide band, hybrid combiner can be used to feed equal uplink signal levels from the DAS to both the main and diversity receive paths of the base station to prevent diversity imbalance alarms. If the diversity alarm can be disabled via software, the first level of combining is not necessary and the diversity receive branch can be terminated with 50Ω load.



## Passive DAS

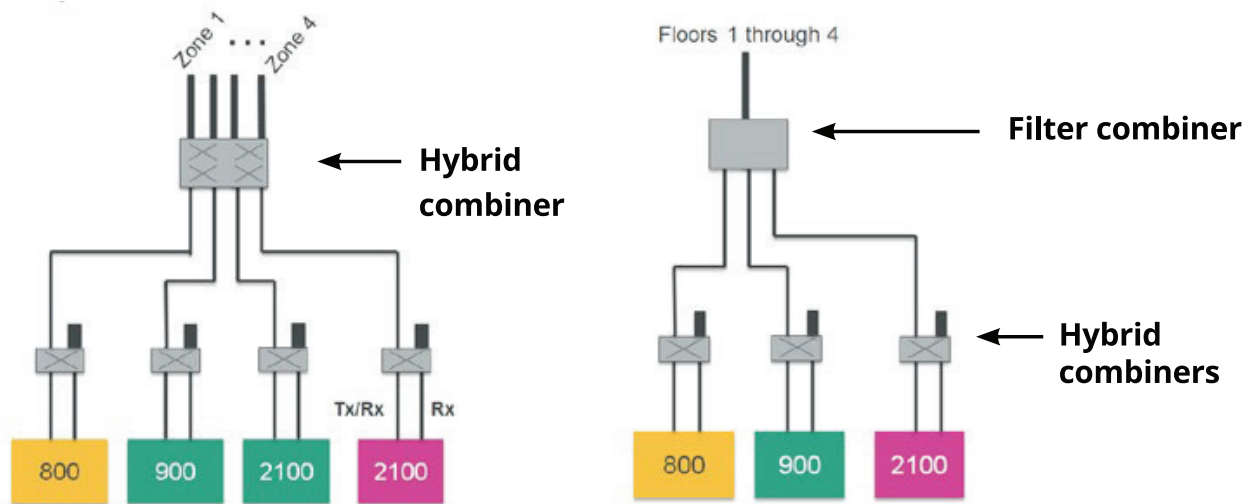

Figure 7. Passive DAS Combining Techniques

A second level of RF combining is required to combine the signal sources serving specific zones within the venue. Low loss, cavity filters can be used for this purpose as well as hybrid combiners. Which type of combiner to use depends on the signal source frequencies, the building configuration, the number of zones supported by each signal source and the required isolation between signal sources.

### Signal Distribution

In a passive DAS, large diameter coaxial cables (7/8" to 1-5/8" diameter) depart the head-end equipment room carrying the RF signals to each zone of coverage. Large diameter cables are required to minimize the signal loss over long distances. These rigid cables can be difficult to pull through the structure, often being routed through designated telecom spaces with multiple bends to avoid structural elements and other building systems. A series of tappers, directional couplers and splitters are used to divide the signal to achieve the desired signal level at each antenna. At the floor level, smaller diameter coaxial cables (1/2" diameter) are typically used to distribute the RF signals. Special plenum rated coaxial cables are typically deployed at the floor level to meet building code requirements. These cables do not contain foam between the center conductor and the outer conductor, requiring an extra degree of skill during installation to properly prepare the cable ends and attach RF connectors. Incorrect assembly techniques can result in high passive intermodulation (PIM) or high reflections, which will degrade the DAS performance.



## Passive DAS

### Antennas

Several different types of antennas are used in passive DAS networks depending on the coverage requirements. Wide band, omni-directional antennas are commonly used in interior spaces with directional panel antennas used near building edges. For optimum performance, the signal level delivered by the IBW system needs to be approximately 10 dB stronger than the signal received from nearby macro sites. This can be a challenge near windows or inside atriums where there may be lower penetration loss from the outside network. Directional antennas placed near the edges pointing inward take advantage of the antenna's directivity, delivering typically 100 times stronger signal on the front side of the antenna compared to the back side of the antenna. This allows the IBW designer to achieve a dominant signal from the IBW system near the building edges without interfering with neighboring macro sites. Directional antennas are also deployed back-to-back for long corridor coverage as well as in stadium applications to cover specific seating areas with narrow antenna beams.

When possible, antennas should be placed in locations with a clear view of the environment they are serving and not placed near metal objects such as light fixtures, ceiling tile frames and metal HVAC ductwork. Placement close to these objects can generate high levels of passive intermodulation, even with transmit power levels as low as 20 dBm (100 mW). Studies conducted by Anritsu indicate that external PIM sources close to IBW antennas are more likely to impact performance at low frequencies (700 MHz, 850 MHz, 900 MHz) than at high frequencies (2100 MHz, 2600 MHz.) Best practice when deploying low frequency band systems is to perform a low power PIM test at each candidate antenna location prior to final installation. Re-locating the antenna as little as 1m from the design location may have little impact on coverage but could have as much as 50 dB impact on the PIM generated by an external source.



## MIMO Passive DAS

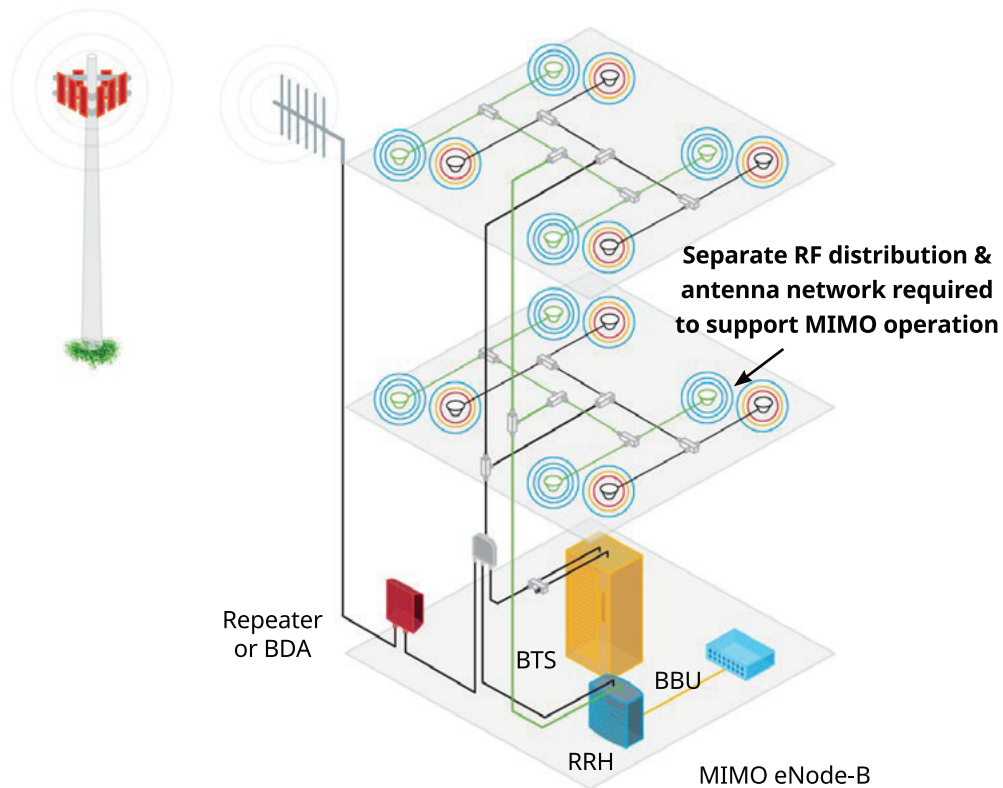

Figure 8. MIMO Passive DAS Configuration

Multiple-Input, Multiple-Output (MIMO) is a technique used in wireless communications to significantly increase channel capacity by exploiting multipath propagation. To achieve the desired capacity gains, multiple independent data streams must be created between the user equipment and the MIMO base station. As shown in Figure 8, this would entail adding a second RF distribution network and a separate set of antennas to enable MIMO operation by the “blue” signal source. If single-polarization antennas are used in a MIMO installation, the antennas must be separated three to seven wavelengths to provide statistically different paths over the air interface. Alternatively, dual-polarized antennas can be installed which contain two orthogonally polarized antenna elements inside a single radome structure. These dual polarized antennas are typically twice the diameter of single-polarization antennas and significantly more expensive due to the design complexity required to achieve good cross-pol discrimination and good pattern shape over a wide operating bandwidth. The benefit, of course, is that only one antenna is visible at each location, which may be important to the building owner.

## MIMO Passive DAS

---

### Passive DAS Pros and Cons

Passive DAS are simple to design and can be deployed with comparatively low material costs. Because there are no active components beyond the NEM equipment, passive DAS offer high reliability with very little ongoing maintenance required. Passive DAS is often the solution of choice for multi-operator systems serving buildings where coverage and capacity requirements are not expected to change significantly over time. In addition, passive DAS are often deployed for public safety applications where an economic yet high reliability solution is needed to enhance coverage within certain areas of a building.

There are some negative attributes of passive DAS that should be taken into account when planning the system. Labor costs can be high due to the challenges associated with routing rigid RF cables over long distances through a building. In addition, the probability of encountering PIM interference is high due to the increased input power required at the signal sources to overcome cable losses and the large number of RF connections distributed throughout the system. Highly skilled installation teams using specialized RF test equipment to verify their work are required to insure proper system performance, which may increase the labor cost of the project.

Passive DAS are also difficult to modify after the installation is completed. Power levels to specific antennas within the DAS are not easy to adjust as a fixed percentage of the input power will arrive at each antenna based on the cable losses and splitting ratio of the installed dividers and couplers. Changing the power arriving at one antenna will impact multiple antennas on the same branch. It is also not easy to change sectorization if capacity needs throughout the venue change over time. Capacity from each signal source is hard wired throughout the facility (like plumbing) and is difficult to re-distribute.

## Active DAS

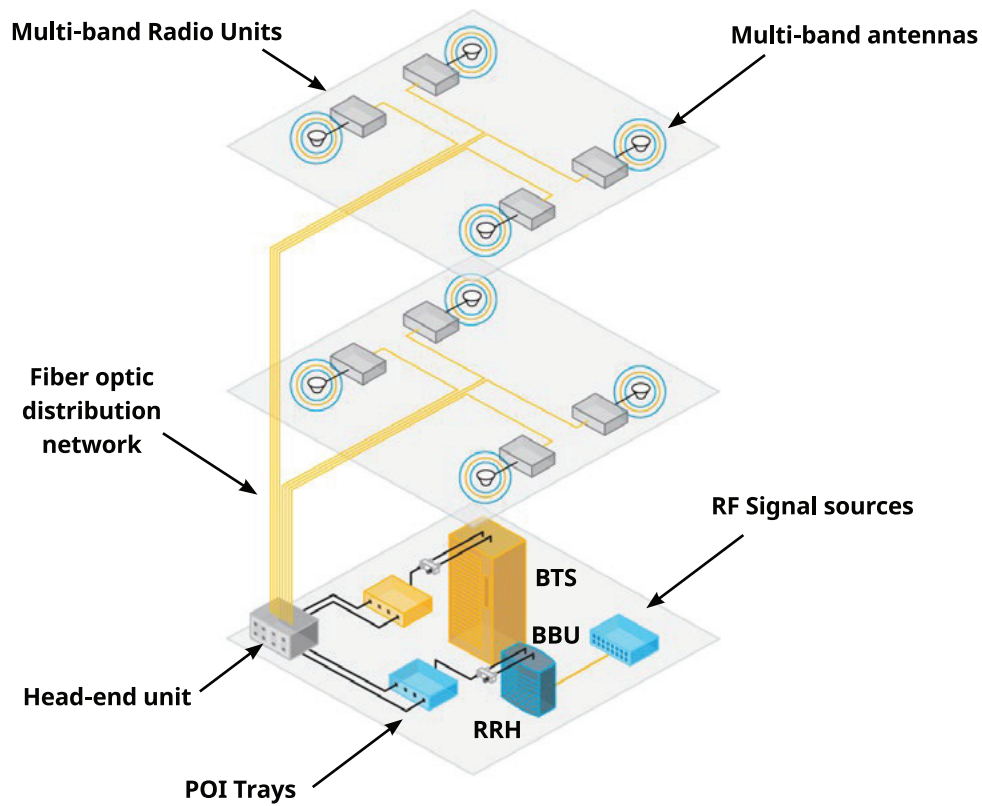

Figure 9. Active DAS Configuration

Active DAS systems are available in many different configurations. The configuration presented in Figure 9 is a common type, where downlink signals from one or more RF sources are conditioned, combined and converted to light for distribution over fiber optic cables to radio units distributed throughout the venue. The radio units convert the optical inputs back to RF, amplify the signals and re-broadcast them through either integrated or external antennas to users inside the building. In the uplink direction, the process is reversed with the radio units converting received signals to light and transporting them back to the head-end equipment over fiber. In the head-end unit, the uplink signals are converted back to RF, separated by frequency and delivered to each operator's base station equipment. Active electronics containing gain elements in both the uplink and downlink directions are used in this configuration, hence the name "active DAS."

Like a passive DAS, sectorization is determined by hard wiring capacity from each signal source to head-end units which in turn feed specific radio units distributed throughout the building. In an active DAS, the RF and optical connections which determine sectorization are all located in the head-end equipment room. If sectorization changes are required after installation, the changes can be implemented at the DAS head-end with few physical changes to the DAS infrastructure distributed throughout the venue. Figure 9 is an illustration of a typical active DAS where one sector of capacity from two different signal sources provides coverage to two floors of a building.

## Active DAS

### Signal Sources

The same variety of signal sources used to feed a passive DAS can also be used to feed an active DAS. In the example shown in Figure 9, the repeater/BDA was omitted only to provide more room in the illustration to clearly show the components used in an active DAS. The ability to support multiple signal sources from multiple network equipment manufacturers (NEM) makes active DAS attractive for large venue, neutral host applications.

### Point-of-Interface (POI) Tray

Like a passive DAS, the main and diversity receive paths for each RF signal source may need to be combined to prevent diversity imbalance alarms. This is often accomplished using standalone hybrid combiners, as depicted in Figure 9, or can be incorporated inside a DAS Point-of-Interface (POI) tray.

Point-of-Interface (POI) trays are typically installed between each RF signal source and the DAS head-end unit to separate the uplink and downlink signals and to provide a means to attenuate the uplink signal prior to entering the head-end unit. In many cases, the signal sources used to feed a DAS are macro base stations. These high power signal sources must be attenuated from 40 W (46 dBm) or higher to 1 mW (0 dBm) before entering the head-end unit.

The POI tray may provide additional functionality as required by the application. This could include RF monitor ports for evaluating uplink and downlink signal levels while the DAS is operational. The POI may also include variable attenuation for the uplink path providing a means to attenuate noise power generated by the amplifiers in the system.

The RF connectors on the signal source side of the POI are usually heavy-duty, 7-16 DIN style connectors for low PIM performance. PIM is only a concern in an active DAS head-end in the high power region between the signal source and the common junction of the duplexer inside the POI. After the POI duplexer, any PIM generated in the DAS head-end is attenuated by the isolation of the duplexer (typically >60 dB) on its way back to the base station receiver and is unlikely to impact system performance. QMA or SMA style connectors are typically used on the low power head-end side of the POI where PIM is no longer a concern.



Figure 10. Point-of-Interface (POI) Tray

### Head-End Unit

Small diameter coaxial cables are used to connect the uplink and downlink ports from each POI to corresponding RF modules on the DAS head-end unit. These modules are band-specific and provide additional filtering and amplification to further condition each path. The uplink and downlink signals from each signal source serving a particular zone are combined and fed to separate RF-to optical converters; one for the uplink signals and one for the downlink signals. Multiple uplink and downlink optical connector pairs are provided at the head-end unit output, each pair supporting one radio unit in the venue.



## Active DAS

---

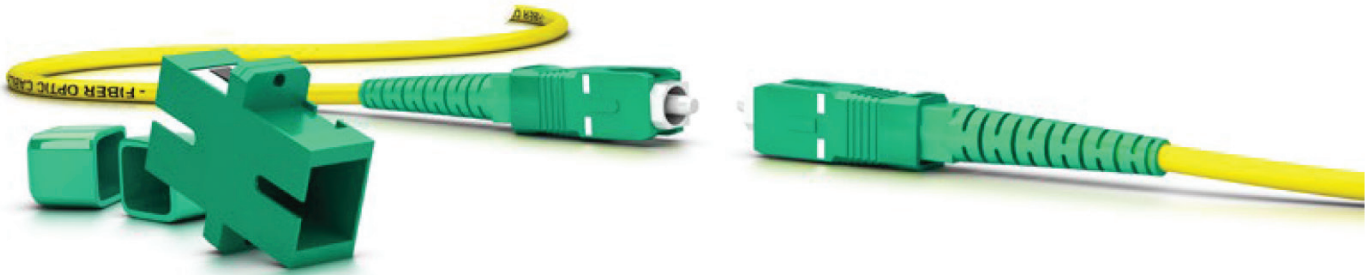

### Signal Distribution

Single Mode (SM) or Multi-Mode (MM) fiber optic cables can be used in an active DAS to transport uplink and downlink signals between the DAS head-end unit and the distributed radio units. Fiber optic cables are small, light-weight and flexible making them significantly easier to route through a building compared to larger, more rigid coaxial cables. Optical loss in fiber optic cables is significantly lower than RF loss in coaxial cables, enabling radio units to be placed long distances (multiple kilometers) away from the DAS head-end equipment without impacting link performance. Angle Polish Connectors (APC) are typically specified in active DAS to reduce optical return loss (ORL) and minimize optical loss at each connection.

Single mode optical transmitters and receivers operating at 1310 nm or 1550 nm are typically used for active DAS applications. Uplink and downlink may operate at different wavelengths on the same fiber, but more traditionally operate at the same wavelength on separate fibers, reducing the cost and complexity of the optical equipment. The laser light source is amplitude modulated using the same frequencies as the uplink and downlink signals, allowing the RF input to be transferred directly to light without frequency conversion or digitization. A single optical link is able to support the full range of commercial wireless frequency bands as well as a support a multitude of input waveforms, including GSM, CDMA, UMTS and LTE, without altering the input signals.

### Radio Units

Active DAS include radio units installed near each antenna location that convert the optical signals from the head-in unit back to RF, separate the signals by frequency, apply filtering, amplify the signals and direct the signals to antennas for broadcast. Different types of radio units are available based on the required transmit power and the number of frequency bands supported. AC or DC power must be supplied at each radio unit location and the location should be accessible for ongoing maintenance and repair.



One benefit of an active DAS over a passive DAS is that there are very low coaxial cable losses between the antenna and the receive amplifier inside the radio unit. The high cable losses experienced in a passive DAS prior to the NEM receiver add directly to the system noise figure. This requires mobiles operating inside a building with a passive DAS to increase transmit power to achieve an acceptable signal-to-noise ratio (SNR). In the active DAS, losses are greatly reduced meaning that mobiles inside the building are able to transmit at a much lower power levels (extending battery life) to achieve an equivalent SNR.

## Active DAS

### Antennas

Some radio units include an integrated antenna while others include an RF output port to feed external antennas. The same types of external antennas used in a passive DAS can also be used with an active DAS, providing maximum flexibility to the DAS designer to select antennas with optimum pattern shape for each installed location. External sources of passive intermodulation (PIM) are a concern around active DAS antennas just as they are around passive DAS antennas. PIM sources near the antenna will generate the same amount of PIM for a given radiated power level regardless of whether the RF signals originate in a nearby radio unit or originate in a NEM radio at the DAS head-end. The best practices recommended for selecting passive DAS antenna locations apply equally to active DAS antenna locations.

### MIMO Active DAS

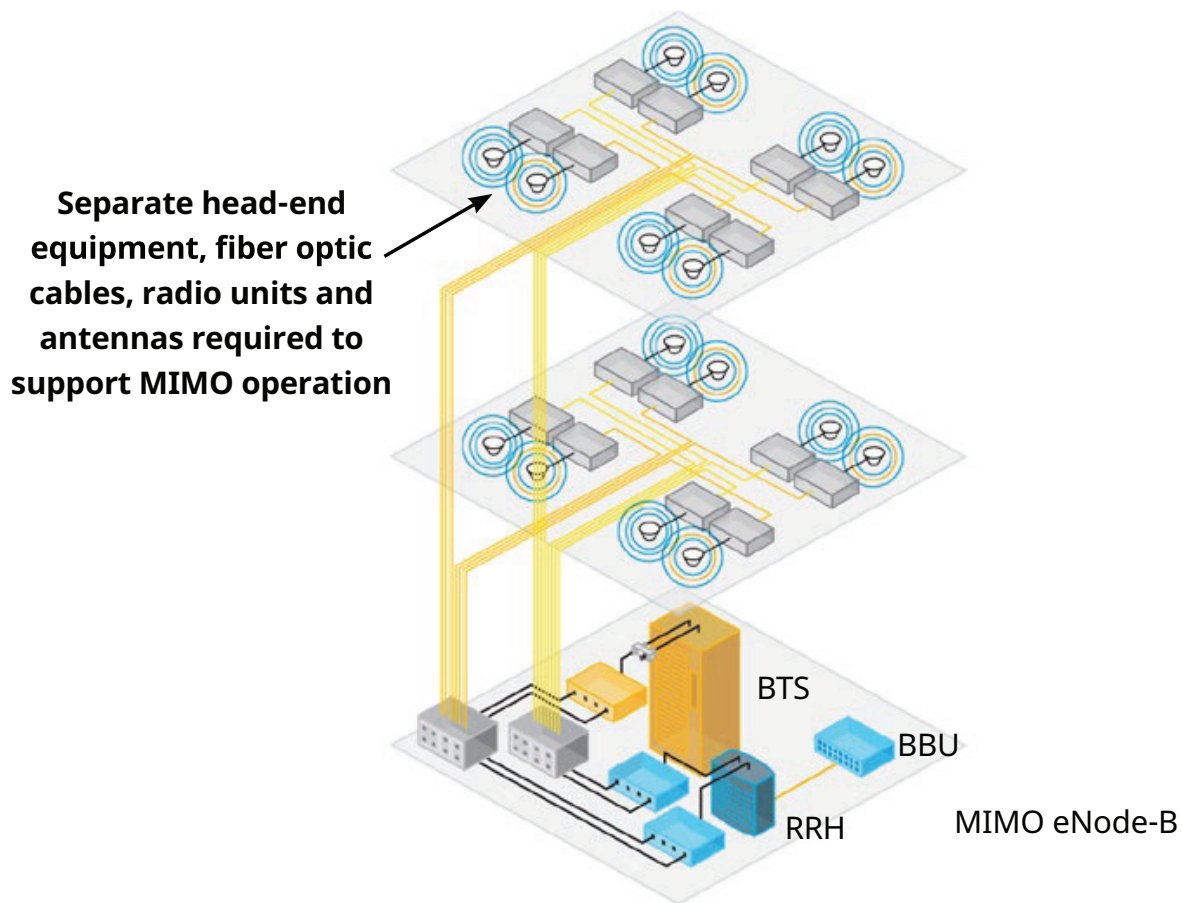

Figure 11. MIMO Active DAS Configuration

## Active DAS

---

To support MIMO operation in an active DAS, independent data streams are required between the mobile user and the network equipment manufacturer's MIMO base station. As shown in Figure 11, this would entail adding a separate POI and head-end unit as well as doubling the number of fiber optic cables, radio units and antennas distributed throughout the venue for each sector. The antenna requirements discussed in the MIMO passive DAS section apply equally to the MIMO active DAS.

While this is a significant increase in number of required components and looks very crowded in the 2-floor building illustration, MIMO active DAS is often the solution of choice for large venues such as stadiums or airports that must provide coverage and capacity to support multiple operators and multiple technologies.

### Active DAS Pros and Cons

Several of the benefits of an active DAS have already been discussed in the previous sections. These include easier cable routing, ability to locate the radio units a long distance from the head-end equipment room, ability to easily modify sectorization after installation and longer battery life for mobile users for any given SNR compared to a passive DAS.

Active DAS also provide the ability to fine tune radiated power levels by individual frequency band at each antenna location to optimize coverage and minimize interference. In addition, active DAS have the ability to monitor reflected power at the radio unit level to report damaged antennas anywhere in the system. Damaged antennas are not able to be detected in a passive DAS due to the high insertion loss between the NEM radio and individual antennas. The only way to identify damaged antennas in a passive system is to perform periodic walk tests with a spectrum analyzer to evaluate changes in coverage over time.

Another benefit of an active DAS is that fewer locations in the over-all signal path are able to generate passive intermodulation (PIM). This reduces the probability of PIM issues in the DAS and isolates PIM to specific locations within the system.

The most significant problem with an active DAS is cost. The bill of materials (BOM) cost to build an active DAS, including head-end units, POI's, and radio units is significantly higher than the BOM cost to build a passive DAS in many applications. Active DAS also require more floor space in the head-end equipment room to accommodate multiple POI's and multiple head end units. However, for complex venues or venues with large separation between zones of coverage, an active DAS may be the only technically feasible solution.

## Hybrid DAS

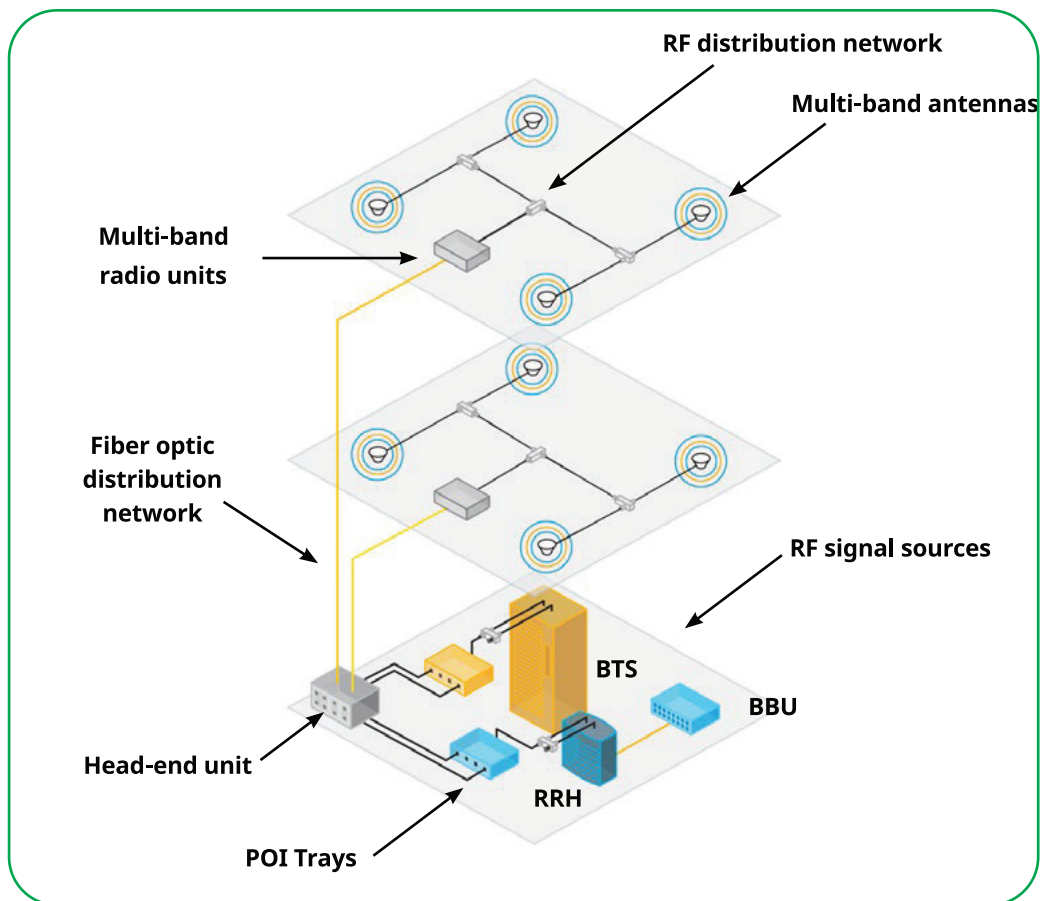

Figure 12. Hybrid DAS Configuration

To mitigate the high cost of a purely active DAS, hybrid configurations are often deployed. A hybrid DAS uses active components to transport signals from the head-end equipment room to zones of coverage and passive components to distribute the signal within each zone. Higher power radio units are required in a hybrid DAS configuration to overcome the loss of the passive network beyond the radio. Fewer of these radios are required, however, with fewer fiber optic cables to pull throughout the venue, providing lower overall cost. Figure 12 is an illustration of a hybrid DAS where one sector of capacity from two different signal sources provide coverage to two floors of a building.

## Hybrid DAS

---

### Hybrid DAS Pros and Cons

Hybrid DAS provide many of the same benefits as a purely active DAS such as easier long distance cable routing, ability to locate the radio units far away from the head-end equipment room and ability to easily modify sectorization after installation. Hybrid DAS also have the added benefit that radio units can be located in designated telecom equipment closets in each zone, with easy access to AC power and improved access for maintenance.

RF performance of a hybrid DAS is somewhere between that of an active DAS and a passive DAS. Design engineers will have less ability to fine tuning radiated power levels at each individual antenna compared to an active DAS, but since the cable lengths are shorter compared to a fully passive DAS, less power level variation will occur between high and low frequency bands. The loss of the passive network in front of the radio unit receiver will increase the system noise figure, causing mobiles to increase power to achieve an acceptable SNR. However, the noise figure impact will be less than that of a purely passive DAS.

Because the radio units are transmitting at higher power and because there are multiple RF connections between the radio unit and each antenna, passive intermodulation (PIM) is a higher concern in a hybrid DAS compared to an active DAS. Special plenum rated coaxial cables without foam between the center conductor and the outer conductor will likely be required for distributing the RF signal throughout each zone. These cables require an extra degree of skill during installation to properly prepare the cable ends and attach RF connectors to prevent PIM and prevent high RF reflections. As a result, installation costs at the floor level may increase compared to an active DAS.

Even with the limitations discussed, hybrid DAS often provide the best compromise between cost, performance and maintainability for multi-operator systems serving large / complex venues with changing coverage requirements.

## Digital DAS

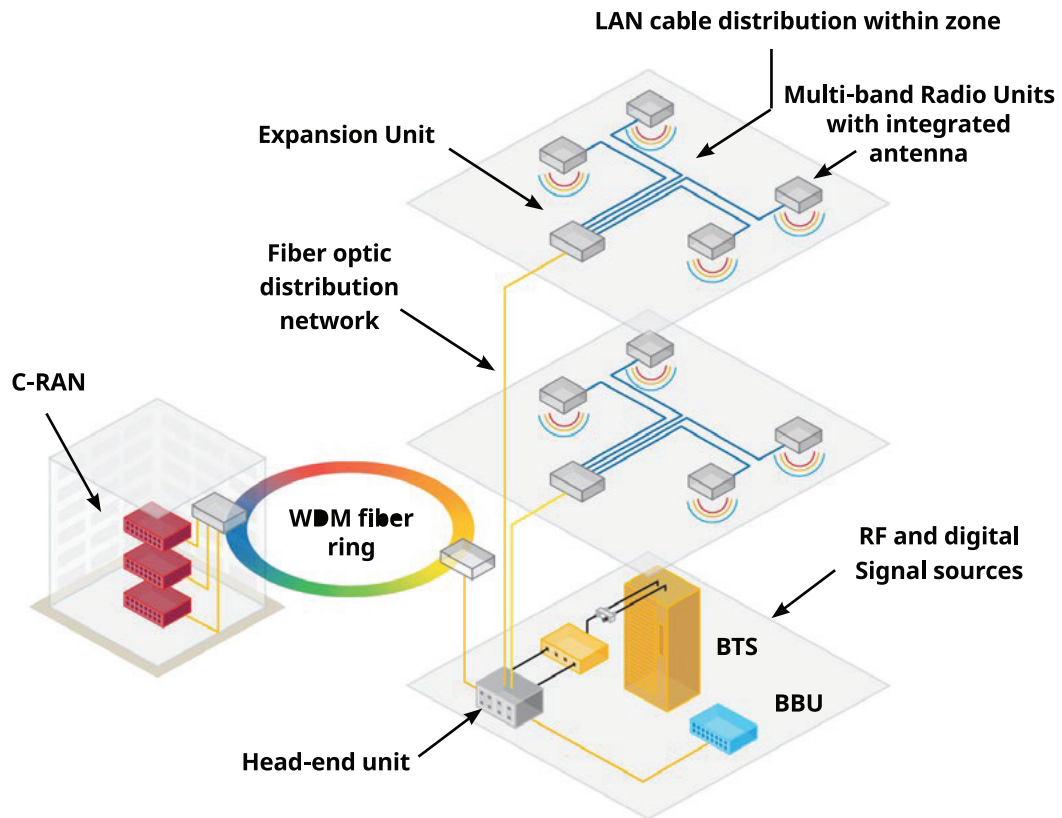

Figure 13. Digital DAS Configuration

There are only minor architectural differences between a Digital DAS and a Distributed Radio System (DRS), which will be introduced in the next section. Digital DAS utilize radios manufactured by the DAS equipment provider, not radios manufactured by the NEM. Digital DAS are also able to accept RF inputs from a variety of NEM base stations with centralized base band processing and centralized radio resources. Because of these attributes, digital DAS are characterized as a type of DAS rather than as a DRS. Figure 13 is an illustration of a typical digital DAS showing capacity from three different signal sources providing coverage to two floors of a building.

The key distinction between a digital DAS and an “analog” active DAS is that in a digital DAS the link between the head-end unit and the multiple radio units is digital rather than analog. Packets of digitized RF data from each signal source are time division multiplexed on the optical and/or electrical links. Common Public Radio Interface (CPRI) or other proprietary radio data interface protocols may be used for communications within the DAS. Because each packet contains a destination address, transmitted data can be routed to specific radio units, creating the ability to dynamically distribute capacity throughout the venue rather than relying on fixed resource assignments. Capacity assigned to office areas during the day might be reassigned to shopping areas at night. Capacity in a stadium might move from the outdoor “tailgating” area before the game to inside the venue as the people transition to their seats. Though not shown in the illustration, most digital DAS manufacturers provide a 1 GBit/s Ethernet port at each radio unit, enabling IP traffic (IP cameras, Wi-Fi, etc.) to be backhauled through the DAS cable infrastructure in addition to the RF packet data.

### Signal Sources

The same types of RF signal sources used to feed an active DAS as can also be used to feed a digital DAS. As shown in the illustration, each RF signal source requires a hybrid combiner to combine the main and diversity receive paths and a POI tray to separate the uplink and downlink signals and enable level adjustment. This combining and conditioning equipment is no different than that required for RF signal sources feeding an active DAS.

In addition to RF signal sources, the possibility exists to feed the digital DAS with digital signal sources. In this case, the Remote Radio Heads (RRH) and POI trays are eliminated, allowing the NEM's BBUs to connect directly to the head-end unit. Eliminating these components not only saves space in the head-end equipment room, but also significantly reduces ongoing energy requirements. Power is no longer needed to drive the RF amplifiers in the RRH and, with this RF power no longer being attenuated in the POI, less HVAC power is required to cool the head-end equipment.

Centralized radio access network (C-RAN) is possible with any DAS configuration, but is particularly compelling with digital DAS due to its ability to dynamically distribute resources within the venue. With C-RAN, base band resources are pooled in one location and shared between multiple indoor as well as multiple outdoor DAS nodes. This approach requires high capacity, low latency, low jitter "front haul" connections between the BBU's and the distributed DAS nodes. This can be accomplished by direct fiber connection when dark fiber is available or wave division multiplex (WDM) fiber links if fiber resources are limited.

### Head-end unit

Head-end units in a digital DAS are very similar to head-end units in an active DAS with the exception that all input signals (RF or digital) are converted to the DAS equipment manufacturer's digital transport protocol prior to distribution. The digital DAS head-end unit may support optical inputs for direct connection from digital signal sources in addition to RF inputs for connections from "conditioned" RF signal sources. The head-end unit of a digital DAS may also include an Ethernet connection to allow IP traffic to be multiplexed onto the same cable infrastructure used to distribute the RF packet data.

### Signal Distribution

Single Mode (SM) fiber optic cables are typically used in a digital DAS in the fronthaul link between the DAS head-end unit and distributed expansion units. Fiber optic cables are easy to route through the venue and have low optical loss, enabling the expansion units to be placed long distances (multiple kilometers) away from the DAS head-end equipment. The lasers used in digital DAS are switching between high and low amplitude states (1's and 0's) rather than modulating the RF input signal. The signal-to-noise (SNR) of this digital signal is significantly higher than SNR of the "analog" signals transmitted in a traditional active DAS. The higher SNR allows lower power lasers to be deployed and higher optical losses to be tolerated.

Expansion units in each zone convert the optical signal from the head-end equipment to electrical signals and transfer these signals to multiple radio units in that zone via CAT6A local area network (LAN) cables. The DC power required by each radio unit is supplied from the expansion unit over the LAN cables, eliminating the need to supply power at each antenna location. Expansion units can be located in designated telecom equipment closets in each zone, with easy access to AC power and improved access for maintenance.

## Digital DAS

---

### Radio Unit/Antenna

Digital DAS radio units accept the digital input from the expansion unit, convert this signal to RF and radiate the signals through an integrated wide band antenna. The radio units vary in frequency bandwidth by manufacturer but typically are able to support both high and low frequency band operators in a given market. An RF output port is typically included for feeding an external wideband antenna and an Ethernet connector may also be provided for supporting an external Wi-Fi access point.

The LAN cables used to deliver power to each radio are current limited, which in turn limits the maximum RF power that can be generated at each antenna location. Typically, these power-over-Ethernet (PoE) radio units are limited to approximately 250 mW (24 dBm) aggregate RF power. These radio units are best suited for DAS applications supporting a small number of operating bands (4 or fewer) with no anticipated need for additional bands or operators in the future. High power radio units are available from most digital DAS manufacturers with physical configurations similar to the traditional active DAS. In this case, AC or DC power is provided locally to enable higher aggregate RF power.



*Commscope ION-E Universal Access Point*

### Digital DAS Pros and Cons

Digital DAS offer the same advantages as an active DAS including the ability locate radio units a long distance from the head-end equipment room, ability to fine tune power levels for optimum coverage and the ability to support multiple-operator/multiple-NEM applications. Digital DAS offer the added ability to dynamically steer capacity from one zone to another as needs change as well as the ability to multiplex IP traffic onto the same cable infrastructure.

Digital DAS are able to tolerate significantly higher optical losses than analog DAS due to the improved SNR on the optical link. This may reduce cost by enabling a digital DAS to utilize the existing “house fiber”, rather than requiring dedicated fiber optic cables to be pulled throughout the venue.

In cases where the DAS equipment manufacturer and the NEM cooperate to enable direct digital feed between the NEM base band units (BBU) and the DAS head-end equipment, significant space, power and cost savings are possible. In addition, passive intermodulation (PIM) in a digitally fed DAS is greatly reduced, with external PIM sources around each antenna being the only remaining area of concern.

There are a few negative attributes of digital DAS that need to be taken into consideration. In order to time division multiplex digital signals, some bandwidth is lost to the overhead required to identify, synchronize and correctly route each packet. Even with this loss of bandwidth, systems available today typically support >200 MHz of total bandwidth, which is sufficient for most multi-band/multi-operator scenarios.

For cases where the NEM and DAS equipment manufacturer have cooperated to enable direct digital feed to the DAS head-end equipment, ongoing testing is required to ensure interoperability. Even if both manufacturers use CPRI as their communications protocol, this does not ensure that the two systems will work together. Firmware changes made by either manufacturer may cause unexpected problems that impact network performance to one or more operators until problem is isolated and resolved.

## Distributed Radio Systems (DRS)

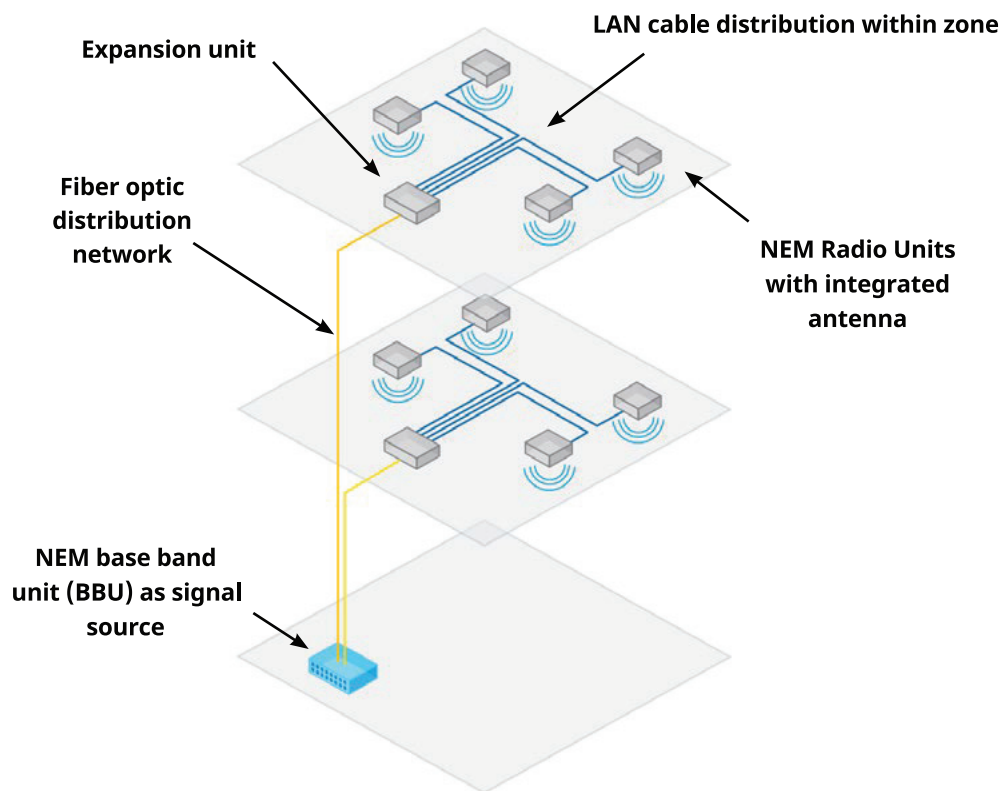

Figure 14. Distributed Radio System (DRS) Configuration

In a Distributed Radio System (DRS), the NEM base band processing is located in a central location and the NEM radio resources are distributed. This configuration is virtually identical to the digital DAS described in the previous section, with the notable exception that DRS utilize a single NEM's equipment throughout and support only one operator on the system. Initial DRS equipment supported only one frequency band, but advances have been made enabling multi-band/multi-technology DRS. The Ericsson DOT and Hauwei LampSite solutions are examples of DRS in use by network operators around the world. Figure 14 is an illustration of a typical DRS showing capacity from one signal source providing coverage to two floors of a building.

## Distributed Radio Systems (DRS)

---



*Ericsson DOT Distributed Radio System*

### **DRS Pros and Cons**

DRS offer the same advantages described in the digital DAS section with the exception that DRS are not multi-operator/multi-NEM solutions. DRS are typically used for enterprise applications where single operator deployments are the norm or for applications where the building owner will tolerate separate systems from each operator.

DRS eliminate all interoperability concerns since there is no conversion from one manufacturer's digital protocol to another. DRS are often perceived as a "safe" solution by operators since all equipment is provided by their existing macro network equipment provider. No new radio access network (RAN) equipment suppliers are required with these systems. This, however, can also be a limitation in that operators are not able to deploy a particular NEM's DRS solution if they do not utilize that same NEM for their macro network.

## Distributed Small Cells (DSC)

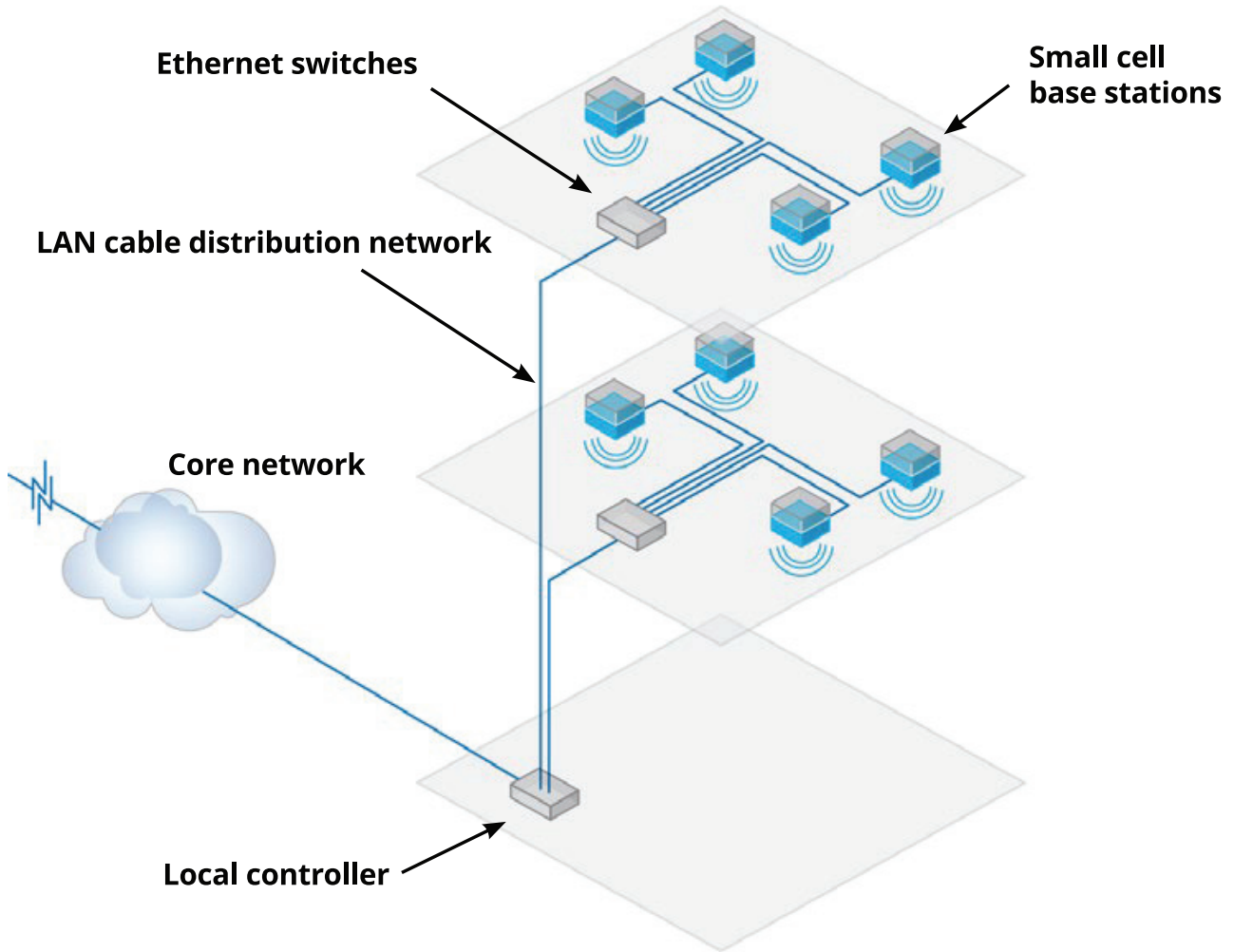

Figure 15. Distributed Small Cell (DSC) Configuration

In a Distributed Small Cell (DSC) system, the NEM base band processing and radio resources are distributed throughout the facility using small cell base stations. Each small cell is a fully functioning “pico” sized base station with integrated antenna and, in some cases, integrated Wi-Fi access point. DSC utilize standard CAT5/CAT6 local area network (LAN) cables and Ethernet switches to aggregate backhaul from the multiple small cells distributed throughout a building. The local controller coordinates the small cells within the venue and presents the group as a single cell ID to the operator’s core network. Additional functions of the local controller are vendor specific but may include features that automate set-up, mitigate intercell interference and facilitate local 3G soft hand-off. Figure 15 is an illustration of a typical DSC showing eight small cells providing coverage to two floors of a building.

## Distributed Small Cells (DSC)

---



*SpiderCloud Distributed Small Cell System*

### DSC Pros and Cons

DSC are primarily single-operator solutions supporting one or two frequency bands per small cell. Most systems are able to support 3G as well as 4G technology, while some only support 4G technology. DSC are well suited for enterprise applications where single operator deployments are the norm and where combined LAN plus cellular communications on the same cable infrastructure is highly valued.

Deploying a DSC is very similar to deploying Wi-Fi access points. Low cost twisted pair LAN cables and are used for connectivity between the local controller, Ethernet switches and individual small cells. Power for each small cell is typically delivered over the LAN cable from the Ethernet switch. Installations can be completed quickly and inexpensively using teams with structured cable installation skills rather than RF or optical cable assembly experience.

Adding additional small cells to the network to extend coverage is simple. Most systems have adopted SON (self organizing network) capability to enable each small cell to be automatically detected and provisioned once connected to the network.

Passive intermodulation is virtually eliminated as a concern in DSC due to the lack of RF cabling, limited frequency combinations (single operator) and the very low transmit power levels (<250 mW) present at each small cell radio.

DSC solutions connect directly to the operator's core network through a security gateway using the luh and  $S_1$  interfaces. Non-traditional RAN vendors are gaining market share in the DSC space (Cisco, SpiderCloud, Airvana, ip.access, etc.) In order to utilize a DSC solution from one of these vendors, the network operator must be willing to introduce of a new RAN equipment vendor into their portfolio and coordinate access to the core network.

## Summary

---

Distributed Antenna Systems (DAS), Distributed Radio Systems (DRS) and Distributed Small Cells (DSC) are three different architectures available for achieving in-building wireless (IBW) coverage and capacity. What makes each group distinctive is the physical location of the network equipment manufacturer (NEM) base band processing and radio resources. Factors such as cost, size of the venue and number of operators to be supported will have a significant impact on which architecture an operator chooses to deploy. There is no “one-size-fits-all” solution that is best for every application. As a result, operators will deploy multiple IBW architectures throughout their network to meet the growing demand for in-building wireless services.

### Anritsu Test Solutions for Optimum In-Building Wireless Performance

Anritsu offers a wide range of handheld test and measurement solutions to ensure optimum IBW performance, regardless of the configuration selected. Solutions are available for RF cable testing, optical cable testing, RF signal testing and optical transport testing. As the line between the Radio Access Network (RAN) and the Core Network becomes increasingly blurred, it is important to team with a test and measurement partner that understands all aspects of today’s ever changing mobile network technology.



#### Cable and Antenna Analyzers

- Individual component Return Loss/VSWR
- System/branch Return Loss/VSWR
- RF cable loss/cable length
- Distance-to-Fault (DTF) to identify fault locations
- 2-port options for repeater isolation measurements
- Power meter option for branch loss measurements



#### Passive Intermodulation (PIM) Analyzers

- Individual component Passive Intermodulation (PIM)
- System/branch level Passive Intermodulation (PIM)
- Low power capability for antenna location testing
- Distance-to-PIM (DTP) to identify PIM source locations

## Summary

---



### Spectrum Monitoring

- Monitor and analyze RF spectrum while events are in process
- Multi-port versions available for monitoring multiple sectors
- Indoor as well as outdoor solutions available



### Spectrum Analyzers

- Pre-installation walk test to evaluate existing signal levels
- Post installation walk tests to verify coverage
- Tx/Rx path leveling
- Interference analysis



### Land Mobile Radio (LMR) Analyzers

- Integrated 2-port Cable & Antenna analyzer
- Integrated Spectrum Analyzer
- P25, TETRA signal demodulation to evaluate signal quality



### Video Inspection Microscopes

- Verify optical interfaces are free of dirt, oil, and defects
- Automatic pass/fail determination based on IEC 61300-3-35
- Works with Anritsu OTDRs or Windows tablets & computers
- PDF summary report provides installation documentation



### Optical Light Source/Optical Power Meter

- Cost effective way to measure optical transmission loss
- Verify total optical loss is within loss budget
- Supports wide variety of wavelengths and connector types

### Visual Fault Locators

- Easily isolate high losses and faults in optical fiber cable with handheld visible laser source

### Optical Fiber Identifiers

- Identify live fibers safely and nonintrusively. Prevents costly mistakes by avoiding accidental disruption of service on active data links

## Summary

---



### **Multi-Function Optical Time Domain Reflectometers (OTDR)**

- Evaluate quality of individual optical connections and splices
- Locate fiber breaks and macro bends
- Measure fiber length/optical loss
- Measure optical return loss and individual connector reflectance
- Integrated visual light source to verify connectivity
- Integrated optical power meter
- User friendly GUI to simplify fiber installation & maintenance



### **Optical Transport Analyzers**

- Synchronous Ethernet backhaul testing (SyncE, PTP)
- Industry standard service assurance testing
- C-RAN Fronthaul testing (CPRI, OBSAI)
- Confirm connectivity, verify correct SFP modules are installed
- Delay/Bit Error Rate (BER) measurements
- Comprehensive optical transport network (OTN) testing
- OTDR measurement capability as described above
- Solve network problems quickly to reduce downtime

## Anritsu's Industry Leading Training Services

---

Anritsu offers a variety of professional training programs that teach students both the theoretical background as well as the practical skills needed to properly test and troubleshoot in-building wireless systems. Both on-line as well as instructor-led certification training classes are available covering a variety of subjects.

- Passive DAS Certification
- Active DAS Certification
- Site Master Line Sweep Certification
- PIM Master Certification
- Fiber Optic & OTDR Certification
- RF & Microwave Interference Analysis Certification

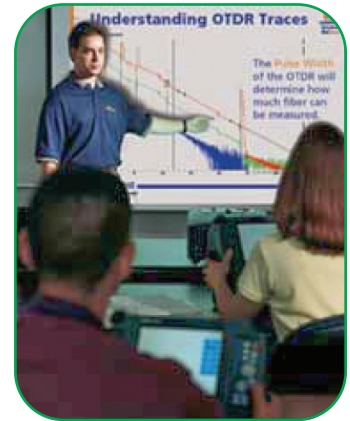

Contact your local Anritsu sales office for more information on training opportunities. See the back cover of this document for regional office details.

• **United States**

**Anritsu Americas Sales Company**

450 Century Parkway, Suite 190, Allen, TX 75013 U.S.A.  
Phone: +1-800-Anritsu (1-800-267-4878)

• **Canada**

**Anritsu Electronics Ltd.**

**Americas Sales and Support**

450 Century Parkway, Suite 190, Allen, TX 75013 U.S.A.  
Phone: +1-800-Anritsu (1-800-267-4878)

• **Brazil**

**Anritsu Eletronica Ltda.**

Praça Amadeu Amaral, 27 - 1 Andar  
01327-010 - Bela Vista - Sao Paulo - SP, Brazil  
Phone: +55-11-3283-2511  
Fax: +55-11-3288-6940

• **Mexico**

**Anritsu Company, S.A. de C.V.**

Blvd Miguel de Cervantes Saavedra #169 Piso 1, Col. Granada  
Mexico, Ciudad de Mexico, 11520, MEXICO  
Phone: +52-55-4169-7104

• **United Kingdom**

**Anritsu EMEA Ltd.**

200 Capability Green, Luton, Bedfordshire, LU1 3LU, U.K.  
Phone: +44-1582-433200  
Fax: +44-1582-731303

• **France**

**Anritsu S.A.**

12 avenue du Québec, Immeuble Goyave,  
91140 VILLEBON SUR YVETTE, France  
Phone: +33-1-60-92-15-50

• **Germany**

**Anritsu GmbH**

Nemetschek Haus, Konrad-Zuse-Platz 1,  
81829 München, Germany  
Phone: +49-89-442308-0  
Fax: +49-89-442308-55

• **Italy**

**Anritsu S.r.l.**

Spaces Eur Arte, Viale dell'Arte 25, 00144 Roma, Italy  
Phone: +39-6-509-9711

• **Sweden**

**Anritsu AB**

Kistagången 20 B, 2 tr, 164 40 Kista, Sweden  
Phone: +46-8-534-707-00

• **Finland**

**Anritsu AB**

Technopolis Aviapolis, Teknobulevardi 3-5 (D208.5),  
FI-01530 Vantaa, Finland  
Phone: +358-20-741-8100

• **Denmark**

**Anritsu A/S**

c/o Regus Winghouse, Ørestads Boulevard 73, 4th floor,  
2300 Copenhagen S, Denmark  
Phone: +45-7211-2200

• **Spain**

**Anritsu EMEA Ltd.**

**Representation Office in Spain**

Paseo de la Castellana, 141. Planta 5, Edificio Cuzco IV  
28046, Madrid, Spain  
Phone: +34-91-572-6761

• **Austria**

**Anritsu EMEA GmbH**

Am Belvedere 10, A-1100 Vienna, Austria  
Phone: +43-(0)1-717-28-710

• **United Arab Emirates**

**Anritsu EMEA Ltd.**

**Anritsu A/S**

Office No. 164, Building 17, Dubai Internet City  
P. O. Box – 501901, Dubai, United Arab Emirates  
Phone: +971-4-3758479

• **India**

**Anritsu India Private Limited**

6th Floor, Indiqueb ETA, No.38/4, Adjacent to EMC2,  
Doddanekundi, Outer Ring Road, Bengaluru – 560048, India  
Phone: +91-80-6728-1300  
Fax: +91-80-6728-1301

• **Singapore**

**Anritsu Pte. Ltd.**

11 Chang Charn Road, #04-01, Shriro House, Singapore 159640  
Phone: +65-6282-2400  
Fax: +65-6282-2533

• **Vietnam**

**Anritsu Company Limited**

16th Floor, Peakview Tower, 36 Hoang Cau Street, O Cho Dua Ward,  
Dong Da District, Hanoi, Vietnam  
Phone: +84-24-3201-2730

• **P.R. China (Shanghai)**

**Anritsu (China) Co., Ltd.**

Room 2701-2705, Tower A, New Caohejing International  
Business Center No. 391 Gui Ping Road Shanghai, 200233, P.R. China  
Phone: +86-21-6237-0898  
Fax: +86-21-6237-0899

• **P.R. China (Hong Kong)**

**Anritsu Company Ltd.**

Unit 1006-7, 10/F., Greenfield Tower, Concordia Plaza,  
No. 1 Science Museum Road, Tsim Sha Tsui East,  
Kowloon, Hong Kong, P.R. China  
Phone: +852-2301-4980  
Fax: +852-2301-3545

• **Japan**

**Anritsu Corporation**

8-5, Tamura-cho, Atsugi-shi, Kanagawa, 243-0016 Japan  
Phone: +81-46-296-6509  
Fax: +81-46-225-8352

• **Korea**

**Anritsu Corporation, Ltd.**

5FL, 235 Pangyojeok-ro, Bundang-gu, Seongnam-si,  
Gyeonggi-do, 13494 Korea  
Phone: +82-31-696-7750  
Fax: +82-31-696-7751

• **Australia**

**Anritsu Pty. Ltd.**

Unit 20, 21-35 Ricketts Road, Mount Waverley, Victoria 3149, Australia  
Phone: +61-3-9558-8177  
Fax: +61-3-9558-8255

• **Taiwan**

**Anritsu Company Inc.**

7F, No. 316, Sec. 1, NeiHu Rd., Taipei 114, Taiwan  
Phone: +886-2-8751-1816  
Fax: +886-2-8751-1817

List Revision Date: 20230407



Anritsu utilizes recycled paper and environmentally conscious inks and toner.



© Anritsu All trademarks are registered trademarks of their respective owners. Data subject to change without notice. For the most recent specifications visit: [www.anritsu.com](http://www.anritsu.com)

11410-00885 Rev. D Printed in United States 2023-06  
©2023 Anritsu Company. All Rights Reserved.