

1

2

3

4

ZONE	REV	DESCRIPTION OF REVISION	ECN NO.	BY	DATE	APPROVED
	A	INITIAL ISSUE	N/A	EC	08/04	AT

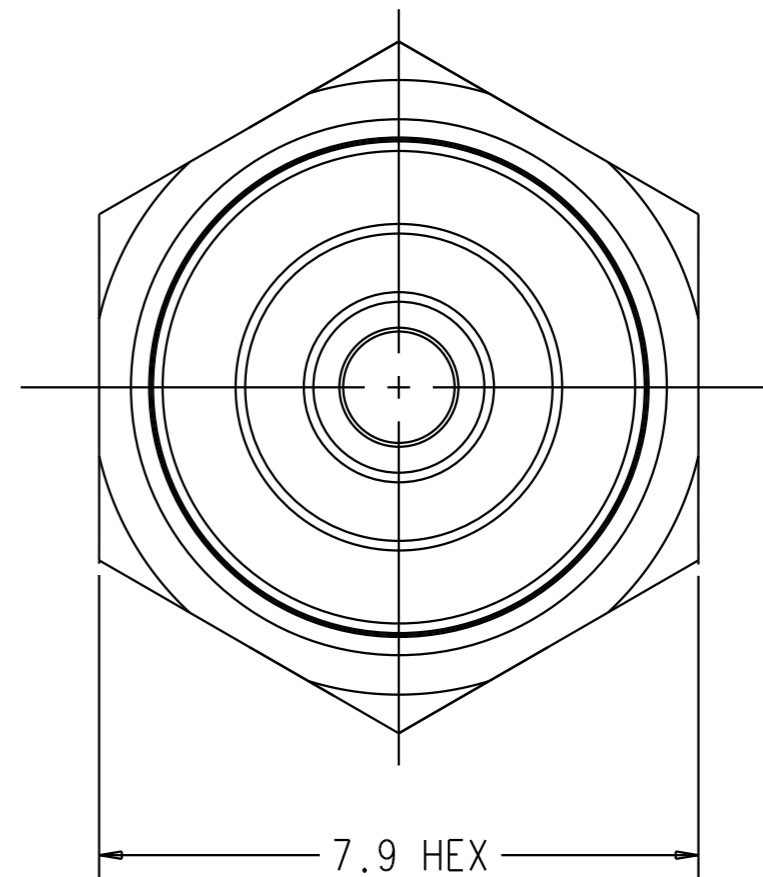
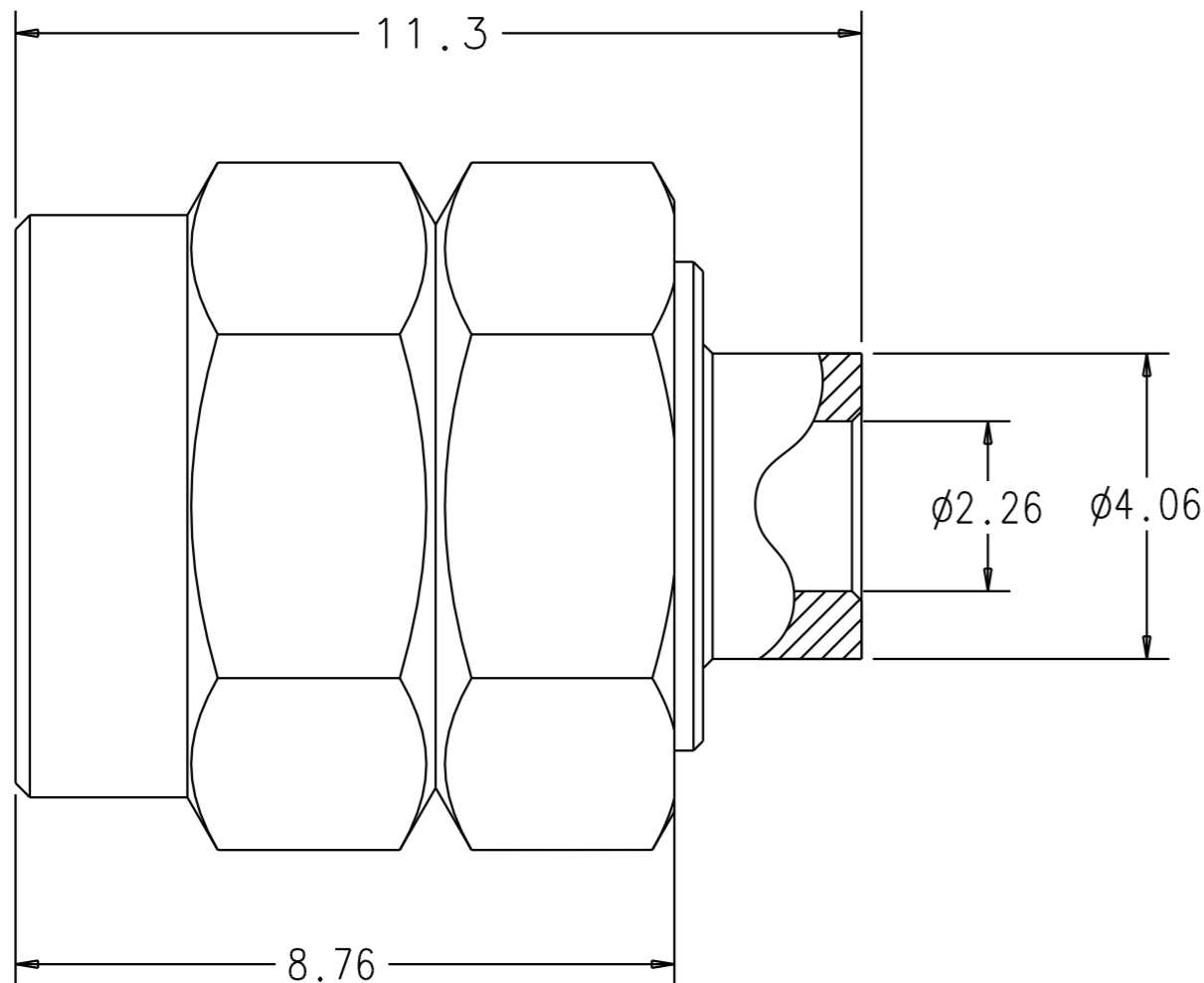

NOTES:

- 1. ELECTRICAL
 - 1.1. FREQUENCY RANGE:DC TO 65 GHz
 - 1.2. VSWR:1.58
- 2. MECHANICAL
 - 2.1. FRONT-SIDE PIN DEPTH:0.000 TO -0.130
 - 2.2. COUPLING NUT TIGHTENING TORQUE:1.36N-. MAX
- 3. OPERATING TEMPERATURE:-55°C TO +125°C
- 4. ENVIRONMENTAL
 - 4.1. TEMPERATURE SHOCK:25°C TO -55°C AND 25°C TO +125°C, METHOD 107G, CONDITION B
 - 4.2. MECHANICAL SHOCK:100G_{peak} SAWTOOTH, METHOD 213, TEST CONDITION I
 - 4.2. HUMIDITY:95% AT 40°C, 96 HOURS, TEST 103B, CONDITION B
 - 4.3. VIBRATION=SINWAVE:10Hz TO 2000Hz, 0.06*DA, METHOD 204, TEST CONDITION D
RANDOM:50Hz TO 2000Hz, 11.6 Grms, Pwr SPECTRAL DENSITY 0.1Grms²/Hz, METHOD 214, TEST CONDITION I LETTER D
 - 4.4. SALT SPRAY:5% CONCENTRATION FOR 48 HOURS, METHOD 101D, CONDITION B
 - 4.5. VOLTAGE WITHSTANDING:500Vac RMS, 60 SECONDS, METHOD 301
- 5. MATERIALS:
 - 5.1. OUTER CONDUCTOR:BeCu COPPER, GOLD PLATED OVER NICKEL
 - 5.2. COUPLING NUT:STAINLESS STEEL

DIMENSIONS ARE FOR REFERENCE ONLY

UNLESS OTHERWISE SPECIFIED, ALL DIMENSIONS ARE IN MILLIMETERS (mm)	DRAWN	E. CHEN	DATE	02/04	MATERIAL: SEE SEPARATE PRODUCT STRUCTURE	
	CHECKED	A. SHARMA	DATE	08/04	490 JARVIS DRIVE MORGAN HILL, CA. 95037	
	APPROVED	A. THOMAS	DATE	08/04		
	SEE PRODUCT STRUCTURE	TOLERANCES: UNLESS OTHERWISE SPECIFIED		TITLE		
ALL INFORMATION SHOWN ON THIS SPECIFICATION IS PROPRIETARY INFORMATION OF ANRITSU COMPANY	1 PLACES	ANGLES	V101M			
	2 PLACES	SURFACE FINISH <input checked="" type="checkbox"/> N7	V MALE IN-LINE CABLE CONNECTOR OUTLINE			
	3 PLACES		FSCM NO. 20944		DRAWING NO. 63330	REV A
FINISH	N/A		SCALE	1/X		
DO NOT SCALE DRAWING			UNDER ECN CONTROL 08/04 BY GM DATE M,E		SHEET 1 OF 1	