

# MAINTENANCE MANUAL

## Site Master™ Model S251C

### Antenna and Cable Analyzer



**Figure 1.** Site Master Model S251C

## 1. INTRODUCTION

This manual provides maintenance instructions for the Site Master S251C Antenna and Cable Analyzer. It describes the product and provides performance verification procedures, parts replacement procedures, and a replaceable parts list.

## 2. DESCRIPTION

The Site Master (Figure 1) is a hand held S<sub>21</sub> (transmission gain or loss), SWR/RL (standing wave ratio/return loss), and Distance-To-Fault measurement instrument. It combines a synthesized source, VSWR Bridge, and receiver on a single printed circuit board (PCB). An optional power monitor is also available. A block diagram is shown in Figure 2.

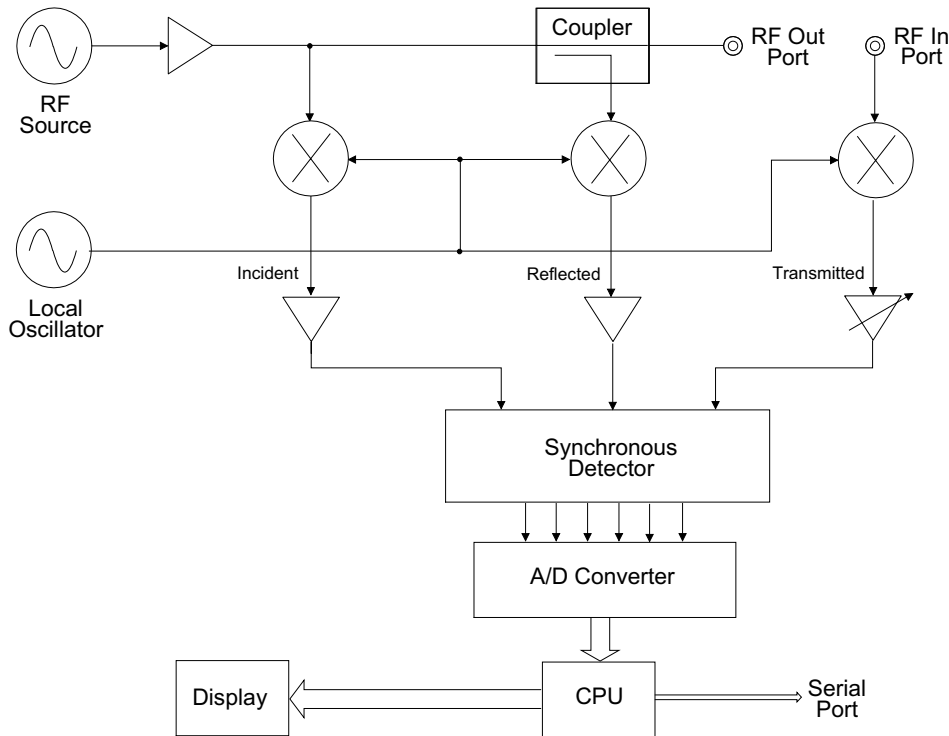
## 3. PERFORMANCE VERIFICATION

Paragraphs 4 through 10 contain tests that can be used to verify the performance of the Site Master model S251C having any version of firmware.

### 3.1. Initial Setup for Testing

1. Press and hold the **ESCAPE/CLEAR** key, then press the **ON/OFF** key to turn on the Site Master. (This sets the instrument to the factory preset state.)
2. If necessary, use the Up/Down arrow key to adjust the contrast to give a readable display. Press **ENTER** to accept.

# Anritsu



**Figure 2.** Site Master Block Diagram

#### 4. FREQUENCY ACCURACY

The following test can be used to verify the CW frequency accuracy of the Site Master. Measurement calibration of the Site Master is *not* required for this test.

##### a. Equipment Required:

- Spectrum Analyzer  
Anritsu Model MS2668C or equivalent

##### b. Procedure:

1. Press and hold the **ESCAPE/CLEAR** key, then press the **ON/OFF** key to turn on the Site Master. (This sets the instrument to the factory preset state.)

##### **NOTE**

Before continuing, allow a five minute warm up for the internal circuitry to stabilize.

2. Press the **MODE** key.
3. Use the Up/Down Arrow key to highlight **RF SOURCE**, then press **ENTER**.
4. Press the **FREQ** soft key.

5. Using the keypad or Up/Down Arrow key enter 1000.0 MHz then press the **ENTER** key.
6. Connect the RF cable from the Site Master RF Out Test Port to the RF Input on the Spectrum Analyzer.
7. Set up the Spectrum Analyzer as follows:
  - (a) Press **Preset**
  - (b) Press the **PRESET ALL** soft key
  - (c) Press **Frequency** and enter 1 GHz
  - (d) Press **Span** and enter 200 kHz
  - (e) Press **Amplitude**
  - (f) Press the **REFERENCE LEVEL** soft key and enter 10 dB
8. If the Site Master has gone into the hold mode, press the **RUN/HOLD** key to make the measurement.
9. On the Spectrum Analyzer:
  - (a) Press **Marker**
  - (b) Press **PEAK SEARCH**. The frequency should be 1000 MHz  $\pm$ 75 kHz.

## 5. TRANSMISSION/ISOLATION VERIFICATION

The following test can be used to verify transmission test port isolation and the accuracy of transmission measurements. Measurement calibration of the Site Master is required for this test.

### a. Equipment Required:

- 10 dB Attenuator, Weinshel 1-10
- 30 dB Attenuator, Weinshel 1-30
- Open/Short, Anritsu 22NF50
- 50 Ohm Terminations, Anritsu SM/PL or 28N50-2  
Anritsu SM/PLNF or 28NF50-2
- Armored Test Port Extension Cable, 1.5 Meter, N(m) to N(m), Anritsu 15NN50-1.5A

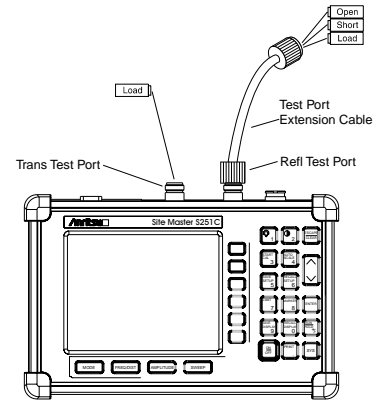
### b. Procedure:

1. Press and hold the **ESCAPE/CLEAR** key, then press the **ON/OFF** key to turn on the Site Master. (This sets the instrument to the factory preset state.)

#### NOTE

Before continuing, allow a five minute warm up for the internal circuitry to stabilize.

2. Press the **MODE** key.
3. Use the Up/Down Arrow key to highlight **INSERTION LOSS**, then press **ENTER**.
4. Press the **AMPLITUDE** key.
5. Press the **TOP** soft key.
6. On the keypad, press "0", then press **ENTER**. (Verify the bottom limit is set to -120 dB.)
7. Press the **LIMIT** key.
8. Press the **SINGLE LIMIT** soft key.
9. Press the **EDIT** soft key, enter -80, and press the **ENTER** key.
10. Press the **START CAL** key.
11. Follow the instructions on the display to perform a OSL-THRU-ISOL calibration using a 22NF50 Open/Short, 28NF50-2 or SM/PLNF Terminations, and 15NN50-1.5A Test Port Extension Cable (refer to Figure 3).



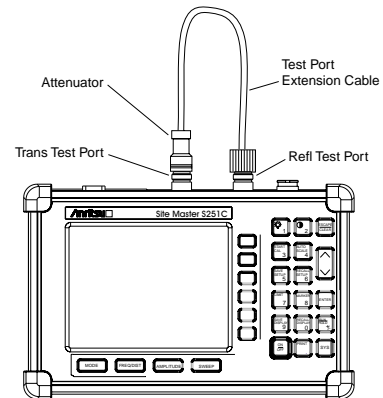
**Figure 3.** OSL-THRU-ISOL Calibration Setup

12. Connect a Load (28N50-2 or SM/PL) to the RF In Test Port and verify that the noise floor (isolation) is below -80 dB.
13. Press the **MARKER** key.
14. Press the **M1** soft key, then the **EDIT** soft key.
15. Using the keypad or the Up/Down Arrow key, enter 1000.0 MHz, and press **ENTER**.

#### NOTE

For the following steps in the procedure, use **only** attenuators that have Type N connectors. The use of attenuators with other type connectors and adapters will cause measurement errors.

16. Connect the 10 dB attenuator to the RF In Test Port (refer to Figure 4) and verify that the reading is -10 dB  $\pm$  2.25 dB @ 1000 MHz.
17. Connect the 10 dB and 30 dB attenuators in series to the RF In Test Port and verify that the reading is -40 dB  $\pm$  3.25 dB @ 1000 MHz.



**Figure 4.** Test Setup

## 6. RETURN LOSS VERIFICATION

The following test can be used to verify the accuracy of return loss measurements. Measurement calibration of the Site Master is required for this test.

### a. Equipment Required:

- 20 dB offset, Anritsu SC5270
- 6 dB offset, Anritsu SC5237
- Open/Short, Anritsu 22N50
- 50 Ohm Termination, Anritsu 28N50-2 or SM/PL

### b. Procedure:

1. Press and hold the **ESCAPE/CLEAR** key, then press the **ON/OFF** key to turn on the Site Master. (This sets the instrument to the factory preset state.)

#### **NOTE**

Before continuing, allow a five minute warm up for the internal circuitry to stabilize

2. Press the **MODE** key.
3. Use the Up/Down Arrow key to highlight **RETURN LOSS**, then press **ENTER**.
4. Press the **START CAL** key.

5. Follow the instructions on the screen to perform a calibration using a 22N50 Open/Short and 28N50-2 or SM/PL Termination.

6. Connect the 20 dB offset to the RF Out Test Port and verify that the reading is 20 dB  $\pm 1.7$  dB

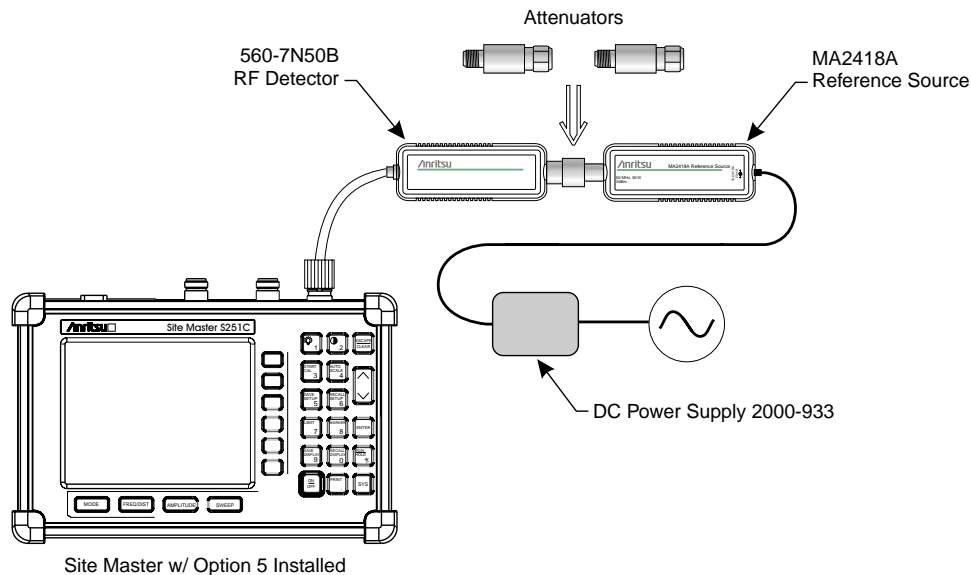
7. Connect the 6 dB offset to the RF Out Test Port and verify that the reading is 6 dB  $\pm 1.2$  dB

## 7. POWER MONITOR VERIFICATION

If the Power Monitor (Option 5) is installed in the Site Master, the following test can be used to verify the accuracy of the power measurements. Measurement calibration of the Site Master is **not** required for this test.

### a. Equipment Required:

- RF Detector, 10 MHz to 20 GHz, Anritsu 560-7N50B
- 10 dB Attenuator, Weinschel 1-10
- 30 dB Attenuator, Weinschel 1-30
- RF Reference Source, 0.050 GHz, Anritsu MA2418A
- DC Power Supply, Anritsu 2000-933



**Figure 5.** Power Monitor Verification

**b. Procedure**

1. Connect the DC power supply to the MA2418A Reference Source. (Refer to Figure 5.)
2. Connect the MA2418A Reference Source to the input of the 560-7N50B RF detector.
3. Connect the RF Detector output to the RF Detector input of the Site Master.
4. Connect the DC power supply to the appropriate line voltage to supply power to the MA2418A Reference Source.
5. Press and hold the **ESCAPE/CLEAR** key, then press the **ON/OFF** key to turn on the Site Master. (This sets the instrument to the factory preset state.)
6. Press the **MODE** key.
7. Use the Up/Down Arrow key to highlight **POWER MONITOR**, then press **ENTER**.
8. Press the **ZERO** soft key to zero the power monitor.  
When complete, **ZERO ADJ:ON** is displayed in the message area.
9. Verify that the power monitor reading is 0.0 dBm  $\pm$ 1 dB.
10. Connect the output of the MA2418A Reference Source to the two attenuators so as to add 40 dB of attenuation (Figure 5).
11. Connect the MA2418A Reference Source and the attenuators to the input of the 560-7N50B RF detector.
12. Verify that the power monitor reading is now -40.0 dBm  $\pm$ 2 dB.

**8. BIAS T (OPTION 10A) VERIFICATION**

**a. Equipment Required:**

- AC-DC Adapter Power Supply 40-115
- Open/Short, Anritsu 22N50
- 100 Ohm, 1 Watt load (100 Ohm, 1 Watt resistor soldered from the center pin to ground of an N-type connector.)

**b. Procedure:**

1. Connect the AC-DC Adapter Power Supply to the battery charging port on the Site Master

(Option 10A only works with the AC-DC Adapter).

2. Apply AC power to the power supply.
3. Press and hold the **ESCAPE/CLEAR** key, then press the **ON/OFF** key to turn on the Site Master. (This sets the instrument to the factory preset state.)
4. Press the **SYS** key.
5. Press the **OPTIONS** soft key.
6. Press the **BIAS-T** soft key to activate the Bias Tee option.
7. Verify that the display shows **15.0V, 0 mA**.
8. Connect the 22NF50 short to the RF In test port.
9. Verify the test port voltage relay clicks on and off, and **FAULT** is shown in the upper left corner of the display.
10. Remove the short and install the 100 Ohm load.

**CAUTION**

The 100 Ohm resistor will get hot. Verify the readings and remove the 100 Ohm load immediately.

11. Verify that the display shows **BIAS**, with a reading of 14.8 to 15.3 Volts, and 120 to 160 milliamps.

**9. BIAS T (OPTION 10B) VERIFICATION**

**a. Equipment Required:**

- Open/Short, Anritsu 22N50
- 100 Ohm, 1 Watt load (100 Ohm, 1 watt resistor soldered from the center pin to ground of a N-type connector)
- Anritsu T2904

**b. Procedure:**

1. Ensure the battery is fully charged. (Option 10B only works with the battery).
2. Press and hold the **ESCAPE/CLEAR** key, then press the **ON/OFF** key to turn on the Site Master. (This sets the instrument to the factory preset state.)
3. Press the **SYS** key.
4. Press the **OPTIONS** soft key.

5. Press the **BIAS-T** soft key to activate the Bias Tee option.

**NOTE**

When the Bias Tee option is selected, the unit is automatically forced into single sweep mode.

6. Press the **ON/OFF** soft key.
7. Verify that 15.1V, 0 mA is shown in the upper left corner of the display.
8. Connect the 22N50 SHORT to the RF In test port.
9. Press the **RUN/HOLD** key.

**NOTE**

The message “Powering up TMA...” will be displayed whenever the **RUN/HOLD** key is pressed.

10. Verify the test port voltage relay clicks on and off, and **FAULT** is shown in the upper left corner of the display.
11. Remove the 22N50.
12. Select **LOW VOLTAGE (12V)** and **LOW CURRENT (460 mA(↑), 244 mA(-))** by pressing the **LOW/HIGH VOLTAGE** soft key.
13. Connect the 100 Ohm load to the RF In test port.
14. Press the **RUN/HOLD** key and verify the reading displayed in upper left corner is approximately 11.9V to 12.9V, 120 mA to 160 mA.
15. Remove the 100 Ohm load.
16. Select **HIGH VOLTAGE (15V)** and **HIGH CURRENT (1A(↑), 650 mA(-))** by pressing the **LOW/HIGH VOLTAGE** and **LOW/HIGH CURRENT** soft keys.
17. Connect the T2904 to the RF In test port.
18. Press the **RUN/HOLD** key and verify the reading displayed in upper left corner is approximately 14.8V to 15.3V, 343 mA to 379 mA.

## 10. TERMINATION VERIFICATION

This test verifies the accuracy of the Site Master SM/PL termination using the precision return loss mode of the 541XXA Scalar Measurement System. Measurements of terminations using this mode provide results that are traceable to the NIST (National Institute of Standards and Technology) standards for the precision airline.

### a. Equipment Required:

- Scalar Measurement System, Anritsu 541XXA
- Offset SWR Autotester, Anritsu 560-97A50-20
- Precision Airline, Anritsu 18N50
- Open/Short, Anritsu 22N50
- 50 Ohm Termination, Anritsu 26N50
- Source Adapter, Anritsu 34NN50A

### b. Procedure

1. Connect the test equipment as shown in Figure 6.
2. Press the **Power** key on the 541XXA to On.
3. Press the **System Menu** key.
4. Using the Menu up-down keys: Highlight **RESET**, then press the **Select** key.
5. At the **RESET MENU** display, use the Menu up-down keys to highlight **RESET TO FACTORY DEFAULTS**, then press the **Select** key.
6. Set the signal source for the frequency range as follows:
  - (a) Press the **Frequency** key.
  - (b) Using the Data Entry Keypad or Data Entry Knob, set the Start frequency to 0.01 GHz. Press the **Enter** key.
  - (c) Using the Data Entry Keypad or Data Entry Knob, set the Stop frequency to 4.0 GHz. Press the **Enter** key.
7. Press the Channel 2 Display On/Off key to Off.
8. Press the Channel 1 Menu key.
9. Using the Menu up-down keys: Highlight **PRECISION RL**, then press the **Select** key.

10. At the PRECISION RETURN LOSS menu display, use the Menu up-down keys to highlight **FINAL**, then press the **Select** key.
11. Press the **Calibration** key.
12. At the CALIBRATION menu display, use the Menu up-down keys to highlight **START CAL**, then press the **Select** key.
13. At the PRECISION RETURN LOSS CALIBRATION menu display prompt, connect the Offset SWR Autotester to Input A, if you have not done so yet.
14. Connect the precision air line to the Offset SWR Autotester test port. Position the air line pointing vertically upward. Downward or horizontal positions make connector pin alignment difficult.

**NOTE**

Ensure that the beadless end of the precision airline is at the measurement connection point.

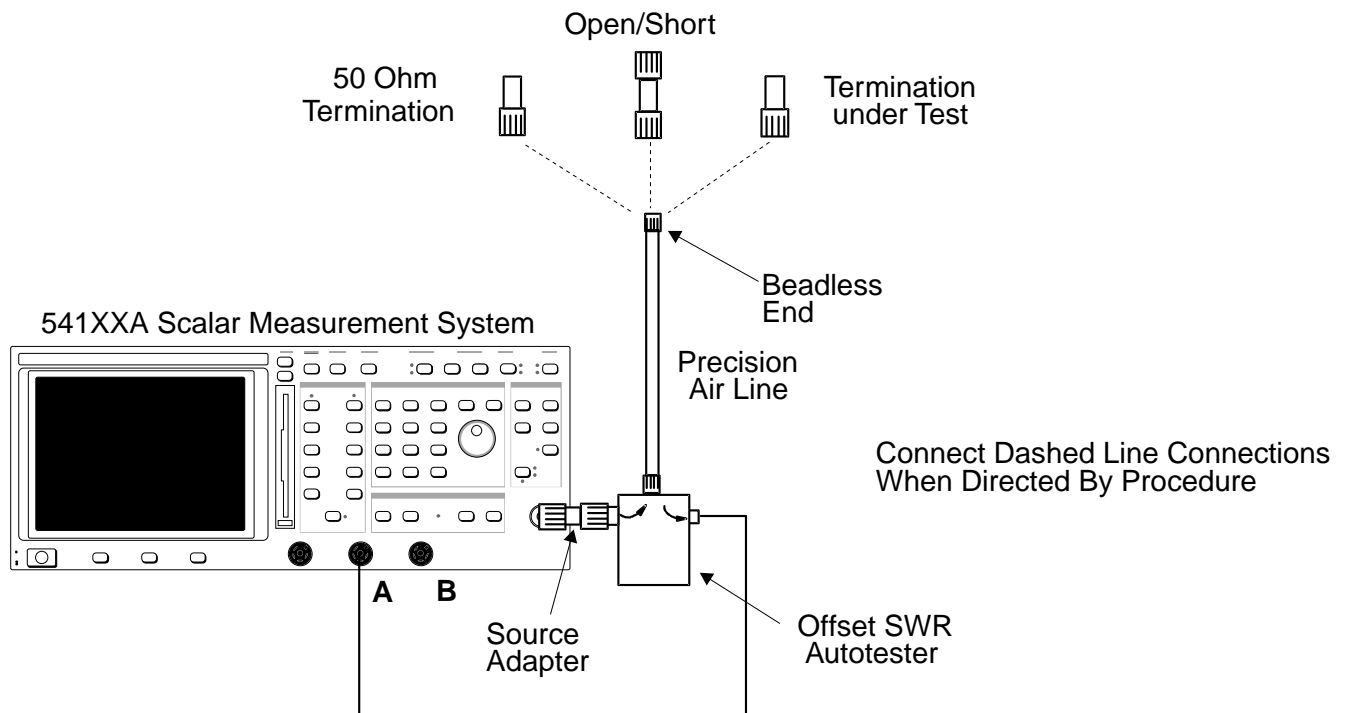
15. Press the **Select** key when ready.

16. At the PRECISION RETURN LOSS CALIBRATION menu prompt, connect the Open to the beadless end of the airline. Press the **Select** key to start the calibration.
17. Verify that the display resembles that shown in Figure 8.

**CAUTION**

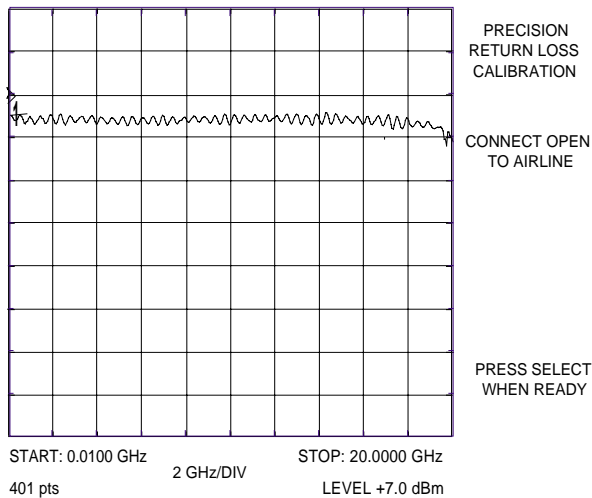
During both calibration and measurement, be sure to properly align the beadless connector of the airline. When the connectors are mis-aligned, a spike will usually be visible on the display.

18. At the next menu prompt, remove the Open and connect the Short to the beadless end of the airline. Press the **Select** key to start the calibration process.
19. At the next menu prompt, remove the Short and connect the 50 Ohm Termination to the beadless end of the air line. Press the **Select** key to start the calibration process.
20. When the calibration is complete, remove the 50 Ohm Termination.



**Figure 6.** 541XXA Precision Return Loss Setup

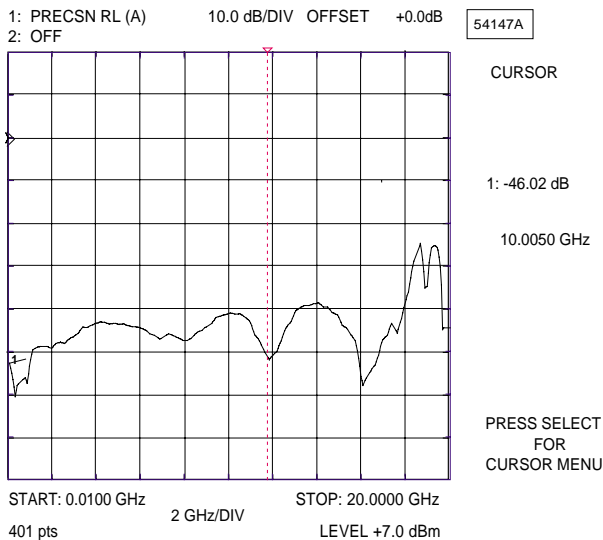
1: PRECSN RL (A) 10.0 dB/DIV OFFSET +0.0dB 54147A  
2: OFF



**Figure 7.** Example of a Good Connection

21. Connect the SM/PL termination to the beadless end of the air line and press the Select key to begin the measurement.

22. Observe that the waveform displayed resembles that shown in Figure 7.



**Figure 8.** Direct Readout of the Precision Return Loss

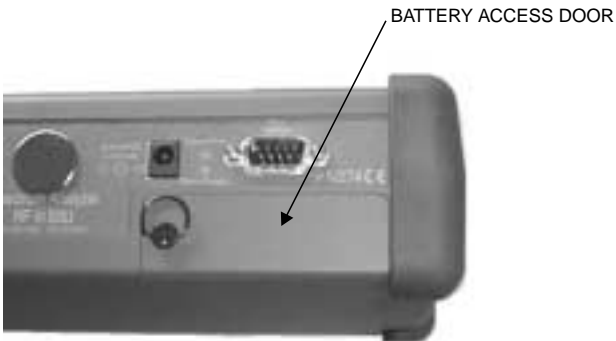
23. Press the **Cursor On/Off** key to On.
24. Observe the **Cursor** menu readout. The minimum return loss reading for the SM/PL termination should be 42 dB.



## 11. BATTERY PACK REMOVAL AND REPLACEMENT

This procedure provides instructions for removing and replacing the Site Master battery pack.

1. With the Site Master standing upright on a stable surface, locate the battery access door (Figure 9).



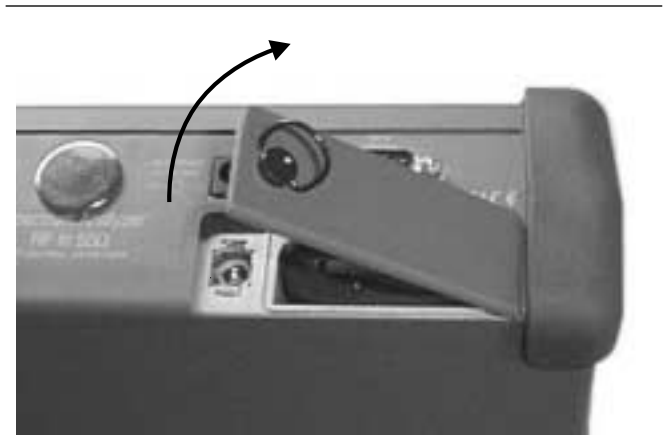
**Figure 9.** Battery Access Door Location

2. Lift up the access door handle and rotate it 90 degrees counterclockwise, as illustrated in Figure 10.

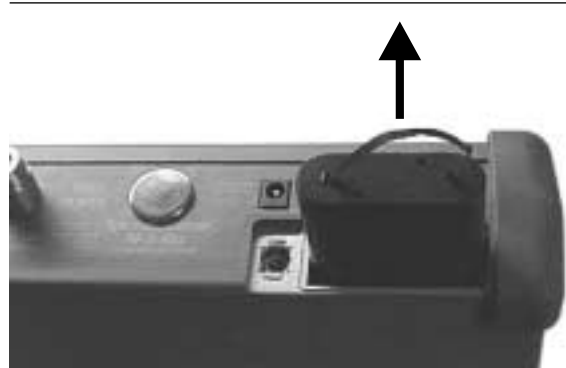


**Figure 10.** Rotate the Battery Access Door Handle

3. Lift the door and remove, as illustrated in Figure 11.
4. Grasp the battery lanyard and pull the battery straight up and out of the unit, as illustrated in Figure 12.



**Figure 11.** Removing the Battery Access Door



**Figure 12.** Removing the Battery

5. Replacement is the opposite of removal. Note the orientation of the battery contacts, and be sure to insert the new battery with the contacts facing the rear of the unit (Figure 13).



**Figure 13.** Battery Orientation

## 12. BATTERY INFORMATION

The following information relates to the care and handling of the Site Master battery, and NiMH batteries in general.

---



---

**Figure 14.** Site Master Battery

- The Nickel Metal Hydride (NiMH) battery supplied with the Site Master is shipped in a discharged state. Before using the Site Master, the internal battery must first be charged for three hours, either in the Site Master or in the optional battery charger (Anritsu part number: 2000-1029).
  - Use only Anritsu approved battery packs.
  - Recharge the battery only in the Site Master or in an Anritsu approved charger.
  - With a new NiMH battery, full performance is achieved after three to five complete charge and discharge cycles.
  - When the Site Master or the charger is not in use, disconnect it from the power source.
  - Do not charge batteries for longer than 24 hours; overcharging may shorten battery life.
  - If left unused a fully charged battery will discharge itself over time.
  - Temperature extremes will affect the ability of the battery to charge: allow the battery to cool down or warm up as necessary before use or charging.
  - Discharge an NiMH battery from time to time to improve battery performance and battery life.
  - The battery can be charged and discharged hundreds of times, but it will eventually wear out.
- The battery may need to be replaced when the operating time between charging becomes noticeably shorter than normal.
  - Never use a damaged or worn out charger or battery.
  - Storing the battery in extreme hot or cold places will reduce the capacity and lifetime of the battery.
  - Never short-circuit the battery terminals.
  - Do not drop, mutilate or attempt to disassemble the battery.
  - Do not dispose of batteries in a fire!
  - Batteries must be recycled or disposed of properly. Do not place batteries in household garbage.
  - Always use the battery for its intended purpose only.

### 13. FRONT PANEL ASSEMBLY REMOVAL AND REPLACEMENT

This procedure provides instructions for removing and replacing the Site Master front panel assembly. With the front panel assembly removed, the LCD display, keypad PCB, keypad membrane, and main PCB assemblies can be removed and replaced.

1. Place the Site Master face up on a work surface.
2. Remove the four rubber corner bumpers by carefully sliding the bumpers off of the case corners (Figure 15).



**Figure 15.** Removing the Corner Bumpers

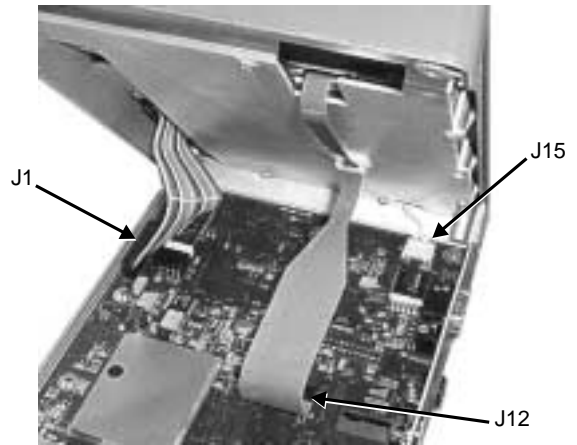
3. With the bumpers removed, the access holes for the case screws are revealed. Use a Phillips screwdriver to remove the four screws securing the two halves of the Site Master case together.
4. Carefully lift up on the right side (as viewed from the front) of the front half of the case and begin to separate the two halves.

#### **CAUTION**

Do not force or pull the two halves of the case apart as there are delicate cables attached between the two halves that must be disconnected first.

5. Carefully depress the latch tab and disconnect the LCD display cable from J12 on the main PCB.
6. Carefully disconnect the keypad interface cable from J1 on the main PCB.

7. Carefully disconnect the LCD display backlight cable from J15 on the main PCB.



**Figure 16.** Site Master Front Panel Cable Connections

8. Remove the front panel assembly.
9. Reverse the above steps to replace the front panel assembly.

#### **NOTE**

The corner bumpers only mount one way. That is, the raised area inside one end of the bumper (Figure 17) is made to conform to the contour of the front cover only.

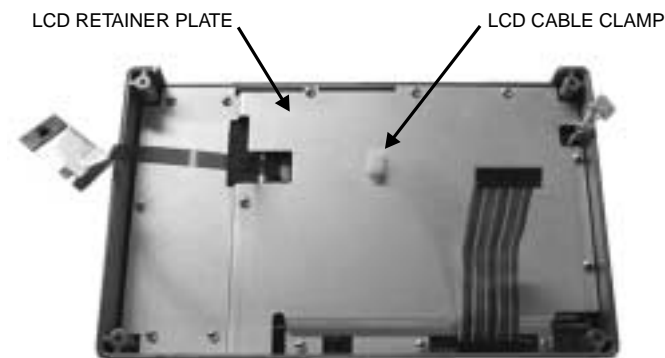


**Figure 17.** Corner Bumper Detail

## 14. LCD ASSEMBLY REPLACEMENT

This procedure provides instructions for removing and replacing the Liquid Crystal Display (LCD) once the front panel assembly has been separated from the Site Master.

1. Remove the front panel assembly as directed in section 13.
2. Place the front panel assembly face down on a protected work surface.
3. Remove the 14 Phillips screws that attach the LCD retainer plate to the front panel assembly.
4. Release the LCD display cable from the cable clamp on the LCD retainer plate.



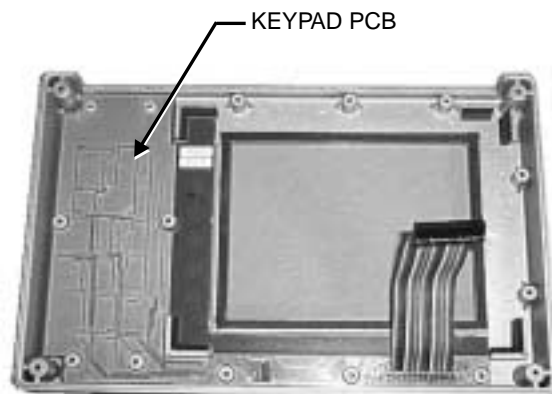
**Figure 18.** Front Panel Backing Plate

5. Remove the LCD retainer plate, carefully feeding the LCD cable through the access hole to avoid damage to the cable or connector.
6. Remove the rubber cushion pad from the LCD assembly and remove the assembly.
7. Reverse the above steps to install the replacement assembly.

## 15. KEY PAD PCB REPLACEMENT

This procedure provides instructions for removing and replacing the key pad PCB.

1. Remove the front panel assembly as directed in section 13.
2. Place the front panel assembly face down on a protected work surface.
3. Remove the 14 Phillips screws that attach the backing plate to the front panel assembly.
4. Release the LCD display cable from the retaining clip on the front panel backing plate (Figure 19).
5. Remove the front panel backing plate, carefully feeding the LCD cable through the access hole to avoid damage to the cable or connector.
6. Remove the rubber cushion pad from the key pad PCB and remove the PCB.



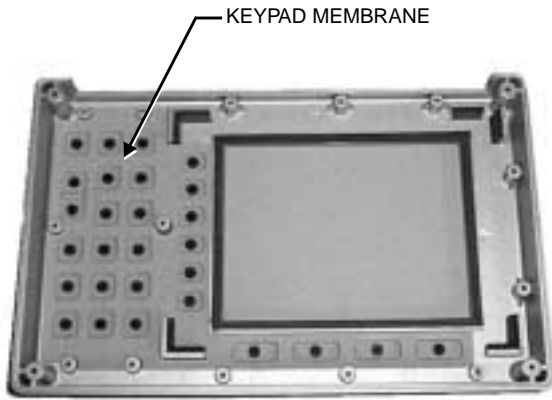
**Figure 19.** Front Panel Keypad PCB Location

7. Reverse the above steps to install the replacement assembly.

## 16. KEY PAD MEMBRANE REPLACEMENT

This procedure provides instructions for replacing the key pad membrane.

1. Remove the front panel assembly as directed in section 13.
2. Remove the key pad PCB as directed in section 15.
3. Remove the keypad membrane by gently pulling the membrane up and out of the holes in the front panel.



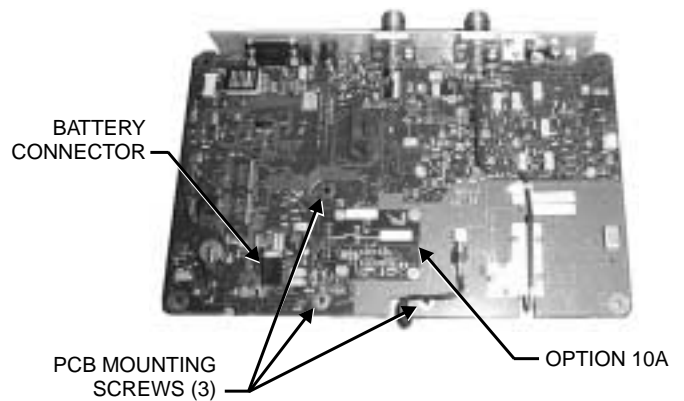
**Figure 20.** Front Panel Keypad Membrane

4. Reverse the above steps to install the replacement membrane.

## 17. MAIN PCB ASSEMBLY REPLACEMENT

This procedure provides instructions for replacing the main PCB assembly with the connector panel attached.

1. Remove the front panel assembly as directed in section 13.
2. Disconnect the battery connector from J13 on the main PCB.
3. Remove the three PCB mounting screws and remove the PCB assembly with the connector panel attached.



**Figure 21.** Main PCB

4. If Option 10A is installed (Figure 21) remove the option PCB by gently squeezing the standoff mounts to release the option PCB and disconnect it from the main board. Remove the standoffs and install them on the new main PCB, then install the Option 10A PCB on the new main PCB.
5. Reverse the above steps to install the new main PCB.

### **NOTE**

The main PCB connector panel fits into grooves in the two halves of the Site Master case. Make sure the panel is correctly aligned with the grooves before reassembling the two halves together.

## 18. REPLACEABLE PARTS

Replaceable parts for the Site Master Model S251C are listed below.

**Table 1.** Replaceable Parts List

Part Number	Description	Qty
<b>Accessories</b>		
10580-00065	User's Guide, Site Master S251C	1
10580-00066	Programming Manual, Site Master S251C (available on disk only)	1
2300-347	Software Tools, Site Master	1
40-115	Power Supply	1
2000-1029	Battery Charger	
22N50	Precision Short/Open, N Male	1
SM/PL	Connector, RF Termination	1
806-62	Cable Assy, Cig Plug, Female	1
800-441	Serial Interface Cable Assembly	1
48258	Soft Carrying Case	1
<b>Replaceable Parts</b>		
510-87	N-Connector	2
ND57371	Opt. 05 Input Connector w/cable	1
15-102	Liquid Crystal Display Assy	1
633-27	Rechargeable Battery, NiMH	1
ND57372	Main PCB Assembly, S251C	1
ND57373	Main PCB Assembly, S251C with Option 05	1
ND57374	Main PCB Assembly, S251C with Option 10A	1
ND57375	Main PCB Assembly, S251C with Option 05 and Option 10A	
ND60688	Main PCB Assembly, S251C with Option 10B	
ND60690	Main PCB Assembly, S251C with Option 05 and Option 10B	
52737-3	Keypad PCB Assembly	1
46649-1	Membrane Keypad, Main	1

Part Number	Description	Qty
<b>Hardware</b>		
900-160	Pan Head Screw, 4-40, 0.875	4
900-861	Pan Head Screw, 4-20, 0.365	15
900-869	Screw, 4-40, 0.875	4
900-720	Screw, 4-40, 0.187	3
900-754	Pan Head Screw, 4-40, 0.750	4
900-697	Screw, 4-40, 0.312	3
785-929	M-F Stand off, 4-40, 11/16	3
900-326	Kep Nut, 4-40, 0.187	8
790-516	Hole Plug, 0.6875L	1
790-42	Hole Plug, 0.625	1
761-79	Cap Vinyl, Black, round	1
<b>Case Parts</b>		
46652-1	Top Case only	1
46653-1	Bottom Case only	1
48231-1	Battery Door	1
790-509 790-510 790-511	Battery Door Latch (3 pieces)	1
46655	Case Corner Bumpers	4
46662	LCD Retainer Plate	1
48241	Foam, LCD Corners	8
48278	Foam, LCD Window	1
46659	Foam, LCD Backing	1
46661	Foam, Keypad Backing	1
48246	Foam, Battery Door	1
48271	Foam, Battery Compartment	1
720-19	Cable Clamp	1
790-515	Spring, Battery Compartment	1
55217	ID Label, Model S251C	1

**Table 2.** Anritsu Service Centers

---

**UNITED STATES**

ANRITSU COMPANY  
490 Jarvis Drive  
Morgan Hill, CA 95037-2809  
Telephone: (408) 776-8300  
FAX: 408-776-1744

ANRITSU COMPANY  
10 NewMaple Ave., Suite 305  
Pine Brook, NJ 07058  
Telephone: 973-227-8999  
FAX: 973-575-0092

ANRITSU COMPANY  
1155 E. Collins Blvd  
Richardson, TX 75081  
Telephone: 1-800-ANRITSU  
FAX: 972-671-1877

**AUSTRALIA**

ANRITSU PTY. LTD.  
Unit 3, 170 Foster Road  
Mt Waverley, VIC 3149  
Australia  
Telephone: 03-9558-8177  
FAX: 03-9558-8255

**BRAZIL**

ANRITSU ELECTRONICA LTDA.  
Praia de Botafogo 440. Sala 2401  
CEP22250-040, Rio de Janeiro, RJ, Brasil  
Telephone: 021-527-6922  
FAX: 021-53-71-456

**CANADA**

ANRITSU INSTRUMENTS LTD.  
700 Silver Seven Road, Suite 120  
Kanata, Ontario K2V 1C3  
Telephone: (613) 591-2003  
FAX: (613) 591-1006

**CHINA (SHANGHAI)**

ANRITSU ELECTRONICS CO LTD  
2F, Rm. B, 52 Section Factory Bldg.  
NO 516 Fu Te Road (N)  
Waigaoqiao Free Trade Zone  
Pudong, Shanghai 200131  
PR CHINA  
Telephone: 86-21-58680226  
FAX: 86-21-58680588

**FRANCE**

ANRITSU S.A  
9 Avenue du Quebec  
Zone de Courtaboeuf  
91951 Les Ulis Cedex  
Telephone: 016-09-21-550  
FAX: 016-44-61-065

**GERMANY**

ANRITSU GmbH  
Grafenberger Allee 54-56  
D-40237 Dusseldorf  
Germany  
Telephone: 0211-968550  
FAX: 0211-9685555

**INDIA**

MEERA AGENCIES (P) LTD  
23 Community Centre  
Zamroodpur, Kailash Colony Extension  
New Delhi, India 110 048  
Telephone: 011-644-2700  
FAX: 011-644-2500

**ISRAEL**

TECH-CENT, LTD  
4 Raul Valenberg St.  
Tel-Aviv, Israel 69719  
Telephone: 972-36-478563  
FAX: 972-36-478334

**ITALY**

ANRITSU Sp.A  
Rome Office  
Via E. Vittorini, 129  
00144 Roma EUR  
Telephone: (06) 50-2299-711  
FAX: 06-50-22-4252

**JAPAN**

ANRITSU CUSTOMER SERVICES LTD.  
1800 Onna Atsugi—shi  
Kanagawa-Prf. 243 Japan  
Telephone: 0462-96-6688  
FAX: 0462-25-8379

**KOREA**

ANRITSU SERVICE CENTER  
8F Hyunjuk-Bldg, 832-41  
Yeoksam-Dong  
Kangnam-Gu  
Seoul, 135-080, Korea  
Telephone: 82-2-553-6603  
FAX: 82-2-553-6605

**SINGAPORE**

ANRITSU (SINGAPORE) PTE LTD  
10, Hoe Chiang Road  
#07-01/02  
Keppel Towers  
Singapore 089315  
Telephone: 65-282-2400  
FAX: 65-282-2533

**SOUTH AFRICA**

ETESCSA  
12 Surrey Square Office Park  
330 Surrey Avenue  
Ferndale, Randburt, 2194  
South Africa  
Telephone: 011-27-11-787-7200  
Fax: 011-27-11-787-0446

**SWEDEN**

ANRITSU AB  
Botvid Center  
Fittja Backe 13A  
145 84  
Stockholm, Sweden  
Telephone: (08) 534-707-00  
FAX: (08)534-707-30

**TAIWAN**

ANRITSU COMPANY  
7F, NO.316, Sec.1,  
Nei Hu Road  
Taipei, Taiwan, R.O.C.  
Telephone: 886-2-8751-2126  
FAX: 886-2-8751-1817

**UNITED KINGDOM**

ANRITSU LTD.  
200 Capability Green  
Luton, Bedfordshire  
LU1 3LU, England  
Telephone: 015-82-43-3200  
FAX: 015-82-73-1303

---

**Anritsu**  
Discover What's Possible®